

SPIRAL DOUGH MIXERS

FOR BAKERY OPERATIONS

LARGE MODELS WITH FIXED BOWLS

Outstanding engineering and quiet operation make Univex M Series mixers an excellent choice for the large volume dough producer. Precision tolerances between the spiral arm, bowl and kneading column allow highly efficient blending of ingredients in short working times. Two speeds are standard, but single-speed M130, M160 and M200 models are also available for pizza and bagel production.

Choose manual, semi-automatic or automatic operation using the simple controls. Electronic timers can be set for both speeds. Automatic shifting into second speed frees up operator time. Rotation of the bowl can also be set to reverse during the automatic cycle. For unloading, the convenient pulse feature turns the bowl incrementally with the guard up. Electrical interlocks prevent accidental mixer operation.

The powerful belt drive provides low-vibration, low-noise performance and economical maintenance, for years of reliable service. And, despite their weight, M Series mixers are easy to move and position, thanks to built-in casters and leveling feet.

Comparable models are available equipped with power tilting lifts for both table and divider heights. Contact Factory for information.



- Up to 550 lbs. dough capacity – up to 330 lbs. flour capacity!
- Heavy-duty engineering – handles tough doughs
- Automatic, semi-automatic or manual mode
- Electronic timers automatically shift from 1st to 2nd speed
- Low maintenance costs
- Integral bowl safety guard
- Bi-directional bowl rotation
- Bowl pulse
- Moves easily on casters
- Models available with tilt lifts for table or divider height

WARRANTY

Univex M Series Spiral Dough Mixers carry a one-year, on-site parts and labor warranty against any flaws in materials and workmanship. This period begins with the date of purchase and, provided the unit is used properly in accordance with our instructions, is in full effect for one year from that date. Any work to be performed under this warranty must be performed between the hours of 8:00 a.m. and 5:00 p.m. local time, Monday through Friday. Univex will not pay overtime charges for work performed other than during normal business hours. Damages incurred in transit or from installation error, accident, alteration or misuse are not covered. Transit damages should be reported to the carrier immediately. Univex shall not be liable for any consequential, compensatory, incidental, or special damages. Contact Univex Service Department for any warranty claims.

SPIRAL DOUGH MIXERS

FOR BAKERY OPERATIONS

M130, M160, M200, M250

LARGE MODELS WITH FIXED BOWLS

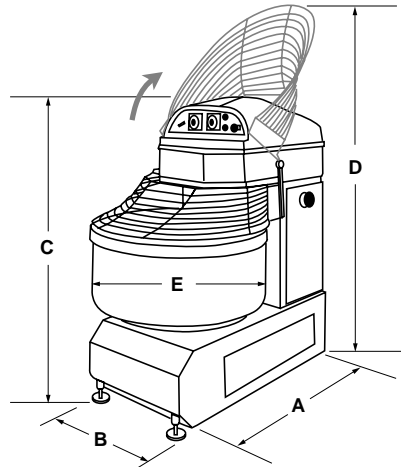

M130, M160, M200, M250

	M130	M160	M200	M250
A DEPTH	52" (132 cm)	58" (147 cm)	58" (147 cm)	62" (157 cm)
B WIDTH	32 3/4" (83 cm)	36 3/4" (93 cm)	36 3/4" (93 cm)	41" (104 cm)
C HEIGHT	55 1/2" (141 cm)	63" (160 cm)	63" (160 cm)	63" (160 cm)
D OPEN HEIGHT	74 1/2" (189 cm)	84 3/4" (215 cm)	84 3/4" (215 cm)	87" (221 cm)
E BOWL DIA.	31 1/2" (80 cm)	36 3/4" (93 cm)	36 3/4" (93 cm)	39 1/2" (100 cm)
NET WEIGHT	1213 lbs. (550 kg)	1874 lbs. (850 kg)	1918 lbs. (870 kg)	1984 lbs. (900 kg)
SHIPPING WEIGHT	1345 lbs. (610 kg)	2051 lbs. (930 kg)	2095 lbs. (950 kg)	2161 lbs. (980 kg)
CRATE depth	59" (150 cm)	65" (165 cm)	65" (165 cm)	69" (175 cm)
width	39 1/2" (100 cm)	43 1/2" (110 cm)	43 1/2" (110 cm)	47 1/4" (120 cm)
height	63" (160 cm)	71" (180 cm)	71" (180 cm)	71" (180 cm)
CUBIC MEASURE	85 ft ³ (2.4 m ³)	116 ft ³ (3.3 m ³)	116 ft ³ (3.3 m ³)	134 ft ³ (3.8 m ³)

SPECIFICATIONS

CAPACITIES	Model	M130	M160	M200	M250
Dough		285 lbs. (130 kg)	350 lbs. (160 kg)	440 lbs. (200 kg)	550 lbs. (250 kg)
Flour		175 lbs. (80 kg)	220 lbs. (100 kg)	275 lbs. (125 kg)	330 lbs. (150 kg)
Bowl		228 qts. (216 ltr)	288 qts. (273 ltr)	314 qts. (298 ltr)	388 qts. (368 ltr)
MOTORS					
Spiral Arm Motor					
Speeds* 1/2 (rpm)		100/200	100/200	100/200	100/200
HP		6.0/8.3	10.6/15.2	10.6/15.2	10.6/15.2
AMP Draw (208V)		22.4/26.5	38/44	38/44	38/44
AMP Draw (220V)		20.9/25.0	36/41.6	36/41.6	36/41.6
Bowl Motor (rpm)		15-16	15-16	15-16	15-16
HP		1.0	1.5	1.5	1.5
AMP Draw (208V)		6.3	8.6	8.6	8.6
AMP Draw (220V)		6.0	8.1	8.1	8.1

*M130, M160 and M200 are also available in single-speed models for bagel and pizza operations. Contact Factory for information.

ELECTRICAL	208/60/3-phase, 220/60/3-phase, or 460/60/3-phase. Low voltage electrical interlocks prevent mixer operation without bowl guard in place. No cord provided. Contact Factory for special voltages.
CONTROLS	Main Power switch. Momentary contact STOP and START buttons. Electronic timers for 1 st and 2 nd speeds. Bi-directional bowl rotation. Bowl pulse with guard raised.
DRIVE SYSTEM	Multi-belt spiral arm drive for quiet, low-vibration operation and low-cost maintenance.
CONSTRUCTION	Powder-coated steel body. Stainless steel bowl, spiral arm and bowl guard. Leveling feet, plus built-in casters for easy movement.
TILT LIFT OPTIONS	Consult Factory for information on models equipped with hydraulic powered tilting lifts, available in table and divider heights.



UNIVEX CORPORATION ■ 3 Old Rockingham Road ■ Salem, NH 03079-2140

Tel 603-893-6191 ■ Fax 603-893-1249 ■ E-mail univex@univexcorp.com

TOLL-FREE ORDERING FAX 1-800-356-5614

www.univexcorp.com

April 2002
Printed in USA