



Russell Hobbs®

Smart in the kitchen...



5-Speed Hand Mixer

Model RHHMRET

Instructions and Warranty

IMPORTANT SAFEGUARDS

When using electrical appliances, basic safety precautions should always be followed including the following:

1. Read all instructions.
2. To protect against risk of electrical shock do not put cord, plugs, or appliance in water or other liquid.
3. Close supervision is necessary when any appliance is used by or near children.
4. Unplug from outlet when not in use, before putting on or taking off parts, and before cleaning.
5. Avoid contacting moving parts.
6. Do not operate any appliance with a damaged cord or plug or after the appliance malfunctions, or is dropped or damaged in any manner. Contact Consumer Service for examination, repair or electrical or mechanical adjustment.
7. The use of attachments not recommended or sold by the manufacturer may cause fire, electric shock or injury.
8. Do not use outdoors.
9. Do not let cord hang over edge of table or counter.
10. Do not let cord contact hot surface, including the stove.
11. Keep hands, hair, clothing, as well as spatulas and other utensils away from Beaters and Dough Hooks during operation to reduce the risk of injury to persons, and/or damage to the mixer.
12. Remove Beaters and Dough Hooks from Hand Mixer before washing.

SAVE THESE INSTRUCTIONS

For household use only

Additional Important Safeguards

1. All users of this appliance must read and understand this Use and Care Guide before operating or cleaning this appliance.
2. The cord to this appliance should be plugged into a 120V AC electrical outlet only.
3. Do not leave this appliance unattended during use.
4. If this appliance begins to malfunction during use, immediately turn the unit OFF and unplug the cord. Do not use or attempt to repair the malfunctioning appliance.
5. If this appliance falls or accidentally becomes immersed in water, unplug it immediately. Do not reach into the water! Do not use this appliance after it has fallen into or becomes immersed in water.
6. To reduce the risk of injury to persons or property, never use this appliance in an unstable position.
7. Do not use this appliance for other than its intended use.

Polarized Plug

This appliance has a polarized plug (one blade is wider than the other). To reduce the risk of electric shock, this plug is intended to fit into a polarized outlet only one way. If the plug does not fit fully in the outlet, reverse the plug. If it still does not fit, contact a qualified electrician. Do not attempt to modify the plug in any way.

Electric Power

If the electrical circuit is overloaded with other appliances, your appliance may not operate properly. It should be operated on a separate electrical circuit from other appliances.

Getting to Know Your Russell Hobbs® 5-Speed Hand Mixer

Product may vary slightly from illustrations.

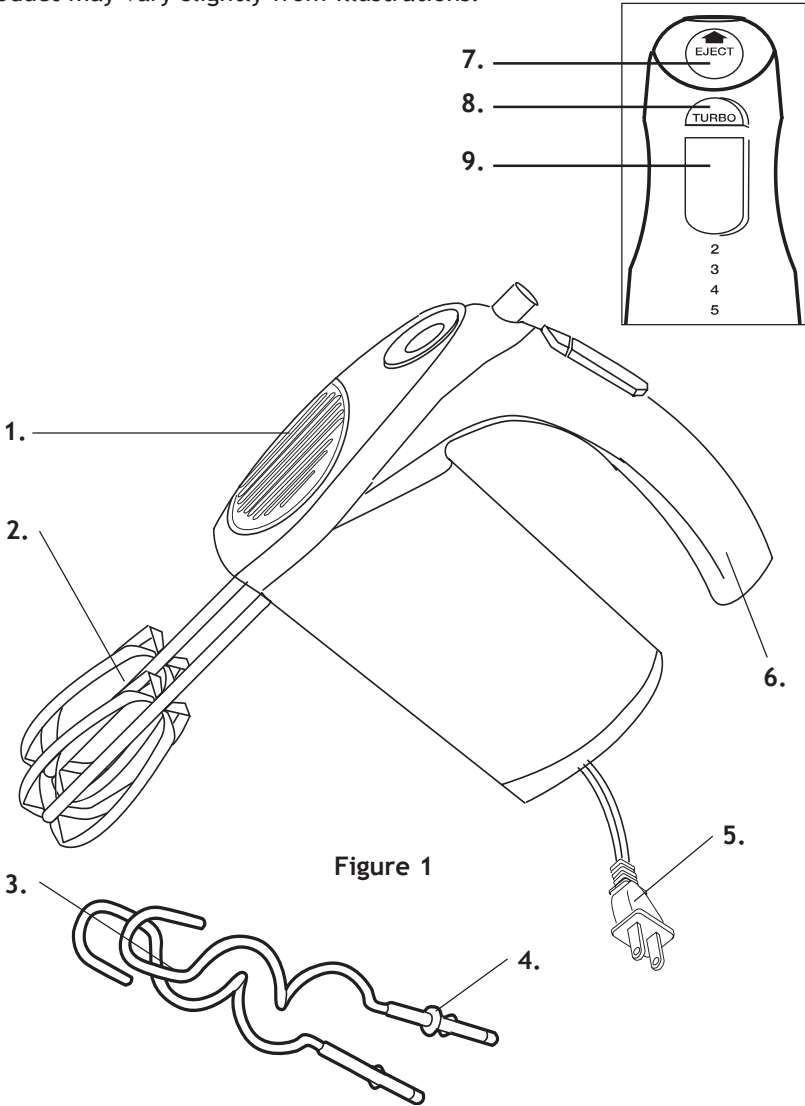

Figure 1

- | | |
|--|-----------------------------|
| 1. Motor Housing | 5. Cord with Polarized Plug |
| 2. Beaters (P/N 71228) | 6. Handle |
| 3. Dough Hooks
(P/N 71229 - without collar)
(P/N 71229C - with collar) | 7. Beater Eject Button |
| 4. Collar | 8. Turbo Button |
| | 9. Speed Control Lever |

Before Using for the First Time

Carefully unpack Hand Mixer. Wash Beaters and Dough Hooks in warm, soapy water. Rinse well and dry thoroughly. Wipe Motor Housing with a soft, clean cloth or sponge. Never immerse the Hand Mixer in water or any other liquid.

Using Your Hand Mixer

1. Make sure the Hand Mixer is unplugged.
2. Position the Speed Control Lever to "0," the OFF position.
3. Attach Beaters or Dough Hooks, following the instructions in the section named "Attaching Beaters" or "Attaching Dough Hooks."
4. Plug into 120V AC outlet.

CAUTION: Operating the Hand Mixer for more than 5 minutes at a time could cause the motor to overheat.

5. Place Beaters or Dough Hooks in container holding ingredients. Slide the Speed Control Lever to the desired Speed Setting, "1" being the lowest setting and "5" being the highest.
6. If you desire more speed on speed settings "1" through "5," press the Turbo Button to increase the speed for a short period of time.

CAUTION: To avoid overheating, do not use the Turbo Button for more than 1 minute at a time.

7. When you are finished mixing ingredients, position the Speed Control Lever to "0" and unplug Hand Mixer from the electrical outlet.

Turbo

Your Hand Mixer has 5 different speed settings. The Turbo feature can be used at any speed setting by depressing the Turbo Button. Resume previously selected speed by releasing Turbo Button.

NOTE: DO NOT use Turbo feature for more than 1 minute at a time as the Motor may overheat and damage the Hand Mixer.

Attaching Beaters

1. Make sure the Hand Mixer is unplugged and the Speed Control Lever is set to "0," the OFF position.
2. Align notches on Beaters with slots on the bottom of the Motor Housing, and push until they click and lock into place (see Figure 2).

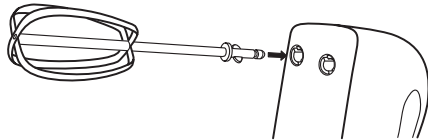

Figure 2

CAUTION: Always unplug Hand Mixer before installing or removing Beaters.

Attaching Dough Hooks

1. Make sure the Hand Mixer is unplugged and the Speed Control Lever is set to "0," the OFF position.
2. Insert the Dough Hook with the collar (see Figure 1) into the larger hole on the bottom of the Motor Housing. Align the notches on the Dough Hook with the slots on the bottom of the Motor Housing. Push until they click and lock into place (see Figure 2).
3. Insert the other Dough Hook into the smaller hole. Align the notches on the Dough Hook with the slots on the bottom of the Motor Housing. Push until they click and lock into place.

CAUTION: Always unplug Hand Mixer before installing or removing Dough Hooks.

Removing Beaters and Dough Hooks

1. Make sure Hand Mixer is unplugged.
2. Position the Speed Control Lever to "0," the OFF position.
3. Press firmly down on the Beater Eject Button to eject Beaters or Dough Hooks.

CAUTION: Always unplug Hand Mixer before installing or removing Beaters or Dough Hooks.

Mixing Guide

Use this Guide to help determine the proper Speed Control Setting for various mixing tasks.

Speed Control	Procedure
1	Best for mixing dry ingredients and folding in liquid ingredients, egg whites and whipped cream.
2	Ideal for creaming, stirring, making sauces, gravies, puddings and quick breads.
3	All purpose mixing.
	Preparing packaged cake mixes, creaming sugar & butter together.
4	Great for smooth batters.
5	Best for whipping cream, beating egg whites or mashing potatoes.

User Maintenance Instructions

This appliance requires little maintenance and contains no user serviceable parts. Do not try to repair it yourself. Any servicing requiring disassembly must be performed by a qualified appliance repair technician.

Care and Cleaning

CAUTION: Never immerse Motor Housing in water.

1. Make sure Hand Mixer is unplugged.
2. Eject Beaters or Dough Hooks from unit and wash them in warm, soapy water. Rinse well and dry thoroughly.
3. Wipe Motor Housing with a damp cloth or sponge.

Storage Instructions

Unplug Hand Mixer; store in its box or in a clean, dry place. Never store it while it is hot or still plugged in. Cord may be loosely wrapped around Motor Housing. Never wrap cord tightly around the appliance. Do not put any stress on the cord where it enters the unit, as it could cause the cord to fray and break.

LIMITED ONE-YEAR WARRANTY

Warranty Coverage: This product is warranted to be free from defects in materials or workmanship for a period of one (1) year from the original purchase date. This product warranty is extended only to the original consumer purchaser of the product and is not transferable. For a period of one (1) year from the date of original purchase of the product, our Repair Center will, at its option, either (1) repair the product or (2) replace the product with a reconditioned comparable model. These remedies are the purchaser's exclusive remedies under this warranty.

Warranty Service: To obtain warranty service, you must call our warranty service number at 1-800-233-9054 for return instructions on how to deliver the product, in either the original packaging or packaging affording an equal degree of protection to the Repair Center specified below. You must enclose a copy of your sales receipt or other proof of purchase to demonstrate eligibility for warranty coverage.

To return the appliance, ship to: To contact us, please write to, call, or email:

ATTN: Repair Center
708 South Missouri Street
Macon, MO 63552 USA

Consumer Relations Department
PO Box 7366
Columbia MO 65205-7366 USA
1-800-233-9054
E-mail: consumer_relations@toastmaster.com

What Is Not Covered: This warranty does not cover damage resulting from misuse, accident, commercial use, improper service or any other damage caused by anything other than defects in material or workmanship during ordinary consumer use. This warranty is invalid if the serial number has been altered or removed from the product. This warranty is valid only in the United States and Canada.

LIMITATION ON DAMAGES: THERE SHALL BE NO LIABILITY FOR ANY INCIDENTAL OR CONSEQUENTIAL DAMAGES FOR BREACH OF ANY EXPRESS OR IMPLIED WARRANTY OR CONDITION ON THIS PRODUCT.

DURATION OF IMPLIED WARRANTIES: EXCEPT TO THE EXTENT PROHIBITED BY APPLICABLE LAW, ALL IMPLIED WARRANTIES AND CONDITIONS, INCLUDING, WITHOUT LIMITATION, IMPLIED WARRANTIES AND CONDITIONS OF MERCHANTABILITY AND FITNESS FOR A PARTICULAR PURPOSE OR USE ON THIS PRODUCT ARE LIMITED IN DURATION TO THE DURATION OF THIS WARRANTY.

Some jurisdictions do not allow the exclusion or limitation of incidental or consequential damages, or allow limitations on how long an implied warranty lasts, so the above limitations or exclusions may not apply to you. This warranty gives you specific legal rights and you may have other rights under the laws of your jurisdiction.

For more information on our products, visit our website:
www.maxim-toastmaster.com.

©2006 All rights reserved.
Made in China