



Technical data sheet for

## BEAR VARIMIXER 100 LITRE ERGO

Model Number AE100VL-3

- Four set speeds and variable speed functionality
- Auto bowl lift function as standard
- Hardened glass touch screen control logic
- Controls centrally top mounted
- Ergonomic working heights for operators



### Overall Construction

- Heavy-duty steel fabricated body construction for durability and long life
- Machine body in two-pack paint finish
- Reinforced stainless steel mixing bowl
- Wire whisk reinforced for heavy work loads
- Spiral dough hook fully stainless steel
- Winged beater designed for improved aeration of all products

### Operation

- Two button bowl lift for safety of operator
- Auto lowering can be set after mixing completed
- Electronic timer 0 – 60 minutes
- Machine fitted with jog function
- Fitted with emergency stop as standard



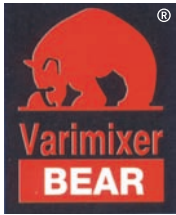

Technical data sheet for

# BEAR VARIMIXER 100 LITRE ERGO

Model Number AE100VL-3

## Machine Capacities (maximum)

- Egg white 14 litres (approx 420 whites)
- Whipped cream 20 litres
- Mayonnaise 38kg
- Mashed potato 60kg
- Cake/sponge Approx 60kg
- Dough 30kg (finished dough weight)

## Specifications

- W 730mm x D 1330mm x H 1960mm
- 400 – 415V, 3P+E 50Hz, 3kW, 4HP
- Weight 497kg

## Additional Technical Information

- Power outlet to be located a minimum 1.5m off floor

## Options

- 40 litre equipment and tools to suit (Consists of 40 litre bowl, whisk, beater, spiral dough hook)
- 60 litre equipment and tools to suit (Consists of 60 litre bowl, whisk, beater, spiral)

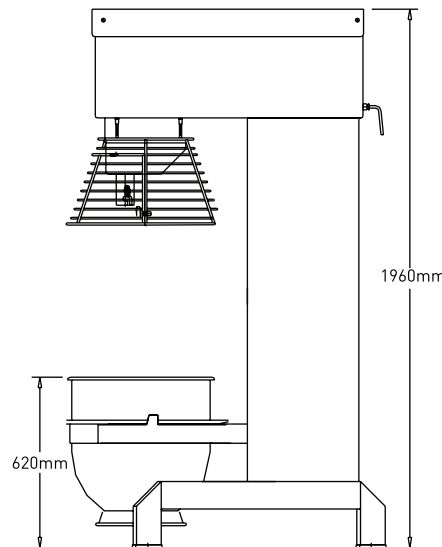
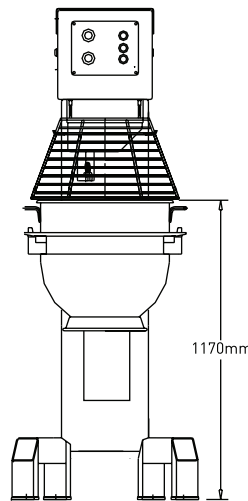
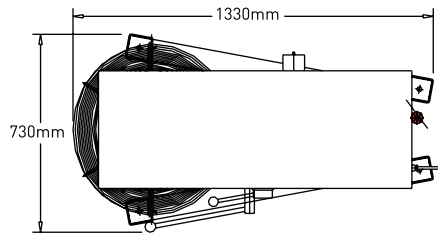

Australia  
Moffat Pty Limited

Victoria / Tasmania  
740 Springvale Rd  
Mulgrave  
Victoria 3170  
Australia  
Ph 03-9518 3888  
Fax 03-9518 3833  
Email [vsales@moffat.com.au](mailto:vsales@moffat.com.au)  
[www.moffat.com.au](http://www.moffat.com.au)

New South Wales  
Ph 02-8833 4111  
Email [nswsales@moffat.com.au](mailto:nswsales@moffat.com.au)  
[www.moffat.com.au](http://www.moffat.com.au)

South Australia  
Ph 03-9518 3888  
Email [vsales@moffat.com.au](mailto:vsales@moffat.com.au)  
[www.moffat.com.au](http://www.moffat.com.au)

Queensland  
Ph 07-3630 8600  
Email [qldsales@moffat.com.au](mailto:qldsales@moffat.com.au)  
[www.moffat.com.au](http://www.moffat.com.au)

Western Australia  
Ph 08-9202 6820  
Email [bgarcia@moffat.com.au](mailto:bgarcia@moffat.com.au)  
[www.moffat.com.au](http://www.moffat.com.au)

New Zealand  
Moffat Limited

Christchurch  
16 Osborne Street  
Christchurch 8011  
New Zealand  
Ph 03-389 1007  
Fax 03-389 1276  
Email [sales@moffat.co.nz](mailto:sales@moffat.co.nz)  
[www.moffat.co.nz](http://www.moffat.co.nz)

Auckland  
Ph 09-574 3150  
Email [sales@moffat.co.nz](mailto:sales@moffat.co.nz)  
[www.moffat.co.nz](http://www.moffat.co.nz)



In line with policy to continually develop and improve its products, Moffat Limited reserves the right to change specifications and design without notice.

Printed in China  
© Copyright Moffat Ltd  
Moffat/6244/BH/2.08

