

Item
Model
ProjectName



XBE20 Table Model

The XBE20 is an essential item in all kitchens where recipes are prepared using fresh ingredients: preparation of pastry bases, creams, mousses, various sauces or mixtures.

601854

FEATURES

- This planetary mixer can knead all types of doughs and pastries, mix semi-liquids, emulsions and various sauces.
- Stainless steel safety guard.
- Electronic speed variation provides flexibility in the regulations and very precise settings of the parameter.

- Touch button control panel improves the ergonomics and the reliability against the humidity or water jets.
- Control panel equipped with 0-59 minute timer.
- Choice of speeds.

Planetary mixers



DITO**Electrolux**

- A safety device automatically stops the machine when the bowl is lowered.
- Splash proof planetary system to avoid water from entering the mechanism.

- Removable safety guard for easy cleaning.
- Start/Stop button
- Height adjustable feet.
- Motor stops when bowl is raised.

Specifications

MODEL	XBEF20ST 601849	XBEF20AST 601854
Bowl Capacity lt	20	20
External dimensions - mm		
width	521	521
depth	685	685
height	980	980
Working capacity - kg of flour		
Choux pastry	3	3
Shortcrust pastry	5	5
Cold water paste	6	6
Sweet pastry	4	4
Croissant	5	5
Brioche	5	5
Meat kg	10	10
Puree - kg of potatoes	10	10
Power - kW		
installed-electric	0.9	0.9
Net weight - kg.	76	76
Supply voltage	200...240 V, 1N, 50/60	200...240 V, 1N, 50/60



DITO**Electrolux**

Included accessories

CODE	DESCRIPTION	XBEF20ST 601849	XBEF20AST 601854
653426	BOWL FOR 20LT MIXER	1	1
653114	DOUGH HOOK FOR 20LT MIXER	1	1
653116	PADDLE FOR 20LT MIXER	1	1
653109	WHISK FOR 20LT MIXER	1	1

Optional accessories

CODE	DESCRIPTION	XBEF20ST 601849	XBEF20AST 601854
653064	10L BOWL,HOOK,PADDLE,WHISK FOR 20L MIXER	✓	✓
653426	BOWL FOR 20LT MIXER	✓	✓
653114	DOUGH HOOK FOR 20LT MIXER	✓	✓
653016	MEATMINCER 70MM-H HUB-ENTERPR.CUT+3DISCS		✓
653116	PADDLE FOR 20LT MIXER	✓	✓
653226	PLANETARY MIXER 10L-H HUB-DISCONN.DRIVE		✓
653187	PUREE STRAINER FOR H HUB WITH 3 GRIDS		✓
653254	REINFORCED WHISK FOR 20LT MIXER	✓	✓
653435	S/S DISH SHELF FOR 20L/30L PLANET. MIXER	✓	✓
653434	S/S TABLE FOR 20LT PLANETARY MIXER	✓	✓
653062	SHARPENING GRINDSTONE FOR H HUB		✓
653225	VEGETAB.CUTTER H HUB+EJECTOR-DISCONNECT.		✓
653015	VEGETABLE CUTTER H HUB WITH EJECTOR		✓
653109	WHISK FOR 20LT MIXER	✓	✓



DITO

Electrolux

Installation drawings

601849, 601854

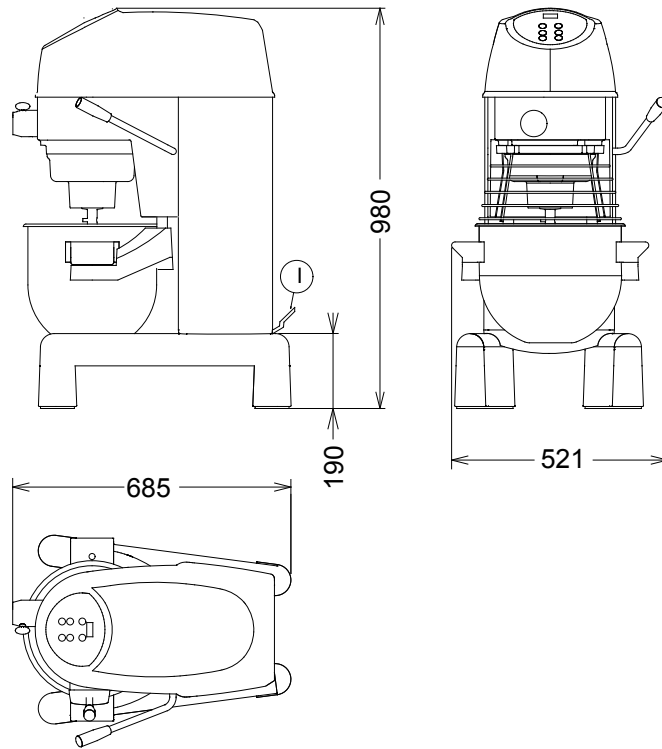

MODEL

XBEF20ST
601849

XBEF20AST
601854

I - Electrical connection

200...240 V, 1N, 50/60

200...240 V, 1N, 50/60

The manufacturer reserves the right to modify and make improvements to the products without giving prior warning. Dimensions, illustrations, technical data, weights, etc. are given as an indication only.



www.dito-electrolux.com

Planetary mixers

ADBE010

