

Item
Model
ProjectName



XBE10 with Hub

XBE10 satisfies all the preparation requirements of a professional kitchen, for kneading all types of dough and pastry, mixtures for pastries or meats and sauces and emulsions at high speeds (chantilly cream, beaten egg whites, etc.). The bowl is operated with the removable screen providing good ergonomics.

601998

FEATURES

- Stainless steel bowl.
- Three tools: stainless steel whisk, robust paddle and spiral hook.
- Transparent safety guard easily removable for cleaning.
- Electronic speed variation provides flexibility in the regulations and very precise settings of the parameter.
- Accessory drive hub for extra functions: vegetable cutter, puree strainer and meat mincer.
- Raising and lowering of the bowl is

operated with the raising of the safety guard.

- Touch button control panel improves the ergonomics and the reliability against the humidity or water jets.
- Control panel equipped with 0-59 minute timer.

Planetary mixers



DITO**Electrolux**

Specifications

MODEL	XBEF10AS 601998
Bowl Capacity lt	10
External dimensions - mm	
width	454
depth	606
height	700
Working capacity - kg of flour	
Choux pastry	2.5
Shortcrust pastry	3
Cold water paste	3.5
Sweet pastry	3
Croissant	3
Brioche	3
Meat kg	5
Puree - kg of potatoes	5
Power - kW	
installed-electric	0.75
total power	0.75
Net weight - kg.	38
Supply voltage	220...240 V, 1N, 50/60

Included accessories

CODE	DESCRIPTION	
653276	BOWL FOR 10LT MIXER	1
653268	DOUGH HOOK FOR 10LT MIXER	1
653267	PADDLE FOR 10LT MIXER	1
653269	WHISK FOR 10LT MIXER	1

Optional accessories

CODE	DESCRIPTION	
653276	BOWL FOR 10LT MIXER	✓
653268	DOUGH HOOK FOR 10LT MIXER	✓
653016	MEATMINCER 70MM-H HUB-ENTERPR.CUT+3DISCS	✓
653267	PADDLE FOR 10LT MIXER	✓
653187	PUREE STRAINER FOR H HUB WITH 3 GRIDS	✓
653225	VEGETAB.CUTTER H HUB+EJECTOR-DISCONNECT.	✓
653015	VEGETABLE CUTTER H HUB WITH EJECTOR	✓
653269	WHISK FOR 10LT MIXER	✓



DITO

Electrolux

Installation drawings

601998

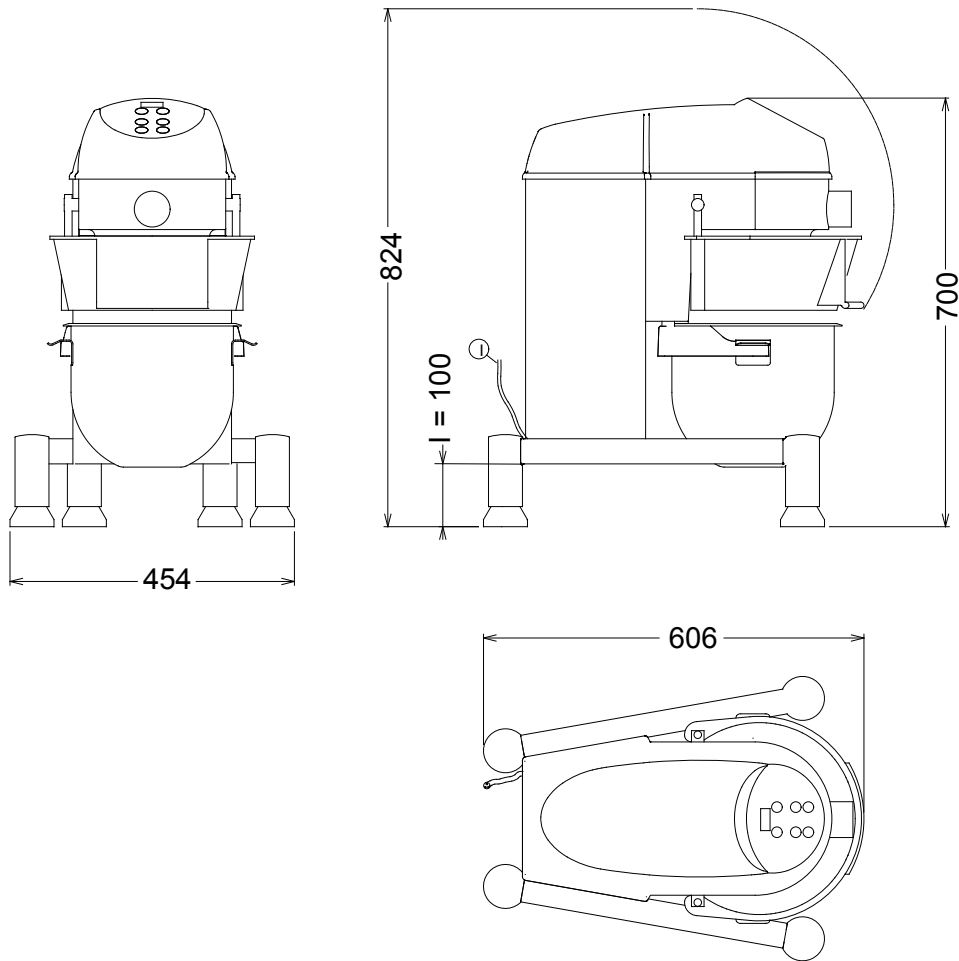

MODEL

I - Electrical connection

XBEF10AS
601998

220...240 V, 1N, 50/60



Planetary mixers

The manufacturer reserves the right to modify and make improvements to the products without giving prior warning. Dimensions, illustrations, technical data, weights, etc. are given as an indication only.



www.dito-electrolux.com



ADBC020