

Item
Model
ProjectName



601308

FEATURES

- 18/8 stainless steel 80 litre bowl.
- Stainless steel spiral kneading hook, designed to stop the pastry from rising up.

XBE80

The XBE80 is a high performance, powerful and sturdy 80 litre beater-mixer, with an exceptional range of speeds for optimum results. The XBE80 can knead a full bowl of flour and water paste, which is equivalent to around 40 kg of dough. With the XBE80 and its electronic speed variator, the professional user has a very wide range of speed, from very slow to ultra-quick.

- Cast aluminium (sheet) paddle.
- 18/8 stainless steel whisk (a heavy duty whisk is available as an option for heavier work).
- Geared reducer for the raising and lowering of bowl.

Planetary mixers



DITO**Electrolux**

- Protected bowl.
- Bowl trolley with bumpers and swivelling castors.

Specifications

MODEL	XBE80AS 601309	XBE80SX 601501	XBE80S 601308
External dimensions - mm			
width	685	685	685
depth	1050	1050	1050
height	1445	1445	1445
Working capacity - kg of flour			
Choux pastry	12.5	12.5	12.5
Shortcrust pastry	20	20	20
Cold water paste	25	25	25
Sweet pastry	20	20	20
Croissant	23	23	23
Brioche	23	23	23
Meat kg	38	38	38
Puree - kg of potatoes	38	38	38
Power - kW			
installed-electric	4	4	4
Net weight - kg.	310	305	305
Supply voltage	380...440 V, 3N, 50/60	380...440 V, 3N, 50/60	380...440 V, 3N, 50/60
Accessory Hub	✓		
Stainless steel		✓	



DITO**Electrolux**

Included accessories

CODE	DESCRIPTION	XBE80AS 601309	XBE80SX 601501	XBE80S 601308
653132	BOWL FOR 80LT MIXER	1	1	1
653585	BOWL TROLLEY-40/60/80LT PLANETARY MIXERS	1	1	1
653133	DOUGH HOOK FOR 80LT MIXER	1	1	1
653135	PADDLE FOR 80LT MIXER	1	1	1
653134	WHISK FOR 80LT MIXER	1	1	1

Optional accessories

CODE	DESCRIPTION	XBE80AS 601309	XBE80SX 601501	XBE80S 601308
653034	40L BOWL,HOOK,PADDLE,WHISK FOR 60L MIXER	✓	✓	✓
653085	60L BOWL,HOOK,PADDLE,WHISK FOR 80L MIXER	✓	✓	✓
653132	BOWL FOR 80LT MIXER	✓	✓	✓
653443	BOWL SCRAPER 80LT	✓	✓	✓
653585	BOWL TROLLEY-40/60/80LT PLANETARY MIXERS	✓	✓	✓
653133	DOUGH HOOK FOR 80LT MIXER	✓	✓	✓
653433	ELECTRIC HEATING FOR 60/80L PLANET.MIXER	✓	✓	✓
653482	HEAVY DUTY HOOK FOR 80LT PLANETARY MIXER	✓	✓	✓
653016	MEATMINCER 70MM-H HUB-ENTERPR.CUT+3DISCS	✓		
653135	PADDLE FOR 80LT MIXER	✓	✓	✓
653226	PLANETARY MIXER 10L-H HUB-DISCONN.DRIVE	✓		
653187	PUREE STRAINER FOR H HUB WITH 3 GRIDS	✓		
653232	S/S MEATMINCER 82MM-H HUB-ENTERPR+1 DISC	✓		
653062	SHARPENING GRINDSTONE FOR H HUB	✓		
653225	VEGETAB.CUTTER H HUB+EJECTOR-DISCONNECT.	✓		
653015	VEGETABLE CUTTER H HUB WITH EJECTOR	✓		
653134	WHISK FOR 80LT MIXER	✓	✓	✓



DITO**Electrolux**

Installation drawings

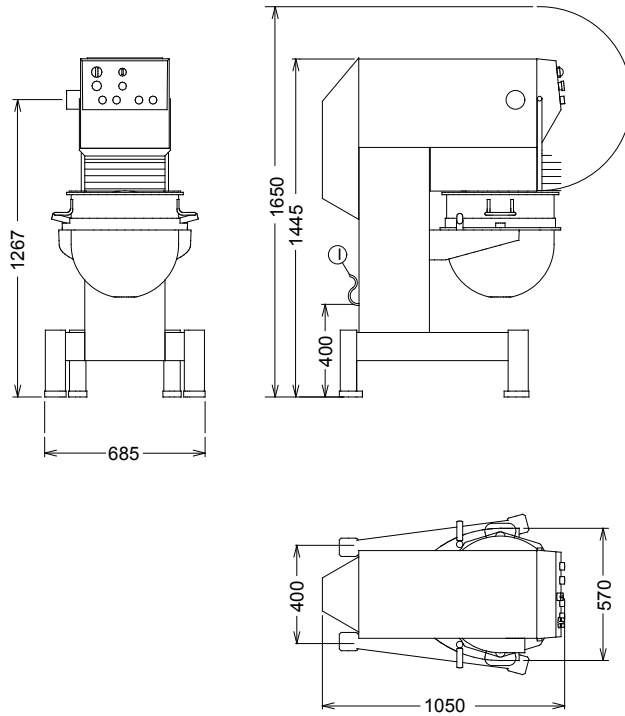
601309, 601308, 601501**MODEL**

I - Electrical connection

**XBE80AS
601309**380...440 V, 3N,
50/60**XBE80SX
601501**380...440 V, 3N,
50/60**XBE80S
601308**380...440 V, 3N,
50/60

The manufacturer reserves the right to modify and make improvements to the products without giving prior warning. Dimensions, illustrations, technical data, weights, etc. are given as an indication only.



www.dito-electrolux.com

Planetary mixers

ADBL010

