

**Electrolux**

**DITO**

**Planetary Mixer  
XEM-10 10.5 Qt. Counter Model**

ITEM # \_\_\_\_\_

MODEL # \_\_\_\_\_

PROJECT NAME # \_\_\_\_\_

SIS # \_\_\_\_\_

AIA # \_\_\_\_\_

**Electrolux**  
**DITO**



**Planetary Mixer  
XEM-10 10.5 Qt. Counter Model**

603388 (XEM10S) 10.5 Qt. Counter Model Planetary Mixer  
115 V/1p/60Hz

**Short Form Specification**

Item No. \_\_\_\_\_

Unit to be Electrolux-Dito 10.5 Qt. Planetary Mixer with features that include: stainless steel bowl. One-piece alloy head containing the self-lubricating planetary gears and the transmission. Powerful motor with mechanical speed variation with 10 speeds. A single lever is used to raise and lower the bowl. A safety device will automatically stop the machine when the bowl is lowered. Supplied with 3 tools: Beater, Dough Hook and Whisk.

**Main features**

- Power: 1 HP—single phase.
- Variable speed: 25-180 rpm.
- 750 watts.
- Red OFF, green ON buttons, and timer.
- Compact design.
- 10 speeds that permit exceptional results.
- The "V" belt speed variator protects the mechanism and the motor against incorrect use.
- Stainless steel bowl - 10 qt. capacities.
- Raising and lowering of the bowl controlled by lever with an automatic locking of the bowl when in the raised position.
- Safety device will automatically stop the machine when the bowl is lowered.
- Powerful motor with high start-up torque.
- Planetary gearing with self-lubricating gears eliminating any risk of leaks.
- Sturdy construction with mechanically welded strong metal frame.
- Delivered with:
  - Beater, Dough Hook, Wire Whisk and Mixing Bowl for 10.5 qt.
- Dimensions: (LxWxH): 23.5" x 18" x 27".
- Approx. shipping weight—128 lbs.
- ETL electrical and sanitation listed/CETL (Canada).
- NEMA # : 5-15P.
- 2 year parts warranty, 1 year labor.

**Accessories**

- Beater for 10.5 qt. Mixer
- Dough Hook for 10.5 qt. Mixer
- Wire Whisk for 10.5 qt. Mixer
- Mixing Bowl for 10.5 qt. Mixer

**Optional Accessories**

- Beater for 10.5 qt. Mixer (PNC 653267)
- Dough Hook for 10.5 qt. Mixer (PNC 653268)
- Wire Whisk for 10.5 qt. Mixer (PNC 653269)
- Mixing Bowl for 10.5 qt. Mixer (PNC 653276)



NEMA #: 5-15P

Approval: \_\_\_\_\_

**Electrolux Professional, Inc.**

[www.electroluxusa.com/professional](http://www.electroluxusa.com/professional)

3225 SW 42nd Street, Fort Lauderdale, Florida, 33312 • Telephone Number: 866-449-4200 • Fax Number: 954-327-6789

**Planetary Mixer  
XEM-10 10.5 Qt. Counter Model**

**Front View**

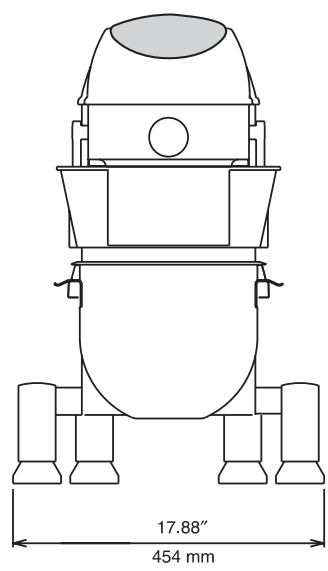

**Top View**

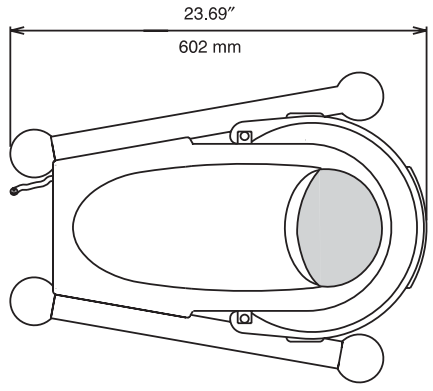

EC = Electrical connection  
EC = 3.94"

**Side View**

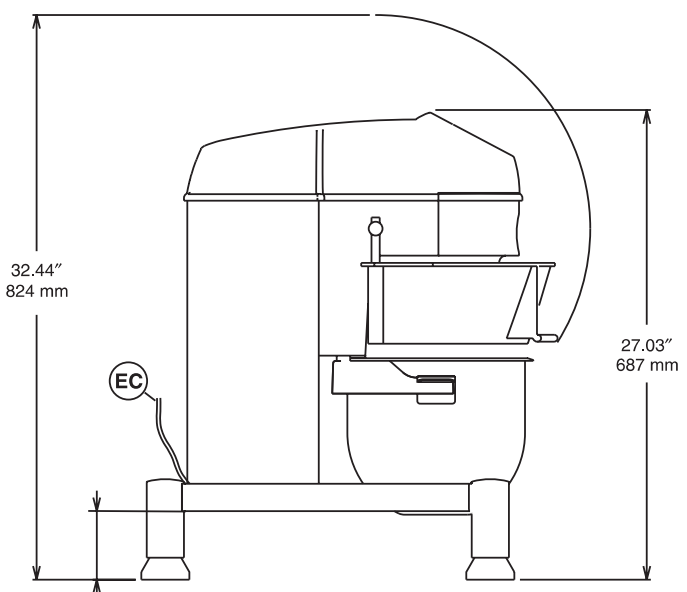

**Electric**

Supply voltage:  
603388 (XEM10S) 115 V/1p/60Hz - 8.6 A

**Key Information**

**Working capacity – lbs. of flour**

Shortcrust pastry:	6.5
Cold water paste:	7.5
Sweet pastry:	6.5
Croissant:	6.5
Brioche:	6.5
Meat:	11
Potato Puree:	11