

BUNN[®]

ULTRA-2

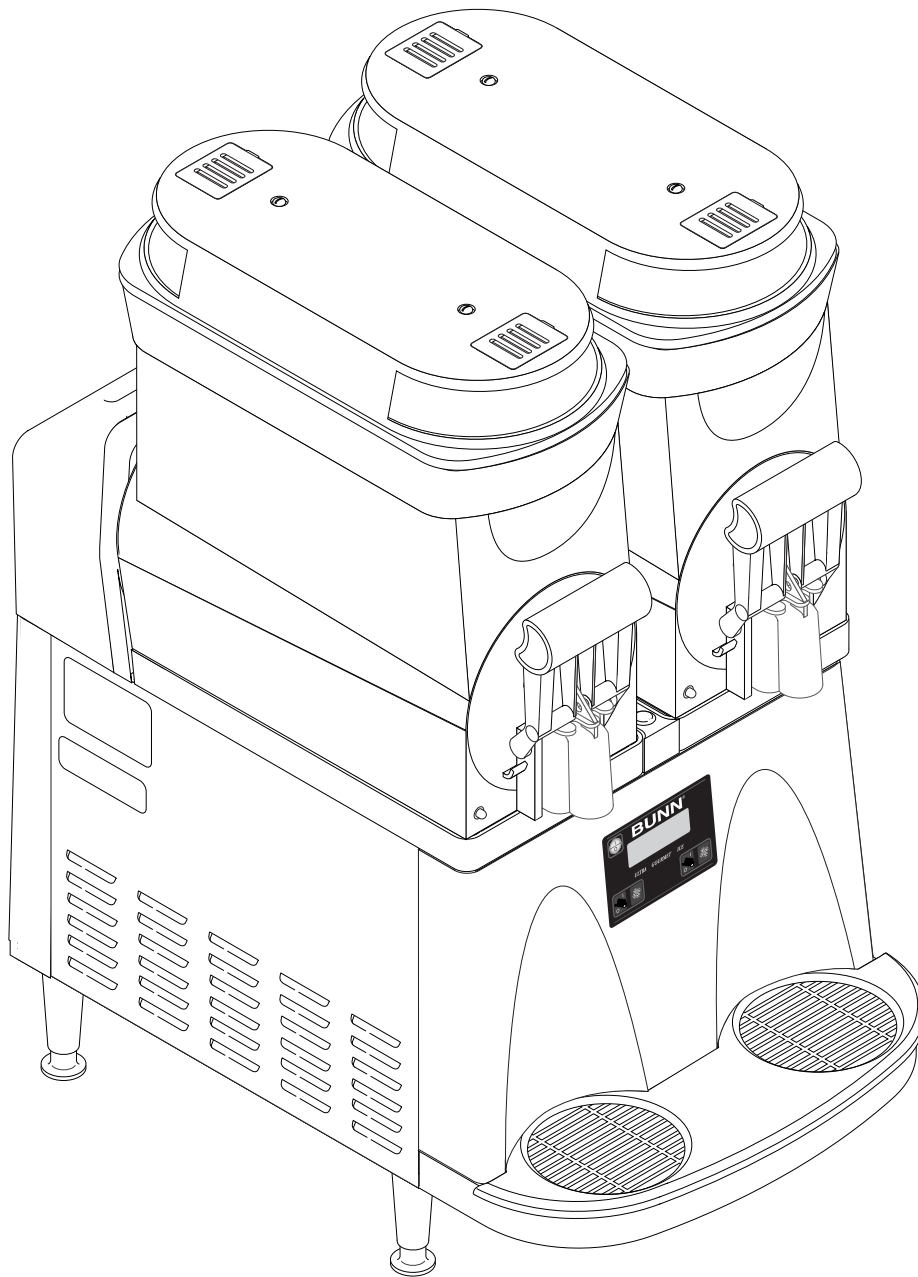

INSTALLATION & OPERATING MANUAL

BUNN-O-MATIC CORPORATION

POST OFFICE BOX 3227

SPRINGFIELD, ILLINOIS 62708-3227

PHONE: (217) 529-6601 FAX: (217) 529-6644

INTRODUCTION

This equipment dispenses granita-type and cold liquid drinks on demand from separate hoppers. Operating controls are accessible only through password protection.

CONTENTS

Introduction & Warranty	2
User Notices	3
Site Preparation, Electrical Requirements	3
Initial Setup	4
Operating Controls	6
Programming	7
Using the Dispenser for Granita-Type Products	24
Using the Dispenser for Cold Liquid Products	24
Other Recommendations For Your Dispenser	25
Recommended Daily Cleaning	26
Auto-fill Cleaning Instructions	28
Required Regular Maintenance	29
Schematic Wiring Diagrams	31

BUNN-O-MATIC COMMERCIAL PRODUCT WARRANTY

Bunn-O-Matic Corp. (“BUNN”) warrants equipment manufactured by it as follows:

- 1) All equipment other than as specified below: 2 years parts and 1 year labor.
- 2) Electronic circuit and/or control boards: parts and labor for 3 years.
- 3) Compressors on refrigeration equipment: 5 years parts and 1 year labor.
- 4) Grinding burrs on coffee grinding equipment to grind coffee to meet original factory screen sieve analysis: parts and labor for 3 years or 30,000 pounds of coffee, whichever comes first.

These warranty periods run from the date of installation BUNN warrants that the equipment manufactured by it will be commercially free of defects in material and workmanship existing at the time of manufacture and appearing within the applicable warranty period. This warranty does not apply to any equipment, component or part that was not manufactured by BUNN or that, in BUNN’s judgment, has been affected by misuse, neglect, alteration, improper installation or operation, improper maintenance or repair, damage or casualty. This warranty is conditioned on the Buyer 1) giving BUNN prompt notice of any claim to be made under this warranty by telephone at (217) 529-6601 or by writing to Post Office Box 3227, Springfield, Illinois 62708-3227; 2) if requested by BUNN, shipping the defective equipment prepaid to an authorized BUNN service location; and 3) receiving prior authorization from BUNN that the defective equipment is under warranty.

THE FOREGOING WARRANTY IS EXCLUSIVE AND IS IN LIEU OF ANY OTHER WARRANTY, WRITTEN OR ORAL, EXPRESS OR IMPLIED, INCLUDING, BUT NOT LIMITED TO, ANY IMPLIED WARRANTY OF EITHER MERCHANTABILITY OR FITNESS FOR A PARTICULAR PURPOSE. The agents, dealers or employees of BUNN are not authorized to make modifications to this warranty or to make additional warranties that are binding on BUNN. Accordingly, statements by such individuals, whether oral or written, do not constitute warranties and should not be relied upon.

If BUNN determines in its sole discretion that the equipment does not conform to the warranty, BUNN, at its exclusive option while the equipment is under warranty, shall either 1) provide at no charge replacement parts and/or labor (during the applicable parts and labor warranty periods specified above) to repair the defective components, provided that this repair is done by a BUNN Authorized Service Representative; or 2) shall replace the equipment or refund the purchase price for the equipment.

THE BUYER’S REMEDY AGAINST BUNN FOR THE BREACH OF ANY OBLIGATION ARISING OUT OF THE SALE OF THIS EQUIPMENT, WHETHER DERIVED FROM WARRANTY OR OTHERWISE, SHALL BE LIMITED, AT BUNN’S SOLE OPTION AS SPECIFIED HEREIN, TO REPAIR, REPLACEMENT OR REFUND.

In no event shall BUNN be liable for any other damage or loss, including, but not limited to, lost profits, lost sales, loss of use of equipment, claims of Buyer’s customers, cost of capital, cost of down time, cost of substitute equipment, facilities or services, or any other special, incidental or consequential damages.

USER NOTICES

Carefully read and follow all notices on the equipment and in this manual. They were written for your protection. All notices are to be kept in good condition. Replace any unreadable or damaged labels.

 WARNING	
<p>Moving Parts.</p> <p>Do not operate unit with this panel removed.</p>	<p>Risk Of Electrical Shock.</p> <p>Disconnect power before servicing unit.</p>

27442.0000

 CAUTION
<p>Risk of Electric Shock.</p> <p>This equipment may have two power supply cords. Unplug all cords before moving or servicing this equipment.</p>

29947.0000

<p>INTENDED FOR USE AT A ROOM TEMPERATURE OF 27°C (80°F)</p>

29979.0000

<p>CHARGE</p> <p>Type R404A, Amount 10 oz</p> <p>Design Pressures: High 240 Low 34</p>
--

32162.0000 (ULTRA-2)

<p>CHARGE</p> <p>Type R404A, Amount 9.5 oz(269g)</p> <p>Design Pressures: High 215 Low 40</p>

29373.0000 (ULTRA-2A)

 WARNING
<ul style="list-style-type: none"> • DO NOT OVERLOAD CIRCUIT. □ • ALWAYS ELECTRICALLY GROUND THE CHASSIS □ OR ADAPTOR PLUG. □ • DO NOT DEFORM PLUG OR CORD. □ • FOLLOW NATIONAL AND LOCAL ELECTRICAL CODES. □ • KEEP COMBUSTIBLES AWAY.
<p>FAILURE TO COMPLY RISKS EQUIPMENT □ DAMAGE, FIRE OR SHOCK HAZARD.</p>
<p>READ THE ENTIRE OPERATING MANUAL □ BEFORE USING THIS PRODUCT</p> <p><small>00986.0002E 5/98 ©1994 Bunn-O-Matic Corporation</small></p>

00986.0002

SITE PREPARATION

The dispenser is very heavy. Place it on a sturdy counter or shelf capable of supporting at least 180 lbs. It is for indoor use only.

The dispenser must have at least six inches of space behind it. This space is needed for airflow, air filter removal, and cleaning. A clearance of at approximately six inches is recommended between the dispenser sides and the wall or another appliance. The dispenser performs better if not placed near any heating appliance. Leave some space so the dispenser can be moved for cleaning.

ELECTRICAL REQUIREMENTS

CAUTION – Improper electrical installation will damage components. An electrician must provide electrical service as specified below.

Model ULTRA-2, This dispenser has an attached cordset and requires a 2-wire, grounded, individual branch circuit rated 120 volts ac, 15 amp, single phase, 60 Hz. The mating connector must be a NEMA 5-15R. *(Refer to the dataplate for exact electrical requirements.)*

Model ULTRA-2A, This dispenser has an attached cordset and requires a 2-wire, grounded, individual branch circuit rated 230 volts ac, 10 amp, single phase, 50 Hz. *(Refer to the dataplate for exact electrical requirements.)*

NOTE – Bunn-O-Matic does not recommend the use of any extension cord with these dispensers.

INITIAL SETUP

CAUTION – The dispenser is very heavy! Use care when lifting or moving it. Use at least two people to lift or move the dispenser.

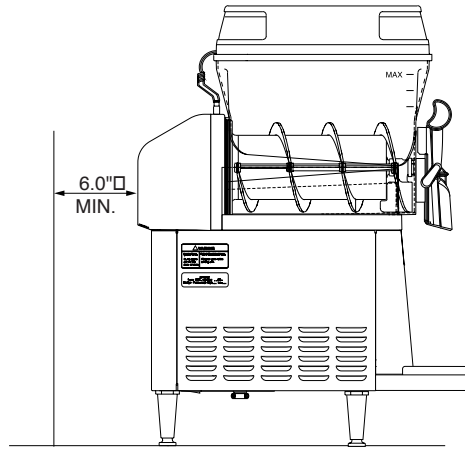

1. Set the dispenser on a sturdy counter top. The dispenser requires a minimum of 6.0" air clearance at the rear of the dispenser. For optimum performance, **do not** let warm air from surrounding machines blow on the ULTRA -2.

NOTE – The dispenser should be level or slightly lower in front for proper operation.

2. Remove all shipping material, including the compressor support eyebolt, the cooling drum supports, the "Do Not Lift Here" signs from the cooling drums, and the "Rinse Before Using" signs from each hopper. For models without PAF (Powder Auto-Fill™), proceed to step #7.

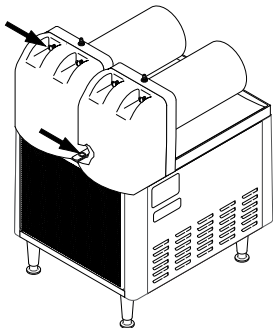

3. Remove the rear plastic plug from the trim strip between the hopper drip trays and loosen the auger motor cover screws.

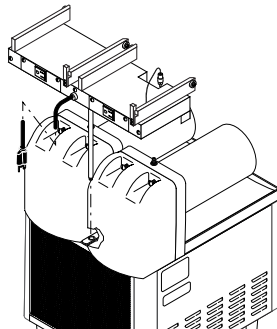

4. Place PAF platform assembly on top of the motor covers and install support rod into hole in trim strip.

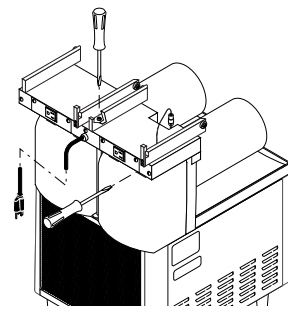

5. Tighten support rod from top of platform. Retighten motor cover screws.

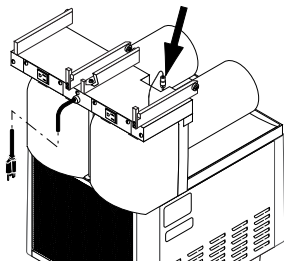

6. Plug RCA cord into ULTRA base unit. Proceed with steps 7 thru 12.

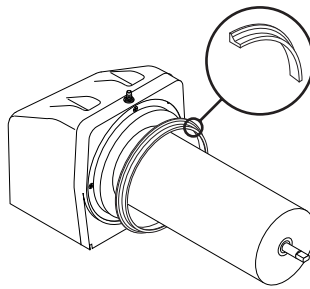

7. Install each hopper seal over the flange at the rear of the cooling drums as shown.

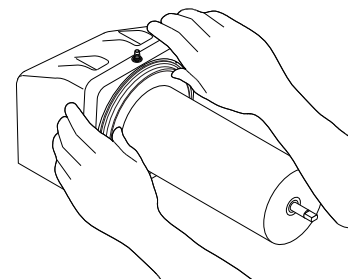

8. Press the seals firmly into place.

INITIAL SETUP (CONT.)

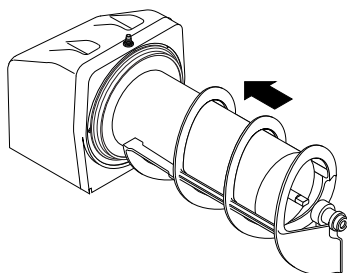

- 9.** Align the auger shaft with the flat fin of the auger. Push the augers as far as they will go and rotate them so the flat fin is facing up.

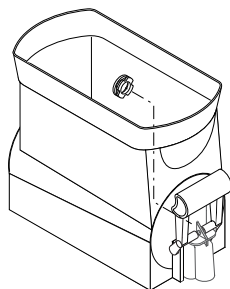

- 10.** Install auger nose bushing into inside front of hopper.

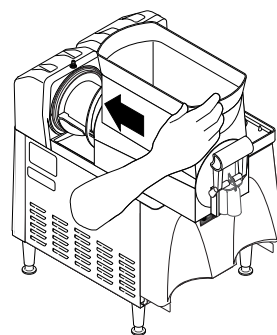

- 11.** Thoroughly rinse the hoppers and install them over the augers and cooling drums.

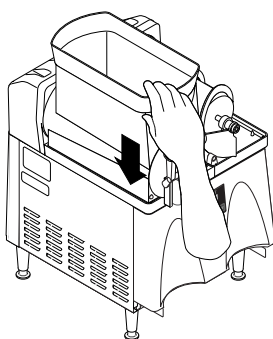

- 12.** Slide them into place and push them down until the hopper lock plungers snap into place. For models without PAF, proceed to step 15.

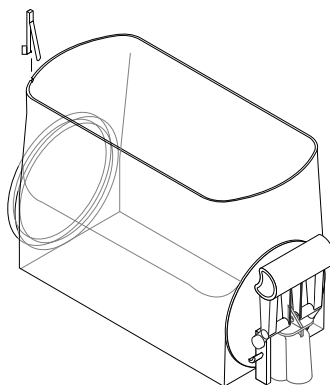

- 13.** For models with PAF, install level probes into slots at top rear of PAF hoppers.

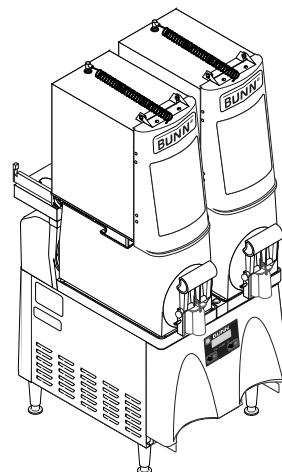

- 14.** Install PAF unit onto platform and plug power cord into rear of platform. Plug platform power cord into proper outlet. (Refer to PAF manual for water connections)(Proceed to step 17)

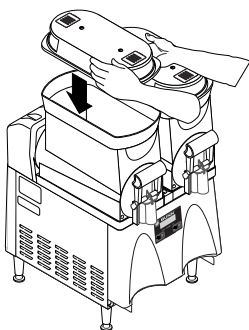

- 15.** Set the lids on the hoppers. Lift slightly and slide back or front for filling.

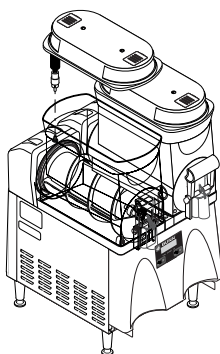

- 16.** Plug in the hopper lid lamp cords.

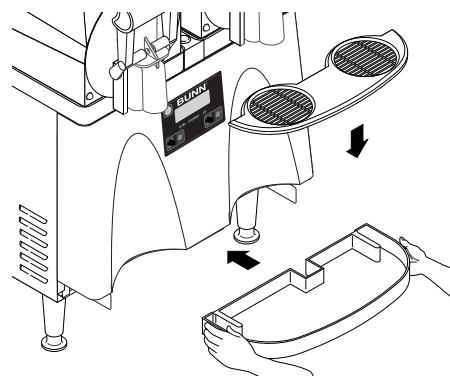

- 17.** Assemble the drip tray.

OPERATING CONTROLS

There are five of these switches that will be used for the operation of the dispenser.

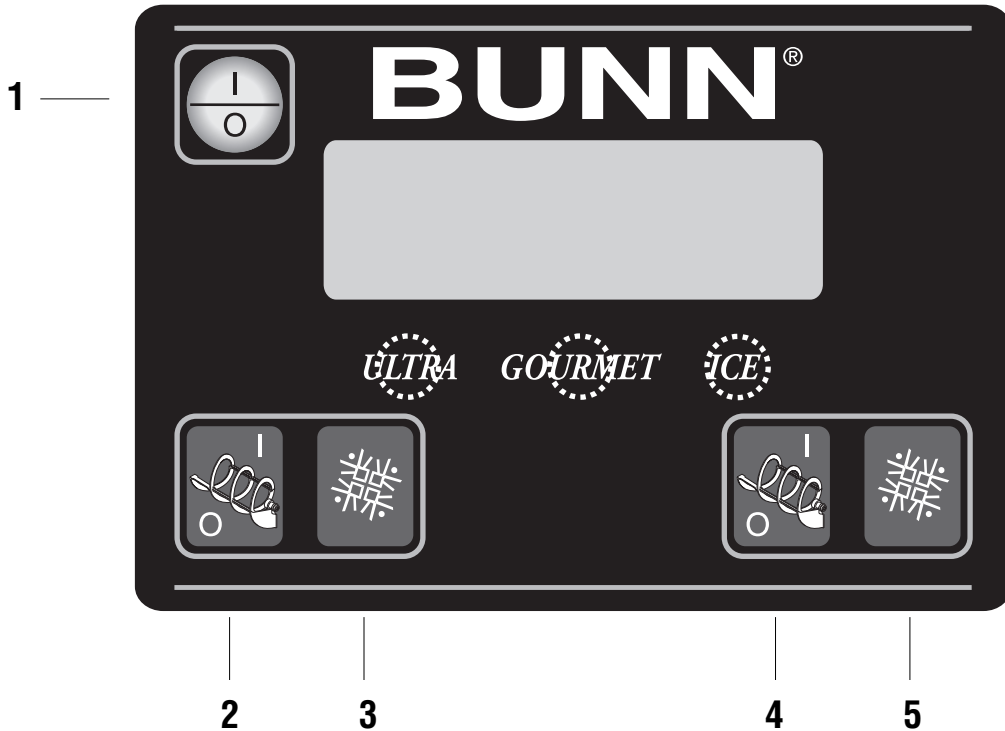

1.  switch (upper left corner of the control pad)

This switch is the ON/OFF toggle switch which powers up the dispenser and the LCD display. When ON the Date and Time toggle back and forth continuously except during programming.

2.  (bottom left corner)

This is used to turn the left side auger motor to AUGER ON, AUGER OFF or AUGER REFILL ON. (Refill only applicable when installed)

3.  (bottom left corner)

This is used to turn the left side ice control to OFF, ICE or CHILL.

4.  (bottom right corner)

This is used to turn the right side auger motor AUGER ON, AUGER OFF or AUGER REFILL ON. (Refill only applicable when installed)

5.  (bottom right corner)

This is used to turn the right side ice control to OFF, ICE or CHILL.

PROGRAMMING

Using the menu-driven display on the front of the dispenser, the operator has the ability to alter or modify various parameters such as beverage consistency and set day/night “ON/OFF” times. The operator is also prompted to check a variety of periodic service functions or even a step-by-step cleaning routine. There is also the opportunity to return all changes back to factory default settings.

Access to most controls can be password protected to allow only qualified personnel to make changes.

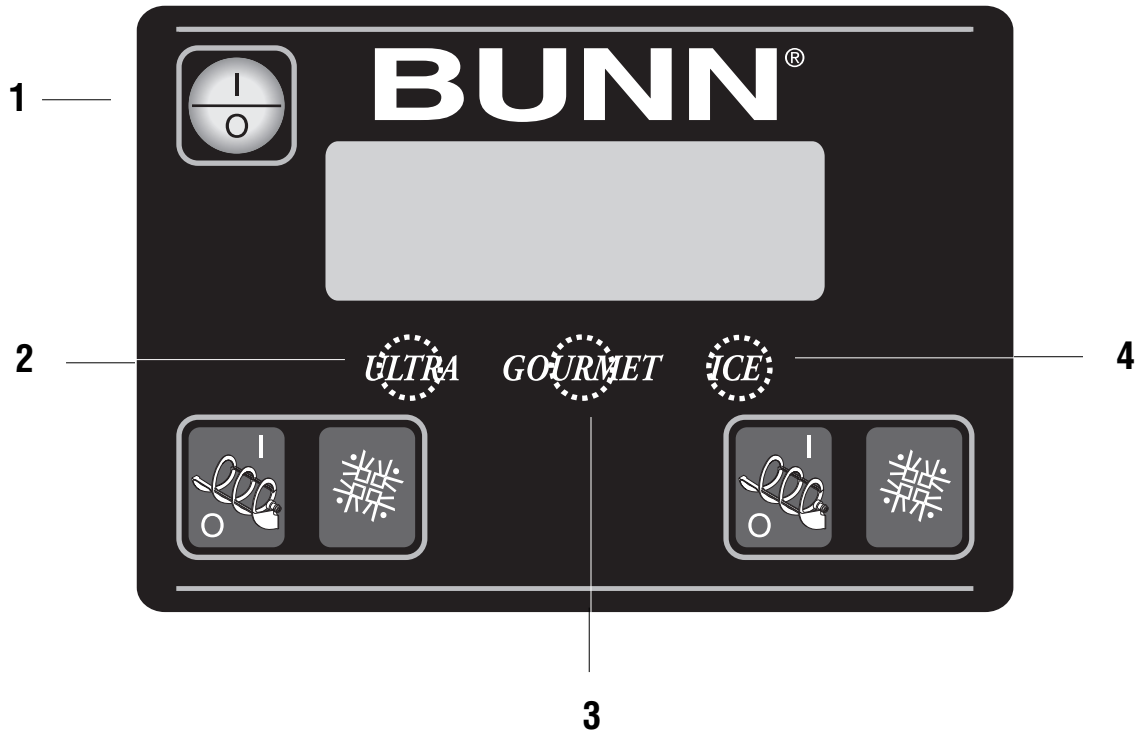

PROGRAMMING SWITCHES

To access the programming mode, and to scroll through the different function screens, hidden programming switches are used. There are three of these switches that will be used for the setup of the dispenser.

1. **I/O** switch (upper left corner of the control pad)

This switch is the ON/OFF toggle switch which powers up the dispenser and the LCD display. This switch is also used as back up switch in menu mode.

2. **“GOURMET”** (center under display)

Press and hold this switch 5 seconds to access the Menu Function Index. This switch is also used as “NEXT” to scroll through the functions.

3. **“ULTRA”** (left under display)

When prompted by a selection from the menu to answer yes or no, the “ULTRA” switch is used to answer “NO” or (-) minus.

4. **“ICE”** (right under display)

When prompted by a selection from the menu to answer yes or no, the “ICE” switch is used to answer “YES” or (+) plus.

PROGRAMMING THE DISPENSER

During normal operations, the Date, the Time, and the Serial Number toggle back and forth continuously. The following function screens are in the order they appear from the menu display. Each screen will have instructions and procedures to program the various functions of the dispenser.

HOME SCREEN

Displays the TIME, DATE, SERIAL NUMBER and ASSET NUMBER which toggle back and forth continuously.

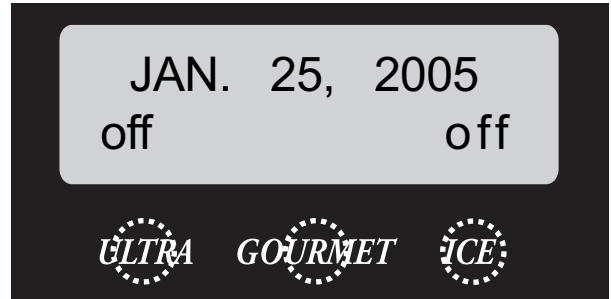
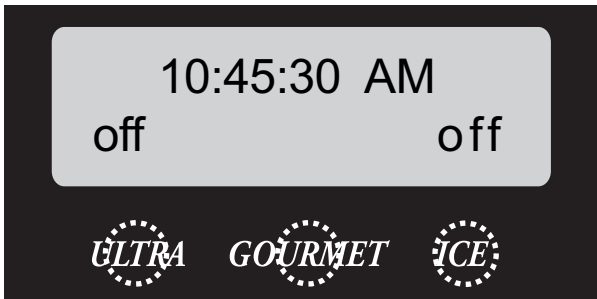

MENU FUNCTION INDEX

Press and hold for five seconds the GOURMET hidden switch to enter into the Menu Function Index. The screens on the following page are in order that they appear from the menu display. Pressing NO ("ULTRA") or NEXT ("GOURMET") will advance to the next function. Press ON/OFF ("I/O") will back up to the previous screen. A one minute time out will return to the Home Screen.

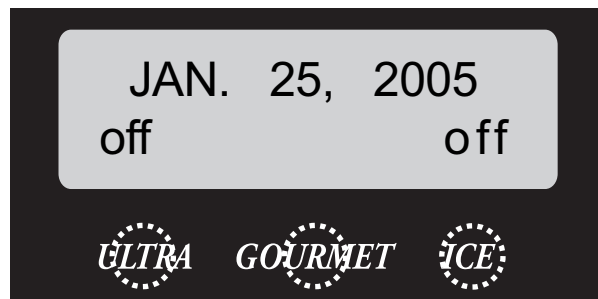

MENU FUNCTION INDEX (Continued)

CLEANING GUIDE ?
NO YES

ULTRA GOURMET ICE

SET THICKNESS ?
NO YES

ULTRA GOURMET ICE

TEST AUGERS ?
NO YES

ULTRA GOURMET ICE

SET DATE TIME ?
NO YES

ULTRA GOURMET ICE

PASSWORD 0
(-) NEXT (+)

ULTRA GOURMET ICE

SET LANGUAGE ?
NO YES

ULTRA GOURMET ICE

SET NIGHT TIME
(-) OFF (+)

ULTRA GOURMET ICE

DEFROST MINUTES
(-) OFF (+)

ULTRA GOURMET ICE

PM COMPLETE ?
NO YES

ULTRA GOURMET ICE

6 MONTH PM
(-) OFF (+)

ULTRA GOURMET ICE

DAY TO CLEAN OFF
(-) NEXT (+)

ULTRA GOURMET ICE

YES THICK ADJUST
(-) NEXT (+)

ULTRA GOURMET ICE

SWITCHES
(-) ON (+)

ULTRA GOURMET ICE

250 L REFILL 155
(-) THRESHOLD (+)

ULTRA GOURMET ICE

250 R REFILL 155
(-) THRESHOLD (+)

ULTRA GOURMET ICE

TEST REFILL ?
NO YES

ULTRA GOURMET ICE

AD MESSAGE
(-) DISABLED (+)

ULTRA GOURMET ICE

ENTER ASSET #
AN000000

ULTRA GOURMET ICE

SET PASS WR 0
(-) NEXT (+)

ULTRA GOURMET ICE

RESTORE DEFAULT?
NO YES

ULTRA GOURMET ICE

Cleaning Guide

This function leads the operator through a nine step cleaning process when answered YES (“ICE”). Depress GOURMET to display the next cleaning instruction.

When entering this mode, the refrigeration system will automatically turn OFF. After step when hoppers are drained, the augers will turn OFF. Three messages will display after advancing past the last cleaning instruction: FINISH/NEXT, PLEASE WAIT, ULTRA VERSION #__._.

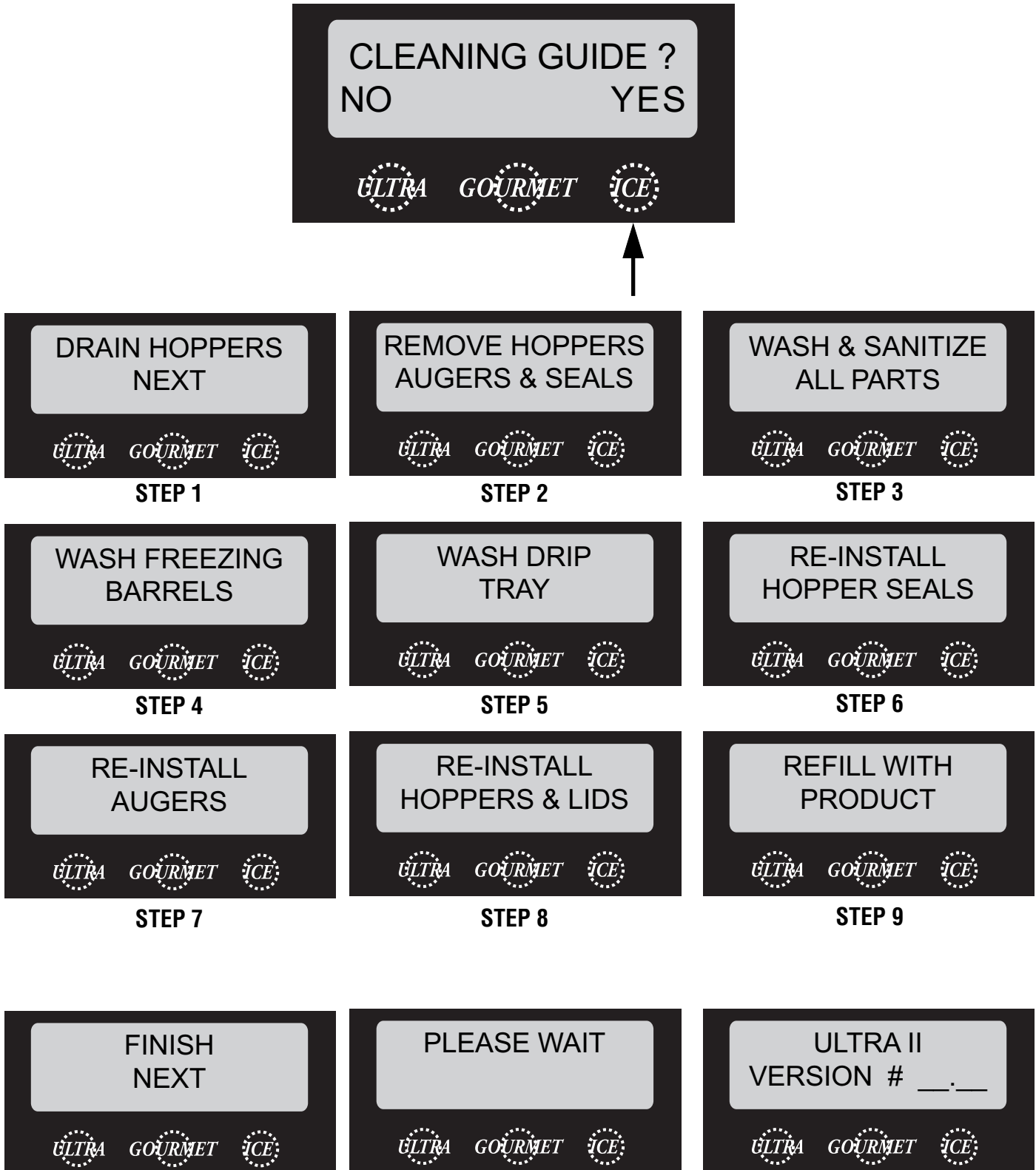

Set Consistency

This function allows the operator to adjust the ice consistency, or torque of each auger when answered YES (“ICE”). Two screens will appear for left and right. The operator can scroll through a range of a minimum of 1 (ULTRA) to a maximum of 16 (ICE). Factory default is 10.

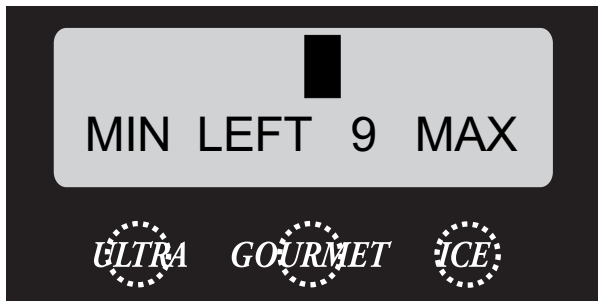
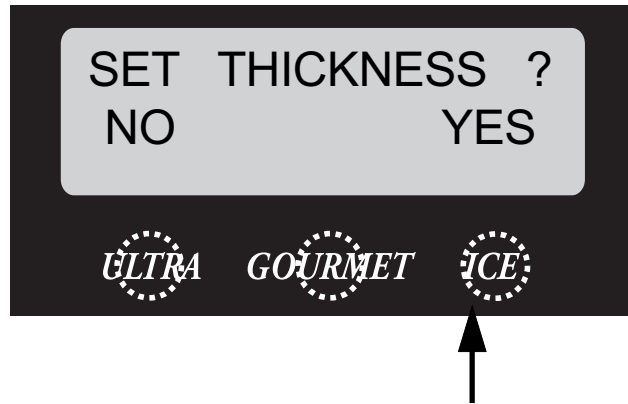

Test Augers

This function tests the operation of forward and reverse of each auger motor. Left auger appears first. Press the ICE hidden switch to toggle between OFF, FORWARD and REVERSE. Press GOURMET hidden switch to repeat the operation for the right auger motor. A one minute time out will return to the Home Screen.



Select NEXT to repeat process for Right Auger Test.

Set Time and Date

Selecting YES (ICE) allows the operator to set the DATE (YY MM DD) and TIME (HR MIN SEC) for display on the Home Screen.

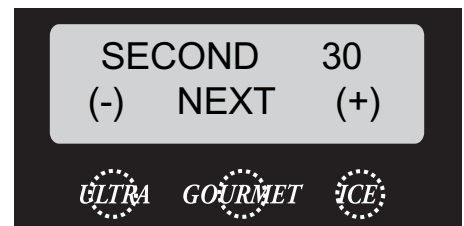
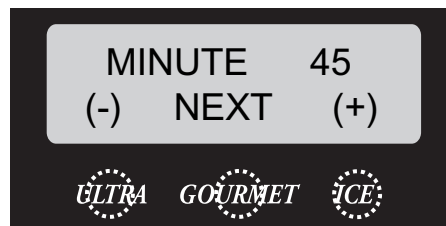
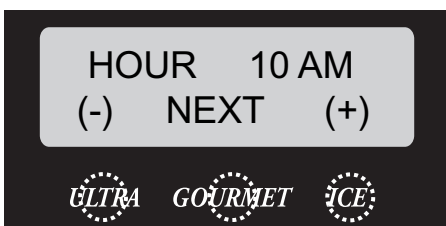
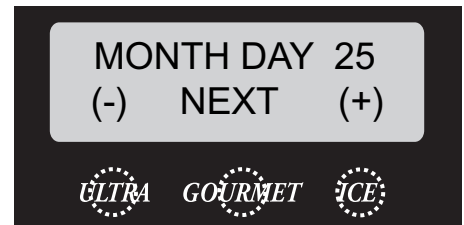
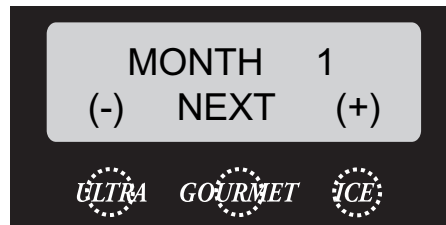
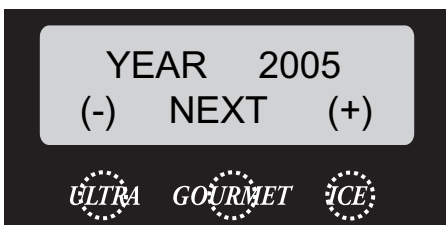

Password

From this screen, the operator must know the password before moving on to the remaining functions. The range is from 0 - 9999 with the factory default being **0**.

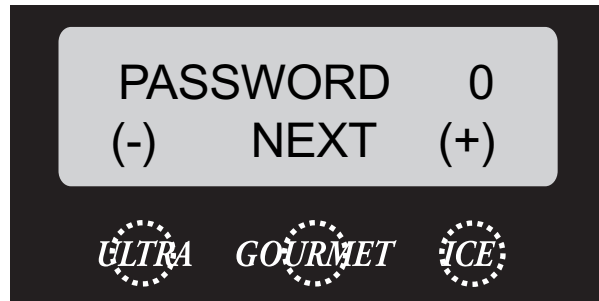

Set Language ? (Late Model Dispensers)

The setting of the Set Language mode allows the operator to scroll thru a list of languages stored in the software and select one for the display messages.



Set Night Time/Set Day Time

The setting of the Day/Night mode allows the dispenser to “power down” during off hours. The bottom corners displaying “ICE” will change to “CHILL” during the night mode. During the night mode, the product will be kept chilled to below 35°F. “ICE” reading will return after night mode elapses. With “OFF” representing 12:00 AM, the operator can scroll to the times desired for the night time mode to begin and end. (Some early models displayed the word “DISABLED” in place of the word “OFF”).

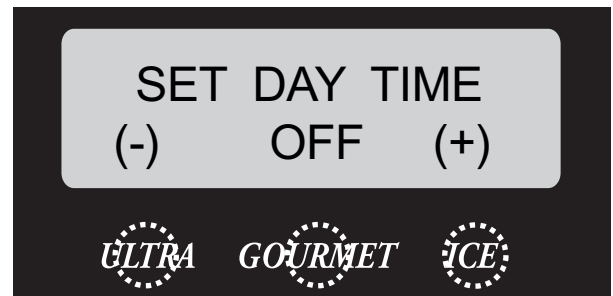

This feature allows the machine to defrost the product during day time operation. The defrost minutes setting will select the defrost time period. The freeze minutes setting will select the freeze time between defrost periods. These modes when activated will function anytime the machine is in day mode operation. The machine will automatically stay in the freeze mode for 2 hours after waking up from the night time mode. (This feature was not offered on some early models).

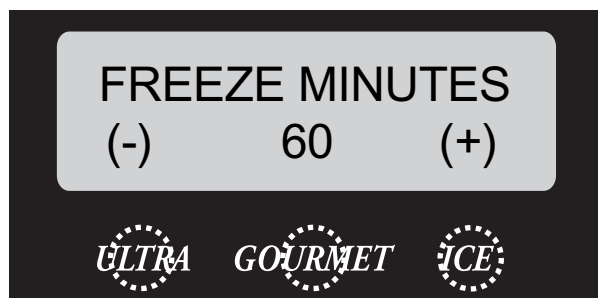

Preventive Maintenance Complete?

This function is used to reset a reminder message Preventive Maintenance Due every six months. The machine will not shut down if service is not performed. When the service is performed and the message is answered YES (ICE), the time and date is recorded for another six months to elapse. This feature can be DISABLED by pressing (-) ULTRA hidden switch. (Some early models displayed the word "ENABLED" in place of the word "ON").



Day To Clean Off (formerly Days....Disabled)

This function allows the operator to program a cleaning schedule from 1 to 14 days. The default screen is 0 or DISABLED. Selecting - or ULTRA will prompt the screen Days To Clean. Once a number of days is selected the screen will prompt two functions, CLEAN MESSAGE ONLY or CLEAN LOCKOUT. On the day selected, the display will toggle between DATE & TIME and CLEAN DUE TODAY. The dispenser will lock into night mode at midnight if “Clean Lockout” is activated. To reset the Clean Due Today message or lockout, two functions must be performed. Either power off the dispenser using the I/O (ON/OFF) switch and allow the barrels or cooling drums to warm over 50°F, or scroll to the Cleaning Guide and perform the cleaning service. The barrels will warm to over 50°F when cleaned with warm water and the message will disappear.

NOTE: The “CLEAN DUE TODAY” and “CLEAN DUE NOW” messages may be customized on late model machines. All users should be trained to know the machine needs cleaning when the custom message appears on the display.



Late Model Dispensers



Consistency Adjust Lock

This is an option of locking the Set Consistency function by selecting + (YES) or - (NO).

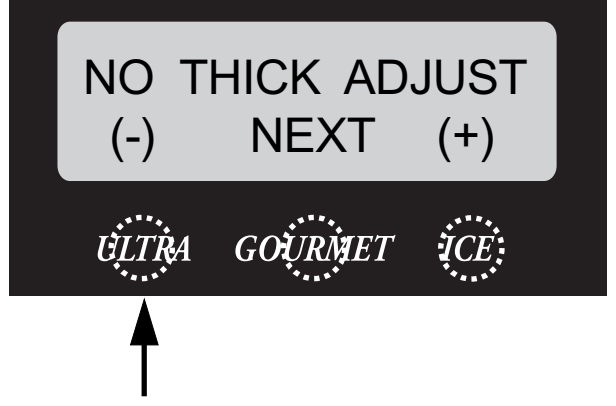
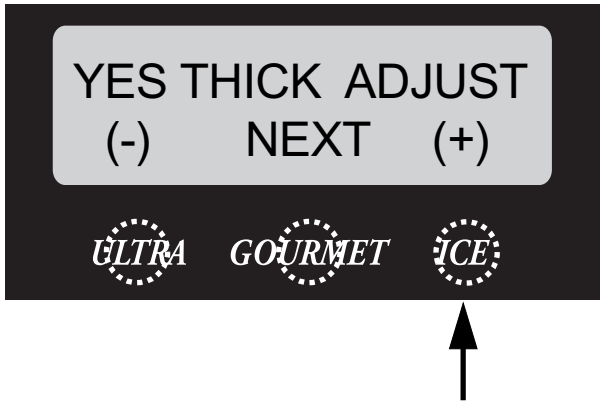

Switches Enabled

This function allows the operator to lockout the touch pad. Selecting + (ON) provides no time delay on switches except for the center (GOURMET) hidden switch. Selecting - (LOCKOUT) provides a five second hold to wake up the touch pad and a two minute time frame from last button pressed to make adjustments before returning to sleep mode (five second hold). (Some early models displayed the word "ENABLED" in place of the word "ON" and the word "DISABLED" in place of the word "LOCKOUT").

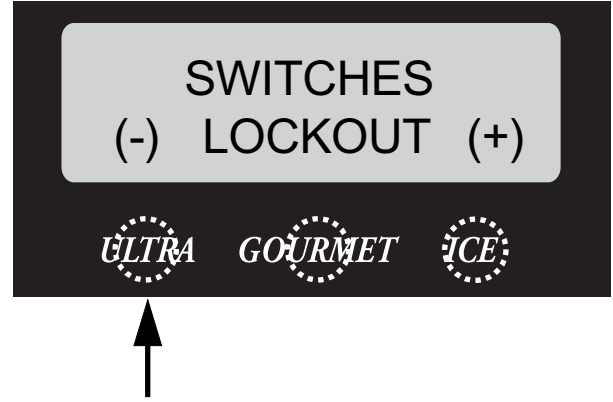
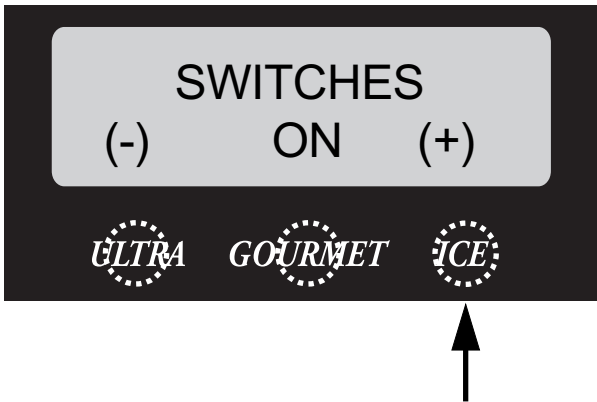

Refill Threshold (Late Model Dispensers with Refill Kit Installed only)

This function allows the operator to adjust the Refill Threshold depending on the type of product being dispensed.



Ad Messages Enabled (Late Model Dispensers)

This function allows the operator to create an AD Message that will toggle with the Home Screen messages.

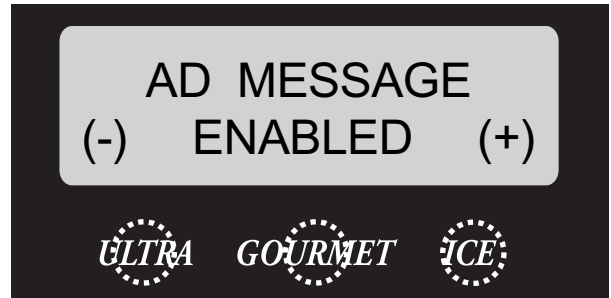

Enter Asset Number

This is the function to set the asset number using a range of 0 to 999999 (the factory default is 0). It is used to track the usage or service of an individual machine within a group.



Set Password

This is the function to set the password using a range of 0 to 9999 (the factory default is 0). When the password is set, the operator can only access the first four functions: Cleaning Guide, Set Consistency, Test Augers and Set Date & Time.

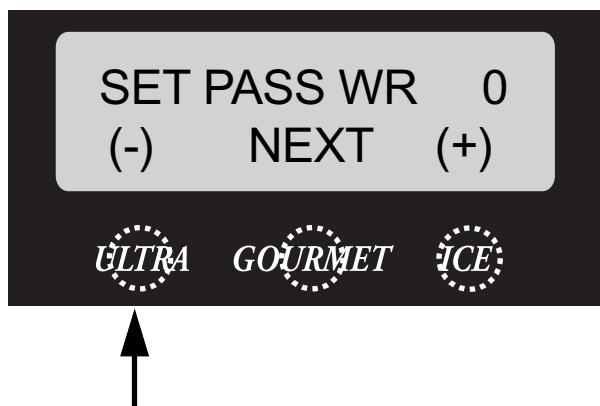

Restore Default?

Answering YES (ICE) to this function returns the unit back to preset factory constants.

1. Set Consistency ? **10**
2. Set Night Time - **DISABLED**
3. Set Day Time - **DISABLED**
4. 6 Month PM - **ENABLE**
5. Days....Disabled - **DISABLED**
6. Torque Adjust Lock - **YES**
7. Switches Enabled - **ENABLED**
8. Set Password - **0**
9. R Refill Threshold - **155**
10. L Refill Threshold - **155**
11. Cleaning Message - **RESET**
12. AD Message - **RESET**



Install Date

The following three screens will scroll after advancing past the function "Restore Defaults". The Install Date and Time is recorded when the dispenser is powered on for the first 100 hours. The Install Date and Time cannot be reset and is stored in permanent memory.

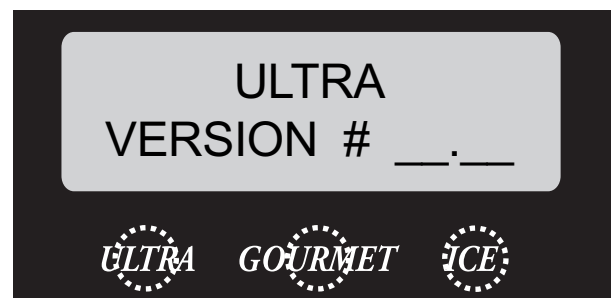
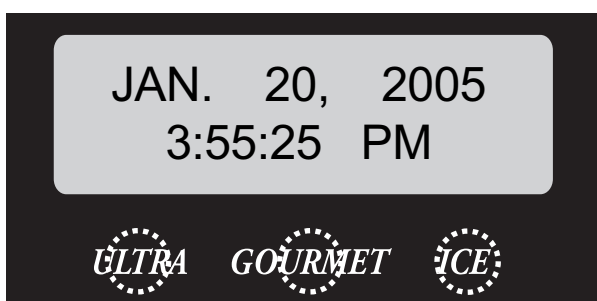

TEMP & TORQUE

Press and hold for five seconds the ULTRA and ICE hidden switches to display the TEMP & TORQUE. The temperature of each cooling drum and the hot gas temperature will toggle back and forth. The auger torque is displayed continuously. Press and release the ULTRA and ICE hidden switches to return to HOME SCREEN. The TEMP & TORQUE mode is typically used for service.

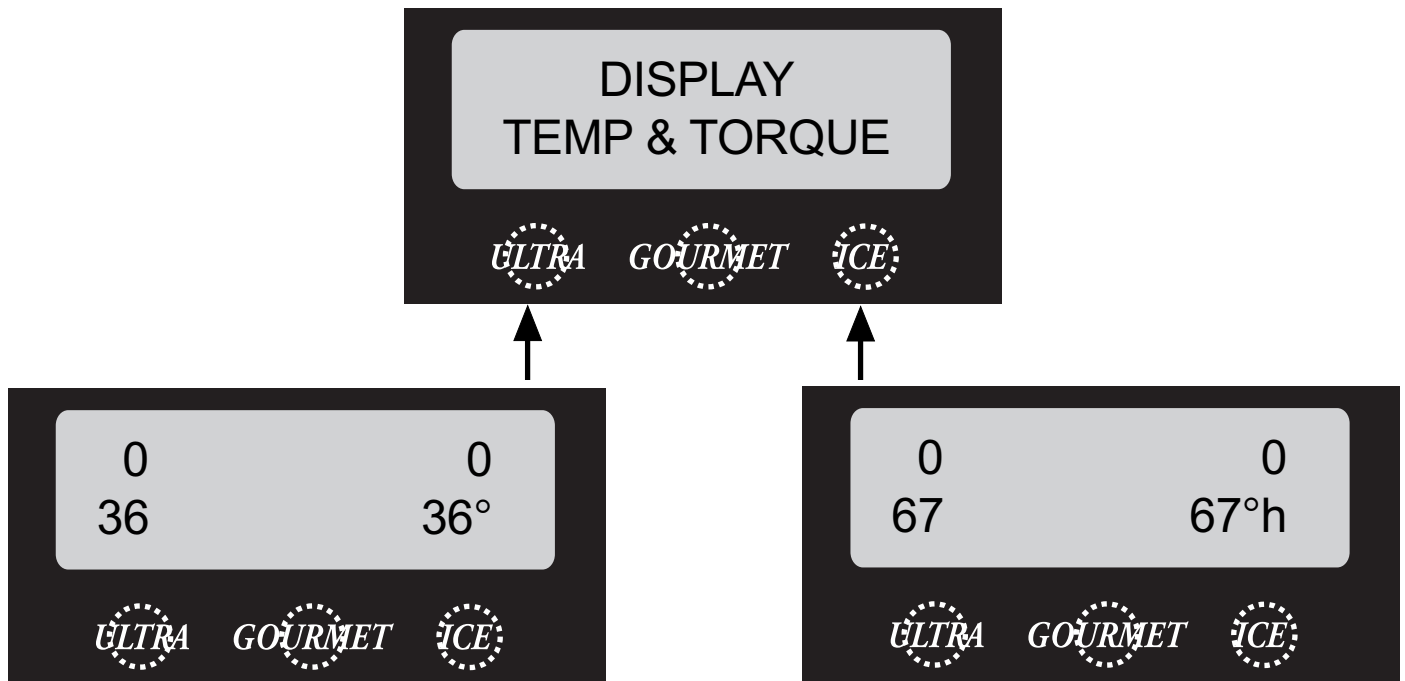

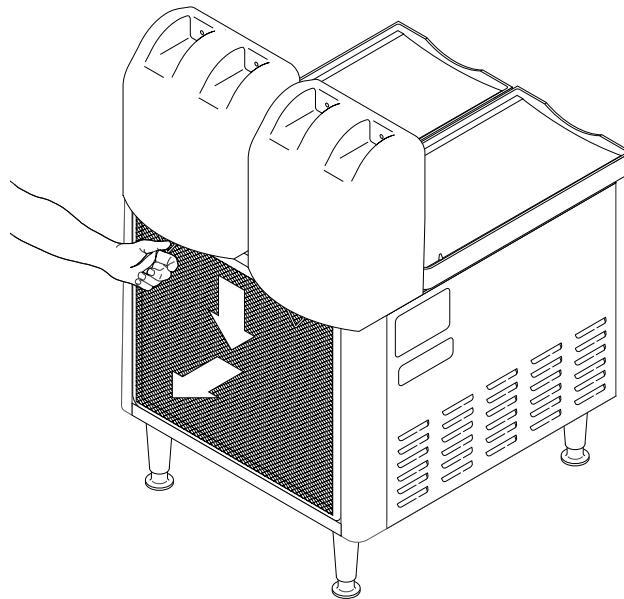

CLEAN FILTER

Monthly cleaning of the air filter is recommended. Should the air filter become dirty creating a high temperature problem, the unit will shut down until service is completed to correct the problem.





NOTE: Severe conditions may require more frequent cleaning.

USING THE DISPENSER FOR GRANITA-TYPE PRODUCTS

1. Lift the lid slightly for the selected hopper and slide back to gain access to the hopper.
2. Place the pre-mixed liquid product in the selected hopper.
3. a. Press and release the  (ON/OFF) switch to power on the dispenser.
b. Press and release the Left and/or Right  (ON/OFF) switch to start the Auger Motor and to turn on AutoFill when applicable.
c. Press and release the  (OFF/ICE/CHILL) switch and select ICE to begin the cooling process for the selected hopper.
4. Wait for the liquid to freeze to the desired consistency.

HINTS – Bunn-O-Matic recommends that the product in the dispenser be thawed each day, usually overnight. The ice granules get too large and a consistent product is difficult to maintain if left frozen for an extended period of time. Set the NIGHT mode for a few hours each night and return it to the DAY mode when the product has thawed sufficiently. You'll know it is in the NIGHT mode because the display will indicate NIGHT MODE.

USING THE DISPENSER FOR COLD LIQUID PRODUCTS

1. Lift the lid slightly for the selected hopper and slide back to gain access to the hopper.
2. Place the pre-mixed liquid product in the selected hopper.
3. a. Press and release the  (ON/OFF) switch to power on the dispenser.
b. Press and release the Left and/or Right  (ON/OFF) switch to start the Auger Motor and to turn on AutoFill when applicable.
c. Press and release the  (OFF/ICE/CHILL) switch and select CHILL to begin the cooling process for the selected hopper.
4. Wait for the liquid to cool.

OTHER RECOMMENDATIONS FOR YOUR DISPENSER

- Whether liquid concentrate or granulated powder, all product must be thoroughly mixed BEFORE adding it to the hoppers.

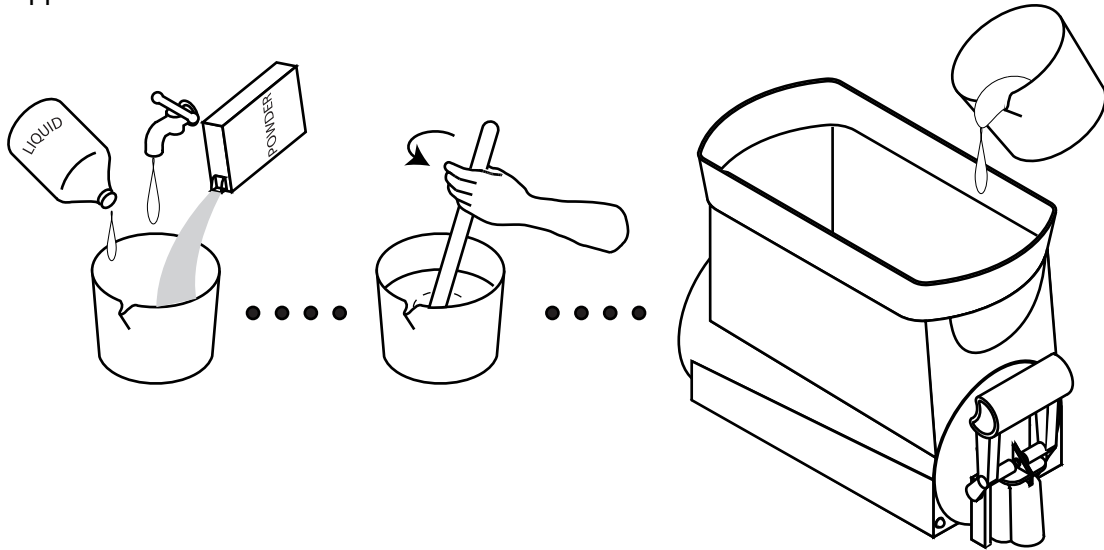

- For best results with granita-type products, use only products with an apparent brix of 12 or higher. Some products may work with an apparent brix as low as 9. Your experimentation with other products will be the best guide in this area.
- Keep the pre-mixed liquid product refrigerated. This reduces cooling/freezing time in the dispenser.
- Keep the hoppers topped-off during peak serving periods. Add pre-mixed liquid product as it is dispensed. This reduces the cooling/freezing time and assures you of always having product ready to dispense.
- Keep the product level in the hoppers higher than the auger. Air will become entrapped in the mixture resulting in a clouded foamy consistency.
- You may find it beneficial to turn down the ice controls to keep the ice granules from growing too large. Refer to *Programming The Dispenser* on page 11 for Setting the Consistency.
- Some products freeze at a lower temperature than others. You may notice frost or ice on the hoppers. This is normal and should not be a concern.
- Humidity in the air may cause sweating on the outside surfaces of the hoppers. This is to be expected and should not be a concern. The drip trays beneath the hoppers will capture this and cause it to flow to the lower drip tray for disposal.
- Some noises are to be expected during normal operation of the dispenser. By becoming familiar with the noises made during normal operation, you will be better able to listen for problems.

RECOMMENDED DAILY CLEANING

NOTE – Turn the power OFF to the dispenser before proceeding.

1. Empty all product from the hoppers. Disconnect the hopper lid lamp cords and remove the lids.

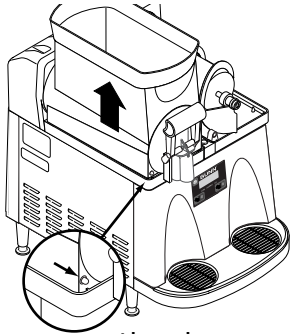

2. Depress the hopper lock plunger. Lift the hopper up slightly.

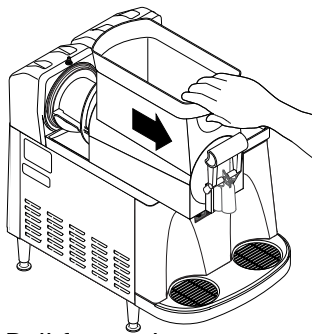

3. Pull forward to remove.

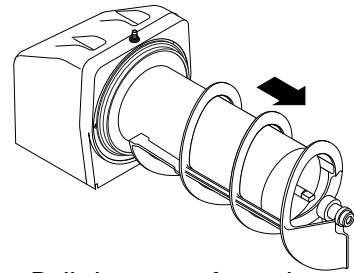

4. Pull the auger from the cooling drum.

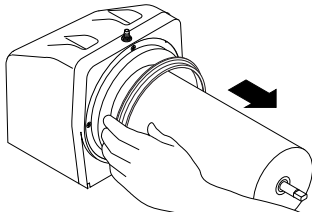

5. Remove the cooling drum seal from the rear of the drum.

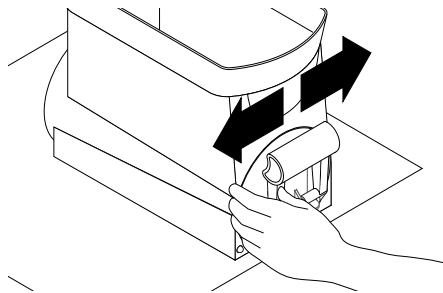

6. **Caution:** The faucet valve is under spring tension. Spread one side of the handle first, then the other and disconnect from the hopper.

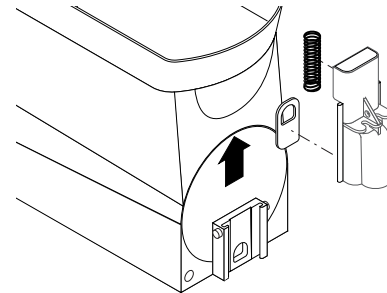

7. Carefully slide the faucet valve up to remove the spring and faucet seal. Extra care should be taken when handling the seal to prevent damage. Do not fold the seal as this will cause damage to the Teflon® sealing surface.

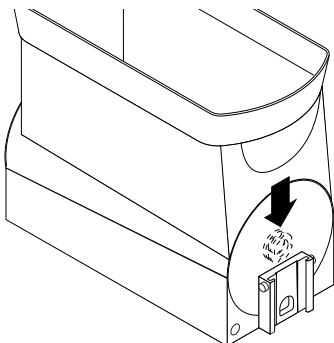

8. Remove the auger nose bushing from inside the hopper.

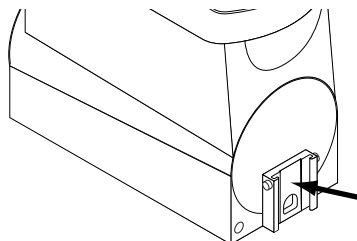

9. Care must be taken to ensure this surface does not get scratched during cleaning. Deep scratches could cause leakage around the seal.

10. Place all parts in a clean sink with mild hot water (120°F) and sanitizer solution. Allow all parts to soak for at least 5 minutes. Carefully wash all components with a clean wash cloth in the hot water and sanitizer solution. Use a clean, soft bristle brush as needed for the smaller components and tight areas. **Do not immerse hopper lids.** Use a commercial sanitizer that has 100 ppm of available chlorine with a concentration level of at least 3% available chlorine (KAY-5 Sanitizer). Follow the sanitizer's mixing instructions to ensure 100 ppm of available chlorine.

11. Wash the drums, hopper drip trays, top covers, and outer enclosure using a clean wash cloth that has been dampened in the hot water and sanitizer solution. Pay particular attention to the shaft area and make sure it is thoroughly cleaned and sanitized.

12. Thoroughly rinse all surfaces with a clean wash cloth that has been dampened with hot water. Wipe dry with a clean dry wash cloth before reassembling the dispenser.

NOTE – Although most parts are dishwasher safe, they may be affected by the chemicals in some commercial sanitizing agents. Do not place the hopper nor hopper lids in a dishwasher. Rinse thoroughly before assembly.

INSTALLATION

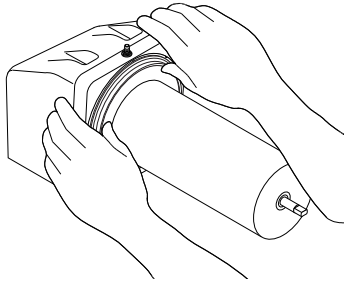

1. Install the seals over the flange at the rear of the cooling drums and press the seals firmly into place as shown.

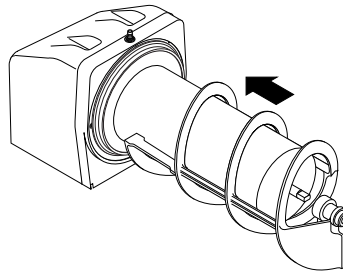

2. Align the auger shafts with the augers. Push the augers as far as they will go and rotate them so the flat face of the auger shaft is aligned with the flat face of the auger nose.

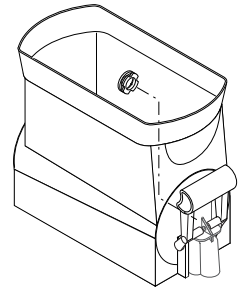

3. Install auger nose bushing into inside front of hopper.

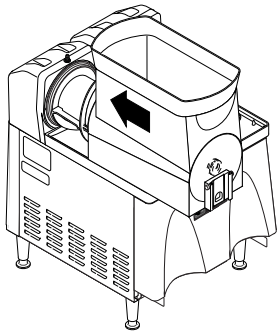

4. Thoroughly rinse the hoppers and install them over the augers and cooling drums.

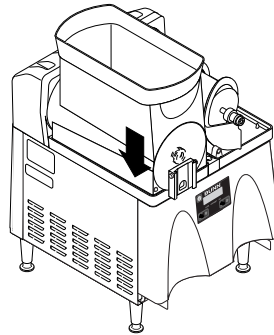

5. Slide them into place and push them down until the hopper lock plungers snap into place.

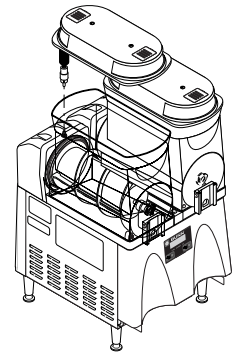

6. Set the lids on the hoppers and plug in the hopper lid lamp cords.

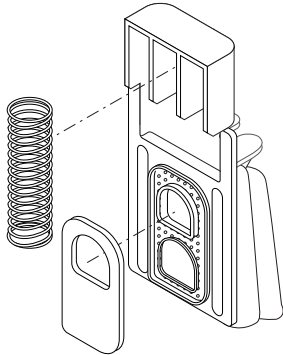

7. Position the faucet seal and return spring in the faucet valve.

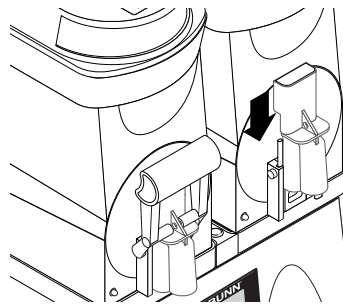

8. Slide the faucet valve assembly into place on the hopper.

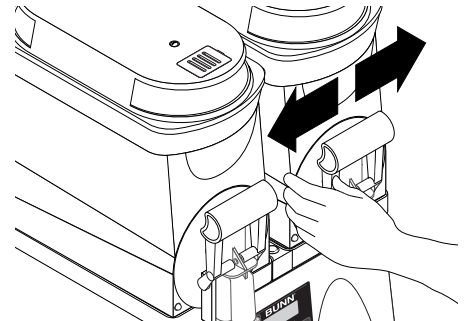

9. Press down on the valve to compress the spring. Position the faucet handle over the faucet valve one side at a time and snap into place on the hopper.

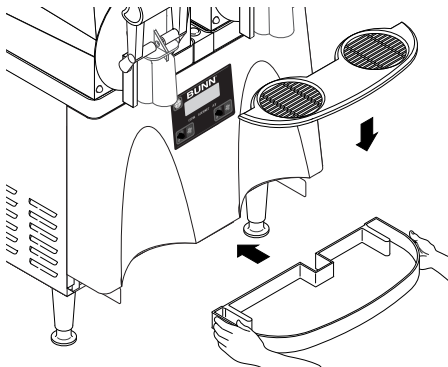

10. Assemble the drip tray.

Auto-fill Cleaning Instructions (With Brixing Pump Installed)

Materials required

1. Non-sudsing liquid detergent (such as common household automatic dishwasher liquid detergent).
2. Household bleach (Sodium chloride solution: 5.25%) or equivalent.
3. Clean five (5) gallon bucket.
4. Measuring Cup
5. An adaptor is needed to hold the Q.C.D. fitting on the concentrate suction line open. A connector from an empty bag will work.

Sanitizing Procedure

1. Fill bucket with 4 gallons of warm water (120-180 deg. F).
2. Measure 4 ounces (1/2 cup) of the liquid detergent and add to the water.
3. Measure 2 ounces (1/4 cup) of bleach and add to the water, then stir, mixing evenly.
4. Ensure that the refill for the Ultra hopper is turned off.
5. Empty all product from the Ultra hopper
6. Disconnect the concentrate line from the B-I-B and install adaptor on the quick disconnect so the line is open to the sanitizing solution. Place concentrate inlet line into the bucket to that the Q.C.D. will stay at the bottom.
7. Press the auger button to turn on the "Auger Refill On" feature.
8. Allow system to run until the hopper is about 1/4 full then turn off refill.
9. Switch three way sanitize valve to the Sanitize position.
10. Turn refill system back on and let run until the hopper is almost full then turn off refill.
11. Allow sanitizer to sit in system for 10 minutes.
12. Drain sanitizer from hopper and remove the Q.C.D. from the sanitizer bucket.
13. Empty remaining sanitizer and refill bucket with about 2 gallons of warm (120-180 deg. F) rinse water.
14. Turn sanitize valve back to dispense position.
15. Place Q.C.D. into rinse water and turn on refill system.
16. Run until hopper is about 1/4 full.
17. Turn off refill system and drain hoppers.
18. Refer to the recommended daily cleaning instructions on page 26 and follow these steps to clean the hopper, lid and other dispense parts.

REQUIRED REGULAR MAINTENANCE:

Semi Annual:

Bunn #34245.0000 is required to perform the semi annual Preventive maintenance:

Note: Service caused by failure to perform required maintenance is not covered by warranty.

The following instructions apply to one hopper only; repeat each step for all hoppers.

Kit Contents

Inventory this kit for completeness before proceeding.

<u>Part Number</u>	<u>Qty.</u>	<u>Description</u>
27446.0000	2	Lamps, T-5 Wedgebase Min.
26781.0000	2	Auger Shaft Bushing (Blue)
26782.0001	2	Cooling Drum Seal
32079.0000	2	Hopper/Drum Seal
32268.0000	2	Seal, Faucet (Clear)
29563.0000	-	Lubricant ("Krytox")
28395.0000	1	Seal Insertion Tool

INSTRUCTIONS

WARNING - Disconnect the dispenser from the power source before the removal of any panel or the replacement of any component.

1. Drain, remove and clean hopper; refer to the Operating and Service Manual for proper cleaning procedures. Discard the hopper/drum seal and faucet seal.
2. Remove the #8 locking screws securing auger motor cover to the cooling drum mount assembly; remove cover and set aside for reassembly.
3. Remove the #8 locking screw on the lower right side (viewed from front) of the auger motor mounting bracket securing the auger motor run capacitor. Set capacitor aside with wires attached.
4. Disconnect the auger motor terminal from the terminal on the main wiring harness.
5. Remove the remaining #8 locking screws securing the cooling drum mounting bracket. Remove motor with mounting bracket.

NOTE: When removing or installing motor and shaft assemblies, be sure the motor and shaft pins are turned to a position that will clear the torque sensor circuit board.

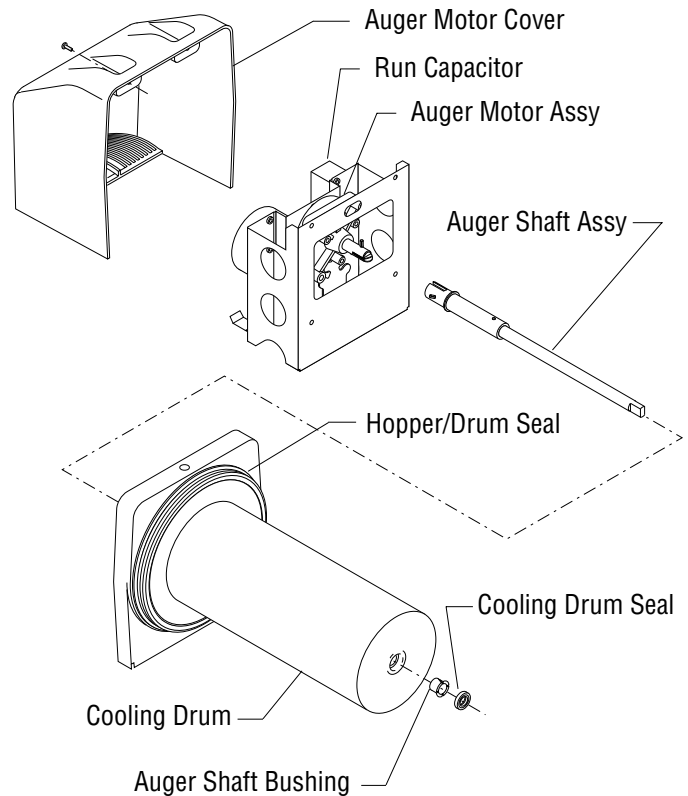
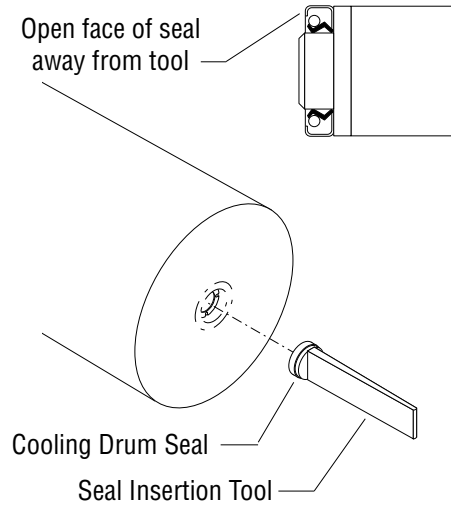

FIG 1

P2528

REQUIRED REGULAR MAINTENANCE (Continued)

6. Pull the auger shaft assembly straight out of cooling drum. Inspect the shaft for abnormal wear.
7. From the front of dispenser, remove the seal and blue bushing from cooling drum and discard them.
8. Clean seal and bushing surfaces of the cooling drum very thoroughly.
9. Refer to FIG 1, and slip new blue bushing into cooling drum.
10. Place seal on insertion tool #28395.0000 as shown in FIG 2. Make sure open face of seal is toward cooling drum.
11. Apply a small amount of food grade lubricant (Bunn #M2568.1000) to inside diameter of seal. Push seal into bore until it is firmly seated; remove tool.
12. Place a small amount of #29563.0000 “Krytox” lubricant (provided in kit in a plastic cap) on the end of the motor shaft (about 1 1/2”) and a thin film in the groove. Install auger shaft assembly onto the motor shaft. See FIG 3. Do not use too much “Krytox” lubricant.



P1760

FIG 2

NOTE: This is the only place “Krytox” lubricant is used.

13. Assemble motor/shaft assembly as shown in FIG 3, then install assembly into cooling drum. Make sure the pins do not hit the sensor board and cooling drum seal is not dislodged as the shaft passes through.
14. Secure motor and capacitor to the cooling drum mounting bracket. Install rear motor cover.
15. Refer to the Installation and Operating Manual for hopper assembly and installation procedures. Install new hopper/drum seals and faucet seals included in the kit. See FIG 1 & 4.
16. Remove and clean condenser air filter. See FIG 5.
17. Refer to the Installation and Operating Manual, “Menu Function Index”. Scroll to menu “PM Complete?” and answer “YES” to reset the reminder message “PM Due”.

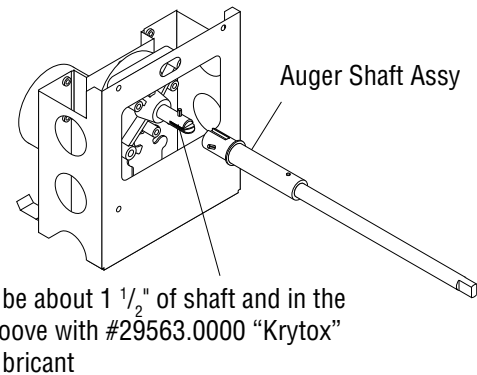

P2529

FIG 3

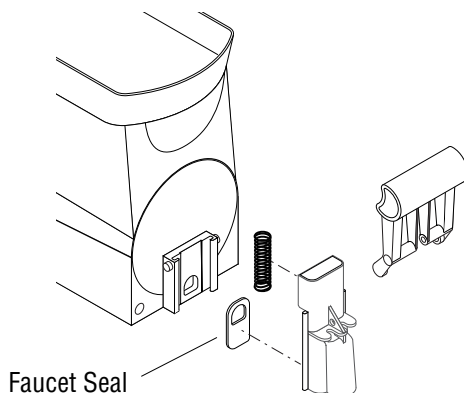

P2531

FIG 4

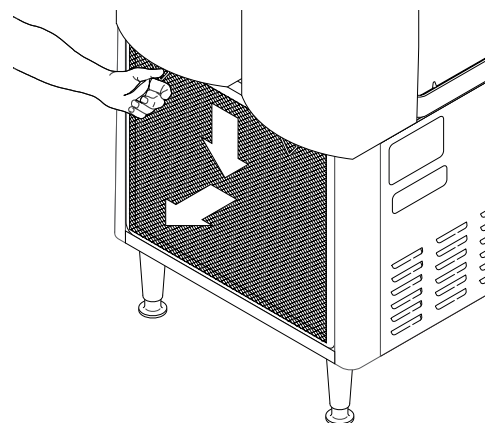

P2532

FIG 5

SCHEMATIC WIRING DIAGRAM ULTRA-2

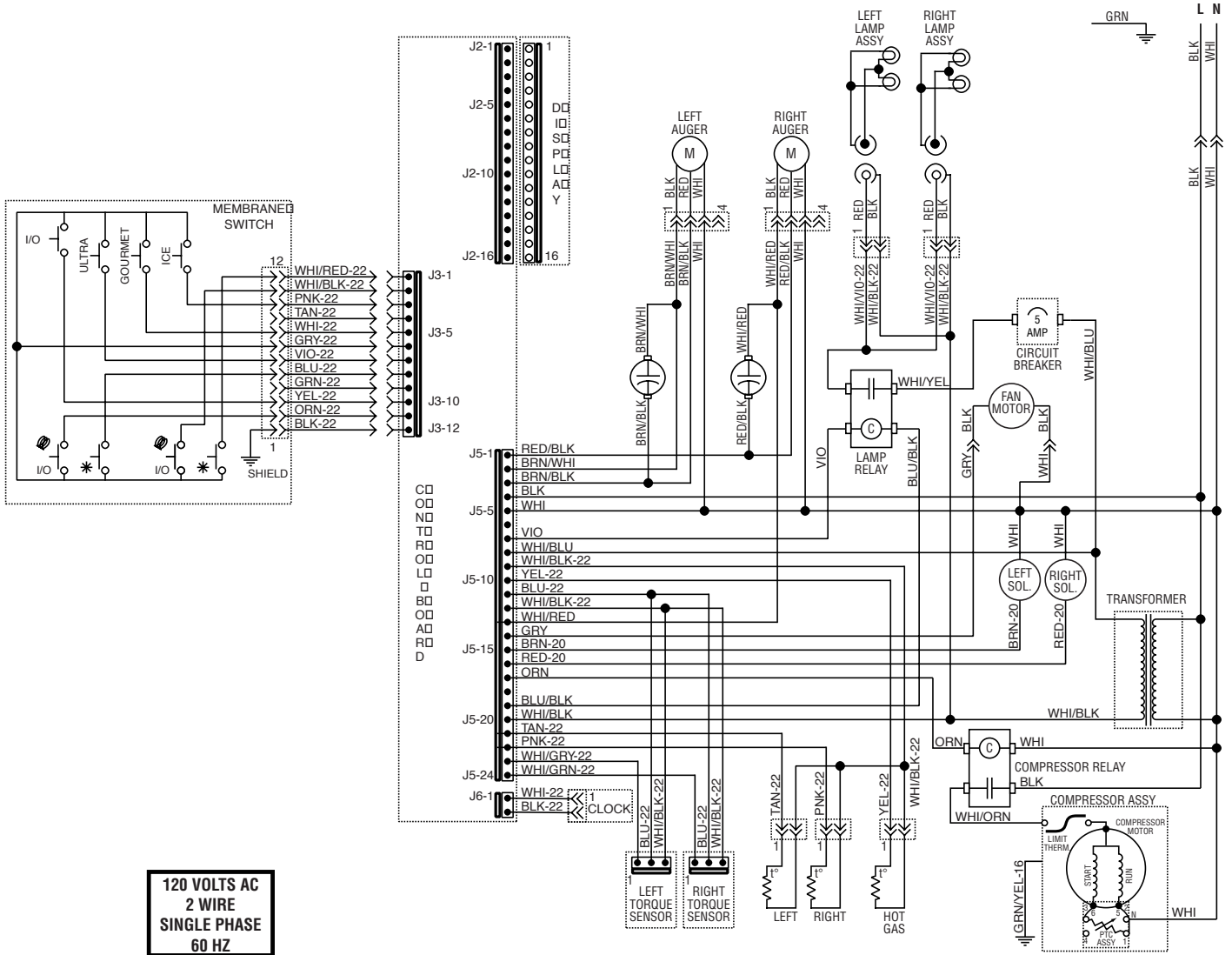

SCHEMATIC WIRING DIAGRAM ULTRA-2A

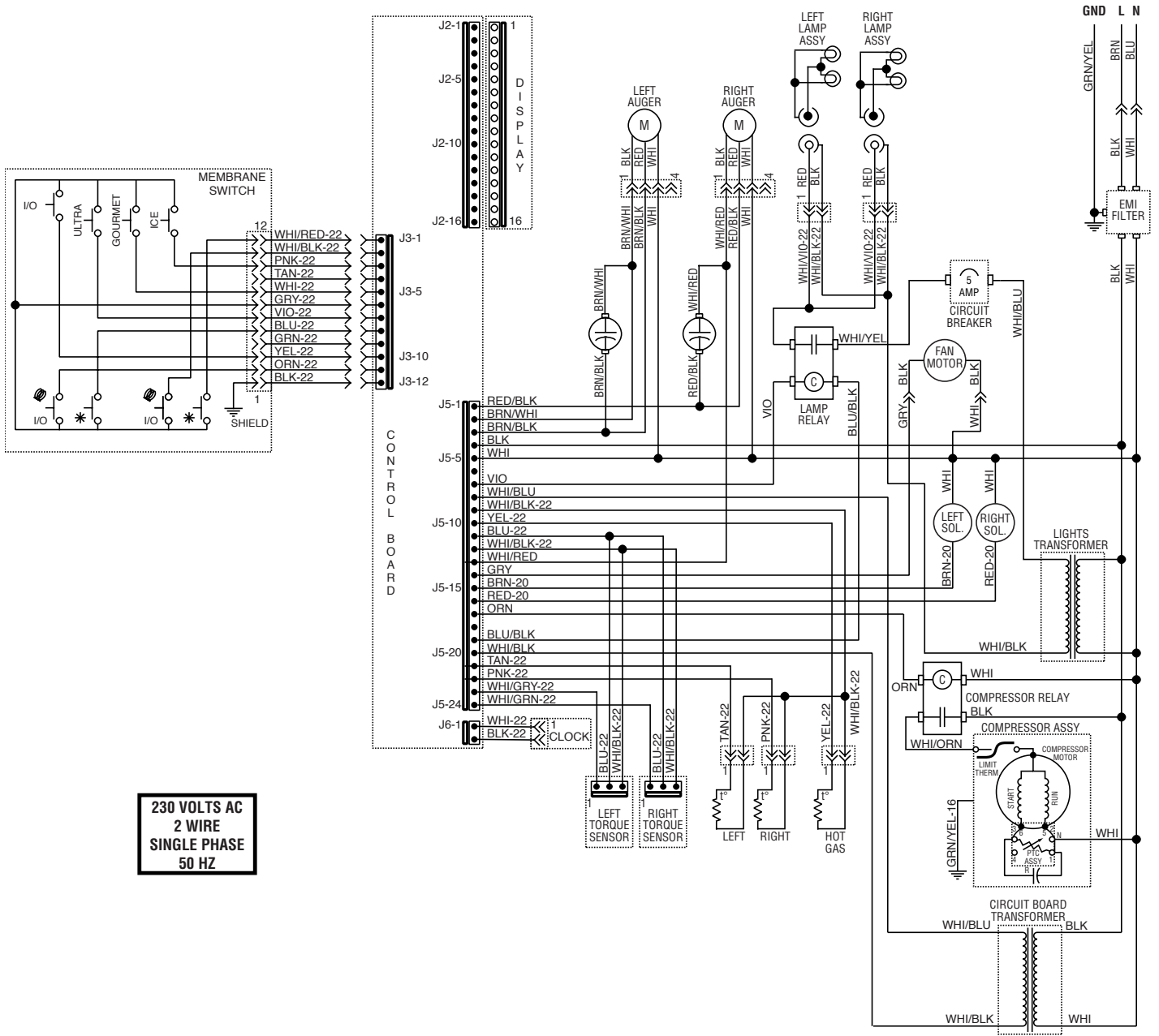

230 VOLTS AC
2 WIRE
SINGLE PHASE
50 HZ

SCHEMATIC WIRING DIAGRAM ULTRA-2 (Late Model Dispensers)

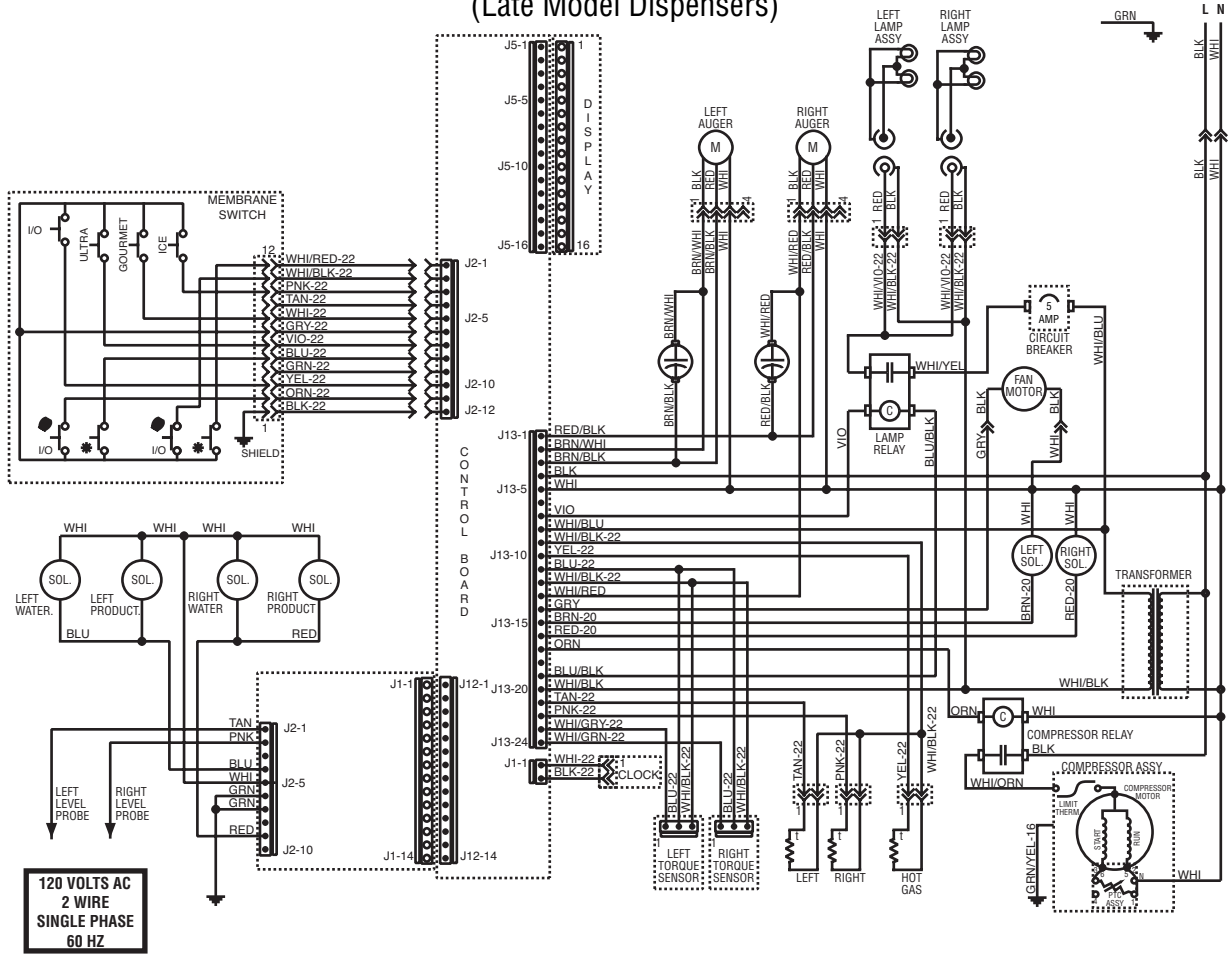

SCHEMATIC WIRING DIAGRAM ULTRA-2A (Late Model Dispensers)

