

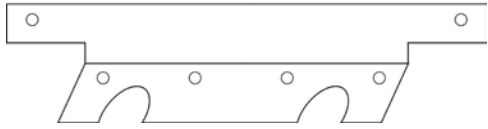



## Installation & Assembly Microwave Oven Bracket Installation Instruction

**For use with the following Avanti models:**

**Microwaves – MO7082MB, MO7191TW, MO7192TB, MO7103SST& MO8003BT**

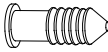
**Refrigerators – Can be used with all Compact, Midsize & Counterhigh models except the RM4550W-2, RM4551B-2, RM4589SS-2 and BCA4561B-2**

Parts List & Hardware	Before you start this installation make sure you have all the parts listed below. Read entire installation sheet before you start assembly of this item.			
	Part Number	Qty	Description	
A	MOM9705	1	Mounting Bracket	
B	9705-001	1	Allen Wrench	
C	9705-002	4	No. 8 x 1" Phillips Pan Head Sheet Metal Screw	
D	9705-003	4	Plastic Anchor (1/4" x 1")	
E	9705-004	4	No. 8 x 5/8 Phillips Hex Head Self Tapping Screw & Washer	

### Installation Procedures:

#### 1) Bracket Configuration:

Holes (A) and (B) are the existing holes in the upper part of the Metal bracket to be attached to the microwave oven. Holes (C), (D), (E) and (F) are also existing holes in the lower part of the Metal bracket to be installed on to the refrigerator. See illustration #1.

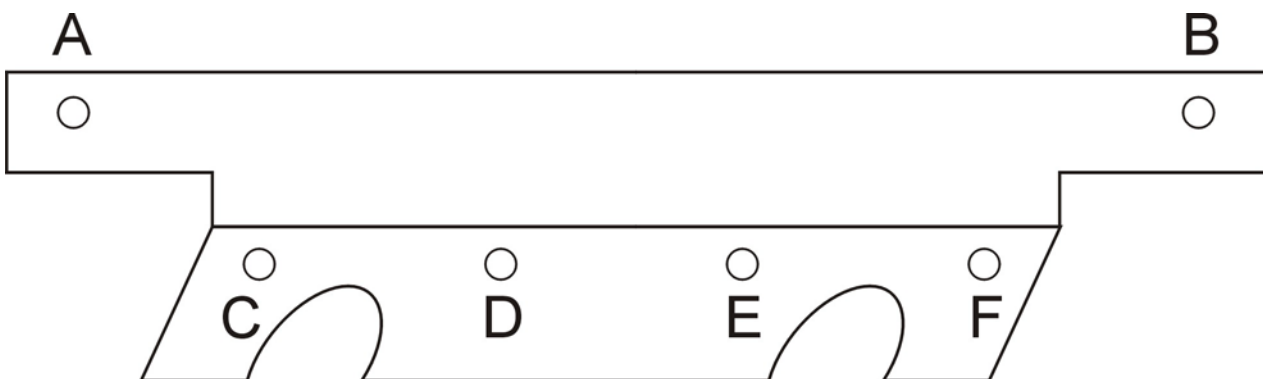

Illustration #1

Instructions below are for refrigerators with a solid top. If installing on refrigerator with a decorative (plastic) top skip to Step #4

**2) Installation of the lower side of the Metal bracket to the Refrigerator:**

Lay and center the Metal bracket on top of the refrigerator as close to the back as possible.

Using the four (4) existing holes on the bracket as a guide, mark the locations where the Self Tapping Screws are to be installed (C), (D), (E) and (F).

**3) Affixing the Metal bracket to the refrigerator**

Align the four (4) holes of the lower part of the metal bracket and attach the bracket using the (4) Self Tapping screws provided. See illustration #2.

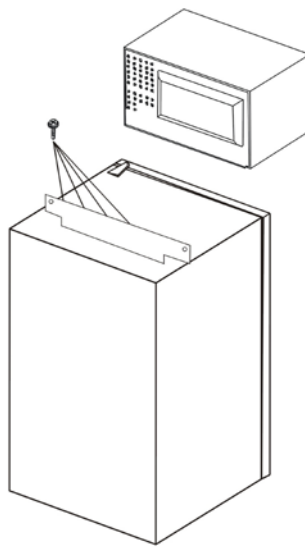

Illustration # 2

**4) Drilling four holes to the Refrigerator:** *For refrigerators with decorative (plastic) top*

After marking the locations of the four (4) holes, remove the bracket from the top of the refrigerator and proceed drilling the four (4) holes with a 1/4" drill bit into the rear portion of the top of the Refrigerator. Be careful not to drill too deep and risk damaging the sealed system tubing or liner. See illustration #3

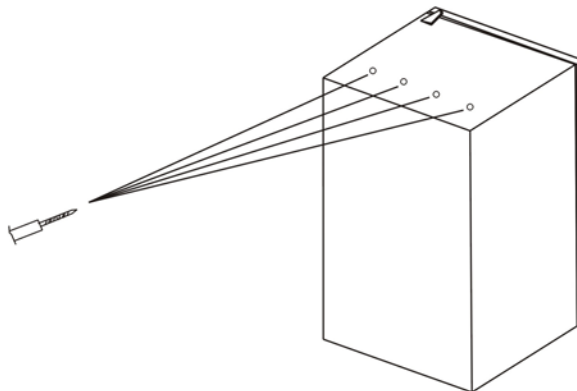

Illustration # 3

**5) Inserting the Plastic Anchors to the Refrigerator:**

Insert the four (4) Plastic Anchors provided into the four (4) holes (step 3) in the rear portion of the top of the refrigerator. See illustration # 2

**6) Affixing the Metal bracket to the refrigerator**

Align the four (4) holes of the lower part of the metal bracket to meet the four (4) plastic anchors installed in previous step 4. Attach the lower part of the metal bracket to the refrigerator.

Secure with the four (4) Phillips Pan Head Sheet Metal screws (provided) using a Phillips head screwdriver. See illustration #4

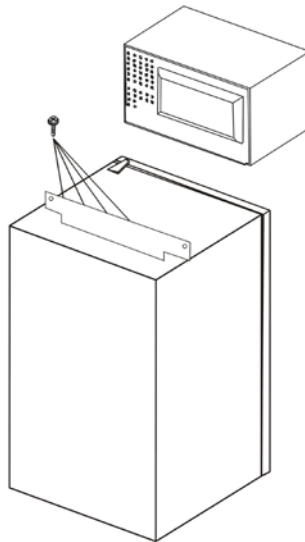

Illustration # 4

**6) Installation of the upper side of the Metal bracket to the Microwave:**

Using the Allen wrench (included) remove the (2) two self tapping screws (1) from each of the lower rear corners at the back of the Microwave oven.

Place the Microwave oven in place and align the holes (A) and (B) to the lower rear holes of the Microwave oven. Replace the screws removed previously using the Allen wrench. See illustration # 5.

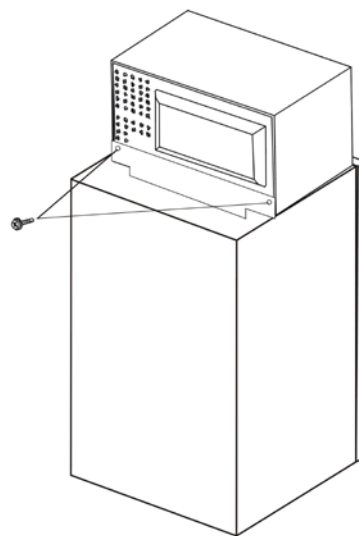

Illustration # 5

**7) Side view of completed installation.**

Once you have completed all 6 of the above steps the completed Metal bracket will appear as shown in illustration # 5.

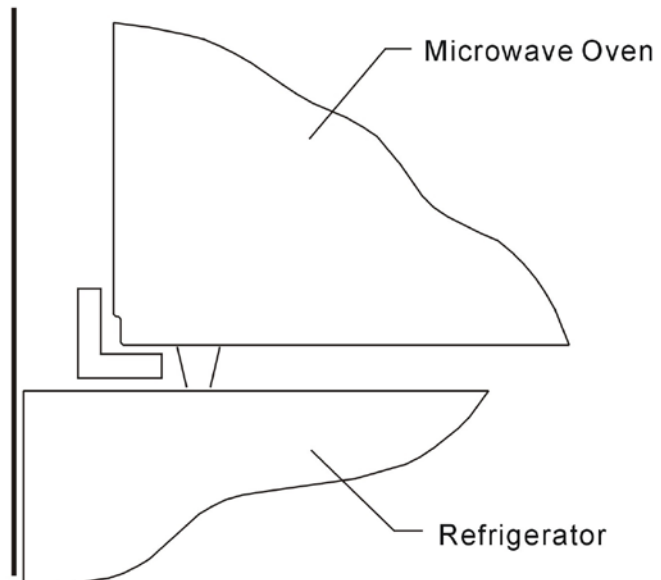

Illustration # 5