

MCS-425 Microwave sensor switch Installation Instruction

How to use

1. Before turning-on this unit, please make sure all cables are connected properly.
2. The mounting height is 230 cm.
3. Antenna angle (D) is adjustable, the higher the antenna angle, the wider the detection range that can be detected. Instead, the lower the antenna angle, the narrower the detection range that can be detected.
4. Turn the (A) clockwise to increase the antenna detection range, or the counter-clockwise turn to decrease the antenna detection range.
5. Turn the (C) clockwise to increase the relay actuation time, or the counter-clockwise turn to decrease the relay actuation time.

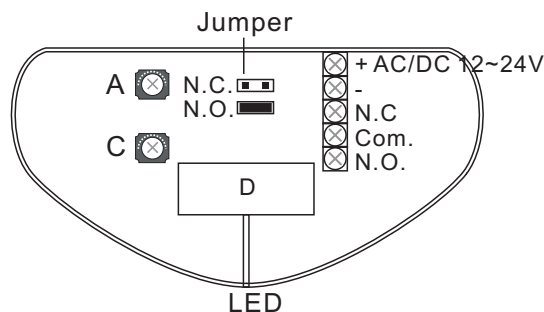

A Clockwise turns on switch to is biggest.

C Clockwise turns on switch to increase the relay actuation time. (0.5 ~ 4 Seconds)

Relay mode and Jumper Status

Jumper mode	Relay Normal Status	Detects the signal Relay Action Status	No power Relay Statue
N.O.	N.O.=OPEN	N.O.=CLOSED	N.O.=OPEN
	N.C.=CLOSED	N.C.=OPEN	N.C.=CLOSED
	LED OFF	LED ON	LED OFF
N.C.	N.O.=CLOSED	N.O.=OPEN	N.O.=OPEN
	N.C.=OPEN	N.C.=CLOSED	N.C.=CLOSED
	LED ON	LED OFF	LED OFF

The factory settings

- Microwave Antenna stand angel: 35°
- Jumper: N.O. (Normal open)
- Adjustment resistance:
 - (A) Clockwise turns on switch to is biggest.
 - (C) Clockwise turns on switch to increase the relay actuation time.
- Detection Range: 4.5 meter

Specifications

- Power Input: 12 V~24V AC/DC (self-regulating)
- Maximum current: 80 mA
- Frequency: 10.525 GHz
- Relay rated 3A, 125VAC / 30VDC
- Relay actuation time: 0.5 ~ 4 Seconds
- Sensor Angle: 7.5° ~ 82.5°
- Operating Temperature Range: -20°C ~ +55°C
- Dimensions: 122.5(W) * 72(H) * 63 (D)mm

Application

MCS-425 microwave sensor switch can be used with access control system which it can work as a request to exit. The diagrams below illustrate the two recommended ways of installing the MCS-425 and access control devices after power input (power on).

Fig. A The connection for fail-safe Lock devices :

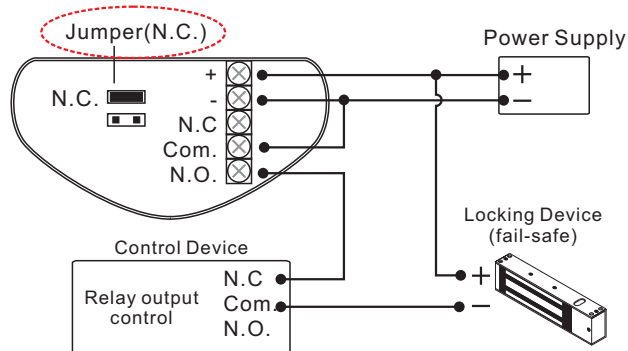

Fig. B The connection for fail-secure Lock devices :

