

1	INSTRUCTIONS FOR SAFE AND PROPER USE	4
2	INSTALLATION OF THE APPLIANCE	6
3	DESCRIPTION OF CONTROLS	9
4	USE OF THE COOKING HOB	11
5	USE OF THE OVEN	12
6	ELECTRONIC PROGRAMMER (ONLY ON EQUIPPED MODELS)	14
7	CLEANING AND MAINTENANCE	16
8	EXTRAORDINARY MAINTENANCE	18



THESE INSTRUCTIONS ARE VALID ONLY FOR THE END USER COUNTRIES WHOSE IDENTIFICATION SYMBOLS APPEAR ON THE COVER OF THIS MANUAL.



INSTRUCTIONS FOR THE INSTALLER: these are for the **qualified technician** who must carry out a suitable check of the gas system, install the appliance, set it functioning and carry out an inspection test.



INSTRUCTIONS FOR THE USER: these contain user advice, description of the commands and the correct procedures for cleaning and maintenance of the appliance.

1 INSTRUCTIONS FOR SAFE AND PROPER USE



THIS MANUAL IS AN INTEGRAL PART OF THE APPLIANCE AND THEREFORE MUST BE KEPT IN ITS ENTIRETY AND IN AN ACCESSIBLE PLACE FOR THE WHOLE WORKING LIFE OF THE COOKER. WE ADVISE READING THIS MANUAL AND ALL THE INSTRUCTIONS THEREIN BEFORE USING THE COOKER. ALSO KEEP THE SERIES OF NOZZLES SUPPLIED. INSTALLATION MUST BE CARRIED OUT BY QUALIFIED PERSONNEL IN ACCORDANCE WITH THE REGULATIONS IN FORCE. THIS APPLIANCE IS INTENDED FOR DOMESTIC USES AND CONFORMS TO CURRENT **REGULATIONS IN FORCE**. THE APPLIANCE HAS BEEN BUILT TO CARRY OUT THE FOLLOWING FUNCTIONS: **COOKING AND HEATING-UP OF FOOD**. ALL OTHER USES ARE CONSIDERED IMPROPER.

THE MANUFACTURER DECLINES ALL RESPONSIBILITY FOR IMPROPER USE.



DO NOT LEAVE THE PACKING IN THE HOME ENVIRONMENT. SEPARATE THE VARIOUS WASTE MATERIALS AND TAKE THEM TO THE NEAREST SPECIAL GARBAGE COLLECTION CENTRE.

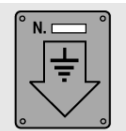

IT IS COMPULSORY THAT THE APPLIANCE BE GROUNDED ACCORDING TO THE METHODS REQUIRED BY SAFETY RULES.

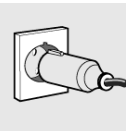

THE PLUG TO BE CONNECTED TO THE POWER CABLE AND THE SOCKET MUST BE THE SAME TYPE AND MUST CONFORM TO CURRENT REGULATIONS.

THE SOCKET MUST BE ACCESSIBLE AFTER THE APPLIANCE HAS BEEN BUILT IN.

NEVER UNPLUG BY PULLING ON THE CABLE.



IMMEDIATELY AFTER INSTALLATION CARRY OUT A BRIEF INSPECTION TEST OF THE APPLIANCE, FOLLOWING THE INSTRUCTIONS BELOW. SHOULD THE APPLIANCE NOT FUNCTION, DISCONNECT IT FROM THE SUPPLY AND CALL THE NEAREST TECHNICAL ASSISTANCE CENTRE.

NEVER ATTEMPT TO REPAIR THE APPLIANCE.



WHEN NOT IN USE, MAKE SURE THAT THE CONTROL KNOBS ARE IN THE CORRECT (OFF) POSITION **0**.



NEVER PUT INFLAMMABLE OBJECTS IN THE OVEN: THEY COULD BE ACCIDENTALLY LIGHTED AND CAUSE FIRES.

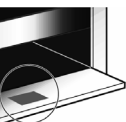

THE I.D. PLATE WITH TECHNICAL DATA, SERIAL NUMBER AND BRAND NAME IS POSITIONED VISIBLY IN THE STORAGE COMPARTMENT.

THE PLATE MUST NOT BE REMOVED.



DO NOT PUT PANS WITHOUT PERFECTLY SMOOTH AND FLAT BOTTOMS ON THE HOB GRIDS.



DURING USE THE APPLIANCE BECOMES VERY HOT. TAKE CARE NOT TO TOUCH THE HEATING ELEMENTS INSIDE THE OVEN.

Introduction

GB-IE



THE APPLIANCE IS DESIGNED FOR USE BY ADULTS. DO NOT ALLOW CHILDREN TO GO NEAR OR PLAY WITH IT.



IF THE APPLIANCE IS TO BE POSITIONED ON A PLATFORM IT MUST BE INSTALLED IN SUCH A WAY AS TO PREVENT IT FROM SLIPPING OFF THE FORMER.



ATTENTION: IN CASE OF A CRACK BEING DETECTED IN THE GLAZED CERAMIC HOB, IMMEDIATELY DISCONNECT FROM MAINS AND CONTACT THE NEAREST SERVICING CENTRE.



THIS APPLIANCE IS MARKED ACCORDING TO THE EUROPEAN DIRECTIVE 2002/96/EC ON WASTE ELECTRICAL AND ELECTRONIC EQUIPMENT (WEEE). THIS GUIDELINE IS THE FRAME OF A EUROPEAN-WIDE VALIDITY OF RETURN AND RECYCLING ON WASTE ELECTRICAL AND ELECTRONIC EQUIPMENT.



BEFORE THE APPLIANCE IS PUT INTO OPERATION, ALL THE LABELS AND PROTECTIVE FILMS APPLIED INSIDE OR OUTSIDE MUST BE REMOVED.



The manufacturer declines all responsibility for damage to persons or things caused by non-observance of the above prescriptions or by interference with any part of the appliance or by the use of non-original spares.

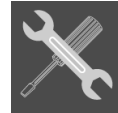

2 INSTALLATION OF THE APPLIANCE



*It is the law that all appliances are installed by **competent persons**.*

This appliance may be installed next to a wall which is higher than the appliance, with a minimum distance of 50 mm from the side of the appliance, as shown in the diagram showing the correct installation conditions. Any wall cupboards or shelves must be at a distance of at least 750 mm above the work surface.

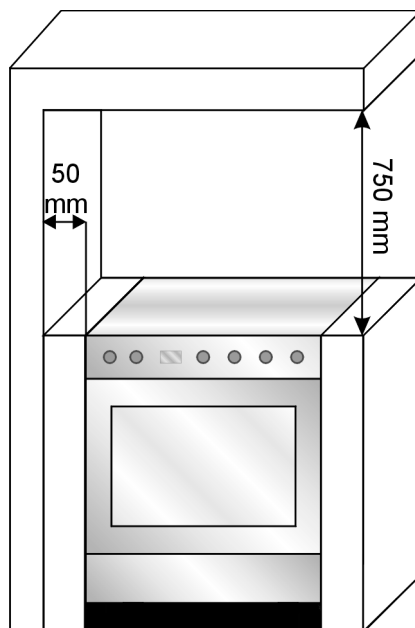



Instructions for the installer

GB-IE

2.1 Electrical connection

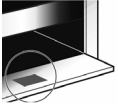

Make sure that the power line voltage matches the specifications indicated on the rating plate located inside the storage compartment.

This rating plate must never be removed.



If the appliance is connected to the supply by means of a fixed connection, install a multipolar cut-out device on the line, with contact opening distance equal to or greater than **3 mm**, located near the appliance and in an easily reachable position.

The connection terminals are located at the rear of the appliance. For electrical connections see following diagram. To access, remove the rear cover.

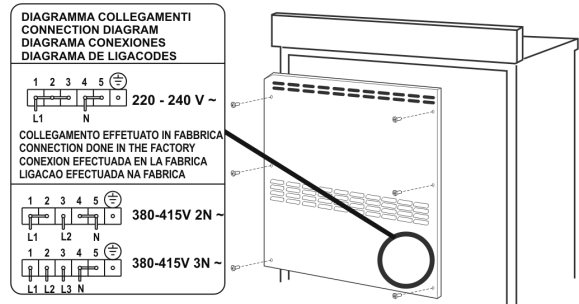

For operation on 380-415V3N~: use an H05RR-F / H05RN-F / H05V2V2-F type five-core cable (5 x 1.5 mm²).

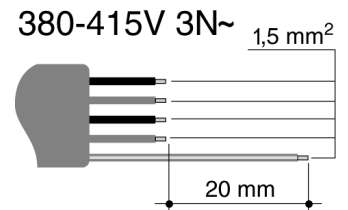

For operation on 380-415V2N~: use an H05RR-F / H05RN-F / H05V2V2-F type five-core cable (cavo di 4 x 2.5 mm²).

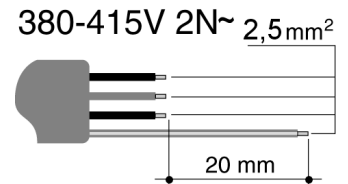

For operation on 220-240V~: use an H05RR-F / H05RN-F / H05V2V2-F (cavo di 3 x 4 mm²).

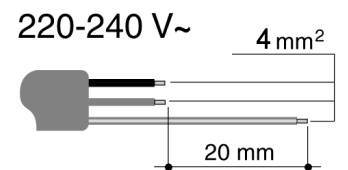

The cable end to be connected to the appliance must be provided with an ground wire (yellow-green) at least 20 mm longer.

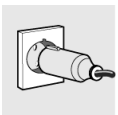

Complete wiring up to power supply with an appropriately rated five-core plug (see data plate) or, in case of operation from a **220-240V~** power supply, with a three-core plug. Make sure that plug and wall socket are of the same type and are in conformity with regulations in force. Make sure that the appliance is properly earthed. Before powering, check that the power line is properly earthed. Avoid using adapters or shunters.



The manufacturer declines all responsibility for damage to persons or things caused by non-observance of the above prescriptions or by interference with any part of the appliance.



2.2 Wall fixing

- Stretch out the chain attached to the cooker horizontally so that the other end touches the wall.
- Mark the wall in the position where the hole is to be drilled.
- Drill the hole, insert the finned dowels and attach the chain.
- Move the cooker up against the wall.

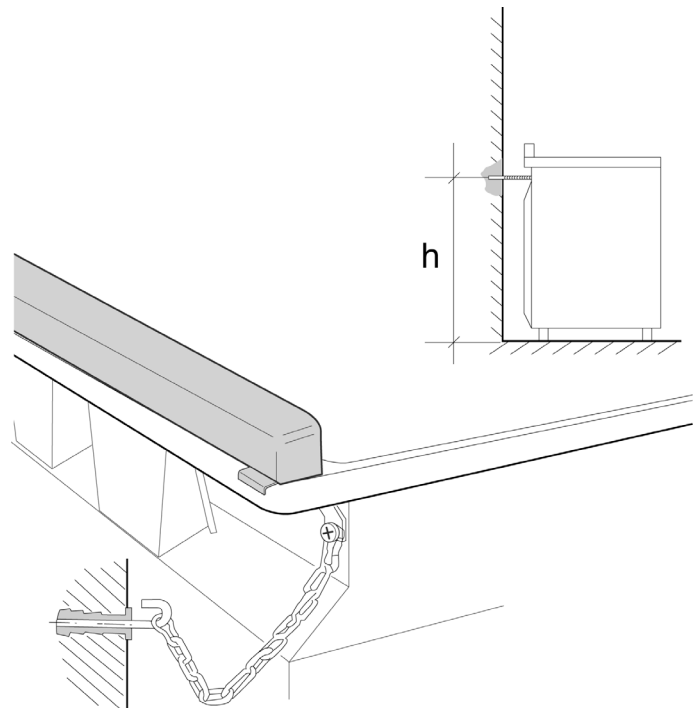



Instructions for the user

GB-IE

3 DESCRIPTION OF CONTROLS

All the cooker controls and commands are on the front panel.



FRONT RIGHT-HAND COOKING ZONE



OVEN THERMOSTAT



REAR RIGHT-HAND COOKING ZONE



OVEN FUNCTIONS



REAR LEFT-HAND COOKING ZONE



VARIABLE GRILL



FRONT LEFT-HAND COOKING ZONE



Before using the oven check that the electronic programmer is showing the symbol ; see paragraph "6.1 Clock adjustment".

COOKING HOB CONTROL KNOB

Standard heating

The circle next to each knob indicates the cooking zone it controls. To heat, turn the knob to the desired position. Adjustment is continuous so that the appliance also operates at any intermediate value. To turn off, return the knob to 0.



Double heating

The circle next to each knob indicates the cooking zone it controls. To heat the inner cooking zone, turn the knob to the desired position.

To heat both the inner and outer cooking zones, turn the knob to / ; and then release. The knob will thus return to 9. To adjust heating intensity, rotate the knob anticlockwise to the desired position. To return to heating of the inner cooking zone only, set the knob back to and then turn to the desired position. To switch off, return knob to 0.



Instructions for the user



ELECTRIC OVEN THERMOSTAT KNOB

Selection of cooking temperature is carried out by turning the knob clockwise to the required temperature, between **50°** and **260°C**.

If the appliance has an electric oven, the warning light will come on when the oven is heating up. When it goes out it means that the required temperature has been reached. Regular flashing means that oven temperature is being constantly maintained at the programmed level.

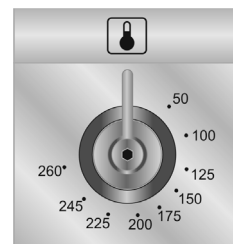

VARIABLE GRILL KNOB

This allows to vary heat intensity when cooking with the grill. The knob can be set with continuity between "0" and the stop release position, which corresponds to maximum heat.

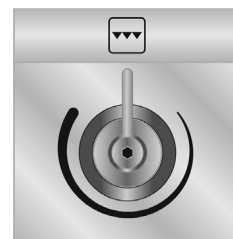

ELECTRIC OVEN CONTROL KNOB

Each of the functions listed below can be used (except the oven light and the small grill) only together with the correct temperature thermostat regulation as described on page 10 of this manual.

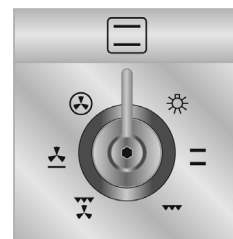

OVEN LIGHT



GRILL ELEMENT + VENTILATION



UPPER AND LOWER HEATING ELEMENT



LOWER HEATING ELEMENT + VENTILATION



GRILL ELEMENT



VENTILATED HEATING ELEMENT + VENTILATION

THERMOSTAT INDICATOR LIGHT (ORANGE)

When this light comes on, the oven is heating up.
 When this light goes out, the preset heating temperature has been reached.
 When the light flashes, the temperature inside the oven is steady at the set temperature.

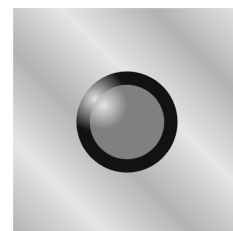

VARIABLE GRILL INDICATOR LIGHT (RED)

When this light comes on, the oven is heating up.
 When this light goes out, the preset heating temperature has been reached.
 When the light flashes, the temperature inside the oven is steady at the set temperature.

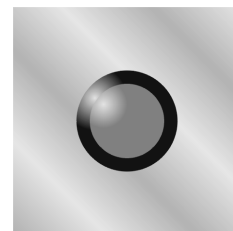



Instructions for the user

GB-IE

4 USE OF THE COOKING HOB

4.1 Cooking zones

The appliance features 4/5 cooking zones of different diameter and power. Their position is clearly indicated by circles and the heat given off is defined by the markings on the glass surface. The 5 cooking zones are of the HIGH-LIGHT type and come on after a few seconds of being activated. Heating intensity can be adjusted by means of the knobs located on the front panel from a minimum to a maximum.

The cooking zones marked by two concentric circles (⊙) and by a circle + fish-kettle (☉) feature double heating either within the inner circle or both circles.

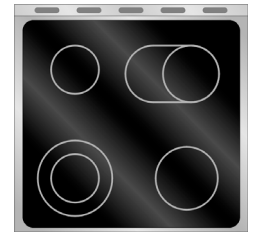

The 4/5 signal lamps located between the cooking zones come on when the temperature of one or more of the heating zones exceeds 60°C. The lamps go off upon temperature dropping to below approximately 60°C.



When using for the first time, it is advisable to heat up the cooking hob to its maximum temperature for enough time so as to burn off any possible oily manufacturing residues, the smell of which could otherwise be absorbed by the food.

For best results and energy saving, only use receptacles suitable for electric cooking:

- The bottom of the receptacles must be very thick and perfectly flat; before placing on the cooking hob, make sure that it, as well as the cooking hob itself, are perfectly clean and dry.
- To avoid scratching of the cooking hob, never use cast-iron receptacles or receptacles with a rough bottom.
- To avoid waste of energy, make sure that the diameter of the receptacle bottom is the same as that of the circle marked on the cooking hob.

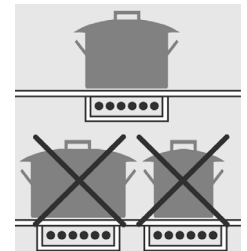

*Take care not to spill sugar or sweet mixtures on to the cooking hob when hot. Never place materials or substances which may melt (plastic or aluminium foil) on to the cooking hob. In the event, promptly switch off and remove the molten material with the scraper provided while the top is still warm to prevent it from being damaged. **Failure to instantly clean the glazed ceramic hob could lead to encrustations which are impossible to remove once the hob has cooled down.***

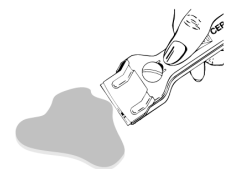

Important.

Beware of children in the vicinity as the signal lamps indicating residual heat are out of sight to them. In fact, even after having been turned off, the cooking hob remains hot for a certain period of time.

Make sure that children never touch the cooking hob.



5 USE OF THE OVEN



For those models with electronic programmer, before using the oven make sure that the display shows the symbol .

For those models with analogue clock and timer, place on the symbol .

5.1 Warnings and general advice

Before using the oven for the first time, pre-heat it to maximum temperature (250°C) long enough to burn any manufacturing oily residues which could give the food a bad taste.

After a power failure, the display will flash at regular intervals showing . To regulate, refer to paragraph "6 ELECTRONIC PROGRAMMER".



Oven accessories which may come into contact with foods are made from materials complying with the requirements of the current directive.





During cooking, do not cover the bottom of the oven with aluminium or tin foil and do not place pans or oven trays on it as this may damage the enamel coating. If you wish to use greaseproof paper, place it so that it will not interfere with the hot air circulation inside the oven.

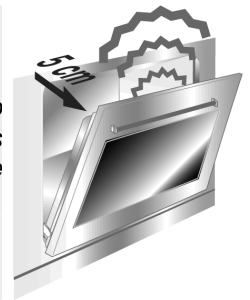

To prevent any steam in the oven creating problems, open the door in two stages: half open (5 cm approx.) for 4-5 seconds and then fully open. To access food, always leave the door open as short a time as possible to prevent the temperature in the oven from falling and ruining the food.



5.2 Use of the electric grill

For short cooking times, for example for browning already-cooked meat, select the static grill function ; set the thermostat knob to maximum temperature (260°C) and adjust grill intensity by means of the variable grill knob without exceeding the $\frac{3}{4}$ stroke as shown in the figure. The ventilated grill function allows actual cooking to be done, thanks to the forced ventilation which lets heat penetrate inside the food. For this type of cooking select the ventilated grill function , set the thermostat knob to the desired cooking temperature (never more than 220°C). Cooking time must not exceed 60 minutes.





Instructions for the user

How to use the grill

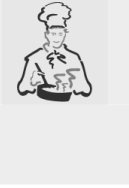

Once the grill is lit, the red warning light will come on. Leave the oven to heat up for five minutes before placing the food inside.

Food should be flavoured and basted with oil or melted butter before cooking. An oven dish should be used to contain the sauces.

The food should be placed on the oven shelf which is positioned on one of the guides supplied with the different ovens, following the instructions below:

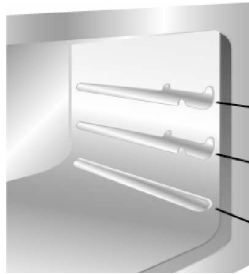
	FOOD	GRILLE ON THE SHELF
	Flat or thin meat	3
	Rolled roast joints	2 – 3
	Poultry	2 – 3

WARNINGS

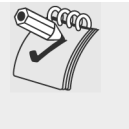

- **Cooking procedures in this mode must never last more than 60 minutes.**
- **The door must be close during grilling and grill-rotisserie cooking.**
- **During and after use the accessible parts of the oven may be very hot, and children must always be kept at a distance.**

5.3 Storage compartment

A storage compartment, accessible by pulling on the top edge of the door, is located beneath the oven.

Never store flammable materials such as rags, paper or the like. The compartment is intended only for holding the metal accessories of the range.







Never open the storage compartment when the oven is on and still hot. The temperature inside may be very high.





6 ELECTRONIC PROGRAMMER (ONLY ON EQUIPPED MODELS)



LIST OF FUNCTIONS

	MINUTE-COUNTER KEY
	COOKING TIME KEY
	END-OF-COOKING KEY
	DECREASE TIME KEY
	INCREASE TIME KEY

6.1 Clock adjustment

When using the oven for the first time, or after a power failure, the display flashes regularly and indicates **0:00**. Press the keys   and at the same time the keys **+** or **-**: each single press changes the time by 1 minute either up or down.





Before setting the programmer activate the desired function and temperature.

6.2 Semiautomatic cooking

Use this setting for automatic oven switch-off at the end of cooking time.

By pressing key , the display lights up, showing **0:00**; keep the key pressed and at the same time, press keys **-** or **+** to set the cooking time.



Release key  to start the programmed cooking time count. The display will now show the right time together with symbols **A** and .





6.3 Automatic cooking

Use this setting to automatically start and stop the oven.

By pressing key , the display lights up showing **0:00**; keep the key pressed and at the same time, press keys **-** or **+** to set the cooking time.

By pressing key  the sum of the right time + cooking time will appear; keep the key pressed and at the same time, press keys **-** or **+** to regulate the end of cooking time. Release key  to start the programmed count and the display will show the right time together with symbols **A** and .



After set-up, to see the cooking time remaining, press the key ; to see the end of cooking time press the key . Set-up with incoherent values is logically prevented (e.g. the contrast between a cooking time and a longer period will not be accepted by the programmer).



Instructions for the user

6.4 End of cooking



When cooking is over, the oven will automatically switch off and, at the same time, an intermittent alarm will sound. After switching off the alarm, the display will once again show the right time together with the symbol , indicating that the oven has returned to manual operation mode.









6.5 Adjusting alarm volume

The acoustic alarm has three different settings. These can be operated, while the alarm is sounding, by pressing key .

6.6 Switching off the alarm

The alarm switches off automatically after seven minutes. They can be manually de-activated by pressing the keys  and  together.



6.7 Minute Counter

The programmer can also be used as a simple minute counter. By pressing key , the display shows ; keep the key pressed and at the same time press keys  or . On releasing the key , programmed counting will begin and the display will show the current time and the symbol .





*After set-up, to see the remaining time, press the key .
Use as a minute counter does not interrupt functioning of the oven at the end of the programmed time.*

6.8 Cancellation of set data

Once the programme has been set, keep the key of the function to be cancelled pressed, while at the same time  is reached by means of variation keys  or . Time cancellation will be considered as end-of-cooking time by the programmer.

6.9 Changing the set data

The cooking data entered can be changed at any time by keeping the function key pressed and at the same time adjusting the keys  or .



7 CLEANING AND MAINTENANCE

7.1 Cleaning stainless steel and enamelled versions



To maintain stainless steel in good condition it must be cleaned regularly after each use, once it has cooled down.

7.1.1 Ordinary Daily Cleaning

To clean and preserve the stainless steel surfaces, always use **only** specific products that do not contain abrasives or chlorine-based acids.

How to use: pour the product on a damp cloth and wipe the surface, rinse thoroughly and dry with a soft cloth or deerskin.

7.1.2 Food stains or residues

Do not use metallic sponges or sharp scrapers: they will damage the surface.

Use normal non-abrasive products for steel, and a wooden or plastic tool if necessary.

Rinse thoroughly and dry with a soft cloth or deerskin.

Do not allow residues of sugary foods (such as jam) to set inside the oven. If left to set for too long, they might damage the enamel lining of the oven.



7.2 Cleaning the glazed ceramic hob



Before any intervention, disconnect the power supply of the device



The cooking hob should be regularly cleaned; best after every use, once the residual heat signal lamps have gone off.

Smudges from aluminium-bottom pans can be easily cleaned off with a cloth dampened in vinegar.

Remove any burnt residues after cooking with the scraper provided; rinse with water and wipe dry with a clean cloth. Regular use of the scraper considerably reduces the need for chemical detergents for the daily cleaning of the hob. Never use abrasive or corrosive detergents (e.g. cleaning powders, oven sprays, spot-removers, wire sponges).

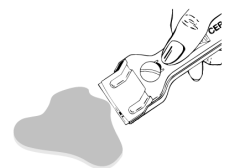



Instructions for the user

GB-IE

7.3 Cleaning of oven



For best oven upkeep clean regularly after having allowed to cool. Take out all removable parts.

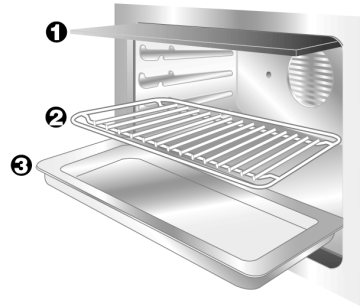
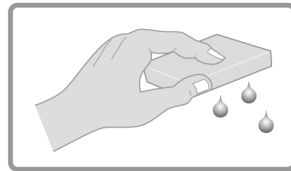

- Clean the oven grill with hot water and non-abrasive detergent. Rinse and dry.
- Clean the internal walls of the oven with a soft ammoniac-soaked cloth. Rinse and dry. If there are still stains or drops, place a damp ammoniac-soaked cloth on the bottom of the oven, close the door and after a few hours wash the oven with hot water and liquid detergent. Rinse and dry.

7.4 Door glass

The door glass should always be kept clean. Use absorbent kitchen paper to clean. In case of tough spots, clean with a damp sponge using regular detergent.



8 EXTRAORDINARY MAINTENANCE

The oven may require extraordinary maintenance or replacement of parts subject to wear such as seals, bulbs, and so on. The following instructions describe how to carry out these minor maintenance operations.



Before any intervention, disconnect the power supply of the device.

8.1 Lubrication of the taps and gas oven thermostat



In time the taps and gas oven thermostat may be difficult to turn or may be blocked. Clean them inside and replace the lubrication grease. **This operation should be carried out by a specialised technician.**

8.2 Replacement of light bulb

Remove cover **A** by twisting anticlockwise, replace bulb **B** with another similar bulb (25 W). Refit the cover **A**.

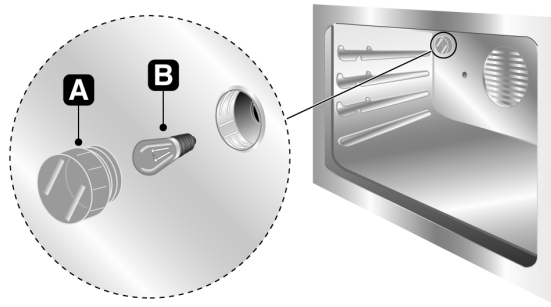

Only use oven bulbs (T 300°C).

8.3 Removing the door

Raise levers **B** and hold the door on both sides with both hands near hinges **A** and. Lift up the door forming an angle of about 45° and remove. To refit, slide the hinges **A** in the grooves, drop the door and release levers **B**.

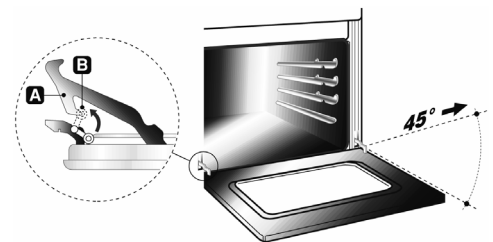

8.4 Oven door seal

To permit thorough cleaning of the oven, the seal may be removed. Before removing the seal, take off the door as described above. Once the door has been taken off, lift the tabs at the corners as shown in the figure.

