

SHARP SERVICE MANUAL

S8123R1500X//

OVER THE RANGE MICROWAVE OVEN

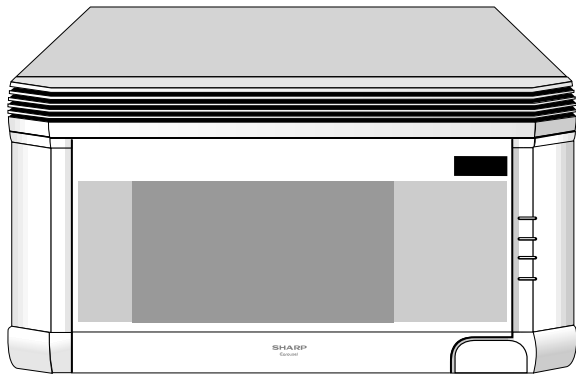

MODELS **R-1500**
R-1501
R-1505
R-1506

In the interest of user-safety the oven should be restored to its original condition and only parts identical to those specified should be used.

WARNING TO SERVICE PERSONNEL: Microwave ovens contain circuitry capable of producing very high voltage and current. Contact with the following parts may result in a severe, possibly fatal, electrical shock. (High Voltage Capacitor, High Voltage Power Transformer, Magnetron, High Voltage Rectifier Assembly, High Voltage Harness etc..)

TABLE OF CONTENTS

	Page
PRECAUTIONS TO BE OBSERVED BEFORE AND DURING SERVICING TO AVOID POSSIBLE EXPOSURE TO EXCESSIVE MICROWAVE ENERGY	INSIDE FRONT COVER
BEFORE SERVICING	INSIDE FRONT COVER
WARNING TO SERVICE PERSONNEL	1
MICROWAVE MEASUREMENT PROCEDURE	2
FOREWORD AND WARNING	3
PRODUCT SPECIFICATIONS	4
GENERAL INFORMATION	4
OPERATION	7
TROUBLESHOOTING GUIDE	11
TEST PROCEDURE	13
TOUCH CONTROL PANEL ASSEMBLY	21
COMPONENT REPLACEMENT AND ADJUSTMENT PROCEDURE	25
PICTORIAL DIAGRAM	33
POWER UNIT CIRCUIT	34
LSI UNIT CIRCUIT	35
PRINTED WIRING BOARD	36
PARTS LIST	37
PACKING AND ACCESSORIES	39

SHARP CORPORATION

This document has been published to be used for after sales service only.

The contents are subject to change without notice.

PRECAUTIONS TO BE OBSERVED BEFORE AND DURING SERVICING TO AVOID POSSIBLE EXPOSURE TO EXCESSIVE MICROWAVE ENERGY

- (a) Do not operate or allow the oven to be operated with the door open.
- (b) Make the following safety checks on all ovens to be serviced before activating the magnetron or other microwave source, and make repairs as necessary: (1) interlock operation, (2) proper door closing, (3) seal and sealing surfaces (arcing, wear, and other damage), (4) damage to or loosening of hinges and latches, (5) evidence of dropping or abuse.
- (c) Before turning on microwave power for any service test or inspection within the microwave generating compartments, check the magnetron, wave guide or transmission line, and cavity for proper alignment, integrity, and connections.
- (d) Any defective or misadjusted components in the interlock, monitor, door seal, and microwave generation and transmission systems shall be repaired, replaced, or adjusted by procedures described in this manual before the oven is released to the owner.
- (e) A microwave leakage check to verify compliance with the Federal Performance Standard should be performed on each oven prior to release to the owner.

BEFORE SERVICING

Before servicing an operative unit, perform a microwave emission check as per the Microwave Measurement Procedure outlined in this service manual.

If microwave emissions level is in excess of the specified limit, contact SHARP ELECTRONICS CORPORATION immediately @1-800-237-4277.

If the unit operates with the door open, service person should 1) tell the user not to operate the oven and 2) contact SHARP ELECTRONICS CORPORATION and Food and Drug Administration's Center for Devices and Radiological Health immediately.

Service personnel should inform SHARP ELECTRONICS CORPORATION of any certified unit found with emissions in excess of $4\text{mW}/\text{cm}^2$. The owner of the unit should be instructed not to use the unit until the oven has been brought into compliance.

WARNING TO SERVICE PERSONNEL

Microwave ovens contain circuitry capable of producing very high voltage and current, contact with following parts may result in a severe, possibly fatal, electrical shock.

(Example)

High Voltage Capacitor, High Voltage Power Transformer, Magnetron, High Voltage Rectifier Assembly, High Voltage Harness etc..

Read the Service Manual carefully and follow all instructions.

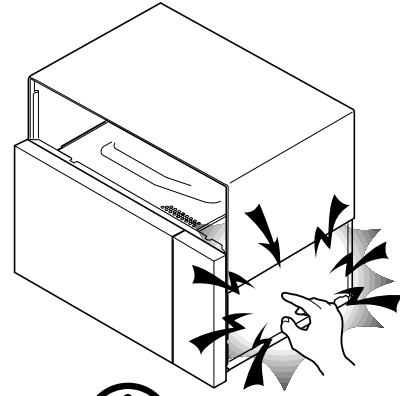

**Don't Touch !
Danger High Voltage**

Before Servicing



1. Disconnect the power supply cord , and then remove outer case.
2. Open the door and block it open.
3. Discharge high voltage capacitor.

**WARNING: RISK OF ELECTRIC SHOCK.
DISCHARGE THE HIGH-VOLTAGE
CAPACITOR BEFORE SERVICING.**

The high-voltage capacitor remains charged about 60 seconds after the oven has been switched off. Wait for 60 seconds and then short-circuit the connection of the high-voltage capacitor (that is the connecting lead of the high-voltage rectifier) against the chassis with the use of an insulated screwdriver.

Whenever troubleshooting is performed the power supply must be disconnected. It may, in some cases, be necessary to connect the power supply after the outer case has been removed, in this event,

1. Disconnect the power supply cord, and then remove outer case.
2. Open the door and block it open.
3. Discharge high voltage capacitor.
4. Disconnect the leads to the primary of the power transformer.
5. Ensure that these leads remain isolated from other components and oven chassis by using insulation tape.
6. After that procedure, reconnect the power supply cord.

When the testing is completed,

1. Disconnect the power supply cord, and then remove outer case.
2. Open the door and block it open.
3. Discharge high voltage capacitor.
4. Reconnect the leads to the primary of the power transformer.
5. Reinstall the outer case (cabinet).
6. Reconnect the power supply cord after the outer case is installed.
7. Run the oven and check all functions.

After repairing

1. Reconnect all leads removed from components during testing.
2. Reinstall the outer case (cabinet).
3. Reconnect the power supply cord after the outer case is installed.
4. Run the oven and check all functions.

Microwave ovens should not be run empty. To test for the presence of microwave energy within a cavity, place a cup of cold water on the oven turntable, close the door and set the power to HIGH and set the microwave timer for two (2) minutes. When the two minutes has elapsed (timer at zero) carefully check that the water is now hot. If the water remains cold carry out **Before Servicing** procedure and re-examine the connections to the component being tested.

When all service work is completed and the oven is fully assembled, the microwave power output should be checked and microwave leakage test should be carried out.

MICROWAVE MEASUREMENT PROCEDURE

A. Requirements:

- 1) Microwave leakage limit (Power density limit): The power density of microwave radiation emitted by a microwave oven should not exceed 1 mW/cm^2 at any point 5cm or more from the external surface of the oven, measured prior to acquisition by a purchaser, and thereafter (through the useful life of the oven), 5 mW/cm^2 at any point 5cm or more from the external surface of the oven.
- 2) Safety interlock switches: Primary interlock switch shall prevent microwave radiation emission in excess of the requirement as above mentioned, secondary interlock relay and door sensing switch shall prevent microwave radiation emission in excess of 5 mW/cm^2 at any point 5cm or more from the external surface of the oven.

B. Preparation for testing:

Before beginning the actual measurement of leakage, proceed as follows:

- 1) Make sure that the actual instrument is operating normally as specified in its instruction booklet.

Important:

Survey instruments that comply with the requirement for instrumentation as prescribed by the performance standard for microwave ovens, 21 CFR 1030.10(c)(3)(i), must be used for testing.

- 2) Place the oven tray in the oven cavity.
- 3) Place the load of $275\pm 15\text{ ml}$ (9.8 oz) of tap water initially at $20\pm 5^\circ\text{C}$ (68°F) in the center of the oven cavity. The water container shall be a low form of 600 ml (20 oz) beaker with an inside diameter of approx. 8.5 cm (3-1/2 in.) and made of an electrically nonconductive material such as glass or plastic. The placing of this standard load in the oven is important not only to protect the oven, but also to insure that any leakage is measured accurately.
- 4) Set the cooking control on Full Power Cooking Mode
- 5) Close the door and select a cook cycle of several minutes. If the water begins to boil before the survey is completed, replace it with 275 ml of cool water.

C. Leakage test:

Closed-door leakage test (microwave measurement)

- 1) Grasp the probe of the survey instrument and hold it perpendicular to the gap between the door and the body of the oven.
- 2) Move the probe slowly, not faster than 1 in./sec. (2.5 cm/sec.) along the gap, watching for the maximum indication on the meter.
- 3) Check for leakage at the door screen, sheet metal seams and other accessible positions where the continuity of the metal has been breached (eg., around the switches, indicator, and vents). While testing for leakage around the door pull the door away from the front of the oven as far as is permitted by the closed latch assembly.
- 4) Measure carefully at the point of highest leakage and make sure that the highest leakage is no greater than 4 mW/cm^2 , and that the primary interlock switch does turn the oven OFF before any door movement.

NOTE: After servicing, record data on service invoice and microwave leakage report.

SERVICE MANUAL

SHARP

OVER THE RANGE MICROWAVE OVEN

R-1500/ R-1501/ R-1505/ R-1506

FOREWORD

This Manual has been prepared to provide Sharp Electronics Corp. Service Personnel with Operation and Service Information for the SHARP OVER THE RANGE MICROWAVE OVEN, R-1500, R-1501 R-1505 and R-1506.

It is recommended that service personnel carefully study the entire text of this manual so that they will be qualified to render satisfactory customer service.

Check the interlock switches and the door seal carefully. Special attention should be given to avoid electrical shock and microwave radiation hazard.

WARNING

Never operate the oven until the following points are ensured.

- (A) The door is tightly closed.
- (B) The door brackets and hinges are not defective.
- (C) The door packing is not damaged.
- (D) The door is not deformed or warped.
- (E) There is not any other visible damage with the oven.

Servicing and repair work must be carried out only by trained service personnel.

DANGER

**Certain internal parts are intentionally not grounded and present a risk of electrical shock only during servicing. Service personnel - Do not contact the following parts while the appliance is energized;
High Voltage Capacitor, Power Transformer, Magnetron, High Voltage Rectifier Assembly, High Voltage Harness;
If provided, Vent Hood, Fan assembly, Cooling Fan Motor.**

All the parts marked "*" on parts list are used at voltages more than 250V.

Removal of the outer wrap gives access to voltage above 250V.

All the parts marked "Δ" on parts list may cause undue microwave exposure, by themselves, or when they are damaged, loosened or removed.

SHARP ELECTRONICS CORPORATION

SHARP PLAZA, MAHWAH,
NEW JERSEY 07430-2135

PRODUCT DESCRIPTION

GENERAL INFORMATION

OPERATION

TROUBLESHOOTING GUIDE AND
TEST PROCEDURE

TOUCH CONTROL PANEL

COMPONENT REPLACEMENT
AND ADJUSTMENT PROCEDURE

WIRING DIAGRAM

PARTS LIST

PRODUCT SPECIFICATION

ITEM	DESCRIPTION
Power Requirements	120 Volts / 14 Amperes 60 Hertz Single phase, 3 wire grounded
Power Output	1000 watts (IEC TEST PROCEDURE) Operating frequency of 2450MHz
Case Dimensions	Width 29-15/16" Height 16-1/4" Depth 15- 9/16"
Cooking Cavity Dimensions 1.5 Cubic Feet	Width 17-1/2" Height 9-7/8" Depth 14-15/16"
Hood lamp	2 bulbs, 20W x 2, Incandescent light bulbs
Hood fan	Approx. 300 C.F.M.
Control Complement	Touch Control System Clock (1:00 - 12:59) Timer (0 - 99 min. 99 seconds) Microwave Power for Variable Cooking Repetition Rate; P-HI Full power throughout the cooking time P-90 approx. 90% of Full Power P-80 approx. 80% of Full Power P-70 approx. 70% of Full Power P-60 approx. 60% of Full Power P-50 approx. 50% of Full Power P-40 approx. 40% of Full Power P-30 approx. 30% of Full Power P-20 approx. 20% of Full Power P-10 approx. 10% of Full Power P-0 No power throughout the cooking time KEEP WARM pad, POPCORN pad, HOT WATER pad REHEAT CENTER pads, COOK CENTER pads DEFROST CENTER pads, Number selection pads POWER LEVEL pad, TIMER / CLOCK pad LIGHT HI / LO button, FAN HI / LO button, STOP/CLEAR button, START/ MINUTE PLUS button,
Oven Cavity Light	20W x 1 Incandescent light bulb
Safety Standard	UL Listed FCC Authorized DHHS Rules, CFR, Title 21, Chapter 1, Subchapter J
Weight	Approx. 55 lbs.

GENERAL INFORMATION

GROUNDING INSTRUCTIONS

This oven is equipped with a three prong grounding plug. It must be plugged into a wall receptacle that is properly installed and grounded in accordance with the National Electrical Code and local codes and ordinances.

In the event of an electrical short circuit, grounding reduces the risk of electric shock by providing an escape wire for the electric current.

WARNING: Improper use of the grounding plug can result in a risk of electric shock.

Electrical Requirements

The oven is equipped with a 3-prong grounding plug. **DO NOT UNDER ANY CIRCUMSTANCES CUT OR REMOVE THE GROUNDING PIN FROM THE PLUG.**

The power supply cord and plug must be connected to a separate 120 Volt AC, 60 Hz, 15 Amp. or more dedicated line, using a grounded receptacle. The receptacle should be located inside the cabinet directly above the Microwave Oven/Hood system mounting location.

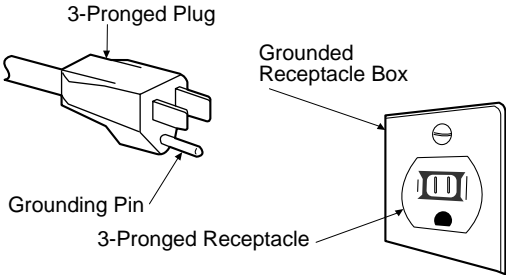
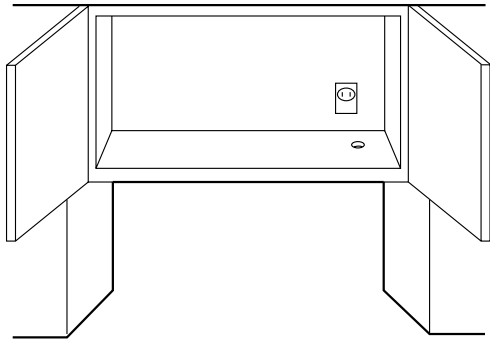

OVEN DIAGRAM

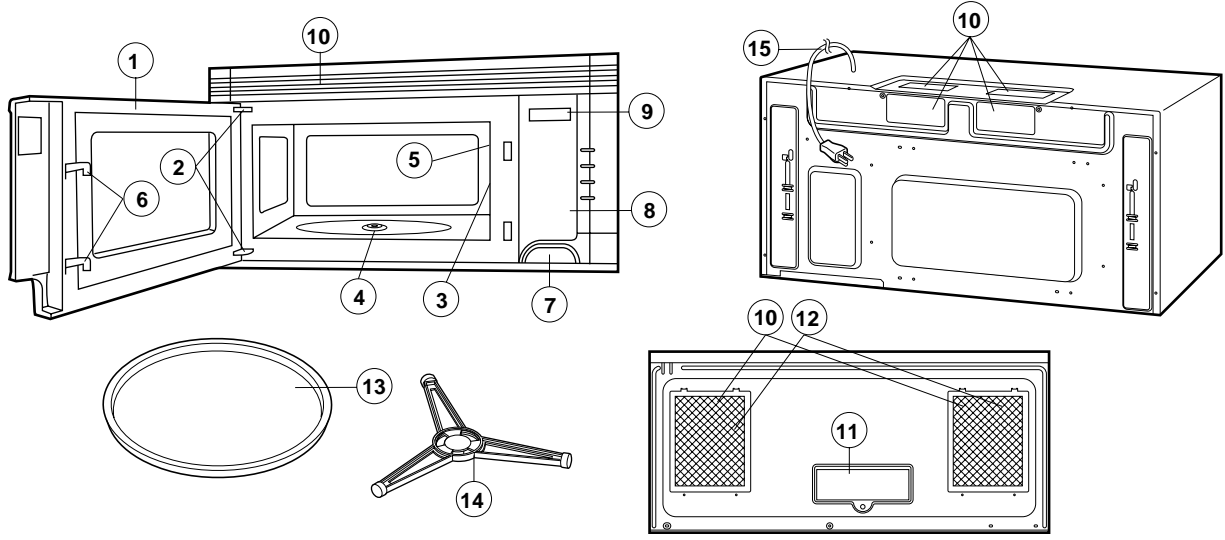

- 1. Oven door with see-through window.
- 2. Door hinges.
- 3. Waveguide cover.
- 4. Turntable motor shaft.
- 5. Oven lamp.
It will light when oven is operating or door is open.
- 6. Door latches.
The oven will not operate unless the door is securely closed.
- 7. One touch door open button.
- 8. Auto Touch control panel
- 9. Time display: Digital display, 99 minutes 99 seconds.
- 10. Ventilation openings.
- 11. Light Cover.
- 12. Grease filters.
- 13. Removable turntable.
The turntable will rotate clockwise or counterclockwise.
Only remove for cleaning.
- 14. Removable turntable support.
- 15. Power supply cord

CONTROL PANEL

1000 WATTS

12:30

COOK DEFROST

NO.
LBS.
CUPS
OZ.

KEEP
WARM

POPCORN

HOT
WATER

REHEAT CENTER

1 Casserole	5 Dinner Plate
2 Soup	6 Fresh Rolls / Muffins
3 Pizza	7 Frozen Rolls / Muffins
4 Beverage	8 Canned Vegetables

COOK CENTER

BAKED POTATOES	RICE
FROZEN VEGETABLES	FRESH VEGETABLES
GROUND MEAT	FROZEN ENTREES

DEFROST CENTER

GROUND MEAT	STEAKS/ CHOPS
POULTRY BONELESS	POULTRY BONE-IN

1

2

3

4

5

6

7

8

9

POWER
LEVEL

0

TIMER
CLOCK

LIGHT HI/ LO



FAN HI/ LO



STOP
CLEAR



START
MINUTE PLUS



NOTE: Some one-touch cooking features such as "MINUTE PLUS" are disabled after three minutes when the oven is not used. These features are automatically enabled when the door is opened and closed or STOP/CLEAR button is pressed.

OPERATION

DESCRIPTION OF OPERATING SEQUENCE

The following is a description of component functions during oven operation.

OFF CONDITION

Closing the door activates the door sensing switch and primary interlock switch. (In this condition, the monitor switch contacts are opened.)

When oven is plugged in, 120 volts A.C. is supplied to the control unit. (Figure O-1).

- The display will show flashing "88 : 88".
To set any program or set the clock, you must first touch the STOP/CLEAR button. The display will clear, and " : " will appear .

COOKING CONDITION

Program desired cooking time touching the NUMBER pads. When the START button is touched, the following operations occur:

- The contacts of relays are closed and components connected to the relays are turned on as follows.
(For details, refer to Figure O-2)

RELAY	CONNECTED COMPONENTS
RY1	Oven lamp / Fan motor / Turntable motor
RY2	Power transformer
RY3, RY4	Hood fan motor
RY5, RY6	Hood lamp

- 120 volts A.C. is supplied to the primary winding of the power transformer and is converted to about 3.3 volts A.C. output on the filament winding, and approximately 2000 volts A.C. on the high voltage winding.
- The filament winding voltage heats the magnetron filament and the H.V. winding voltage is sent to a voltage doubler circuit.
- The microwave energy produced by the magnetron is channelled through the waveguide into the cavity feed-box, and then into the cavity where the food is placed to be cooked.
- Upon completion of the cooking time, the power transformer, oven lamp, etc. are turned off, and the generation of microwave energy is stopped. The oven will revert to the OFF condition.
- When the door is opened during a cook cycle, monitor switch, door sensing switch, primary interlock switch, relay (RY1) and secondary interlock relay (RY2) are activated with the following results. The circuits to the cooling fan motor, the turntable motor, and the high voltage components are de-energized, the oven lamp remains on, and the digital read-out displays the time still remaining in the cook cycle when the door was opened.
- The monitor switch is electrically monitoring the operation of the primary interlock switch and secondary interlock

relay (RY2) and is mechanically associated with the door so that it will function in the following sequence.

- When the door opens from a closed position, the secondary interlock relay (RY2) and primary interlock switch open their contacts. And contacts of the relay (RY1) remains closed. Then the monitor switch contacts close.
- When the door is closed from the open position, the monitor switch contacts first open, and then the contacts of the primary interlock switch and door sensing switch close. And contacts of the relay (RY1) open.

If the primary interlock switch and secondary interlock relay (RY2) fail with their contacts closed when the door is opened, the closing of the monitor switch contacts will form a short circuit through the monitor fuse, primary interlock switch, relay (RY1) and secondary interlock relay (RY2), causing the monitor fuse to blow.

POWER LEVEL P-0 TO P-90 COOKING

When Variable Cooking Power is programmed, the 120 volts A.C. is supplied to the power transformer intermittently through the contacts of relay (RY2) which is operated by the control unit within an interval second time base. Microwave power operation is as follows:

VARI-MODE	ON TIME	OFF TIME
Power 10(P-HI) (100% power)	32 sec.	0 sec.
Power 9(P-90) (approx. 90% power)	30 sec.	2 sec.
Power 8(P-80) (approx. 80% power)	26 sec.	6 sec.
Power 7(P-70) (approx. 70% power)	24 sec.	8 sec.
Power 6(P-60) (approx. 60% power)	22 sec.	10 sec.
Power 5(P-50) (approx. 50% power)	18 sec.	14 sec.
Power 4(P-40) (approx. 40% power)	16 sec.	16 sec.
Power 3(P-30) (approx. 30% power)	12 sec.	20 sec.
Power 2(P-20) (approx. 20% power)	8 sec.	24 sec.
Power 1(P-10) (approx. 10% power)	6 sec.	26 sec.
Power 0(P-0) (0% power)	0 sec.	32 sec.

Note: The ON/OFF time ratio does not correspond with the percentage of microwave power, because approx. 3 seconds are needed for heating of the magnetron filament.

VENTILATION METHODS HOT AIR EXHAUST

1. VERTICAL VENTING

For this venting method, hot air rising from the conventional range below is drawn in by the hood fan motor through the grease filters at the right and left sides of the base cover, up through the right and left sides of the oven cavity, then discharged vertically at rear center top of the oven, into the customer's vent system.

➡ : AIR FLOW

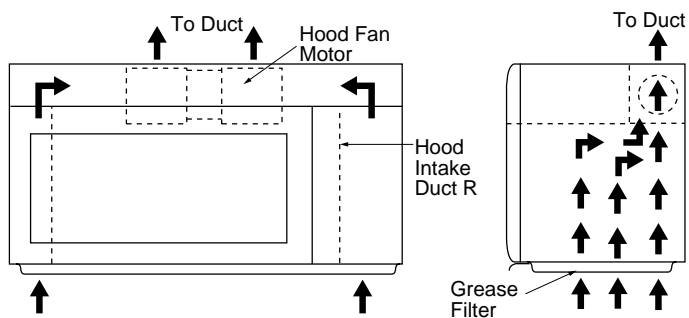

2. HORIZONTAL VENTING

The air handling is the same as VERTICAL VENTING except that the final air discharge is directed horizontally out from the top rear of the oven into the customer's vent system.

➡ : AIR FLOW

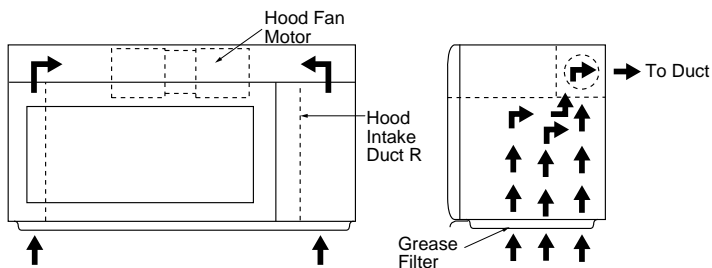

3. RE-CIRCULATION (INSIDE VENTING)

The air handling is the same as VERTICAL VENTING except that the final air discharge is directed horizontally through the upper front of the oven into the kitchen. IN this case, the accessory charcoal filter RK-240 must be provided to filter the air before it leaves the oven.

➡ : AIR FLOW

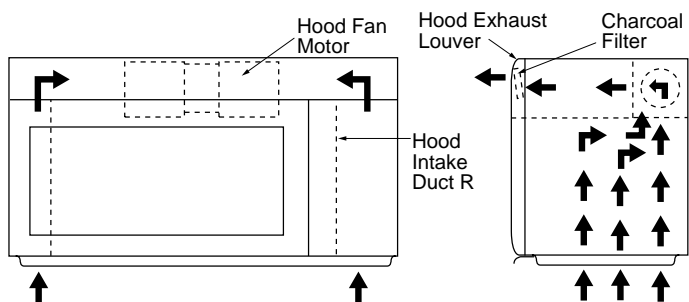

NOTE: "★" indicates components with potential above 250V.

SCHMATIC
NOTE: CONDITION OF OVEN
1. DOOR CLOSED.
2. CLOCK APPEARS ON DISPLAY.

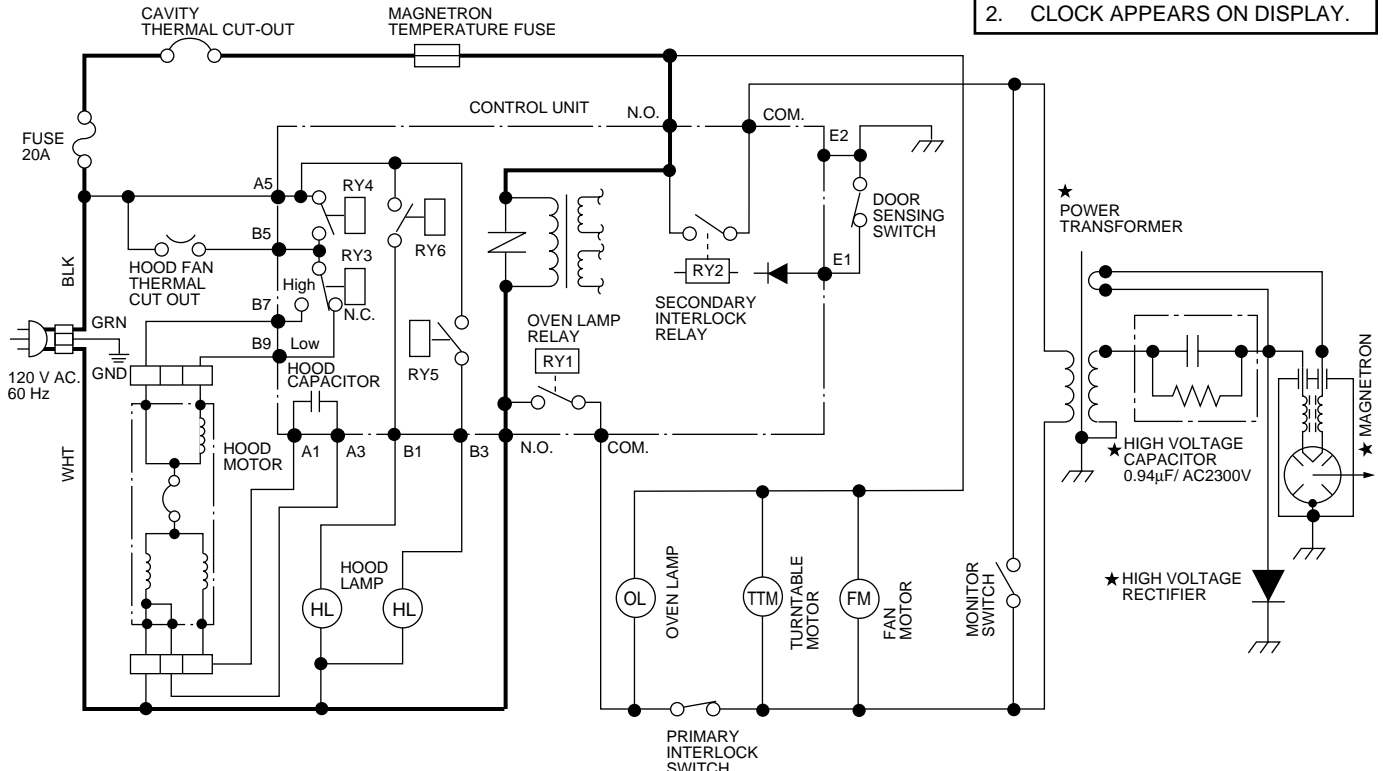

Figure O-1. Oven Schematic-Off Condition

SCHMATIC
NOTE: CONDITION OF OVEN
1. DOOR CLOSED.
2. COOKING TIME PROGRAMMED.
3. VARIABLE COOKING CONTROL "HIGH".
4. "START" BUTTON PRESSED.

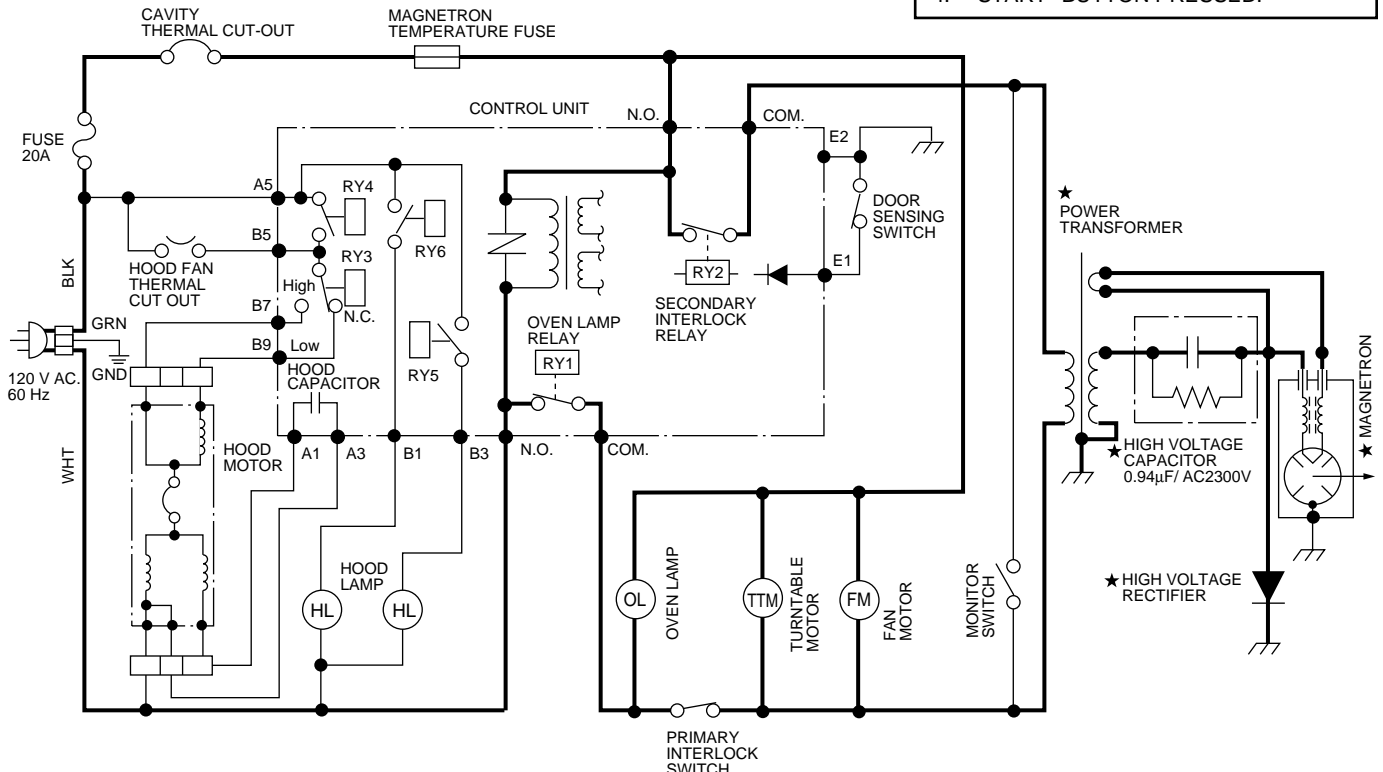

Figure O-2. Oven Schematic-Cooking Condition

DESCRIPTION AND FUNCTION OF COMPONENTS

DOOR OPEN MECHANISM

The door is opened by pushing the open button on the control panel, refer to the Figure D-1.

When the open button is pushed, the open button pushes up the open lever, and then the open lever pushes up the latch head. The latch heads are moved upward and released from latch hook. Now the door will open.

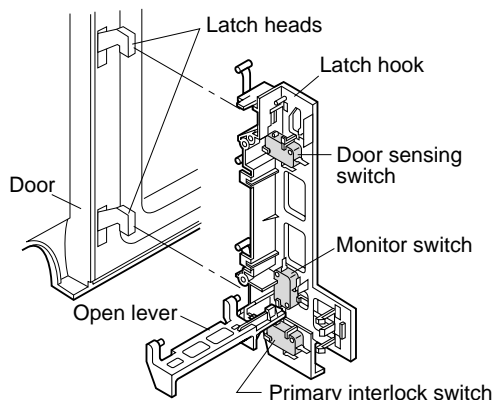

Figure D-1. Door Open Mechanism

DOOR SENSING AND PRIMARY INTERLOCK SWITCHES

The primary interlock switch is mounted in the lower position of the latch hook and the door sensing switch in the secondary interlock system is mounted in the upper position of the latch hook. They are activated by the latch heads on the door. When the door is opened, the switches interrupt the circuit to all components. A cook cycle cannot take place until the door is firmly closed thereby activating both interlock switches. The secondary interlock system consists of the door sensing switch and secondary interlock relay located on the control circuit board.

MONITOR SWITCH

The monitor switch is activated (the contacts opened) by the latch head on the door while the door is closed. The switch is intended to render the oven inoperative by means of blowing the monitor fuse when the contacts of the secondary interlock relay (RY2) and primary interlock switch fail to open when the door is opened.

Functions:

1. When the door is opened, the monitor switch contact close (to the ON condition) due to their being normally closed. At this time the secondary interlock relay (RY2) and primary interlock switch are in the OFF condition (contacts open) due to their being normally open contact switches. And the contacts of relay (RY1) are in the ON condition (contacts close).
2. As the door goes to a closed position, the monitor switch contacts are first opened and then the door sensing switch and the primary interlock switch contacts close. (On opening the door, each of these switches operate inversely.)

3. If the door is opened, and the secondary interlock relay (RY2) and primary interlock switch contacts fail to open, the monitor fuse blows simultaneously with closing of the monitor switch contacts.

CAUTION: BEFORE REPLACING A BLOWN MONITOR FUSE TEST THE DOOR SENSING SWITCH, SECONDARY INTERLOCK RELAY (RY2), RELAY (RY1), PRIMARY INTERLOCK SWITCH AND MONITOR SWITCH FOR PROPER OPERATION. (REFER TO CHAPTER "TEST PROCEDURE").

NOTE: MONITOR FUSE AND SWITCH ARE REPLACED AS AN ASSEMBLY

TEMPERATURE FUSE (MG)

The temperature fuse located on the fan duct assembly is designed to prevent damage to the magnetron if an over heated condition develops in the tube due to cooling fan failure, obstructed air guide, dirty or blocked air intake, etc. Under normal operation, the temperature fuse remains closed. However, the temperature fuse will open at 302°F (150°C) causing the oven to shut down.

NOTE: This is a fuse. It does not reset.

THERMAL CUT-OUT (HOOD)

This thermal cut-out located on the right base plate flange (turntable motor side). It is designed to automatically turn on the hood fan motor whenever the hot air rising from the conventional range below causes the temperature at the thermal cut-out to rise to 140°F (60°C) or higher, thus removing this hot air from around microwave oven. When the temperature around the thermal cut-out drops to 113°F (45°C) or lower, the thermal cut-out shuts off the hood fan motor.

THERMAL CUT-OUT (CAVITY)

This thermal cut-out is located on the bottom of the oven cavity. It is designed to prevent damage to the oven unit if the food in the oven catches fire due to overheating produced by improper setting of cooking time or failure of control unit.

Under normal operation, the thermal cut-out remains closed. However, the thermal cut-out will open at 293°F (145°C) causing the oven to shut down. The defective thermal cut-out must be replaced with a new one.

TURNTABLE MOTOR

The turntable motor rotates the turntable located on the bottom of the oven cavity, so that the foods on the turntable cook evenly during cooking. Turntable will turn in either direction. The turntable motor can be turned off by touching TURNTABLE ON/OFF pad.

COOLING FAN MOTOR

The cooling fan motor drives a blade which draws external cool air. This cool air is directed through the air vanes surrounding the magnetron and cools the magnetron. This air

is channelled through the oven cavity to remove steam and vapors given off from the heating foods. It is then exhausted through the exhausting air vents at the oven cavity.

HOOD FAN MOTOR

The hood fan motor is a two-speed, single-phase, double pole induction type, requiring a hood fan capacitor. It is located outside the upper rear part of the oven cavity, is to remove, from around the oven, hot air rising from the conventional electric or gas range over which it is installed.

This air is then expelled either vertically or horizontally through the customer supplied duct system, or discharged back into the kitchen.

HOOD LAMP

The hood lamps are mounted at the hood lamp angle on the base cover. The hood lamps can be turned off and on by touching the LIGHT HI/ LO button. And also the brightness can be varied to high or low by touching the LIGHT HI/ LO button.

TROUBLESHOOTING GUIDE

Never touch any part in the circuit with your hand or an uninsulated tool while the power supply is connected.

When troubleshooting the microwave oven, it is helpful to follow the Sequence of Operation in performing the checks. Many of the possible causes of trouble will require that a specific test be performed. These tests are given a procedure letter which will be found in the "Test Procedure "section.

IMPORTANT: If the oven becomes inoperative because of a blown monitor fuse, check the monitor switch, relay (RY1) secondary interlock relay (RY2), door sensing switch and primary interlock switch before replacing the monitor fuse. If monitor fuse is replaced, the monitor switch must also be replaced. Use part FFS-BA016/ KiT as an assembly.

IMPORTANT: Whenever troubleshooting is performed with the power supply cord disconnected. It may in, some cases, be necessary to connect the power supply cord after the outer case has been removed, in this event,

1. Disconnect the power supply cord, and then remove outer case.
2. Open the door and block it open.
3. Discharge high voltage capacitor.
4. Disconnect the leads to the primary of the power transformer.
5. Ensure that the leads remain isolated from other components and oven chassis by using insulation tape.
6. After that procedure, reconnect the power supply cord.

When the testing is completed

1. Disconnect the power supply cord, and then remove outer case.
2. Open the door and block it open.
3. Discharge high voltage capacitor.
4. Reconnect the leads to the primary of the power transformer.
5. Reinstall the outer case (cabinet).
6. Reconnect the power supply cord after the outer case is installed.
7. Run the oven and check all functions.

TEST PROCEDURE																									
CONDITION	PROBLEM	CK	RE	CK	RE	CK	RE	CK	RE	CK	RE	CK	RE	CK	RE	CK	RE	CK	RE	CK	RE	CK	RE		
OFF CONDITION	Home fuse blows when power cord is plugged into wall receptacle.		●																						
	Monitor fuse blows when power cord is plugged into wall receptacle.			●																					
	Display does not illuminate when power cord is first plugged into wall receptacle.			●																					
	Display does not operate properly when STOP/CLEAR button is touched. (The time of day should appear on the display with beep sound during normal condition.)				●																				
	Oven lamp does not light with door is opened.																								
	Hood fan motor operates when power cord is first plugged into wall receptacle.																								
	Temperature of oven base seems more than 140°F (60°C) because of operation of the range below. But hood fan motor does not turn on automatically. (Normally, food fan motor should be operating at low speed.)																								
	Hood lights do not turn on when LIGHT HI/LO button is pressed.																								
	Hood fan motor does not rotate at all with touched FAN HI/LO button.																								
	Speed of the hood fan motor does not change when the FAN HI/LO button is touched for this function.																								
IDLE CONDITION	Oven lamp does not light in cook cycle. (But it does light when door is opened.)																								
	Fan motor does not operate. (Oven lamp and turntable motor operate.)																								
MICROWAVE COOKING CONDITION	Turntable motor does not operate (Oven lamp lights and fan motor operate.)																								
	Oven does not go into cook cycle when START button is touched																								
	Oven seems to be operating but little or no heat is produced in oven load. (Food incompletely cooked or not cooked at all at end of cook cycle.)																								
	Oven goes into a cook cycle but extremely uneven heating is produced in oven load (food).																								
MICROWAVE COOKING CONDITION	Variable cooking does not operate properly except Cooking Power 10 (P-HI) mode.																								
	Function of DEFROST CENTER does not operate properly.																								
MICROWAVE COOKING CONDITION	Oven goes into DEFROST CENTER but food is not defrosted well.																								

TEST PROCEDURES

PROCEDURE LETTER	COMPONENT TEST
A	<u>MAGNETRON ASSEMBLY TEST</u> <ol style="list-style-type: none">1. Disconnect the power supply cord, and then remove outer case.2. Open the door and block it open.3. Discharge high voltage capacitor.4. To test for an open filament, isolate the magnetron from the high voltage circuit. A continuity check across the magnetron filament leads should indicate less than 1 ohm.5. To test for a shorted magnetron, connect the ohmmeter leads between the magnetron filament leads and chassis ground. This test should indicate an infinite resistance. If there is little or no resistance the magnetron is grounded and must be replaced.6. Reconnect all leads removed from components during testing.7. Reinstall the outer case (cabinet).8. Reconnect the power supply cord after the outer case is installed.9. Run the oven and check all functions. MICROWAVE OUTPUT POWER <p>The following test procedure should be carried out with the microwave oven in a fully assembled condition (outer case fitted).</p> <p>HIGH VOLTAGES ARE PRESENT DURING THE COOK CYCLE, SO EXTREME CAUTION SHOULD BE OBSERVED.</p> <p>Power output of the magnetron can be measured by performing a water temperature rise test. This test should only be used if above tests do not indicate a faulty magnetron and there is no defect in the following components or wiring: silicon rectifier, high voltage capacitor and power transformer. This test will require a 16 ounce (453cc) measuring cup and an accurate mercury thermometer or thermocouple type temperature tester. For accurate results, the following procedure must be followed carefully:</p> <ol style="list-style-type: none">1. Fill the measuring cup with 16 oz. (453cc) of tap water and measure the temperature of the water with a thermometer or thermocouple temperature tester. Stir the thermometer or thermocouple through the water until the temperature stabilizes. Record the temperature of the water.2. Place the cup of water in the oven. Operate oven at POWER 10(HIGH) selecting more than 60 seconds cook time. Allow the water to heat for 60 seconds, measuring with a stop watch, second hand of a watch or the digital read-out countdown.3. Remove the cup from the oven and again measure the temperature, making sure to stir the thermometer or thermocouple through the water until the maximum temperature is recorded.4. Subtract the cold water temperature from the hot water temperature. The normal result should be 29.2 to 54.2°F(16.2 to 30.1°C) rise in temperature. If the water temperatures are accurately measured and tested for the required time period the test results will indicate if the magnetron tube has low power output (low rise in water temperature) which would extend cooking time or high power output (high rise in water temperature) which would reduce cooking time. Because cooking time can be adjusted to compensate for power output, the magnetron tube assembly should be replaced only if the water temperature rise test indicates a power output well beyond the normal limits. The test is only accurate if the power supply line voltage is 120 volts and the oven cavity is clean.
B	<u>POWER TRANSFORMER TEST</u> <ol style="list-style-type: none">1. Disconnect the power supply cord, and then remove outer case.2. Open the door and block it open.3. Discharge high voltage capacitor.4. Disconnect the primary input terminals and measure the resistance of the transformer with an ohmmeter. Check for continuity of the coils with an ohmmeter. On the R x 1 scale, the resistance of the primary coil should be less than 1 ohm and the resistance of the high voltage coil should be approximately 83 ohms; the resistance of the filament coil should be less than 1 ohm.5. Reconnect all leads removed from components during testing.6. Reinstall the outer case (cabinet).7. Reconnect the power supply cord after the outer case is installed.8. Run the oven and check all functions.

TEST PROCEDURES

PROCEDURE LETTER	COMPONENT TEST
	(HIGH VOLTAGES ARE PRESENT AT THE HIGH VOLTAGE TERMINAL, SO DO NOT ATTEMPT TO MEASURE THE FILAMENT AND HIGH VOLTAGE.)
C	<u>HIGH VOLTAGE RECTIFIER TEST</u> <ol style="list-style-type: none">1. Disconnect the power supply cord, and then remove outer case.2. Open the door and block it open.3. Discharge high voltage capacitor.4. Isolate the rectifier from the circuit. Using the highest ohm scale of the meter, read the resistance across the terminals and observe, reverse the leads to the rectifier terminals and observe meter reading. If a short is indicated in both directions, or if an infinite resistance is read in both directions, the rectifier is probably defective and should be replaced.5. Reconnect all leads removed from components during testing.6. Reinstall the outer case (cabinet).7. Reconnect the power supply cord after the outer case is installed.8. Run the oven and check all functions. <p>NOTE: Be sure to use an ohmmeter that will supply a forward bias voltage of more than 6.3 volts.</p>
D	<u>HIGH VOLTAGE CAPACITOR TEST</u> <ol style="list-style-type: none">1. Disconnect the power supply cord, and then remove outer case.2. Open the door and block it open.3. Discharge high voltage capacitor.4. If the capacitor is open, no high voltage will be available to the magnetron. Disconnect input leads and check for short or open between the terminals using an ohmmeter. Checking with a high ohm scale, if the high voltage capacitor is normal, the meter will indicate continuity for a short time and should indicate an open circuit once the capacitor is charged. If the above is not the case, check the capacitor with an ohmmeter to see if it is shorted between either of the terminals and case. If it is shorted, replace the capacitor.5. Reconnect all leads removed from components during testing.6. Reinstall the outer case (cabinet).7. Reconnect the power supply cord after the outer case is installed.8. Run the oven and check all functions.
E	<u>CAVITY THERMAL CUT-OUT TEST</u> <ol style="list-style-type: none">1. Disconnect the power supply cord, and then remove outer case.2. Open the door and block it open.3. Discharge high voltage capacitor.4. A continuity check across the thermal cut-out terminals should indicate a closed circuit unless the temperature of the thermal cut-out reaches approximately 293°F(145°C). An open thermal cut-out indicates overheating of the oven, exchange the oven thermal cut-out and check inside of oven cavity and for improper setting of cooking time or operation of control unit. Check for restricted air flow through the vent holes of the oven cavity, especially the cooling fan and air guide.5. Reconnect all leads removed from components during testing.6. Reinstall the outer case (cabinet).7. Reconnect the power supply cord after the outer case is installed.8. Run the oven and check all functions. <u>MAGNETRON TEMPERATURE FUSE TEST</u> <ol style="list-style-type: none">1. Disconnect the power supply cord, and then remove outer case.2. Open the door and block it open.3. Discharge high voltage capacitor.4. A continuity check across the temperature fuse terminals should indicate a closed circuit. If the temperature of the magnetron reaches approximately 302°F(150°C), the temperature fuse opens. An open temperature fuse indicates overheating of the magnetron. Check for restricted air flow to the magnetron, especially the cooling fan air guide.5. Reconnect all leads removed from components during testing.

TEST PROCEDURES

PROCEDURE LETTER	COMPONENT TEST
	<ol style="list-style-type: none">6. Reinstall the outer case (cabinet).7. Reconnect the power supply cord after the outer case is installed.8. Run the oven and check all functions. <p>CAUTION: IF THE THERMAL CUT-OUT OR TEMPERATURE FUSE INDICATES AN OPEN CIRCUIT AT ROOM TEMPERATURE, REPLACE THERMAL CUT-OUT OR TEMPERATURE FUSE.</p>
F	<u>PRIMARY INTERLOCK SWITCH TEST</u> <ol style="list-style-type: none">1. Disconnect the power supply cord, and then remove outer case.2. Open the door and block it open.3. Discharge high voltage capacitor.4. Isolate the switch and connect the ohmmeter to the common (COM.) and normally open (NO) terminal of the switch. The meter should indicate an open circuit with the door open and a closed circuit with the door closed. If improper operation is indicated, replace the secondary interlock switch.5. Reconnect all leads removed from components during testing.6. Reinstall the outer case (cabinet).7. Reconnect the power supply cord after the outer case is installed.8. Run the oven and check all functions.
G	<u>SECONDARY INTERLOCK SYSTEM TEST</u> <p><u>DOOR SENSING SWITCH</u></p> <ol style="list-style-type: none">1. Disconnect the power supply cord, and then remove outer case.2. Open the door and block it open.3. Discharge high voltage capacitor.4. Isolate the switch and connect the ohmmeter to the common (COM.) and normally open (NO) terminal of the switch. The meter should indicate an open circuit with the door open and a closed circuit with the door closed. If improper operation is indicated, replace the door sensing switch.5. Reconnect all leads removed from components during testing.6. Reinstall the outer case (cabinet).7. Reconnect the power supply cord after the outer case is installed.8. Run the oven and check all functions. <p>NOTE: If the door sensing switch contacts fail in the open position and the door is closed, the cooling fan motor, stirrer motor and oven light will be activated by RY1.</p> <p><u>SECONDARY INTERLOCK RELAY (RY2)</u></p> <ol style="list-style-type: none">1. Disconnect the power supply cord, and then remove outer case.2. Open the door and block it open.3. Discharge high voltage capacitor.4. Disconnect two (2) wire leads from the male tab terminals of the Secondary Interlock Relay. Check the state of the relay contacts using a ohmmeter. The relay contacts should be open. If the relay contacts are closed, replace the circuit board entirely or the relay itself.5. Reconnect all leads removed from components during testing.6. Reinstall the outer case (cabinet).7. Reconnect the power supply cord after the outer case is installed.8. Run the oven and check all functions.
H	<u>MONITOR SWITCH TEST</u> <ol style="list-style-type: none">1. Disconnect the power supply cord, and then remove outer case.2. Open the door and block it open.3. Discharge high voltage capacitor.4. Before performing this test, make sure that the primary interlock switch and the secondary interlock relay are operating properly, according to the above Switch and Interlock system Test Procedures. Disconnect the wire lead from the monitor switch (COM) terminal. Check the monitor switch operation by using the ohmmeter as follows. When the door is open, the meter should indicate a closed circuit. When the monitor switch actuator is pushed by a screw driver through the lower latch hole on the front

TEST PROCEDURES

PROCEDURE LETTER

COMPONENT TEST

plate of the oven cavity with the door opened (in this condition the plunger of the monitor switch is pushed in), the meter should indicate an open circuit. If improper operation is indicated, the switch may be defective. After testing the monitor switch, reconnect the wire lead to the monitor switch (COM) terminal and check the continuity of the monitor circuit.

5. Reconnect all leads removed from components during testing.
6. Reinstall the outer case (cabinet).
7. Reconnect the power supply cord after the outer case is installed.
8. Run the oven and check all functions.

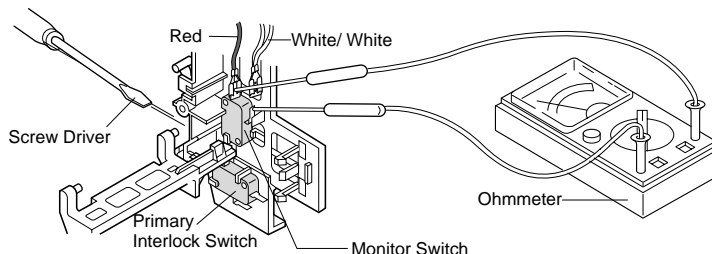

I BLOWN MONITOR FUSE TEST

1. Disconnect the power supply cord, and then remove outer case.
2. Open the door and block it open.
3. Discharge high voltage capacitor.
4. If the monitor fuse is blown when the door is opened, check the secondary interlock relay, primary interlock switch and monitor switch according to the "TEST PROCEDURE" for those switches before replacing the blown monitor fuse.

CAUTION: BEFORE REPLACING A BLOWN MONITOR FUSE, TEST THE SECONDARY INTERLOCK RELAY, PRIMARY INTERLOCK SWITCH, DOOR SENSING SWITCH AND MONITOR SWITCH FOR PROPER OPERATION.

If the monitor fuse is blown by improper switch operation, the monitor fuse and monitor switch must be replaced with "monitor fuse and monitor switch assembly" part number FFS-BA016/KiT, even if the monitor switch operates normally. The monitor fuse and monitor switch assembly is comprised of a 20 ampere fuse and switch.

5. Reconnect all leads removed from components during testing.
6. Re-install the outer case (cabinet).
7. Reconnect the power supply cord after the outer case is installed.
8. Run the oven and check all functions.

J HOOD THERMAL CUT-OUT TEST

1. Disconnect the power supply cord, and then remove outer case.
2. Open the door and block it open.
3. Discharge high voltage capacitor.
4. A continuity check across the thermal cut-out terminals should indicate an open circuit unless the temperature of the thermal cut-out reaches approximately 140°F(60°C) or more. At that temperature, the contacts will close. The thermal cut-out opens automatically at approximately 113°F(45°C).
5. Reconnect all leads removed from components during testing.
6. Reinstall the outer case (cabinet).
7. Reconnect the power supply cord after the outer case is installed.
8. Run the oven and check all functions.

K HOOD FAN MOTOR TEST

1. Disconnect the power supply cord, and then remove outer case.
2. Open the door and block it open.
3. Discharge high voltage capacitor.
4. If the motor does not turn, touch the FAN HI / LO button once (set hood fan motor power "HIGH") and check voltage between pins "1" and "2" (Blue and Black wires) of the 6 pin connector. If 120 Volts appear and the hood capacitor is good, replace the hood fan assembly. If 120 Volts does not appear, check the motor circuit. The resistance values of motor terminals are as follows:

TEST PROCEDURES

**PROCEDURE
LETTER**

COMPONENT TEST

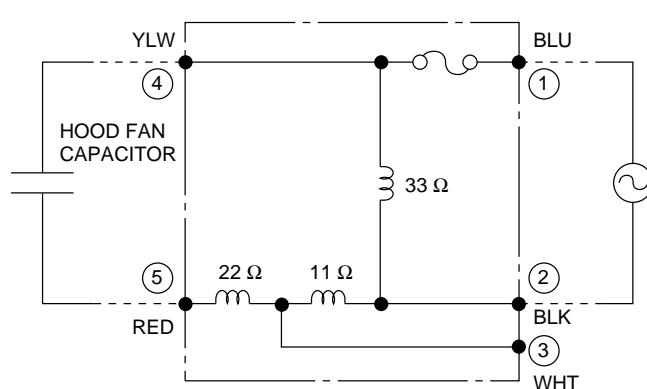

Resistance between:

- BLU (1) AND YLW (4) = 0Ω (Shorted)
- BLK (2) AND YLW (4) = 33Ω
- BLU (1) AND BLK (2) = 33Ω
- BLK (2) AND WHT (3) = 11Ω
- WHT (3) AND RED (5) = 22Ω

6-PIN CONNECTOR
OF HOOD FAN MOTOR

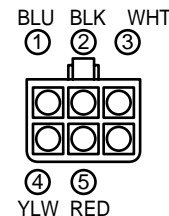

5. Reconnect all leads removed from components during testing.
6. Reinstall the outer case (cabinet).
7. Reconnect the power supply cord after the outer case is installed.
8. Run the oven and check all functions.

L TOUCH CONTROL PANEL ASSEMBLY TEST

The touch control panel consists of circuits including semiconductors such as LSI, ICs, etc. Therefore, unlike conventional microwave ovens, proper maintenance cannot be performed with only a voltmeter and ohmmeter. In this service manual, the touch control panel assembly is divided into two units, Control Unit and Key Unit, and also the Control Unit is divided into two units, LSI Unit and Power Unit, and troubleshooting by unit replacement is described according to the symptoms indicated.

Before testing,

- 1) Disconnect the power supply cord, and then remove outer case. Refer to procedure of " HOOD EXHAUST LOUVER REMOVAL ", " REMOVAL OF OVEN FROM WALL " and " OUTER CASE REMOVAL ".
- 2) Open the door and block it open.
- 3) To discharge high voltage capacitor, wait for 60 seconds.
- 4) Remove two (2) screws holding the hood intake duct R to the ovencavity top plate and the base plate R. And remove the hood intake duct R.
- 5) Disconnect the leads to the primary of the power transformer.
- 6) Ensure that these leads remain isolated from other components and oven chassis by using insulation tape.

1. Key Unit.

NOTE ;

- 1) Check key unit ribbon connection before replacement.
- 2) Reconnect all leads removed from components during testing.
- 3) Re-install the hood intake duct R with two (2) screws.
- 4) Re-install the outer case (cabinet).
- 5) Reconnect the power supply cord after the outer case is installed.
- 6) Run the oven and check all functions.

The following symptoms indicate a defective key unit.

- a) When touching the pads, a certain pad produces no signal at all.
- b) When touching a number pad, two figures or more are displayed.
- c) When touching the pads, sometimes a pad produces no signal.

If the key unit is defective.

- 1) Disconnect the power supply cord, and then remove outer case.
- 2) Open the door and block it open.
- 3) To discharge high voltage capacitor, wait for 60 seconds.
- 4) Replace the key unit.
- 5) Reconnect all leads removed from components during testing.
- 6) Re-install the outer case (cabinet).
- 7) Reconnect the power supply cord after the outer case is installed.

TEST PROCEDURES

PROCEDURE LETTER

COMPONENT TEST

- 8) Run the oven and check all functions.
 2. Control Unit.
The following symptoms indicate a defective control unit. Before replacing the control unit, perform the Key unit test (Procedure M) to determine if control unit is faulty.
 - 2-1 In connection with pads.
 - a) When touching the pads, a certain group of pads do not produce a signal.
 - b) When touching the pads, no pads produce a signal.
 - 2-2 In connection with indicators
 - a) At a certain digit, all or some segments do not light up.
 - b) At a certain digit, brightness is low.
 - c) Only one indicator does not light.
 - d) The corresponding segments of all digits do not light up; or they continue to light up.
 - e) Wrong figure appears.
 - f) A certain group of indicators do not light up.
 - g) The figure of all digits flicker.
 - 2-3 Other possible problems caused by defective control unit.
 - a) Buzzer does not sound or continues to sound.
 - b) Clock does not operate properly.
 - c) Cooking is not possible.
- When testing is completed,
- 1) Disconnect the power supply cord.
 - 2) Open the door and block it open.
 - 3) To discharge high voltage capacitor, wait for 60 seconds.
 - 4) Reconnect all leads removed from components during testing.
 - 5) Re-install the hood intake duct R.
 - 6) Re-install the outer case (cabinet).
 - 7) Reconnect the power supply cord after the outer case is installed.
 - 8) Run the oven and check all functions.

M KEY UNIT TEST

1. Disconnect the power supply cord.
2. Open the door and block it open.
3. To discharge high voltage capacitor, wait for 60 seconds.
4. Remove the control panel assembly.
5. If the display fails to clear when the STOP/CLEAR pad is depressed, first verify the flat ribbon cable is making good contact, verify that the door sensing switch (stop switch) operates properly; that is the contacts are closed when the door is closed and open when the door is open. If the door sensing switch (stop switch) is good, disconnect the flat ribbon cable that connects the key unit to the control unit and make sure the door sensing switch is closed (either close the door or short the door sensing switch connector). Use the Key unit matrix indicated on the control panel schematic and place a jumper wire between the pins that correspond to the STOP/CLEAR pad making momentary contact. If the control unit responds by clearing with a beep the key unit is faulty and must be replaced. If the control unit does not respond, it is faulty and must be replaced. If a specific pad does not respond, the above method may be used (after clearing the control unit) to determine if the control unit or key pad is at fault.
6. Reconnect all leads removed from components during testing.
7. Re-install the control panel assembly.
8. Reconnect the power supply cord.
9. Run the oven and check all functions.

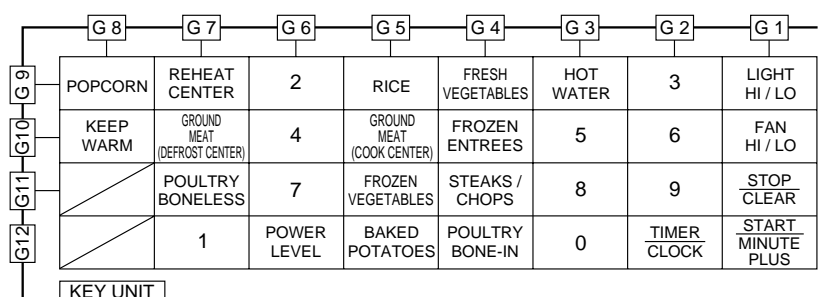

TEST PROCEDURES

PROCEDURE LETTER	COMPONENT TEST
------------------	----------------

N RELAY TEST

1. Disconnect the power supply cord, and then remove outer case. Refer to procedure of " HOOD EXHAUST LOUVER REMOVAL ", " REMOVAL OF OVEN FROM WALL " and " OUTER CASE REMOVAL ".
2. Open the door and block it open.
3. To discharge high voltage capacitor, wait for 60 seconds.
4. Remove the hood intake duct R.
5. Disconnect the leads to the primary of the power transformer.
6. Ensure that these leads remain isolated from other components and oven chassis by using insulation tape.
7. After that procedure, re-connect the power supply cord.
8. Check voltage between normal open terminal of the relay RY2 and the normal open terminal of the relay RY1 on the control unit with an A.C. voltmeter.

The meter should indicate 120 volts, if not check oven circuit.

RY1, RY2, RY3, RY4, RY5 and RY6 Relay Test

These relays are operated by D.C. voltage

Check voltage at the relay coil with a D.C. voltmeter during the microwave cooking operation.

DC. voltage indicated Defective relay.

DC. voltage not indicated Check diode which is connected to the relay coil. If diode is good, control unit is defective.

RELAY SYMBOL	OPERATIONAL VOLTAGE	CONNECTED COMPONENTS
RY1	Approx. 26.6V D.C.	Oven lamp / Fan motor / Turntable motor
RY2(COOK)	Approx. 26.0V D.C.	Power transformer
RY3	Approx. 26.6V D.C.	Hood motor
RY4	Approx. 26.6V D.C.	Hood motor
RY5	Approx. 26.6V D.C.	Hood lamp
RY6	Approx. 26.6V D.C.	Hood lamp

9. Disconnect the power supply cord.
10. Open the door and block it open.
11. To discharge high voltage capacitor, wait for 60 seconds.
12. Reconnect all leads removed from components during testing.
13. Re-install the hood intake duct R.
14. Re-install the outer case (cabinet).
15. Reconnect the power supply cord after the outer case is installed.
16. Run the oven and check all functions.

O DEFROST CENTER TEST

- (1) Open the door.
- (2) Place one cup of water in the center of the turntable tray in the oven cavity.
- (3) Touch the " STEAKS/CHOPS " pad once.
- (4) Close the door.
- (5) Touch the " START " button.
- (6) The oven is in Defrost center cooking condition.
- (7) The oven will operate as follows.

Menu	1ST STAGE		2ND STAGE	
	LEVEL	TIME	LEVEL	TIME
Steaks/Chops 0.5lbs	60%	57sec.	40%	17sec.

- (8) If improper operation is indicated, the control unit is probably defective and should be checked.

P FOIL PATTERN ON THE PRINTED WIRING BOARD TEST

To protect the electronic circuits, this model is provided with a fine foil pattern added to the primary on the PWB, this foil pattern acts as a fuse.

TEST PROCEDURES

**PROCEDURE
LETTER**

COMPONENT TEST

1. Foil pattern check and repairs.
 - 1) Disconnect the power supply cord.
 - 2) Open the door and block it open.
 - 3) To discharge high voltage capacitor, wait for 60 seconds.
 - 4) Remove the control unit, referring to the procedure of " CONTROL PANEL ASSEMBLY, CONTROL UNIT AND KEY UNIT REMOVAL ".
 - 5) Follow the troubleshooting guide given below for repair.

STEPS	OCCURRENCE	CAUSE OR CORRECTION
1	Only pattern at "a" is broken.	*Insert jumper wire J1 and solder.
2	Pattern at "a" and "b" are broken.	*Insert the coil RCILF2003YAZZ between "c" and "d".

- 6) Make a visual inspection of the varistor. Check for burned damage and examine the transformer with a tester for the presence of layer short-circuit (check the primary coil resistance which is approximately $780\Omega \pm 10\%$). If any abnormal condition is detected, replace the defective parts.

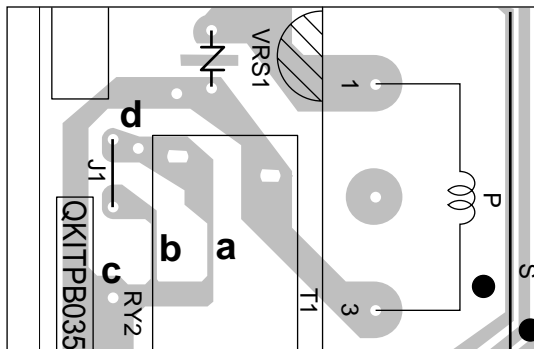

- 7) Reconnect all leads removed from components during testing.
- 8) Re-install the control unit to the control panel and re-install the control panel to the oven.
- 9) Reconnect the power supply cord.
- 10) Run the oven and check all functions.
2. Follow the troubleshooting guide given below, if indicator does not light up after above check and repairs are finished.
 - 1) Disconnect the power supply cord, and then remove outer case. Refer to procedure of " HOOD EXHAUST LOUVER REMOVAL ", " REMOVAL OF OVEN FROM WALL " and " OUTER CASE REMOVAL ".
 - 2) Open the door and block it open.
 - 3) To discharge high voltage capacitor, wait for 60 seconds.
 - 4) Remove the hood intake duct R.
 - 5) Disconnect the leads to the primary of the power transformer.
 - 6) Ensure that these leads remain isolated from other components and oven chassis by using insulation tape.
 - 7) After that procedure, re-connect the power supply cord.
 - 8) Follow the troubleshooting guide given below for repair.

STEPS	OCCURRENCE	CAUSE OR CORRECTION
1	The rated AC voltage is not present between the normal open terminal of the relay RY2 and the normal open terminal of the relay RY1.	Check supply voltage and oven power cord.
2	The rated AC voltage is present at primary side of low voltage transformer.	Low voltage transformer or secondary circuit defective. Check and repair.

- 9) Disconnect the power supply cord.
- 10) Open the door and block it open.
- 11) To discharge high voltage capacitor, wait for 60 seconds.
- 12) Reconnect all leads removed from components during testing.
- 13) Re-install the hood intake duct R.
- 14) Re-install the outer case (cabinet).
- 15) Reconnect the power supply cord after the outer case is installed.
- 16) Run the oven and check all functions.

TOUCH CONTROL PANEL ASSEMBLY

OUTLINE OF TOUCH CONTROL PANEL

The touch control section consists of the following units as shown in the touch control panel circuit.

- (1) Key Unit
- (2) Control Unit (The Control unit consists of LSI Unit and Power U nit)

The principal functions of these units and the signals communicated among them are explained below.

Key Unit

The key unit is composed of a matrix, signals generated in the LSI are sent to the key unit through P20, P21, P22, P23, P24, P25, P26 and P27.

When a key pad is touched, a signal is completed through the key unit and passed back to the LSI through P43, P44, P45 and P46 to perform the function that was requested.

Control Unit

Control unit consists of LSI, power source circuit, synchronizing signal circuit, ACL circuit, buzzer circuit, relay circuit indicator circuit and back light circuit.

1) LSI

This LSI controls the key strobe signal, relay driving signal for oven function and indicator signal.

2) Power Source Circuit

This circuit generates voltages necessary for the control unit from the AC line voltage.

In addition, the synchronizing signal is available in order to compose a basic standard time in the clock circuit.

Symbol	Voltage	Application
VC	-5.3V	LSI(IC1)

3) Synchronizing Signal Circuit

The power source synchronizing signal is available in order to compose a basic standard time in the clock circuit. It incorporates a very small error because it works on commercial frequency.

4) ACL Circuit

A circuit to generate a signals which resetting the LSI to the initial state when power is applied.

5) Buzzer Circuit

The buzzer is responds to signals from the LSI to emit audible sounds (key touch sound and completion sound).

6) Door Sensing Switch

A switch to inform the LSI if the door is open or closed.

7) Relay Circuit

To drive the magnetron, fan motor, turntable motor, hood motor, and light the oven lamp and hood lamp.

8) Indicator Circuit

This circuit consists of 22 segments and 3 common electrodes using a Light Crystal Display.

9) Back Light Circuit

A circuit to drive the back light (Light emitting diodes LD1-LD4).

DESCRIPTION OF LSI

LSI

The I/O signal of the LSI is detailed in the following table.

Pin No.	Signal	I/O	Description
1-2	VL2-VL1	IN	Power source voltage input terminal. Standard voltage for LCD.
3-6	AN7-AN4	IN	Terminal to change cooking input according to the Model. By using the A/D converter contained in the LSI, DC voltage in accordance with the Model in operation is applied to set up its cooking constant.
7	AN3	OUT	Back light circuit (Light emitting diodes) driving signal.
8	AN2	IN	To input signal which communicates the door open/close information to LSI. Door close "H" level signal (0V). Door open "L" level signal (-5V).
9-10	AN1-AN0	OUT	Terminal not used.
11-13	P57-P55	OUT	Terminal not used.
14	CNTR0	OUT	Signal to sound buzzer (2.0 kHz). A: key touch sound. B: Completion sound.

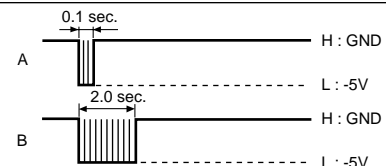

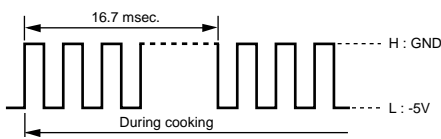
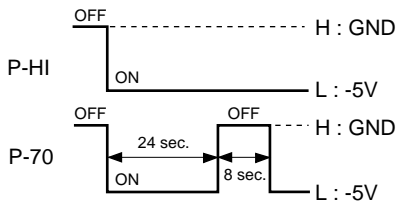
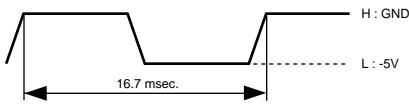
Pin No.	Signal	I/O	Description
15	P53	OUT	Terminal not used.
16	P52	OUT	<p>Oven lamp, fan motor and turntable motor driving signal</p> <p>To turn on and off shut off relay (RY1). The square waveform voltage is delivered to the RY1 driving circuit and RY2 control circuit.</p> 
17-18	P51-P50	OUT	Terminal not used.
19	P47	OUT	<p>Magnetron high-voltage circuit driving signal.</p> <p>To turn on and off the cook relay (RY2). The signals holds "L" level during microwave cooking and "H" level while not cooking. In other cooking modes (variable cooking) the signal turns to "H" level and "L" level in repetition according to the power level.</p>  <p style="text-align: right;">(ON and OFF times for other power level.)</p>
20	P46	IN	<p>Signal coming from touch key.</p> <p>When either G12 line on key matrix is touched, a corresponding signal out of P20 - P27 will be input into P46. When no key is touched, the signal is held at "H" level.</p>
21	P45	IN	<p>Signal similar to P46.</p> <p>When either G11 line on key matrix is touched, a corresponding signal will be input into P45.</p>
22	P44	IN	<p>Signal similar to P46.</p> <p>When either G10 line on key matrix is touched, a corresponding signal will be input into P44.</p>
23	P43	IN	<p>Signal similar to P46.</p> <p>When either G9 line on key matrix is touched, a corresponding signal will be input into P43.</p>
24	INT0	IN	<p>Signal synchronized with commercial power source frequency.</p> <p>This is the basic timing for time processing of LSI.</p> 
25	P41	OUT	Terminal not used.
26	P40	IN	Connected to GND through the pull-down resistor R100.
27	RESET	IN	<p>Auto clear terminal.</p> <p>Signal is input to reset the LSI to the initial state when power is applied.</p>
28-29	P71-P70	OUT	Terminal not used.
30	XIN	IN	<p>Internal clock oscillation frequency input setting.</p> <p>The internal clock frequency is set by inserting the ceramic filter oscillation circuit with respect to XOUT terminal.</p>
31	XOUT	OUT	<p>Internal clock oscillation frequency control output.</p> <p>Output to control oscillation input of XIN.</p>
32	VSS	IN	<p>Power source voltage: -5.0V.</p> <p>VC voltage of power source circuit input.</p>
33	P27	OUT	<p>Key strobe signal.</p> <p>Signal applied to touch-key section. A pulse signal is input to P43-P46 terminal while one of G8 line keys on key matrix is touched.</p>
34	P26	OUT	<p>Key strobe signal.</p> <p>Signal applied to touch-key section. A pulse signal is input to P43-P46 terminal while one of G7 line keys on key matrix is touched.</p>
35	P25	OUT	<p>Key strobe signal.</p> <p>Signal applied to touch-key section. A pulse signal is input to P43-P46 terminal while one of G6 line keys on key matrix is touched.</p>
36	P24	OUT	<p>Key strobe signal.</p> <p>Signal applied to touch-key section. A pulse signal is input to P43-P46 terminal while one of G5 line keys on key matrix is touched.</p>

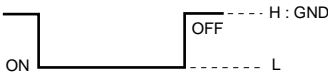
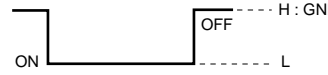
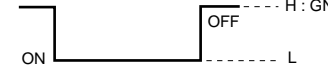
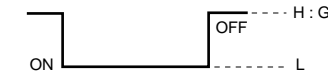
Pin No.	Signal	I/O	Description																																																
37	P23	OUT	Key strobe signal. Signal applied to touch-key section. A pulse signal is input to P43-P46 terminal while one of G4 line keys on key matrix is touched.																																																
38	P22	OUT	Key strobe signal. Signal applied to touch-key section. A pulse signal is input to P43-P46 terminal while one of G3 line keys on key matrix is touched.																																																
39	P21	OUT	Key strobe signal. Signal applied to touch-key section. A pulse signal is input to P43-P46 terminal while one of G2 line keys on key matrix is touched.																																																
40	P20	OUT	Key strobe signal. Signal applied to touch-key section. A pulse signal is input to P43-P46 terminal while one of G1 line keys on key matrix is touched.																																																
41	P17	OUT	Hood lamp driving signal. To turn on and off relay(RY6). "L" level: During Hood lamp ON. "H" level: During Hood lamp OFF. 																																																
42	P16	OUT	Hood lamp driving signal. To turn on and off relay(RY5). "L" level: During Hood lamp ON. "H" level: During Hood lamp OFF. 																																																
43	P15	OUT	Hood motor high / low driving signal. To turn on and off relay(RY3). "L" level: During Hood motor high. "H" level: During Hood motor low. 																																																
44	P14	OUT	Hood motor driving signal. To turn on and off relay(RY4). "L" level: During Hood motor ON. "H" level: During Hood motor OFF. 																																																
45-47	P13-P11	OUT	Terminal not used.																																																
48-50	SEG24-SEG22	OUT	Terminal not used.																																																
51-72	SEG21-SEG0	OUT	Segment data signal. Connected to LCD. The relation between signals are as follows: <table border="0" style="width: 100%; border-collapse: collapse;"> <thead> <tr> <th style="text-align: left;">LSI signal (Pin No.)</th> <th style="text-align: left;">LCD (Pin No.)</th> <th style="text-align: left;">LSI signal (Pin No.)</th> <th style="text-align: left;">LCD (Pin No.)</th> </tr> </thead> <tbody> <tr> <td>SEG 21 (51)</td> <td>SEG21 (1)</td> <td>SEG 10 (62)</td> <td>SEG10 (12)</td> </tr> <tr> <td>SEG 20 (52)</td> <td>SEG20 (2)</td> <td>SEG 9 (63)</td> <td>SEG 9 (13)</td> </tr> <tr> <td>SEG 19 (53)</td> <td>SEG19 (3)</td> <td>SEG 8 (64)</td> <td>SEG 8 (14)</td> </tr> <tr> <td>SEG 18 (54)</td> <td>SEG18 (4)</td> <td>SEG 7 (65)</td> <td>SEG 7 (15)</td> </tr> <tr> <td>SEG 17 (55)</td> <td>SEG17 (5)</td> <td>SEG 6 (66)</td> <td>SEG 6 (16)</td> </tr> <tr> <td>SEG 16 (56)</td> <td>SEG16 (6)</td> <td>SEG 5 (67)</td> <td>SEG 5 (17)</td> </tr> <tr> <td>SEG 15 (57)</td> <td>SEG15 (7)</td> <td>SEG 4 (68)</td> <td>SEG 4 (18)</td> </tr> <tr> <td>SEG 14 (58)</td> <td>SEG14 (8)</td> <td>SEG 3 (69)</td> <td>SEG 3 (19)</td> </tr> <tr> <td>SEG 13 (59)</td> <td>SEG13 (9)</td> <td>SEG 2 (70)</td> <td>SEG 2 (20)</td> </tr> <tr> <td>SEG 12 (60)</td> <td>SEG12 (10)</td> <td>SEG 1 (71)</td> <td>SEG 1 (21)</td> </tr> <tr> <td>SEG 11 (61)</td> <td>SEG11 (11)</td> <td>SEG 0 (72)</td> <td>SEG 0 (22)</td> </tr> </tbody> </table>	LSI signal (Pin No.)	LCD (Pin No.)	LSI signal (Pin No.)	LCD (Pin No.)	SEG 21 (51)	SEG21 (1)	SEG 10 (62)	SEG10 (12)	SEG 20 (52)	SEG20 (2)	SEG 9 (63)	SEG 9 (13)	SEG 19 (53)	SEG19 (3)	SEG 8 (64)	SEG 8 (14)	SEG 18 (54)	SEG18 (4)	SEG 7 (65)	SEG 7 (15)	SEG 17 (55)	SEG17 (5)	SEG 6 (66)	SEG 6 (16)	SEG 16 (56)	SEG16 (6)	SEG 5 (67)	SEG 5 (17)	SEG 15 (57)	SEG15 (7)	SEG 4 (68)	SEG 4 (18)	SEG 14 (58)	SEG14 (8)	SEG 3 (69)	SEG 3 (19)	SEG 13 (59)	SEG13 (9)	SEG 2 (70)	SEG 2 (20)	SEG 12 (60)	SEG12 (10)	SEG 1 (71)	SEG 1 (21)	SEG 11 (61)	SEG11 (11)	SEG 0 (72)	SEG 0 (22)
LSI signal (Pin No.)	LCD (Pin No.)	LSI signal (Pin No.)	LCD (Pin No.)																																																
SEG 21 (51)	SEG21 (1)	SEG 10 (62)	SEG10 (12)																																																
SEG 20 (52)	SEG20 (2)	SEG 9 (63)	SEG 9 (13)																																																
SEG 19 (53)	SEG19 (3)	SEG 8 (64)	SEG 8 (14)																																																
SEG 18 (54)	SEG18 (4)	SEG 7 (65)	SEG 7 (15)																																																
SEG 17 (55)	SEG17 (5)	SEG 6 (66)	SEG 6 (16)																																																
SEG 16 (56)	SEG16 (6)	SEG 5 (67)	SEG 5 (17)																																																
SEG 15 (57)	SEG15 (7)	SEG 4 (68)	SEG 4 (18)																																																
SEG 14 (58)	SEG14 (8)	SEG 3 (69)	SEG 3 (19)																																																
SEG 13 (59)	SEG13 (9)	SEG 2 (70)	SEG 2 (20)																																																
SEG 12 (60)	SEG12 (10)	SEG 1 (71)	SEG 1 (21)																																																
SEG 11 (61)	SEG11 (11)	SEG 0 (72)	SEG 0 (22)																																																
73/74	VCC/VREF	IN	Connected to GND.																																																
75	AVSS	IN	Connected to VC.																																																
76	COM3	OUT	Terminal not used.																																																
77	COM2	OUT	Common data signal: COM2. Connected to LCD signal COM2.																																																
78	COM1	OUT	Common data signal: COM1. Connected to LCD signal COM1.																																																
79	COM0	OUT	Common data signal: COM0. Connected to LCD signal COM0.																																																
80	VL3	IN	Power source voltage input terminal. Standard voltage for LCD.																																																

SERVICING

1. Precautions for Handling Electronic Components

This unit uses CMOS LSI in the integral part of the circuits. When handling these parts, the following precautions should be strictly followed. CMOS LSI have extremely high impedance at its input and output terminals. For this reason, it is easily influenced by the surrounding high voltage power source, static electricity charge in clothes, etc. and sometimes it is not fully protected by the built-in protection circuit.

In order to protect CMOS LSI.

- 1) When storing and transporting, thoroughly wrap them in aluminium foil. Also wrap all PW boards containing them in aluminium foil.
- 2) When soldering, ground the technician as shown in the figure and use grounded soldering iron and work table.

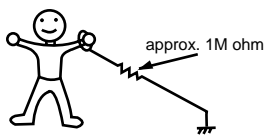

2. Shapes of Electronic Components

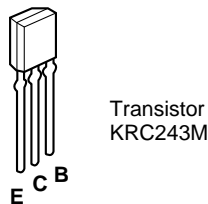

3. Servicing of Touch Control Panel

We describe the procedures to permit servicing of the touch control panel of the microwave oven and the precautions you must take when doing so. To perform the servicing, power to the touch control panel is available either from the power line of the oven itself or from an external power source.

(1) Servicing the touch control panel with power supply of the oven:

CAUTION:

THE HIGH VOLTAGE TRANSFORMER OF THE MICROWAVE OVEN IS STILL LIVE DURING SERVICING AND PRESENTS A HAZARD.

Therefore, before checking the performance of the touch control panel,

- 1) Disconnect the power supply cord, and then remove outer case.
- 2) Open the door and block it open.
- 3) Discharge high voltage capacitor.
- 4) Disconnect the leads to the primary of the power transformer.
- 5) Ensure that these leads remain isolated from other components and oven chassis by using insulation tape.
- 6) After that procedure, re-connect the power supply cord.

After checking the performance of the touch control panel,

- 1) Disconnect the power supply cord.
- 2) Open the door and block it open.
- 3) Re-connect the leads to the primary of the power

transformer.

- 4) Re-install the outer case (cabinet).
 - 5) Re-connect the power supply cord after the outer case is installed.
 - 6) Run the oven and check all functions.
- A.** On some models, the power supply cord between the touch control panel and the oven itself is so short that the two can't be separated. For those models, check and repair all the controls (sensor-related ones included) of the touch control panel while keeping it connected to the oven.
- B.** On some models, the power supply cord between the touch control panel and the oven proper is long enough that they may be separated from each other. For those models, it is possible to check and repair the controls of the touch control panel while keeping it apart from the oven proper; in this case you must short both ends of the door sensing switch (on PWB) of the touch control panel with a jumper, which activates an operational state that is equivalent to the oven door being closed. As for the sensor-related controls of the touch control panel, checking them is possible if dummy resistor(s) with resistance equal to that of the controls are used.

(2) Servicing the touch control panel with power supply from an external power source:

Disconnect the touch control panel completely from the oven proper, and short both ends of the door sensing switch (on PWB) of the touch control panel, which activates an operational state that is equivalent to the oven door being closed. Connect an external power source to the power input terminal of the touch control panel, then it is possible to check and repair the controls of the touch control panel it is also possible to check the sensor-related controls of the touch control panel by using the dummy resistor(s).

4. Servicing Tools

Tools required to service the touch control panel assembly.

- 1) Soldering iron: 30W
(It is recommended to use a soldering iron with a grounding terminal.)
- 2) Oscilloscope: Single beam, frequency range: DC-10MHz type or more advanced model.
- 3) Others: Hand tools

5. Other Precautions

- 1) Before turning on the power source of the control unit, remove the aluminium foil applied for preventing static electricity.
- 2) Connect the connectors of the key unit to the control unit being sure that the lead wires are not twisted.
- 3) After aluminium foil is removed, be careful that abnormal voltage due to static electricity etc. is not applied to the input or output terminals.
- 4) Attach connectors, electrolytic capacitors, etc. to PWB, making sure that all connections are tight.
- 5) Be sure to use specified components where high precision is required.

COMPONENT REPLACEMENT AND ADJUSTMENT PROCEDURE

WARNING AGAINST HIGH VOLTAGE:

Microwave ovens contain circuitry capable of producing very high voltage and current, contact with following parts may result in severe, possibly fatal, electric shock.

(Example)

High Voltage Capacitor, Power Transformer, Magnetron, High Voltage Rectifier Assembly, High Voltage Harness etc..

WARNING: Avoid possible exposure to microwave energy. Please follow the instructions below before operating the oven.

- | | |
|--|--|
| <ol style="list-style-type: none"> 1. Disconnect the power supply cord. 2. Make sure that a definite "click" can be heard when the microwave oven door is unlatched. (Hold the door in a closed position with one hand, then push the door open button with the other, this causes the latch leads to rise, it is then possible to hear a "click" as the door switches operate.) 3. Visually check the door and cavity face plate for damage (dents, cracks, signs of arcing etc.). | <ol style="list-style-type: none"> 1. Door does not close firmly. 2. Door hinge, support or latch hook is damaged. 3. The door gasket or seal is damaged. 4. The door is bent or warped. 5. There are defective parts in the door interlock system. 6. There are defective parts in the microwave generating and transmission assembly. 7. There is visible damage to the oven. |
|--|--|

Carry out any remedial work that is necessary before operating the oven.

Do not operate the oven if any of the following conditions exist;

Do not operate the oven:

1. Without the RF gasket (Magnetron).
2. If the wave guide or oven cavity are not intact.
3. If the door is not closed.
4. If the outer case (cabinet) is not fitted.

WARNING FOR WIRING

To prevent an electric shock, take the following precautions.

- | | |
|---|--|
| <ol style="list-style-type: none"> 1. Before wiring, <ol style="list-style-type: none"> 1) Disconnect the power supply cord. 2) Open the door block it open. 3) Discharge the high voltage capacitor and wait for 60 seconds. 2. Don't let the wire leads touch to the following parts; <ol style="list-style-type: none"> 1) High voltage parts:
Magnetron, High voltage transformer, High voltage capacitor and High voltage rectifier assembly. 2) Hot parts:
Oven lamp, Magnetron, High voltage transformer and Oven cavity. | <ol style="list-style-type: none"> 3) Sharp edge:
Bottom plate, Oven cavity, Waveguide flange, Chassis support and other metallic plate. 4) Movable parts (to prevent a fault)
Fan blade, Fan motor, Switch, Open lever, Open button. 3. Do not catch the wire leads in the outer case cabinet. 4. Insert the positive lock connector until its pin is locked and make sure that the wire leads do not come off even if the wire leads are pulled. 5. To prevent an error function, connect the wire leads correctly, referring to the Pictorial Diagram. |
|---|--|

Please refer to 'OVEN PARTS, CABINET PARTS, CONTROL PANAL PARTS, DOOR PARTS', when carrying out any of the following removal procedures:

THE FOLLOWING ADJUSTMENTS OR COMPONENT REPLACEMENT CAN BE PERFORMED WITHOUT REMOVING THE OVEN FROM THE WALL

- | | |
|--|---|
| <ol style="list-style-type: none"> 1. Hood lamps, sockets, grease filter and charcoal filter. 2. Base cover and hood lamp glass assembly. 3. Turntable motor. | <ol style="list-style-type: none"> 4. Hood exhaust louver. 5. Control panel assembly or components. |
|--|---|

HOOD EXHAUST LOUVER REMOVAL

- | | |
|--|---|
| <ol style="list-style-type: none"> 1. Disconnect the power supply cord. 2. Open the door and block it open. 3. To discharge the high voltage capacitor, wait for 60 | <p>seconds.</p> <ol style="list-style-type: none"> 4. Remove the three (3) screws holding the hood exhaust louver to the oven cavity front face plate. |
|--|---|

5. Pull the hood exhaust louver from the oven cavity by pushing the right and left tabs of the hood exhaust louver to remove.
6. Now, the hood exhaust louver is free.

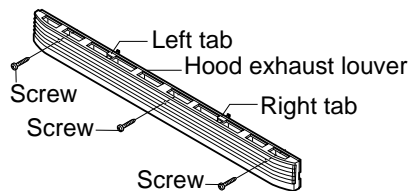

REMOVAL OF OVEN FROM WALL (Two persons recommended to remove the oven)

1. Disconnect the power supply cord, and uncoil the power supply cord.
2. To discharge the high voltage capacitor, wait for 60 seconds.
3. Remove the turntable tray and support from the oven cavity.
4. If the exhaust damper assembly is installed, remove the one (1) screw holding the exhaust damper assembly to the rear stay, and remove the exhaust damper assembly by sliding it backward.
5. Remove the two (2) screws holding the oven (outer case cabinet) to the top cabinet.
6. While supporting the front of the oven, pull down the two (2) mounting levers and release the oven from the unit mounting plate.
7. Pull the power cord out of the wall cabinet and remove the oven.
8. The oven is now free and can be placed on the work surface selected for servicing the oven.
9. Installation is the reverse of this procedure.

OUTER CASE REMOVAL

Remove the oven from the wall, referring to "REMOVAL OF OVEN FROM WALL" and proceed as follows;

1. Disconnect the power supply cord.
2. Open the door and block it open.
3. To discharge the high voltage capacitor, wait for 60 seconds.
4. Remove four (4) screws holding the rear stay to the hood fan motor or the oven, and remove it.
5. Remove the six (6) screws from the rear of the outer case cabinet and one (1) screw at front.
6. Slide the outer case cabinet back about 1 inch (3 cm) to free it from retaining clips on the cavity face plate.
7. Disconnect the three (3) pin connector of the power

supply cord from the wiring harness and remove the power supply cord together with the outer case.

8. Nip the cord bushing with bushing pliers and release it from the outer case cabinet.
9. Remove the cord bushing and the power supply cord from the outer case cabinet.
10. Now, the power supply cord is free.

CAUTION: 1. DISCONNECT OVEN FROM POWER SUPPLY BEFORE REMOVING OUTER CASE.
2. DISCHARGE THE HIGH VOLTAGE CAPACITOR BEFORE TOUCHING ANY OVEN COMPONENTS OR WIRING.

POWER TRANSFORMER REMOVAL

1. Disconnect the power supply cord, remove the oven from wall, and remove outer case. (Refer to procedure of "REMOVAL OF OVEN FROM WALL" AND "OUTER CASE REMOVAL".) And proceed as follows.
2. Open the door and block it open.
3. To discharge the high voltage capacitor, wait for 60 seconds.
4. Remove three (3) screws holding the hood intake duct R to the oven cavity top plate, the oven cavity front flange and the fan duct. And remove the hood intake duct R.
5. Disconnect main wire harness from transformer.
6. Disconnect high voltage wire A from the transformer.
7. Disconnect filament leads of transformer from the magnetron and capacitor.
8. Remove two (2) screws holding the transformer to base plate R.

Re-install

1. Install by sliding the transformer on the base plate R with its primary terminals toward the outer case.
2. Secure the transformer with two (2) screws to base plate R.
3. Re-connect wire leads (primary and high voltage) to the transformer and filament leads of transformer to magnetron and high voltage capacitor. Refer to "PICTORIAL DIAGRAM".
4. Re-install the hood intake duct R to the oven cavity top plate, the oven cavity front flange and the fan duct with three (3) screws.
5. Re-install the outer case and check that oven is operating properly.

CAUTION: MAKE SURE THE WIRE LEADS NEVER TOUCH THE FAN BLADE.

HOOD FAN MOTOR REMOVAL

1. Disconnect the power supply cord and remove the oven from wall and remove outer case. (Refer to procedure of "Removal of Oven from Wall" and "Outer case Removal")
2. Open the door and block it open.
3. To discharge the high voltage capacitor, wait for 60 seconds.

4. Disconnect the 6-pin connector of the hood fan motor from the main wire harness located at the right edge of the oven cavity top plate and release the snap band from the hood duct.
5. Remove the hood fan motor from the oven cavity top plate by lifting it up.
6. Now, the hood fan motor is free.

MAGNETRON REMOVAL

1. Disconnect the power supply cord, remove the oven from wall and remove outer case (Refer to procedure of "Removal of Oven from Wall" and "Outer case Removal".)
 2. Open the door and block it open.
 3. To discharge the high voltage capacitor, wait for 60 seconds.
 4. Remove the three (3) screws holding the hood intake duct R to the oven cavity top plate, the oven cavity front flange and the fan duct. And remove the hood intake duct R.
 5. Disconnect the high voltage wire lead of the high voltage rectifier assembly from the magnetron.
 6. Disconnect the filament lead of the transformer from the magnetron.
 7. Remove the one (1) screw holding the hood duct R to the oven cavity top plate. And remove the hood duct R from the oven cavity top plate R.
 8. Remove the magnetron duct from the oven cavity, by releasing the tab of the magnetron duct from the oven cavity top plate.
 9. Carefully remove four (4) mounting screws holding the magnetron to waveguide. When removing the screws hold the magnetron to prevent it from falling.
 10. Remove the magnetron from the unit with care so the magnetron tube should not be hit by any metal object around the tube.
- CAUTION: WHEN REPLACING THE MAGNETRON, BE SURE THE R.F. GASKET IS IN PLACE AND MOUNTING SCREWS ARE TIGHTENED SECURELY.

HIGH VOLTAGE RECTIFIER AND HIGH VOLTAGE CAPACITOR REMOVAL

1. Disconnect the power supply cord, remove the oven from wall and remove outer case (Refer to procedure of "Removal of Oven from Wall" and "Outer case Removal".)
 2. Open the door and block it open.
 3. To discharge the high voltage capacitor, wait for 60 seconds.
 4. Remove the three (3) screws holding the hood intake duct R to the oven cavity top plate, the oven cavity front flange and the fan duct. And remove the hood intake duct R.
 5. Disconnect the high voltage wire lead with high voltage rectifier from the magnetron.
 6. Disconnect filament lead of the transformer from high voltage capacitor.
 7. Disconnect high voltage wire A from capacitor.
 8. Remove the fan duct assembly from the oven cavity, referring to the procedure of "COOLING FAN MOTOR REMOVAL"
 9. Remove one (1) screw holding capacitor holder and high voltage rectifier to the fan duct.
 10. Disconnect the high voltage rectifier assembly from the high voltage capacitor.
 11. Now, the high voltage rectifier assembly is free.
 12. Remove capacitor from the holder.
 13. Now, the high voltage capacitor is free.
- CAUTION: WHEN REPLACING THE HIGH VOLTAGE RECTIFIER ASSEMBLY, THE GROUND SIDE TERMINAL MUST BE SECURED FIRMLY WITH A GROUNDING SCREW.

HOOD FAN THERMAL CUT-OUT REMOVAL

1. Disconnect the power supply cord and remove the oven from wall and remove outer case. (Refer to procedure of "Removal of Oven from Wall" and "Outer case Removal")
2. Open the door and block it open.
3. To discharge the high voltage capacitor, wait for 60 seconds.
4. Remove the three (3) screws holding the hood intake duct R to the oven cavity top plate, the oven cavity front flange and the fan duct. And remove the hood intake duct R.
5. Disconnect the wire leads from the hood fan thermal cut-out.
6. Remove one (1) screw holding the thermal cut-out to the flange of base plate R (turntable motor side).
7. Remove the hood fan thermal cut-out from the base plate R.
8. Now, the hood fan thermal cut-out is free.

THERMAL CUT-OUT (CAVITY) REMOVAL

1. Disconnect the power supply cord and remove the oven from wall and remove outer case. (Refer to procedure of "Removal of Oven from Wall" and "Outer case Removal")
2. Open the door and block it open.
3. To discharge the high voltage capacitor, wait for 60 seconds.
4. Disconnect the wire leads from the thermal cut-out (cavity).
5. Remove the thermal cut-out (cavity) from the holder at the oven cavity bottom plate.
6. Now, the thermal cut-out (cavity) is free.

TEMPERATURE FUSE (MAGNETRON) REMOVAL

1. Disconnect the power supply cord and remove the oven from wall and remove outer case. (Refer to procedure of "Removal of Oven from Wall" and "Outer case Removal")
2. Open the door and block it open.
3. To discharge the high voltage capacitor, wait for 60 seconds.
4. Remove the fan duct assembly from the oven cavity,

referring to the procedure of " COOLING FAN MOTOR REMOVAL".

5. Disconnect the wire leads from the temperature fuse (Magnetron).
6. Remove the one (1) screw holding the temperature fuse (Magnetron) to the fan duct.
7. Now, the temperature fuse (Magnetron) is free.

COOLING FAN MOTOR REMOVAL

1. Disconnect the power supply cord, remove the oven from wall and remove outer case (Refer to procedure of "Removal of Oven from Wall" and "Outer case Removal".)
2. Open the door and block it open.
3. To discharge the high voltage capacitor, wait for 60 seconds.
4. Remove the three (3) screws holding the hood intake duct R to the oven cavity top plate, the oven cavity front flange and the fan duct. And remove the hood intake duct R.
5. Remove the one (1) screw holding the hood duct R to the oven cavity top plate. And remove the hood duct R.
6. Disconnect the wire leads from the fan motor.
7. Disconnect the high voltage wire lead with the high voltage rectifier from the magnetron.
8. Disconnect the filament lead of the transformer from the high voltage capacitor.
9. Disconnect the high voltage wire A from the capacitor.
10. Release the wire leads from the hole of the fan duct.
11. Remove two (2) screws holding the fan duct to oven cavity top plate and the base plate R.
12. Remove the fan duct assembly from the oven cavity.
13. Remove the fan blade from the fan motor shaft according the following procedure.
14. Hold the edge of the rotor of the fan motor by using a pair of groove joint pliers.

CAUTION:

- * **Make sure that any pieces do not enter the gap between the rotor and the stator of the fan motor because the rotor is easily shaven by pliers and metal pieces may be produced.**
- * **Do not touch the pliers to the coil of the fan motor because the coil may be cut or damaged.**
- * **Do not disfigure the bracket by touching with the pliers.**

15. Remove the fan blade from the shaft of the fan motor by pulling and rotating the fan blade with your hand.
16. Now, the fan blade will be free.

CAUTION:

- * **Do not reuse the removed fan blade because the hole (for shaft) may be larger than normal.**
17. Remove the two (2) screws holding the fan motor to the fan duct.
 18. Now, the fan motor is free.

INSTALLATION

1. Install the fan blade to the fan motor shaft according to the following procedure.
2. Hold the center of the bracket which supports the shaft of the fan motor on the flat table.
3. Install the fan blade to the shaft of fan motor by pushing the fan blade with a small, light weight, ball peen hammer or rubber mallet.
4. Install the fan motor to the hood duct with the two (2) screws.

CAUTION:

- * **Do not hit the fan blade with excessive force when installing because the bracket may be disfigured.**
 - * **Make sure that the fan blade rotates smooth after installation.**
 - * **Make sure that the axis of the shaft is not slanted.**
5. Install the fan duct to the oven cavity top plate and base plate R with the two (2) screws.
 6. Reconnect the wire leads to the fan motor, magnetron and high voltage capacitor, referring to the pictorial diagram.
 7. Re-install the wire leads to the hole of the fan duct.
 8. Re-install the hood intake duct R to the oven cavity top plate, the oven cavity front flange and the fan duct with the three (3) screws.
 9. Refer to procedure of "OUTER CASE REMOVAL". And reverse their procedure. And re-install the outer case.

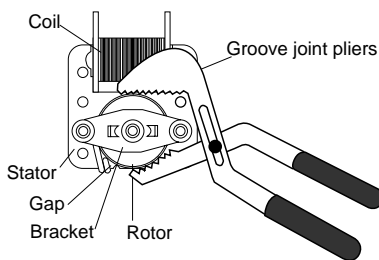

Rear View

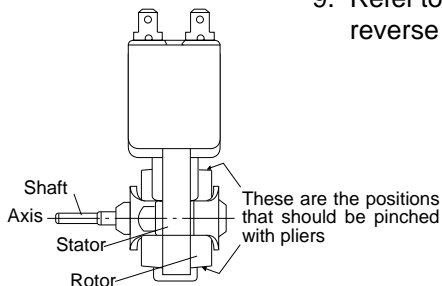

Side View

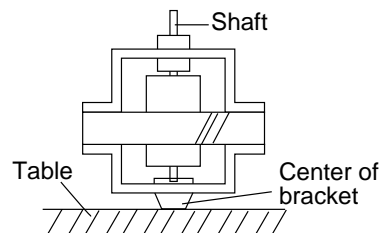

TURNTABLE MOTOR AND FOOD LAMP SOCKETS REMOVAL

1. Disconnect the power supply cord.
2. Open the door and block it open.
3. To discharge the high voltage capacitor, wait for 60 seconds.
4. Remove the one (1) screw holding the base cover to the oven cavity back plate.
5. Remove the three (3) screws holding the base cover to the oven cavity front face plate.
6. Open the base cover.
7. Release the two hood lamp sockets from the base cover.
8. Remove the base cover from the oven cavity by pulling down and moving to the left slightly.

TURNTABLE MOTOR

9. Disconnect the wire leads from the turntable motor.
10. Remove one (1) screw holding turntable motor to the oven cavity.
11. Now the turntable motor is free.

HOOD LAMP SOCKET

9. Screw the hood lamp off from the lamp socket.
10. Disconnect the wire leads from the lamp socket by pushing the terminal hole of the lamp socket with the small flat type screw driver.
11. Now, the lamp socket is free.

OVEN LAMP AND LAMP SOCKET REMOVAL

1. Disconnect the power supply cord.
2. Open the door and block it open.
3. Remove three (3) screws holding the hood exhaust louver to oven cavity front face plate.
4. Remove the hood exhaust louver from the oven by pushing the right and left tabs of the hood exhaust louver. (Refer to procedure of "HOOD EXHAUST LOUVER REMOVAL")
5. Remove one (1) screw holding the control panel to the oven cavity front face plate.
6. Release the control panel from the oven cavity front face plate by lifting it up and tilting top edge back.
7. Turn the lamp socket and release it from the magnetron duct.
8. Screw the oven lamp off from the lamp socket.
9. Now, the oven lamp is free.

10. Pull the wire leads from the oven lamp socket by pushing the terminal hole of the oven lamp socket with the small flat type screw driver.
11. Now, the oven lamp socket is free.

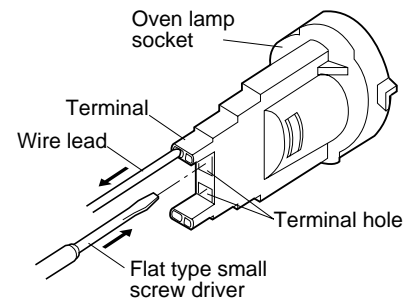

POSITIVE LOCK® CONNECTOR (NO-CASE TYPE) REMOVAL

1. Disconnect the power supply cord and remove the oven from wall and remove outer case. (Refer to procedure of "Removal of Oven from Wall" and "Outer case Removal")
2. Open the door and block it open.
3. To discharge the high voltage capacitor, wait for 60 seconds.
4. Push the lever of positive lock® connector.
5. Pull down on the positive lock® connector.

CAUTION: WHEN CONNECTING THE POSITIVE LOCK® CONNECTORS TO THE TERMINALS, INSTALL THE POSITIVE LOCK® SO THAT THE LEVER FACES YOU.

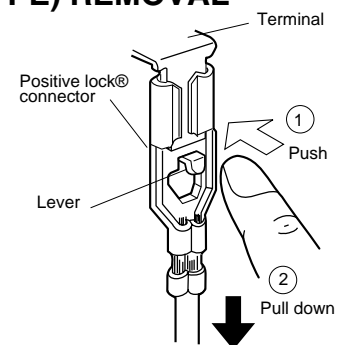

Positive lock® connector

CONTROL PANEL ASSEMBLY, CONTROL UNIT AND KEY UNIT REMOVAL

1. Disconnect the power supply cord.
2. Open the door and block it open.
3. To discharge the high voltage capacitor, wait for 60 seconds.
4. Remove three (3) screws holding the hood exhaust louver to oven cavity front face plate.
5. Remove the hood exhaust louver from the oven by pushing the right and left tabs of the hood exhaust louver. (Refer to procedure of "HOOD EXHAUST LOUVER REMOVAL")

6. Remove one (1) screw holding the control panel to the oven cavity front face plate.
7. Release the control panel from the oven cavity front face plate by lifting it up.
8. Disconnect the wire leads from the relays RY1 and RY2.
9. Disconnect the connectors CN-A, CN-B and CN-E from the control unit.
10. Remove the control panel assembly from the oven.
11. Now, the control panel assembly is free.
12. Disconnect the connector CN-G from the control unit.

13. Remove the two (2) screws holding the LCD holder to the key fixing plate.
14. Remove two (2) screws holding the power unit to the key fixing plate.
15. Release the two (2) tabs holding the power unit to the key fixing plate.
16. Release the three (3) tabs holding the LCD to the LCD holder.
17. Release the two (2) tabs holding the LSI unit to the LCD holder.
18. Remove the LCD holder and the LED sheet.
19. Now, the control unit is free.
20. Remove the one (1) screw holding the key fixing plate to the control panel.
21. Release the six (6) tabs holding the key fixing plate to the control panel.
22. Remove the key fixing plate from the control panel.
23. Remove the key unit from the key fixing plate.
24. Now, the key unit is free

NOTES FOR KEY UNIT REPLACEMENT

1. Do not reuse the torn key unit because the performance of the adhesive becomes weak.

2. Before attaching a new key unit, wipe off remaining adhesive on the key fixing plate surfaces completely with a soft cloth soaked in alcohol.
3. When attaching the key unit to the key fixing plate, adjust the upper edge and right edge of the key unit to the correct position of key fixing plate. See key unit location.
4. Stick the key unit firmly to the key fixing plate by rubbing with soft cloth not to scratch.

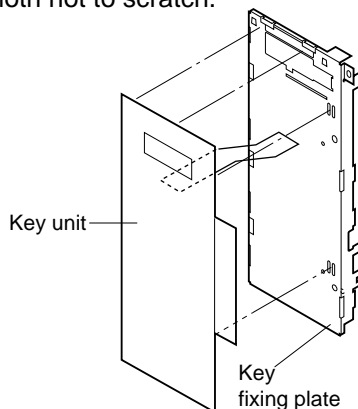

Key unit location

DOOR SENSING SWITCH, PRIMARY INTERLOCK SWITCH AND MONITOR SWITCH REMOVAL

1. Disconnect the power supply cord and remove the oven from wall and remove outer case. (Refer to procedure of "Removal of Oven from Wall" and "Outer case Removal")
2. Open the door and block it open.
3. To discharge the high voltage capacitor, wait for 60 seconds.
4. Remove the three (3) screws holding the hood intake duct R to the oven cavity top plate, the oven cavity front flange and the fan duct. And remove the hood intake duct R.
5. Remove the control panel assembly, referring to the procedure of "CONTROL PANEL ASSEMBLY , CONTROL UNIT AND KEY UNIT REMOVAL".
6. Remove the two (2) screws holding the latch hook to the oven cavity front flange.
7. Remove the latch hook from the oven cavity front flange.
8. Disconnect the wire leads of each switch.

9. Remove each switch from the latch hook by pushing the one (1) stopper tab holding each switch.
10. Now, each switch is free.

Re-install

1. Re-install each switch in its place. The primary interlock switch is in the lower position, door sensing switch is in the upper position and the monitor switch is in the middle position.
2. Re-connect wire leads to each switch. Refer to pictorial diagram.
3. Secure the latch hook (with two (2) mounting screws) to oven cavity front flange.
4. Make sure that the monitor switch is operating properly and check continuity of the monitor circuit. Refer to chapter "Test Procedure" and "Adjustment procedure".

DOOR SENSING SWITCH, PRIMARY INTERLOCK SWITCH AND MONITOR SWITCH ADJUSTMENT

1. Disconnect the power supply cord and remove the oven from wall and remove outer case. (Refer to procedure of "Removal of Oven from Wall" and "Outer case Removal")
2. Open the door and block it open.
3. To discharge the high voltage capacitor, wait for 60 seconds.
4. Remove the three (3) screws holding the hood intake duct R to the oven cavity top plate, the oven cavity front flange and the fan duct. And remove the hood intake duct R.
5. Remove the control panel assembly, referring to the procedure of "CONTROL PANEL ASSEMBLY , CONTROL UNIT AND KEY UNIT REMOVAL".

If the door sensing switch, primary interlock switch and monitor switch do not operate properly due to a misadjustment, the following adjustment should be made.

6. Loosen the two (2) screws holding latch hook to the oven cavity front flange.
7. With door closed, adjust latch hook by moving it back and forth, and up and down. In and out play of the door allowed by the upper and lower position of the latch hook should be less than 0.5mm. The vertical position of the latch hook should be adjusted so that the door sensing switch and primary interlock switch are activated with the door closed. The horizontal position of the latch hook should be adjusted so that the monitor switch is activated with the door closed.
8. Secure the screws with washers firmly.
9. Check all of the switches operation. If any switch has not activated with the door closed, loosen screw and adjust the latch hook position.

After adjustment, check the following.

1. In and out play of door remains less than 0.5mm when in the latched position. First check upper position of latch hook, pushing and pulling upper portion of door toward the oven face. Then check lower portion of the latch hook, pushing and pulling lower portion of the door toward the oven face. Both results (play in the door) should be less than 0.5mm.
2. The door sensing switch and primary interlock switch interrupt the circuit before the door can be opened.
3. Monitor switch contacts close when door is opened.
4. Re-install outer case and check for microwave leakage around door with an approved microwave survey meter. (Refer to Microwave Measurement Procedure.)

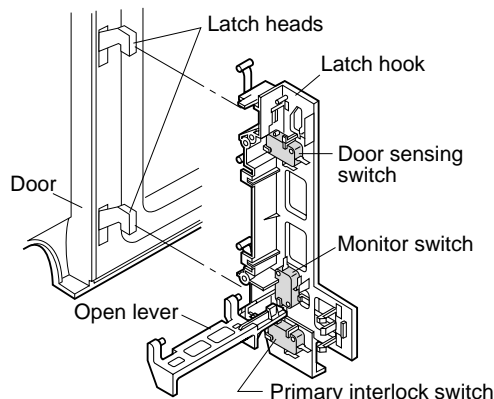

Figure C-1. Latch Switch Adjustments

DOOR REPLACEMENT

DOOR ASSEMBLY REMOVAL

1. Disconnect the power supply cord.
2. Open the door and block it open.
3. To discharge the high voltage capacitor, wait for 60 seconds.
4. Remove the three (3) screws holding the hood exhaust louver to the oven cavity front face plate.
5. Remove the hood exhaust louver from the oven cavity by pushing the right and left tabs of the hood exhaust louver. (Refer to the procedure of "HOOD EXHAUST LOUVER REMOVAL".)
6. Insert a putty knife (thickness of about 0.5mm) into the gap (A) between the door stopper and the choke cover as shown in Figure C-3 to free engaging parts.
7. Lift up the door stopper.
8. Now, the door stopper is free from the door assembly.
9. Lift up the door assembly to release the upper and lower door hinge pins from the upper and lower oven hinges.
10. Now, the door assembly is free.

Note: When the individual parts are replaced, refer to "Door Disassembly".

DOOR ASSEMBLY RE-INSTALL

1. On re-installing door, insert the lower oven hinge to lower door hinge pin.
2. Insert the upper oven hinge to the upper door hinge pin.
3. Shut the door (close the contacts of interlock switches).
4. Make sure upper and lower oven hinges are inserted into the upper and lower door hinge pins.
5. Make sure the door is parallel with oven face lines (left and upper side lines) and door latch heads pass through latch holes correctly.
6. Re-install the door stopper to the door assembly.
7. Re-install the hood exhaust louver to the oven cavity front face plate with the three (3) screws.

Note: After any service to the door;

- (A) Make sure that door sensing switch and primary interlock switch are operating properly. (Refer to chapter "Test Procedures".)
- (B) An approved microwave survey meter should be used to assure compliance with proper microwave radiation emission limitation standards.

After any servicing, make sure of the following :

1. Door latch heads smoothly catch latch hook through latch holes and that latch head goes through center of latch hole.
2. Deviation of door alignment from horizontal line of cavity face plate is to be less than 1.0mm.
3. Door is positioned with its face pressed toward cavity face plate.
4. Re-install outer case and check for microwave leakage around door with an approved microwave survey meter. (Refer to Microwave Measurement Procedure.)

Note: The door on a microwave oven is designed to act as an electronic seal preventing the leakage of microwave energy from oven cavity during cook cycle. This function does not require that door be air-tight, moisture (condensation)-tight or light-tight. Therefore, occasional appearance of moisture, light or sensing of gentle warm air movement around oven door is not abnormal and do not of themselves indicate a leakage of microwave energy from oven cavity.

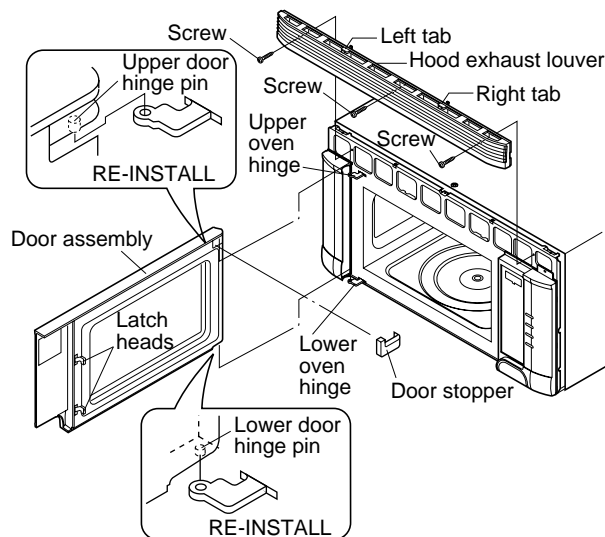

Figure C-2. Door Replacement and adjustment

DOOR DISASSEMBLY

1. Disconnect the power supply cord.
2. Open the door and block it open.
3. To discharge the high voltage capacitor, wait for 60 seconds.
4. Remove the three (3) screws holding the hood exhaust louver to the oven cavity front face plate.
5. Remove the hood exhaust louver from the oven cavity by pushing the right and left tabs of the hood exhaust louver. (Refer to the procedure of "HOOD EXHAUST LOUVER REMOVAL".)
6. Remove door assembly, referring to "DOOR REPLACEMENT".

Replacement of door components are as follows:

7. Place door assembly on a soft cloth with latches facing up.

Note: As the engaging part of choke cover and door frame are provided at 15 places, do not force any particular part.

CHOKE COVER

8. Insert a putty knife (thickness of about 0.5mm) into the gap (A) between the choke cover and door stopper and between the choke cover and the door frame as shown Figure C-3 to free engaging parts.
9. Pry the choke cover by inserting a putty knife in order shown in Figure C-3.
10. Now choke cover is free from door panel and door frame.

NOTE: When carrying out any repair to the door, do not bend or warp the slit choke (tabs on the door panel assembly) to prevent microwave leakage.

DOOR FRAME ASSEMBLY

11. Remove two (2) screws holding the door panel to the door frame assembly.
 12. Release the door panel from the door frame assembly.
- NOTE: It is easier to release the engaging parts of the upper or lower door hinge pin side at first.
13. Now, door frame assembly is free.

LATCH SPRING, LATCH HEAD AND DOOR PANEL

14. Release the latch spring from the tab of the latch head and tab of the door frame.
15. Release the latch head from the door frame.
16. Now, the latch spring and latch head are free.

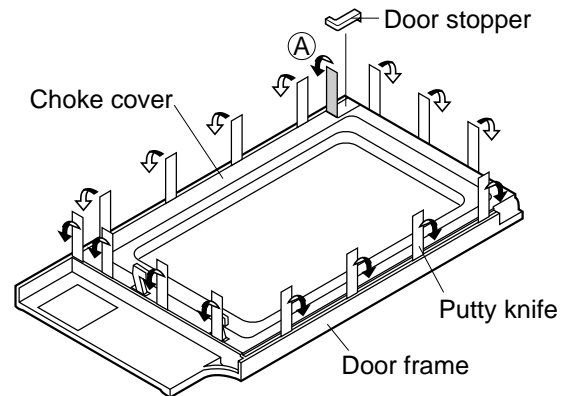

Figure C-3. Door Disassembly

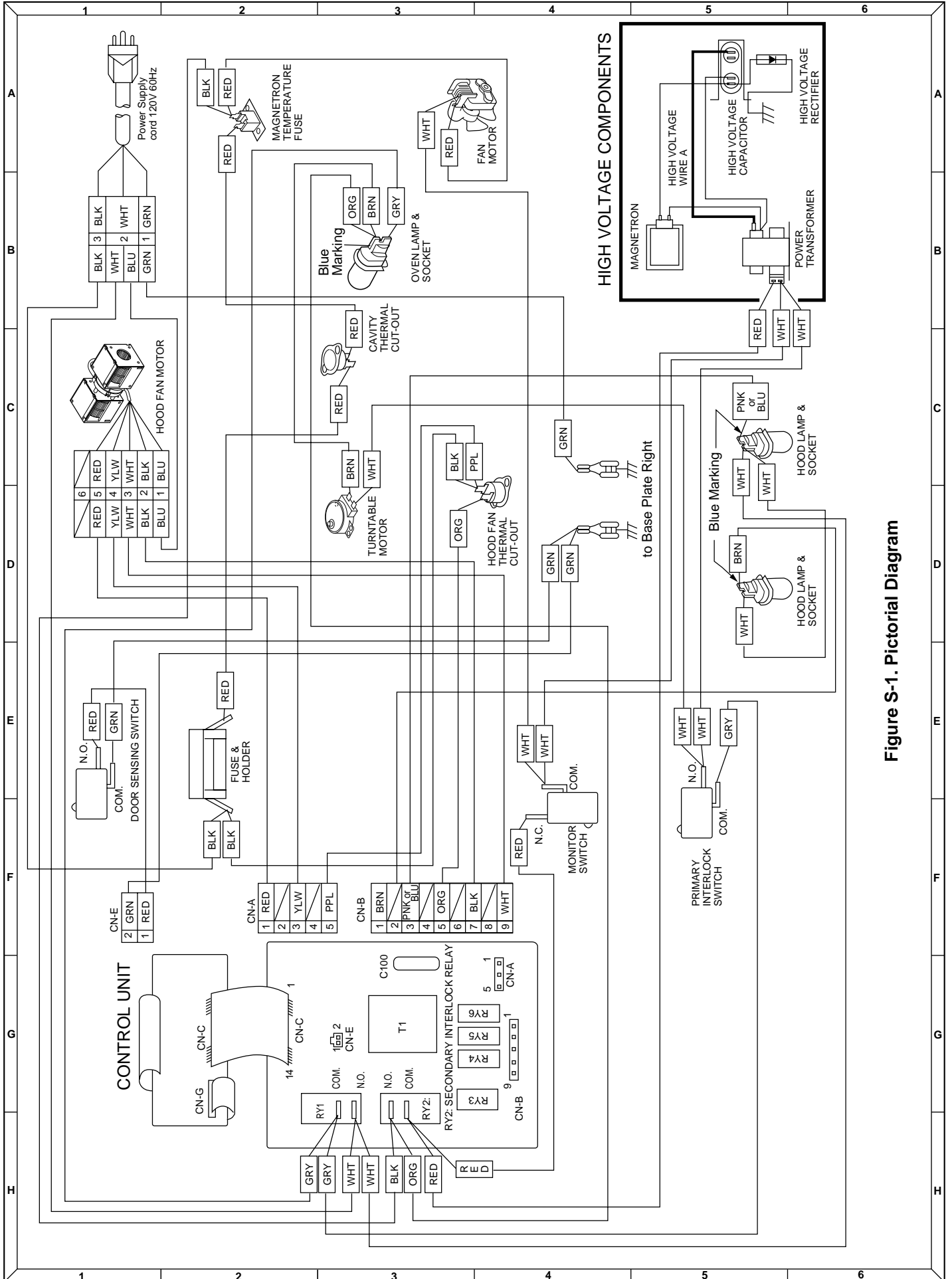

Figure S-1. Pictorial Diagram

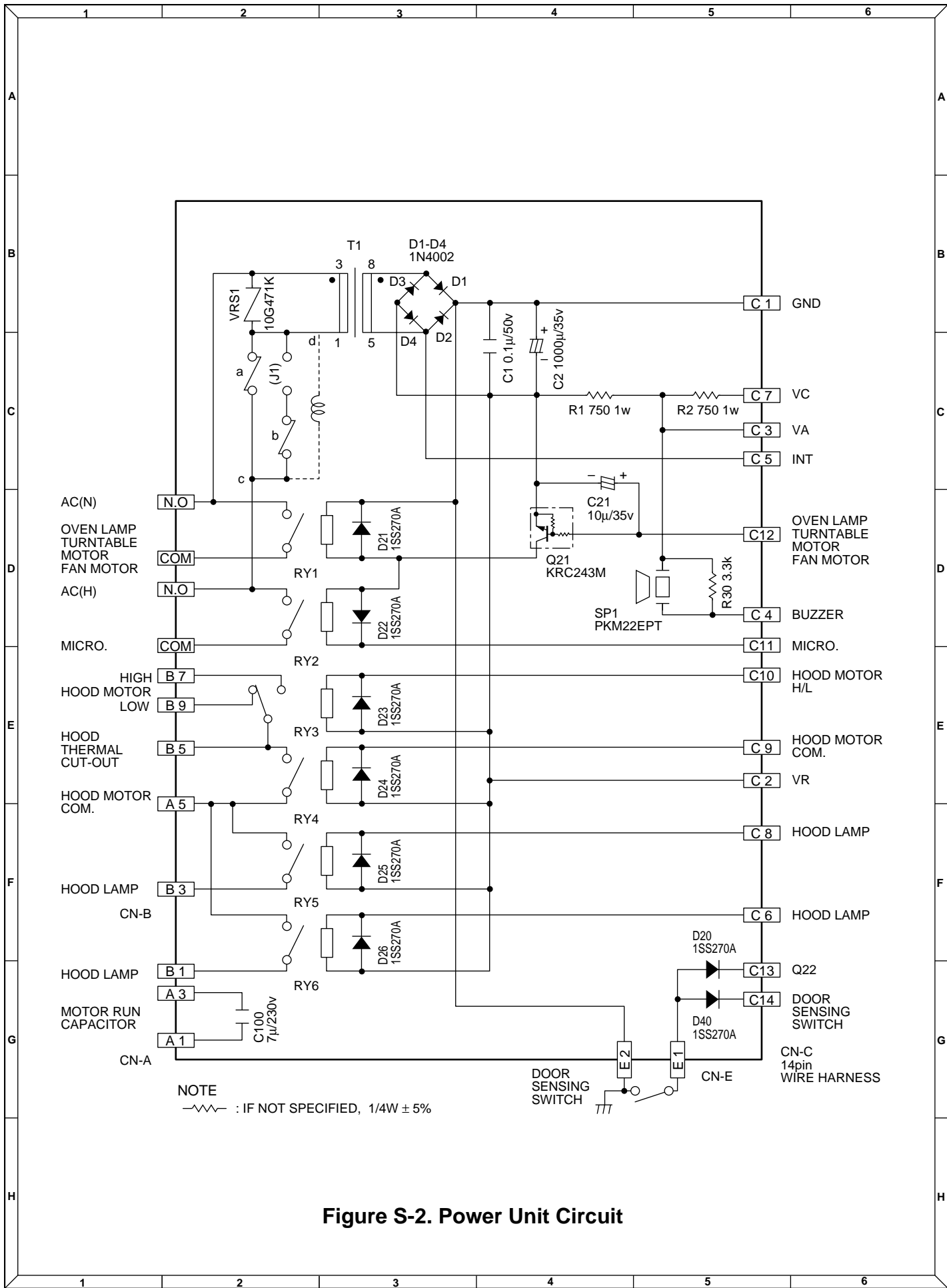

Figure S-2. Power Unit Circuit

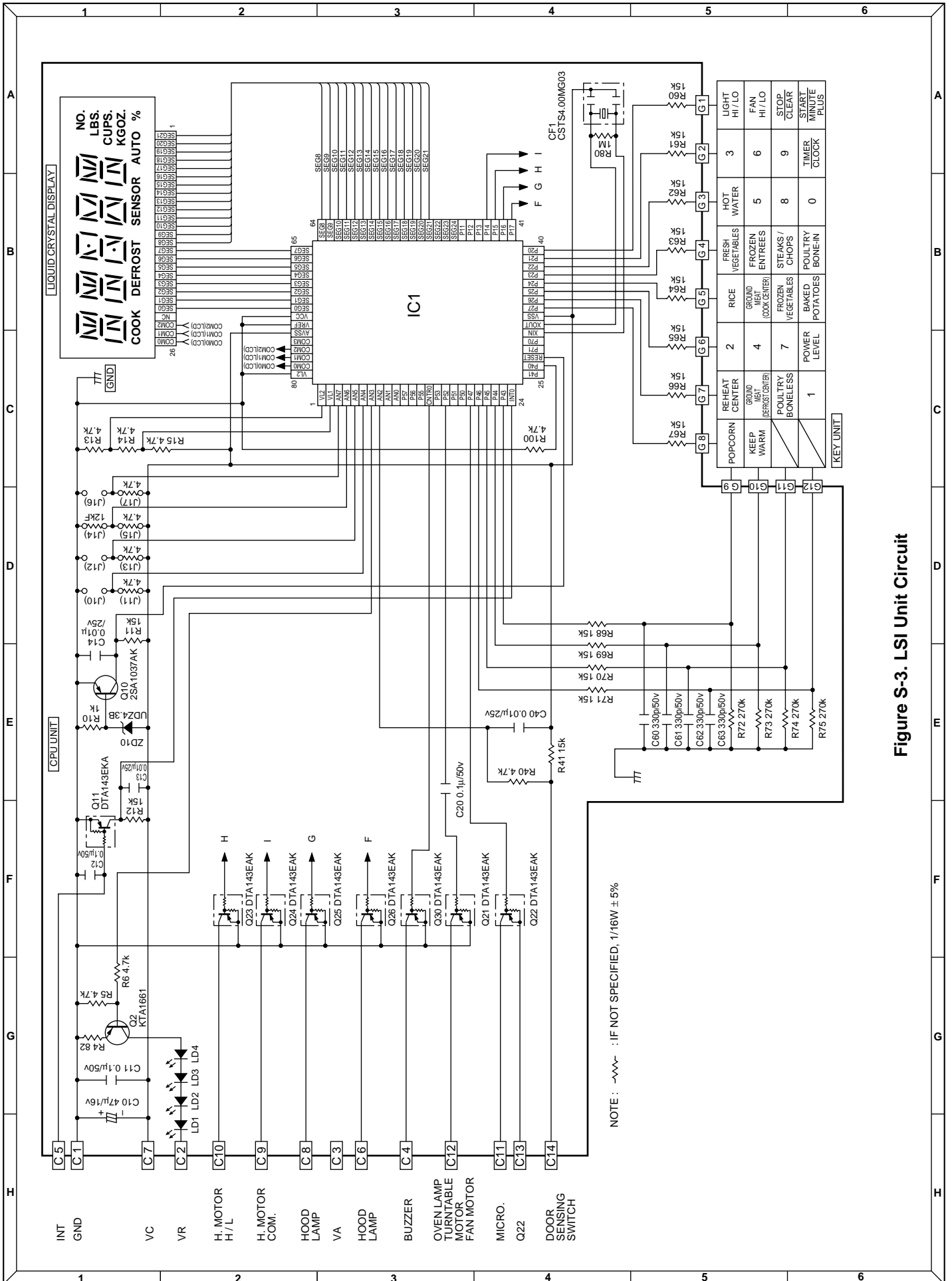

Figure S-3. LSI Unit Circuit

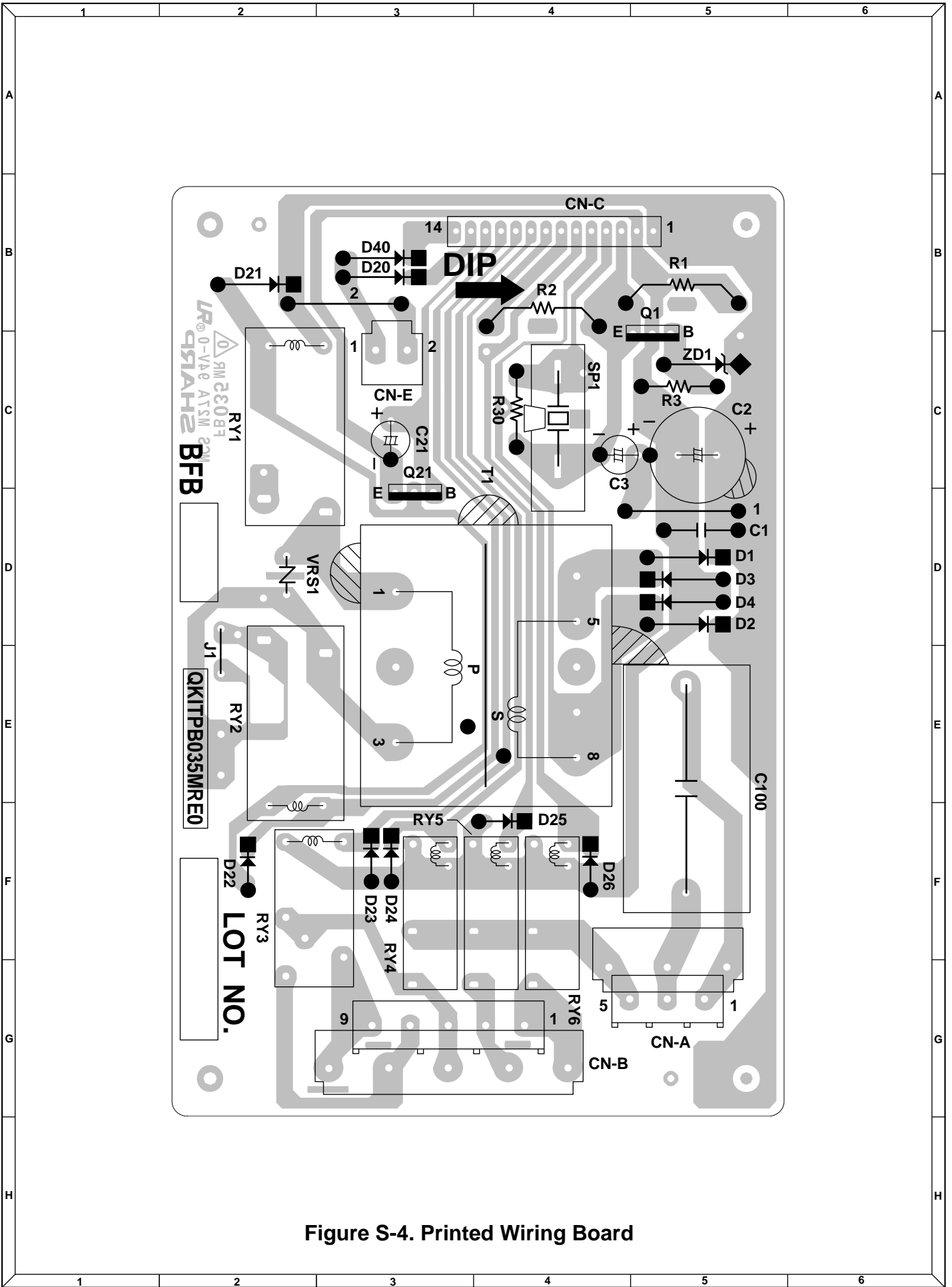

Figure S-4. Printed Wiring Board

PARTS LIST

**Note: The parts marked "Δ" may cause undue microwave exposure.
The parts marked "*" are used in voltage more than 250V.**

"§" MARK: PARTS DELIVERY SECTION

REF. NO.	PART NO.	§	DESCRIPTION	Q'TY	CODE
ELECTRIC PARTS					
* 1- 1	FH-DZB016MRY0	M	High voltage rectifier assembly	1	AH
* 1- 2	RC-QZA234WRE0	M	High voltage capacitor	1	AP
1- 3	QFS-TA013WRE0	M	Temperature fuse 150°C (Magnetron)	1	AE
1- 4	RMOTDA211WRE0	M	Turntable motor	1	AL
1- 5	RTHM-A070WRE0	M	Thermal cut-out 145°C (Cavity)	1	AF
1- 6	RTHM-0044MRE0	M	Thermal cut-out N.O. 60°C (Hood Fan)	1	AH
* 1- 7	RTRN-B068MRE0	M	Power transformer	1	BC
Δ* 1- 8	RV-MZA288WRE0	M	Magnetron	1	BK
1- 9	QFSHDB003MRE0	M	Fuse holder	1	AD
1-10	QSW-MA085WRE0	M	Primary interlock and door sensing switches	2	AE
1-11	FFS-BA016/KIT	M	Monitor switch (V-16G-2C25) with fuse (20A) assembly	1	AF
1-12	FACCDB011MRE0	M	Power supply cord	1	AQ
1-13	QSOCLB006MRE0	M	Oven lamp socket	3	AE
1-14	FMOTEA441WRKZ	M	Hood fan motor	1	BC
1-15	RMOTEA406WRZZ	M	Fan motor	1	AT
1-16	RLMPTA068WRE0	M	Oven lamp	3	AE

CABINET PARTS

2- 1	LSTY-B024MRP0	M	Rear stay	1	AE
2- 2	PDIF-B030MRF0	M	Hood exhaust louver [R-1500]	1	AQ
2- 2	PDIF-B031MRF0	M	Hood exhaust louver [R-1501]	1	AQ
2- 2	PDIF-B030MRF0	M	Hood exhaust louver [R-1505]	1	AQ
2- 2	PDIF-B031MRF0	M	Hood exhaust louver [R-1506]	1	AQ
2- 3	GDAI-B065MRP0A	M	Base plate R	1	AG
2- 4	HDECQB027MRF0	M	Front panel L [R-1500]	1	AL
2- 4	HDECQB028MRF0	M	Front panel L [R-1501]	1	AL
2- 4	HDECQB027MRF0	M	Front panel L [R-1505]	1	AL
2- 4	HDECQB028MRF0	M	Front panel L [R-1506]	1	AL
2- 5	GCABUB103MRP0	M	Outer case cabinet [R-1500]	1	AZ
2- 5	GCABUB105MRP0	M	Outer case cabinet [R-1501]	1	AZ
2- 5	GCABUB103MRP0	M	Outer case cabinet [R-1505]	1	AZ
2- 5	GCABUB105MRP0	M	Outer case cabinet [R-1506]	1	AZ
2- 6	TMAPCB067MRR0	M	Schematic diagram	1	AB
2- 7	FANGKB009MRY0	M	Hood lamp glass assembly [R-1500]	1	AN
2- 7	FANGKB010MRY0	M	Hood lamp glass assembly [R-1501]	1	AM
2- 7	FANGKB009MRY0	M	Hood lamp glass assembly [R-1505]	1	AN
2- 7	FANGKB010MRY0	M	Hood lamp glass assembly [R-1506]	1	AM
2-7-1	LANGQB016MRP0	M	Hood lamp glass angle [R-1500]	1	AG
2-7-1	LANGQB020MRP0	M	Hood lamp glass angle [R-1501]	1	AG
2-7-1	LANGQB016MRP0	M	Hood lamp glass angle [R-1505]	1	AG
2-7-1	LANGQB020MRP0	M	Hood lamp glass angle [R-1506]	1	AG
2-7-2	PGLSPB004MRE0	M	Hood lamp glass	1	AH
2- 8	PCOVVPB096MRT0	M	Base cover [R-1500]	1	AV
2- 8	PCOVVPB097MRT0	M	Base cover [R-1501]	1	AV
2- 8	PCOVVPB096MRT0	M	Base cover [R-1505]	1	AV
2- 8	PCOVVPB097MRT0	M	Base cover [R-1506]	1	AV

CONTROL PANEL PARTS

3- 1	CPWFBF060MRU0	M	Control unit	1	BF
3- 1A	QCNCMA017JDZZ	M	3-pin connector CN-A	1	AA
3- 1B	QCNCMA448DRE0	M	5-pin connector CN-B	1	AA
3- 1C	QCNCMA275DRE0	J	2-pin connector CN-E	1	AB
3- 1D	FW-VZB189MRE0	M	Lead wire harness CN-C	1	AB
C1	RC-KZA087DRE0	J	Capacitor 0.1 uF 50V	1	AB
C2	VCEAB31VW108M	J	Capacitor 1000 uF 35V	1	AF
C21	VCEAB31VW106M	J	Capacitor 10 uF 35V	1	AB
C100	RC-QZB014MRE0	M	Capacitor 7 uF 230V	1	AK
D1-4	RH-DZA006PRE0	J	Diode (1N4002)	4	AD
D20-26	VHD1SS270A/-1	J	Diode (1SS270A)	7	AA
D40	VHD1SS270A/-1	J	Diode (1SS270A)	1	AA
Q21	VSKRC243M/-3	J	Transistor (KRC243M)	1	AB
R1-2	VRS-B13AA751J	J	Resistor 750 ohm 1W	2	AB
R30	VRD-B12EF332J	J	Resistor 3.3k ohm 1/4W	1	AA
RY1-2	RRLY-A113DRE0	M	Relay (DU24D1-1PR(M))	2	AG
RY3	RRLY-A123DRZZ	M	Relay (G5S-1 24V)	1	AG
RY4-6	RRLY-B004MRE0	M	Relay (FTR-F3AA024E)	3	AG

REF. NO.	PART NO.	§	DESCRIPTION	Q'TY	CODE
SP1	RALM-A014DRE0	J	Buzzer (PKM22EPT)	1	AG
T1	RTRNPB017MRE0	M	Transformer	1	BG
VRS1	RH-VZA032DRE0	J	Varistor (10G471K)	1	AE
3- 2	FPNLCB372MRK0	M	Control panel sub. assembly [R-1500]	1	AZ
3- 2	FPNLCB373MRK0	M	Control panel sub, assembly [R-1501]	1	AZ
3- 2	FPNLCB372MRK0	M	Control panel sub. assembly [R-1505]	1	AZ
3- 2	FPNLCB373MRK0	M	Control panel sub, assembly [R-1506]	1	AZ
3- 2-1	FUNTKB320MRE0	M	Key unit [R-1500]	1	AQ
3- 2-1	FUNTKB321MRE0	M	Key unit [R-1501]	1	AQ
3- 2-1	FUNTKB320MRE0	M	Key unit [R-1505]	1	AQ
3- 2-1	FUNTKB321MRE0	M	Key unit [R-1506]	1	AQ
3- 2-2	JBTN-B106MRF0	M	Open button [R-1500]	1	AE
3- 2-2	JBTN-B108MRF0	M	Open button [R-1501]	1	AE
3- 2-2	JBTN-B106MRF0	M	Open button [R-1505]	1	AE
3- 2-2	JBTN-B108MRF0	M	Open button [R-1506]	1	AE
3- 2-3	JBTN-B107MRF0	M	Select button [R-1500]	1	AC
3- 2-3	JBTN-B109MRF0	M	Select button [R-1501]	1	AC
3- 2-3	JBTN-B107MRF0	M	Select button [R-1505]	1	AC
3- 2-3	JBTN-B109MRF0	M	Select button [R-1506]	1	AC
3- 2-4	MSPRTA050WRE0	M	Button spring	1	AA
3- 3	LHLD-B009MRF0	M	LCD holder	1	AF
3- 4	PSHEPB023MRE0	M	LED sheet	1	AR
3- 5	XEPSD30P10XS0	M	Screw; 3mm x 10mm	5	AB

OVEN PARTS

4- 1	LSTPPB038MRF0	M	Door stopper	1	AB
4- 2	FROLPB025MRK0	M	Turntable support assembly	1	AN
4- 3	NTNT-A095WRE0	M	Turntable tray	1	AN
4- 4	LBNDKB009MRP0	M	Capacitor holder	1	AB
4- 5	PDUC-B111MRF0	M	Magnetron duct	1	AF
4- 6	MLEVBP016MRF0	M	Open lever	1	AD
4- 7	*****	M	Oven cavity (Not replaceable part)	1	--
4- 8	PPACGB014MRF0	M	Turntable motor packing	1	AA
4- 9	PHOK-B018MRF0	M	Latch hook	1	AF
4-10	FANGTB005MRY0	M	Unit mounting plate assembly	1	AS
4-11	NFANPB006MRE0	M	Fan blade	1	AC
4-12	LBSHC0037WRE0	M	Cord bushing	1	AB
4-13	MLEVFB007MRP0	M	Mounting lever	2	AC
4-14	PDUC-B112MRP0	M	Hood intake duct R	1	AG
4-15	PCOVBP085MRP0	M	Waveguide cover	1	AH
4-16	MSPRTA046WRE0	M	Latch spring	2	AB
4-17	LANGTB055MRP0	M	Chassis support	2	AD
4-18	PDUC-B115MRF0	M	Hood duct R	1	AQ
4-19	PDUC-B114MRF0	M	Hood duct L	1	AQ
4-20	PDUC-B113MRP0	M	Fan duct	1	AH
4-21	PDUC-B117MRF0	M	Orifice	1	AC
4-22	PCUSGB043MRP0	M	Transformer cushion	1	AC

DOOR PARTS

5	CDORFB279MRK0	M	Door assembly [R-1500]	1	BD
5	CDORFB280MRK0	M	Door assembly [R-1501]	1	BD
5	CDORFB283MRK0	M	Door assembly [R-1505]	1	BD
5	CDORFB284MRK0	M	Door assembly [R-1506]	1	BD
5- 1	FDORFB070MRT0	M	Door panel assembly	1	AW
5- 2	FCOV-B186MRK0	M	Door frame assembly [R-1500]	1	AY
5- 2	FCOV-B187MRK0	M	Door frame assembly [R-1501]	1	AY
5- 2	FCOV-B191MRK0	M	Door frame assembly [R-1505]	1	AY
5- 2	FCOV-B192MRK0	M	Door frame assembly [R-1506]	1	AY
5-2-1	LSTPPB021MRF0	M	Latch head	1	AD
5-2-2	MSPRTA046WRE0	M	Latch spring	1	AB
5-2-3	LSTPPB037MRF0	M	Glass stopper	2	AC
5- 3	GCOVHB044MRF0	M	Choke cover	1	AG
5- 4	PSHEPB021MRE0	M	Sealer film	1	AE
5- 5	XCPSD40P08000	M	Screw : 4mm x 8mm	2	AA

MISCELLANEOUS

6- 1	CFZK-B460MRK0	M	Installation material assembly	1	AH
6-1-1	LBSHC0040MRE0	M	Grommet	1	AC
6-1-2	LX-BZ0195WRE0	M	Toggle screw	4	AC
6-1-3	LX-MZB001MRE0	M	Cord holder	1	AB
6-1-4	XBRSD50P60000	M	Screw : 5mm x 60mm	2	AA
6-1-5	XOTSD40P12000	M	Screw : 4mm x 12mm	3	AA
6-1-6	XTSSD50P35000	M	Screw : 5mm x 35mm	6	AA

REF. NO.	PART NO.	§	DESCRIPTION	Q'TY	CODE
6-1-7	XWHSD50-16300	M	Washer	2	AA
6-1-8	LANG-B002MRP0	M	Scale plate	2	AD
6- 2	TINSEB283MRR0	M	Installation instruction	1	AB
6- 3	TINSEB282MRK0	M	Operation manual	1	AD
6- 4	TINSKB075MRR0	M	Top template	1	AB
6- 5	TINSKB076MRR0	M	Wall template	1	AB
* 6- 6	QW-QZB025MRE0	M	High voltage wire A	1	AT
6- 7	FW-VZB187MRE0	M	Main harness	1	AT
6- 8	TCAUAB041MRR0	M	DHHS service caution label	2	AA
6- 9	TCAUAB037MRR0	M	Monitor caution label	1	AA
6-10	TCAUAB005MRR0	M	Revised DHHS/GRD C/label	1	AB
6-11	FW-VZB188MRE0	M	Low voltage harness	1	AT
6-12	PFIL-B006MRE0	M	Charcoal filter	1	AE
6-13	PFIL-B002MRE0	M	Grease filter	2	AF
6-14	FFTA-B003MRK0	M	Exhaust damper assembly	1	AH

SCREWS,NUTS AND WASHERS

7- 1	LX-CZB004MRE0	M	Special screw	3	AA
7- 2	XOTSE40P12000	M	Screw : 4mm x 12mm	4	AA
7- 3	XOTSD40P12000	M	Screw : 4mm x 12mm	18	AA
7- 4	XBPSD40P08000	M	Screw : 4mm x 8mm	2	AA
7- 5	LX-CZA038WRE0	M	Special screw	6	AA
7- 6	LX-CZ0052WRE0	M	Special screw	2	AA
7- 7	LX-BZ0081YBE0	M	Screw : 4mm x 8mm	4	AA
7- 8	XCP3SD30P08000	M	Screw : 4mm x 8mm	2	AA
7- 9	LX-BZA041WRE0	M	Special screw	1	AA
7-10	XCBSD30P08000	M	Screw : 3mm x 8mm	1	AA

HOW TO ORDER REPLACEMENT PARTS

To have your order filled promptly and correctly, please furnish the following information.

1. MODEL NUMBER 2. REF. NO. 3. PART NO. 4. DESCRIPTION

Order Parts from the authorized SHARP parts Distributor for your area.

Defective parts requiring return should be returned as indicated in the Service Policy.

PACKING AND ACCESSORIES

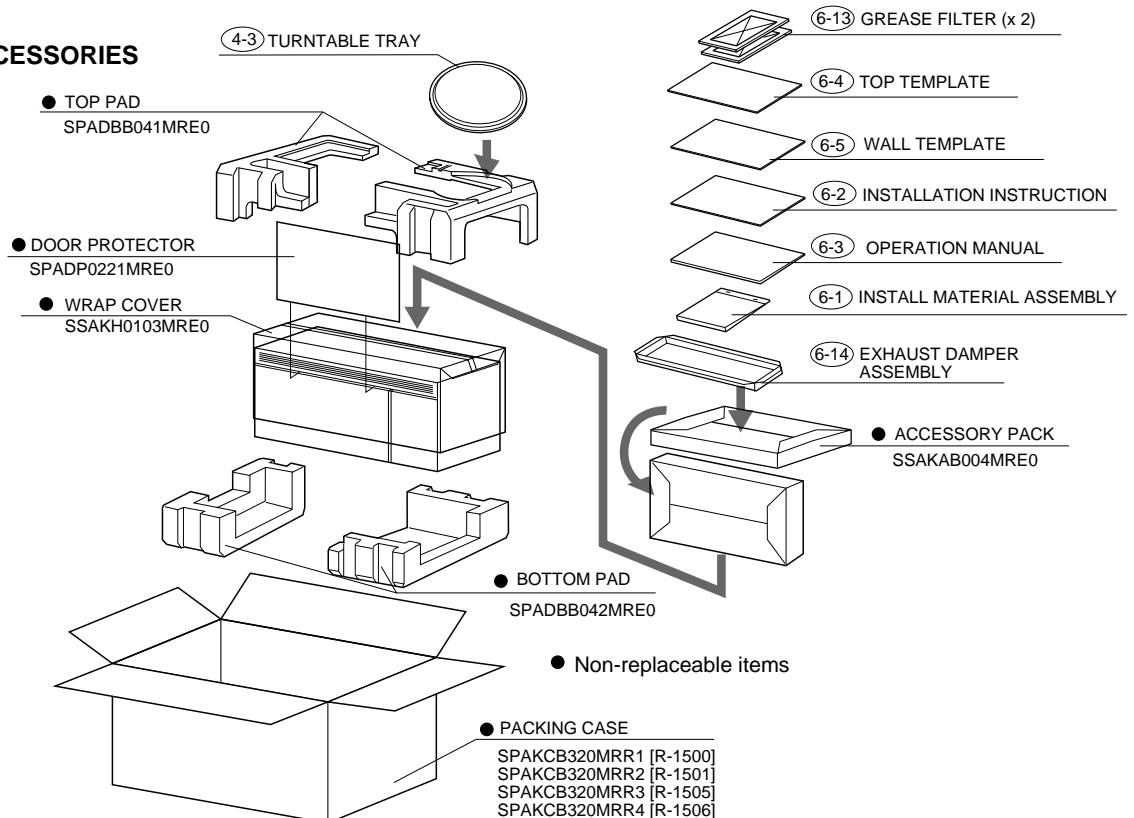

OVEN AND CABINET PARTS

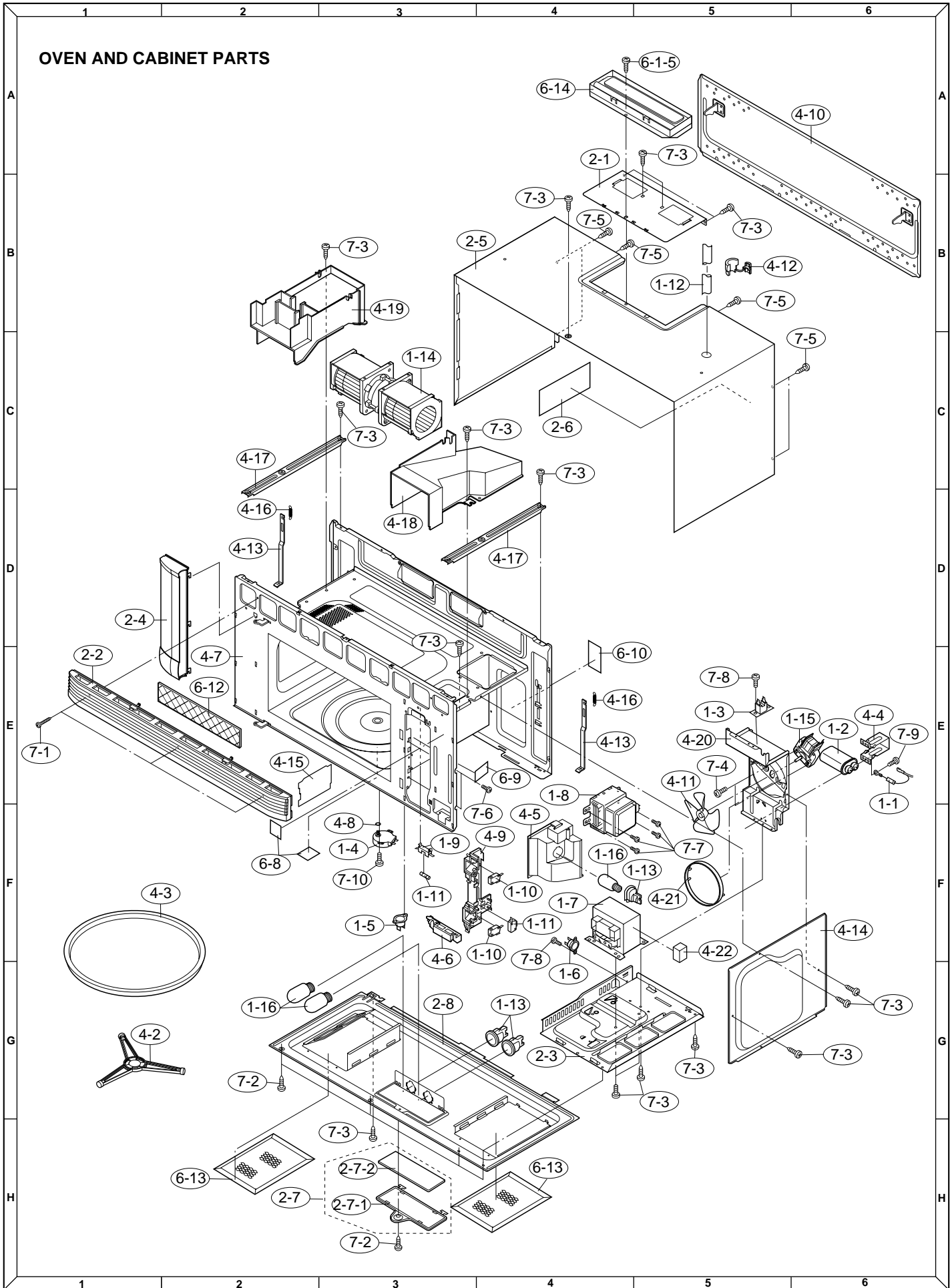

SHARP

COPYRIGHT © 2001 BY SHARP CORPORATION

ALL RIGHTS RESERVED.

No part of this publication may be reproduced, stored in retrieval systems, or transmitted in any form or by any means, electronic, mechanical, photocopying, recording, or otherwise, without prior written permission of the publisher.