

Panasonic®

Operating Instructions

Convection Microwave Oven

Household Use Only

Model No. NN-CF770M

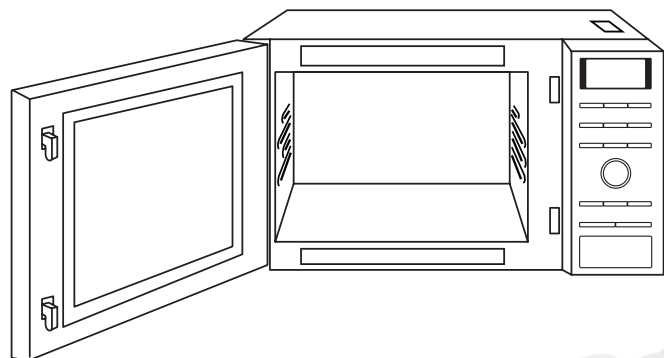

INVERTER

1000 W



**READ ALL INSTRUCTIONS CAREFULLY BEFORE USING THE OVEN
AND KEEP THIS MANUAL FOR FUTURE USE.**

Inverser le manuel pour lire les instructions en français.

Panasonic Canada Inc.
5770 Ambler Drive
Mississauga, Ontario
L4W 2T3
Tel: (905) 624-5010
www.panasonic.ca

F00039M80CP
IP0910-0
Printed in China

© Panasonic Home Appliances Microwave Oven (Shanghai) Co., Ltd. 2010.

Table of Contents

Safety Information

Microwave Oven Safety	3
Important Safety Instructions	4-5
Installation and Grounding Instructions	6-7
Safety Precautions	8-9

Operation

Control Panel.....	14
Display Window.....	15
Dial Feature	15
Starting to Use Your Oven	16
Function Feature	16
Setting the Clock	17
Child Safety Lock	17
DEMO MODE.....	17
Menu Action ON/OFF Feature	17
Selecting Power & Cook Time	18
Quick Min Feature	18
Popcorn Feature.....	19
More/Less Feature	19
Inverter Turbo Defrost Feature.....	20
Defrosting Tips & Techniques.....	20-21
Grill Feature.....	22
Combination Feature.....	23
Convection Feature	24
Auto Reheat Feature	25
Auto Cook Feature	25
Auto Cook Chart.....	26-27
Timer Feature (Kitchen Timer/Stand Time/Delay Start)	28
Microwave Shortcuts	29-30
Food Characteristics	31
Cooking Techniques	31-32
Quick Guide to Operation.....	36-37

Maintenance

Care and Cleaning of Your Microwave Oven	12
Before Requesting Service	33-34
Warranty	35

General Information

Cooking Mode & Cookware Guide.....	10-11
Oven Components Diagram.....	13
Cooking Modes & Accessories.....	15
Specifications	38
User's Record.....	38

Microwave Oven Safety

Your safety and the safety of others are very important.

We have provided important safety messages in this manual and on your appliance. Always read and obey all safety messages.



This is the safety alert symbol. It is used to alert you to potential hazards that can kill or hurt you and others.

All safety messages will follow the safety alert symbol and either the word "DANGER", "WARNING" or "CAUTION". These words mean:

DANGER

You can be killed or seriously injured if you don't immediately follow instructions.

WARNING

You can be killed or seriously injured if you don't follow instructions.

CAUTION

You can be exposed to a potentially hazardous situation which, if not avoided, may result in minor or moderate injury.

All safety messages will tell you what the potential hazard is, tell you how to reduce the chance of injury, and tell you what can happen if the instructions are not followed.



PRECAUTIONS TO AVOID POSSIBLE EXPOSURE TO EXCESSIVE MICROWAVE ENERGY

- (a) Do not attempt to operate this oven with the door open since open-door operation can result in harmful exposure to microwave energy. It is important not to defeat or tamper with the safety interlocks.
- (b) Do not place any object between the oven front face and the door or allow soil or cleaner residue to accumulate on sealing surfaces.
- (c) Do not operate the oven if it is damaged. It is particularly important that the oven door close properly and that there is no damage to the:
 - (1) door (bent),
 - (2) hinges and latches (broken or loosened),
 - (3) door seals and sealing surfaces.
- (d) The oven should not be adjusted or repaired by anyone except properly qualified service personnel.

Thank you for purchasing a Panasonic Microwave Oven.

Your microwave oven is a cooking appliance and you should use as much care as you use with a stove or any other cooking appliance. When using this electric appliance, basic safety precautions should be followed, including the following:



IMPORTANT SAFETY INSTRUCTIONS



WARNING

— To reduce the risk of burns, electric shock, fire, injury to persons, or exposure to excessive microwave energy:

1. Read all instructions before using this appliance.
2. Read and follow the specific "PRECAUTIONS TO AVOID POSSIBLE EXPOSURE TO EXCESSIVE MICROWAVE ENERGY," found on page 3.
3. This appliance must be grounded. Connect only to a properly grounded outlet. See "GROUNDING INSTRUCTIONS" found on page 6.
4. As with any cooking appliance, **DO NOT** leave oven unattended while in use.
5. Install or locate this appliance only in accordance with the installation instructions found on page 6.
6. **DO NOT** cover or block any openings on this appliance.
7. **DO NOT** store this appliance outdoors. **DO NOT** use this product near water — for example, near a kitchen sink, in a wet basement, or near a swimming pool or similar locations.
8. Use this appliance only for its intended use as described in this manual. **DO NOT** use corrosive chemicals, vapors or non-food products in this appliance. This type of oven is specifically designed to heat, or cook food. It is not designed for industrial or laboratory use. The use of corrosive chemicals in heating or cleaning will damage the appliance and may result in radiation leaks.
9. When cleaning surfaces of the door and oven that come together upon closing the door, use only mild, non-abrasive soaps or detergents applied with a sponge or soft cloth.
10. **DO NOT** allow children to use this appliance, unless closely supervised by an adult. **DO NOT** assume that because a child has mastered one cooking skill he/she can cook everything.
11. **DO NOT** operate this appliance if it has a damaged cord or plug, if it is not working properly, or if it has been damaged or dropped.
12. **DO NOT** immerse cord or plug in water.
13. Keep cord away from heated surfaces.
14. **DO NOT** let cord hang over edge of a table or counter.
15. This appliance should be serviced only by qualified service personnel. Contact the nearest authorized service center for examination, repair or adjustment.
16. Some products such as whole eggs with or without shell, narrow neck bottles and sealed containers — for example, closed glass jars — may explode and should not be heated in this oven.
17. To reduce the risk of fire in the oven cavity:
 - (a) Do not overcook food. Carefully attend appliance when paper, plastic, or other combustible materials are placed inside the oven to facilitate cooking.
 - (b) Remove wire twist-ties from paper or plastic bags before placing bag in oven.
 - (c) **If material inside the oven ignites, keep oven door closed, turn oven off, and disconnect the power cord, or shut off power at the fuse or circuit breaker panel.**
 - (d) **DO NOT** use the cavity for storage purposes. **DO NOT leave paper products, cooking utensils or food in the cavity when not in use.**
18. **Superheated Liquids**

Liquids, such as water, coffee or tea are able to be overheated beyond the boiling point without showing evidence (or signs) of boiling. Visible bubbling is not always present when the container is removed from the microwave oven. THIS COULD RESULT IN VERY HOT LIQUIDS SUDDENLY BOILING OVER WHEN THE CONTAINER IS DISTURBED OR A UTENSIL IS INSERTED INTO THE LIQUID.

To reduce the risk of injury to persons:

 - (a) **STIR THE LIQUID BOTH BEFORE AND HALFWAY THROUGH HEATING IT.**
 - (b) **DO NOT heat water and oil, or fats together. The film of oil will trap steam, and may cause a violent eruption.**
 - (c) Do not use straight-sided containers with narrow necks.
 - (d) After heating, allow the container to stand in the microwave oven for a short time before removing the container.
19. **DO NOT** cook directly on the Flat Table. It can crack, cause injury or damage to the oven.



IMPORTANT SAFETY INSTRUCTIONS

(continued)

WARNING

TO AVOID THE RISK OF SHOCK:

DO NOT remove outer panel from oven. Repairs must be done only by a qualified service person.

TO REDUCE THE RISK OF EXPOSURE TO MICROWAVE ENERGY:

DO NOT tamper with, or make any adjustments or repairs to Door, Control Panel Frame, Safety Interlock Switches, or any other part of oven. Microwave leakage may result.

TO AVOID THE RISK OF FIRE:

1. **DO NOT** operate the oven empty. The microwave energy will reflect continuously throughout the oven causing overheating and damage, if food or water is not present to absorb energy.
2. **DO NOT** store flammable materials next to, on top of, or in the oven.
3. **DO NOT** dry clothes, newspapers or other materials in the oven, or use newspaper or paper bags for cooking.
4. **DO NOT** hit or strike Control Panel. Damage to controls may occur.
5. **DO NOT** use recycled paper products unless the paper product is labeled as safe for microwave oven use. Recycled paper products may contain impurities which may cause sparking.

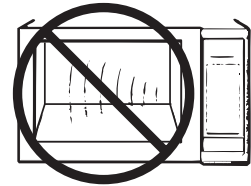
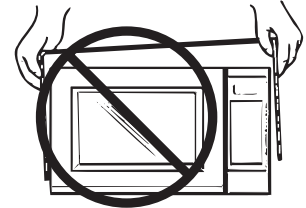

TO AVOID THE RISK OF SCALDING:

POT HOLDERS should always be used when removing items from the oven. Heat is transferred from the HOT food to the cooking container and from the container to the Flat Table. The Flat Table can also be very HOT after removing the cooking container from the oven.

WARNING

1. The door seals and door seal areas should be cleaned with a damp cloth. The appliance should be inspected for damage to the door seals and door seal areas and if these areas are damaged the appliance should not be operated until it has been repaired by a service technician trained by the manufacturer.
2. Do not attempt to tamper with or make any adjustments or repairs to the door, control panel housing, safety interlock switches or any other part of the oven. Do not remove the outer panel from the oven which gives protection against exposure to microwave energy. Repairs should only be done by a qualified service technician.
3. Do not operate this appliance if it has a damaged CORD OR PLUG, if it is not working properly, or if it has been damaged or dropped. It is dangerous for anyone other than a service technician trained by the manufacturer to perform repair service.
4. If the supply cord of this appliance is damaged, it must be replaced with the special cord available from the manufacturer.
5. This appliance is not intended for use by persons (including children) with reduced physical, sensory or mental capabilities, or lack of experience and knowledge unless they have been given supervision or instruction concerning use of the appliance by a person responsible for their safety. Young children should be supervised to ensure that they do not play with the appliance.
6. Only allow children to use the oven without supervision when adequate instructions have been given so that the child is able to use the oven in a safe way and understands the hazards of improper use, including escaping steam. To prevent burns, ensure that children do not touch either the hot inner surfaces or the hot outer casing after operation of the oven.
7. Liquids and foods must not be heated in sealed containers since they are liable to explode.
8. Take CAUTION when sliding out the oven tray from the sliding rail, do not let the oven tray rest half way on the sliding rail inside the oven. The sliding rail inside the oven is not designed with a stop-lock and the rail can not hold the oven tray.

Attention: Hot Surfaces



SAVE THESE INSTRUCTIONS

For proper use of your oven, read remaining safety cautions and operating instructions.



INSTALLATION AND GROUNDING INSTRUCTIONS

Examine Your Oven

Unpack oven, remove all packing material and examine the oven for any damage such as dents, broken door latches or cracks in the door. Notify dealer immediately if oven is damaged. **DO NOT** install if oven is damaged.

Placement of Oven

1. The oven must be placed on a flat, stable surface, which is 36" (91.6 cm) height from the ground. Place the front surface of the door three inches or more from the counter top edge to avoid accidental tipping of the microwave oven during normal use. For proper operation, the oven must have sufficient air flow. **Allow 6" (15 cm) of space on the top of the oven, 4" (10 cm) at the back, 2" (5 cm) on the left and the other side being open. If one side of the oven is placed flush against wall, the other side or the top must not be blocked. Do not remove the bottom feet from the oven.**
 - (a) **DO NOT** block air vents. If they are blocked during operation, the oven may overheat and be damaged. Also allow sufficient space on back and both sides of the oven.
 - (b) **DO NOT** place oven near a hot, damp surface such as a gas or electric range, or dishwasher.
 - (c) **DO NOT** operate oven when room humidity is excessive.
2. This oven is manufactured for household use only. It is not approved or tested for mobile vehicle, marine, or commercial use.

Installation

1. **DO NOT** block air vents. If they are blocked during operation, the oven may overheat. If the oven overheats, a thermal safety device will turn the oven off. The oven will remain inoperable until it has cooled.
2. If the oven is designed for installation into a wall cabinet, use the proper trim kit available from a local Panasonic dealer. Follow all instructions packed with the kit.



WARNING

— IMPROPER USE OF THE GROUNDING PLUG

CAN RESULT IN A RISK OF ELECTRIC SHOCK.

Consult a qualified electrician or service person if the grounding instructions are not completely understood, or if doubt exists as to whether the appliance is properly grounded. If it is necessary to use an extension cord, use only a three wire extension cord that has a three-prong polarized grounding plug, and a three-slot receptacle that will accept the plug of the appliance. The marked rating of the extension cord should be equal to or greater than the electrical rating of the appliance.

GROUNDING INSTRUCTIONS

THIS APPLIANCE MUST BE GROUNDED. In the event of an electrical short circuit, grounding reduces the risk of electric shock by providing an escape wire for the electric current. This appliance is equipped with a cord having a grounding wire with a grounding plug. The plug must be plugged into an outlet that is properly installed and grounded.

- **Plug into properly installed and grounded 3-prong outlet.**
- **DO NOT** remove ground prong.
- **DO NOT** use an adapter.



INSTALLATION AND GROUNDING INSTRUCTIONS

(continued)

Power Supply

1. A short power-supply cord is provided to reduce the risks resulting from becoming entangled in or tripping over a longer cord.
2. Longer cord sets or extension cords may be used if care is exercised in their use. **DO NOT** let cord hang over edge of a table or counter.
3. If a long cord or extension cord is used,
 - The marked electrical rating of the cord set or extension cord should be at least as great as the electrical rating of the appliance.
 - The extension cord must be a grounding-type 3-wire cord.
 - The longer cord should be arranged so that it will not drape over the counter top or tabletop where it can be pulled on by children or tripped over accidentally.

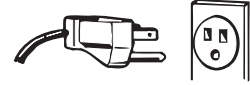

Wiring Requirements

1. The oven must be operated on a SEPARATE CIRCUIT. No other appliance should share the circuit with the microwave oven. If it does, the branch circuit fuse may blow or the circuit breaker may trip.
2. The oven must be plugged into a 15 AMP or 20 AMP, 120 VOLT, 60 Hz GROUNDED OUTLET. Where a standard two-prong outlet is encountered, it is the personal responsibility and obligation of the consumer to have it replaced with a properly grounded three-prong outlet.
3. The VOLTAGE used must be the same as specified on this microwave oven (120 V, 60 Hz). Using a higher voltage is dangerous and may result in a fire or oven damage. Using a lower voltage will cause slow cooking. Panasonic is NOT responsible for any damages resulting from the use of the oven with any voltage other than specified.

TV / Radio Interference

1. Operation of the microwave oven may cause interference to your radio, TV or similar equipment.
2. When there is interference, it may be reduced or eliminated by taking the following measures:
 - (a) Place the radio, TV, etc. away from the microwave oven as far as possible.
 - (b) Use a properly installed antenna to obtain stronger signal reception.
 - (c) Clean door and sealing surfaces of the oven. (See Care and Cleaning of Your Microwave Oven)

Fan Motor Operation

After using the oven repeatedly or for long time, the fan may operate to cool the electric components. This is perfectly normal, and you can take out the food from the oven while the fan operates.

It is recommended to keep the oven plugged in until the Fan Motor completely stops operating.

Oven Light

When it becomes necessary to replace the oven light, please consult Panasonic for the nearest authorized service centre for examination or repair. Contact information is provided in the Customer Services Directory page 35.



SAFETY PRECAUTIONS

Follow These Safety Precautions When Cooking in Your Oven.

IMPORTANT

Proper cooking depends upon the power, the time setting and quantity of food. If you use a smaller portion than recommended but cook at the time for the recommended portion, fire could result.

1) HOME CANNING / STERILIZING / DRYING FOODS / SMALL QUANTITIES OF FOODS

- **DO NOT** use your oven for home canning. Your oven cannot maintain the food at the proper canning temperature. The food may be contaminated and then spoil.
- **DO NOT** use the microwave oven to sterilize objects (baby bottles, etc.). It is difficult to keep the oven at the high temperature needed for sterilization.
- **DO NOT** dry meats, herbs, fruits or vegetables in your oven. Small quantities of food or foods with low moisture content can dry out, scorch or catch on fire if overheated.

2) POPCORN

Popcorn may be popped in a microwave oven corn popper. Microwave popcorn which pops in its own package is also available. Follow popcorn manufacturers' directions and use a brand suitable for the cooking power of your microwave oven.

CAUTION: When using pre-packaged microwave popcorn, you can follow recommended package instructions or use the popcorn button (refer to page 19). Otherwise, the popcorn may not pop adequately or may ignite and cause a fire. Never leave oven unattended when popping popcorn. Allow the popcorn bag to cool before opening; always open the bag facing away from your face and body to prevent steam burns.

3) DEEP FAT FRYING

- **DO NOT** deep fat fry in your microwave oven. Cooking oils may burst into flames and may cause damage to the oven and perhaps result in burns. Microwave utensils may not withstand the temperature of the hot oil, and can shatter or melt.

4) FOODS WITH NONPOROUS SKINS

- **DO NOT COOK/REHEAT WHOLE EGGS, WITH OR WITHOUT THE SHELL.** Steam buildup in whole eggs may cause them to explode, and possibly damage the oven or cause injury. Reheating SLICED hard-boiled eggs and cooking SCRAMBLED eggs is safe.
- **Potatoes, apples, whole squash and sausages** are examples of foods with nonporous skins. These types of foods must be pierced before microwave cooking to prevent them from exploding.
CAUTION: Cooking dry or old potatoes can cause fire.

5) FLAT TABLE / COOKING CONTAINERS / FOIL

- Cooking containers get hot during microwaving. Heat is transferred from the HOT food to the container and the Flat Table. Use pot holders when removing containers from the oven or when removing lids or plastic wrap covers from cooking containers, to avoid burns.
- The Flat Table will get hot during cooking. It should be allowed to cool before paper products, such as paper plates or microwave popcorn bags, are placed in the oven for microwave cooking.
- When using foil in the oven, allow at least 2.5 cm (1-inch) of space between foil and interior oven walls or door.
- Dishes with metallic trim should **not** be used, as arcing may occur.

6) PAPER TOWELS / CLOTHS

- **DO NOT** use paper towels or cloths which contain a synthetic fiber woven into them. The synthetic fiber may cause the towel to ignite. Use paper towels under supervision.

7) BROWNING DISHES / OVEN COOKING BAGS

- Browning dishes or grills are designed for microwave cooking only. Always follow instructions provided by the manufacturer. **DO NOT** preheat browning dish for longer than 6 minutes.
- If an oven cooking bag is used for microwave cooking, prepare according to package directions. **DO NOT** use a wire twist-tie to close bag; instead use plastic ties, cotton string or a strip cut from the open end of the bag.



SAFETY PRECAUTIONS

(continued)

8) THERMOMETERS

- **DO NOT** use a conventional meat thermometer in your oven. Arcing may occur. Microwave safe thermometers are available for both meat and candy.

9) BABY FORMULA / BABY FOOD

- **DO NOT** heat baby formula or baby food in the microwave oven. The glass jar or surface of the food may appear warm while the interior can be so hot as to burn the infant's mouth and esophagus.

10) REHEATING PASTRY PRODUCTS

- When reheating pastry products, check temperatures of any fillings before eating. Some foods have fillings which heat faster and can be extremely hot, while the surface remains warm to the touch (e.g. jelly donuts).

11) GENERAL OVEN USAGE GUIDELINES

- **DO NOT** use the oven for any purpose other than the preparation of food. This oven is specifically designed to heat or cook food. **DO NOT** use this oven to heat chemicals or other non-food products.
- Before use, check that utensils/containers are suitable for use in microwave ovens.
- **DO NOT** attempt to use this microwave oven to dry newspaper, clothing or any other materials. They may catch fire.
- When the oven is not being used, **DO NOT** store any objects other than oven accessories inside the oven in case it is accidentally turned on.
- The appliance shall not be operated by Microwave or Combination WITHOUT FOOD IN THE OVEN. Operation in this manner may damage the appliance.
- If smoke or a fire occurs in the oven, press the **Stop/Reset** button and leave the door closed in order to extinguish the flames. Disconnect the power cord, or shut off power at the fuse.
- Extreme caution must be used when moving hot liquids.
- When handling cooking containers take care not to let the contents spill.
- Avoid hot steam, serious burns and scalds could result.
- Do not use a steam cleaner to clean this appliance. The steam from the cleaning appliance could penetrate live components and permanently damage the oven or cause injury.
- The use of accessories not recommended by Panasonic may cause injury.

12) HEATER OPERATION

- Exterior oven surfaces, including air vents on the cabinet and the oven door will get hot during Convection, Combination or Grill functions. To prevent burns, take care when opening or closing the door and when inserting or removing food and accessories.
- The oven has heaters situated in the top and rear of the oven. During and after using either the Convection, Combination or Grill functions, all inside surfaces of the oven will be very hot. To prevent burns, care should be taken to avoid touching the inside surfaces of the oven.
- **TO AVOID THE RISK OF SCALDING**, please use caution when touching accessible parts when oven is operated in Convection, Grill or Combination mode, because the accessible parts may become extremely hot.

13) BEFORE USING YOUR OVEN

- Before using the oven for the first time, wipe excessive oil off in the oven cavity and operate the oven without food and accessories on Convection at 450°F (230°C), for 10 minutes. This will allow the oil that is **used for rust protection to be burned off. This is the only time the oven is used empty.** (with the exception of preheating on Convection)

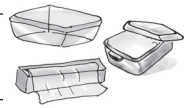

Cooking Mode & Cookware Guide

Item		Microwave	Grill	Convection	Combination	Comments
Heating Mode		Microwave	Heating Element	Heating Element	Microwave & Heating Element	Please see page 15.
Aluminum Foil		Yes for Shielding only	Yes	Yes	Yes for Shielding only	Small strips of foil can be molded around thin parts of meat or poultry to prevent overcooking. Arcing can occur if foil is too close to oven wall or door and damage to your oven will result.
Browning Dish		Yes	No	No	No	Browning dishes are designed for microwave cooking only. Check browning dish information for instructions and heating chart. Do not preheat for more than 6 minutes.
Dinnerware	Labeled "Oven/Microwave Safe"	Yes	Yes	Yes	Yes	Check manufacturers' use and care directions for use in oven/microwave heating. Some dinnerware may state on the back of the dish, "Oven/Microwave Safe".
	Labeled "Microwave Safe"	Yes	No	No	No	
	Unlabeled	?	No	No	No	Use CONTAINER TEST on next page.
Disposable polyester Paperboard Dishes		Yes	No	No	No	Some frozen foods are packaged in these dishes. Can be purchased in grocery stores.
Fast Food Carton with Metal Handle		No	No	No	No	Metal handle may cause arcing and create a fire hazard.
Frozen Dinner Tray Metal		No	Yes	Yes	No	Metal can cause arcing and damage to your oven in the Microwave and Combination modes.
Frozen Dinner Tray Microwave safe		Yes	No	No	No	For one time use only. Do not reuse.
Glass Jars		No	No	No	No	Most glass jars are not heat resistant. Do not use for cooking or reheating.
Heat Resistant Oven Glassware & Ceramics		Yes	Yes	Yes	Yes	Ideal for microwave cooking and browning. (See CONTAINER TEST on next page)
Metal Convection Bakeware		No	Yes	Yes	No	Metal can cause arcing and damage to your oven in the Microwave and Combination modes.
Metal Twist-Ties		No	Yes	Yes	No	Metal can cause arcing and damage to your oven in the Microwave and Combination modes.
Oven Cooking Bag		Yes	Yes	Yes	Yes	Follow manufacturers' directions. Close bag with the nylon tie provided, a strip cut from the end of the bag, or a piece of cotton string. Do not close with metal twist-tie for the Microwave or Combination mode. Make six ½-inch (1 cm) slits near the closure.
Paper bags		No	No	No	No	May cause a fire in the oven.

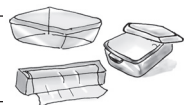

Cooking Mode & Cookware Guide (continued)

Item	Microwave	Grill	Convection	Combination	Comments
Paper Plates & Cups	Yes, with supervision	No	No	No	Use to warm cooked foods, and to cook foods that require short cooking time such as hot dogs in the Microwave mode.
Paper Towels & Napkins	Yes, with supervision	No	No	No	Use to warm rolls and sandwiches, only if labeled safe for microwave use.
Recycled Paper Towels & Napkins	No	No	No	No	Recycled paper products may contain impurities which may cause sparks or create a fire hazard.
Parchment Paper	Yes	Yes	Yes	Yes	Use as a cover to prevent spattering. Safe for use in the Microwave, Convection Bake and Combination modes.
Plastic, Microwave Safe	Yes, use caution	No	No	No	Should be labeled, "Suitable for Microwave Heating." Check manufacturers' directions for recommended uses. Some microwave safe plastic containers are not suitable for cooking foods with high fat or sugar content. The heat from hot food may cause the plastic to warp.
Plastic, Melamine	No	No	No	No	This material absorbs microwave energy. Dishes get HOT!
Plastic Foam Cups	Yes, short term only	No	No	No	Plastic foam will melt if foods reach a high temperature. Use caution to reheat foods to a low serving temperature only.
Silicon Rubber Container	Yes	Yes	Yes	Yes	Check Manufacturer's directions for recommended uses.
Plastic Wrap	Yes	No	No	No	Use to cover food during cooking to retain moisture and prevent spattering. Should be labeled "Suitable for Microwave Heating". Check package directions.
Straw, Wicker, Wood	Yes, short term only	No	No	No	Use only for short term reheating and to bring food to a low serving temperature. Wood may dry out & split or crack when used.
Thermometers, Microwave safe	Yes	No	No	No	Use only microwave safe meat and candy thermometers.
Thermometers, Conventional	No	Yes	Yes	No	Not suitable for use in microwave oven, will cause sparks and get hot.
Wax paper	Yes	No	No	No	Use as a cover to prevent spattering and to retain moisture in the Microwave mode only.

CONTAINER TEST

TO TEST A CONTAINER FOR SAFE MICROWAVE OVEN USE: Fill a microwave safe cup with cool water and place it in the microwave oven alongside the empty container to be tested; **heat one (1) minute at HIGH.** If the container is microwave oven safe (transparent to microwave energy), the empty container should remain comfortably cool and the water should be hot. If the container is hot, it has absorbed some microwave energy and should NOT be used. This test cannot be used for plastic containers.



Care and Cleaning of Your Microwave Oven

BEFORE CLEANING:

Unplug oven at wall outlet. If outlet is inaccessible, leave oven door open while cleaning.

AFTER CLEANING:

Be sure the microwave oven is clean and dry, then press **Stop/Reset** button to clear the Display.

Menu Label/Warning Label:

Do not remove, wipe with a damp cloth.

Outside oven surfaces:

Clean with a damp cloth.

To prevent damage to the operating parts inside the oven, water should not be allowed to seep into ventilation openings.

Inside of the oven:

Wipe with a damp cloth after using. Mild detergent may be used if needed. Do not use harsh detergents or abrasives.

Control Panel:

- Covered with a removable protective film to prevent scratches during shipping. Small bubbles may appear under this film. (*Hint - To remove film, apply masking or clear tape to an exposed corner and pull gently.*)
- If the Control Panel becomes wet, clean it with a soft, dry cloth. Do not use harsh detergents or abrasives.

Oven Door:

Wipe with a soft, dry cloth when steam accumulates inside or around the outside of the oven door. During cooking, especially under high humidity conditions, steam is given off from the food. (Some steam will condense on cooler surfaces, such as the oven door. This is normal.) Inside surface is covered with a heat and vapor barrier film. **Do not remove.**

Oven cavity floor:

Clean the bottom surface of the oven with mild detergent water or window cleaner, and dry.

After using, clean it with a mild detergent or dishwasher.

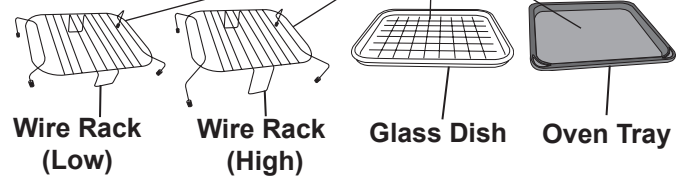

Notes:

1. When using the Convection, Grill or cooking in the Combination mode, some foods may inevitably splatter grease on to the oven walls. If the oven is not cleaned, occasionally it may start to "smoke" during use. These marks will be more difficult to clean later.
2. After Grill, Combination or Convection cooking the ceiling and walls of the oven should be cleaned with a soft cloth squeezed in soapy water. Particular care should be taken to keep the window area clean particularly after cooking by Grill, Combination or Convection. Stubborn spots inside the oven can be removed by using a small amount of microwave oven cleaner sprayed onto a soft damp cloth. Wipe onto problem spots, leave for recommended time and then wipe off. This method cannot be used to clean the oven door.
DO NOT SPRAY DIRECTLY INSIDE THE OVEN.
A steam cleaner is not to be used for cleaning.
3. Do not use harsh abrasive cleaners or sharp metal scrapers to clean the oven door glass since they can scratch the surface, which may result in shattering of the glass.

IT IS IMPORTANT TO KEEP THE OVEN CLEAN AND DRY. FOOD RESIDUE AND CONDENSATION MAY CAUSE RUSTING OR ARCING AND DAMAGE TO THE OVEN. AFTER USE, WIPE DRY ALL SURFACES-INCLUDING VENT OPENINGS, OVEN SEAMS.

Oven Components Diagram

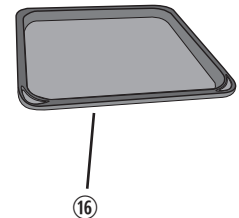
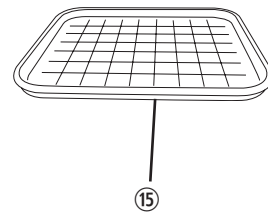
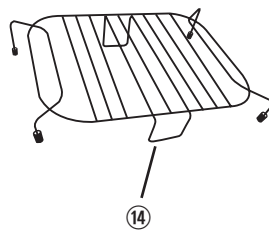
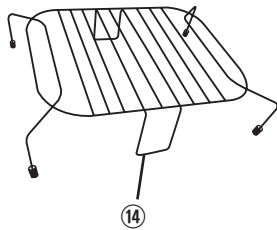
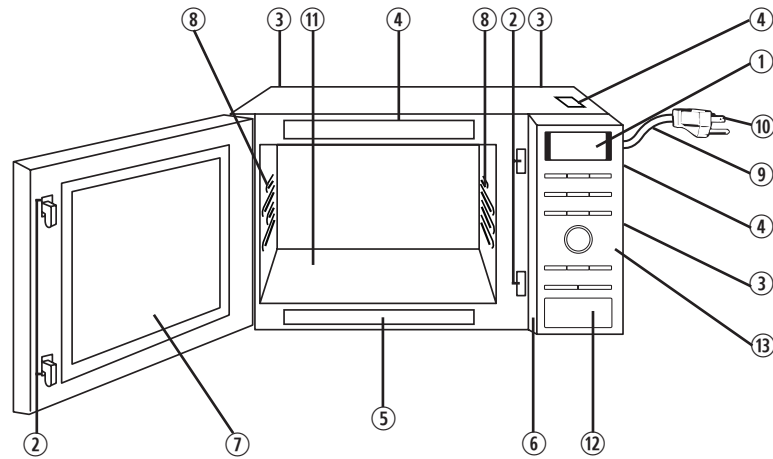

- ① **Display Window**
- ② **Door Safety Lock System**
- ③ **Oven Air Vent**
- ④ **Warning Label**
- ⑤ **Menu Label**
- ⑥ **Identification Plate**
- ⑦ **Oven Window**
- ⑧ **Rail (use only for Oven Tray)**

- ⑨ **Power Supply Cord**
- ⑩ **Power Supply Plug**
- ⑪ **Flat Table**

1. If the flat table is hot, allow cooling down before cleaning.
2. Do not cook directly on the flat table. Always put food in a container or on a rack.

- ⑫ **Door Release Button**

Push to open the door. Opening the door during cooking will stop the cooking process without cancelling the program. Cooking resumes as soon as the door is closed and **Start** button is pressed. It is quite safe to open the door at any time during a cooking program and there is no risk of Microwave exposure.

- ⑬ **Control Panel**

- ⑭ **Wire Rack (High, Low)**

- (a) Wire Rack is included with the oven in order to facilitate browning of small dishes.
- (b) Wire Rack should be cleaned regularly.
- (c) When using Wire Rack in the manual GRILL or COMBINATION cooking modes, be careful to choose heat-proof containers; containers made of plastic or paper may melt or burn when exposed to the heat radiating from the grill.
- (d) When using the COMBINATION mode, never place any aluminum or metal container directly on Wire Rack. Always insert a glass plate or dish between Wire Rack and the aluminum container. This will prevent sparking that may damage the oven.
- (e) Do not use Wire Rack when cooking in the MICROWAVE mode.
- (f) Don't use it together with oven tray.

- ⑮ **Glass Dish**

Never insert in the sets of rails.

- ⑯ **Oven Tray**

1. For convection, grill only.
2. After cooking, don't touch it by hand directly to avoid scalding.

Oven Light

Oven Light will turn on during cooking and also when door is opened.

Note:

The above illustration is for reference only.

Control Panel

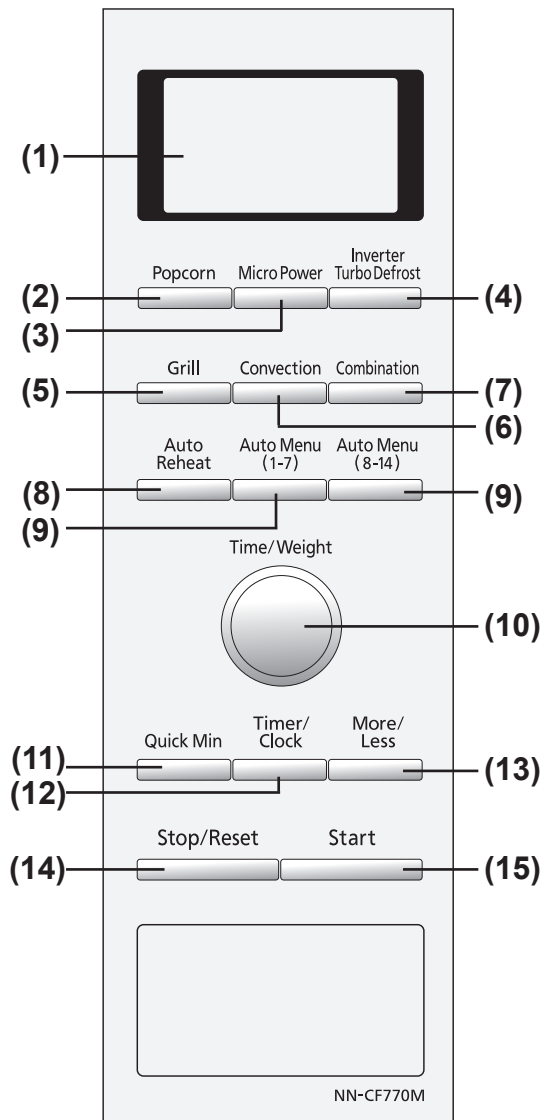

- (1) **Display Window** (see page 15)
- (2) **Popcorn Button** (see page 19)
- (3) **Micro Power Button** (see page 18)
- (4) **Inverter Turbo Defrost Button** (see page 20)
- (5) **Grill Button** (see page 22)
- (6) **Convection Button** (see page 24)
- (7) **Combination Button** (see page 23)
- (8) **Auto Reheat Button** (see page 25)
- (9) **Auto Cook Buttons** (see page 25)
- (10) **Time/Weight Dial** (see page 15)
Press and release dial to expand (pop-out). After setting desired program, push dial in to avoid accidental changing of the programmed time.
- (11) **Quick Min Button** (see page 18)
- (12) **Timer/Clock Button** (see page 17, 28)
- (13) **More/Less Button** (see page 19)
- (14) **Stop/Reset Button**
Before cooking: One tap clears all your instructions.
During cooking: One tap temporarily stops the cooking process. Another tap cancels all your instructions and colon or time of day appears in the Display Window.
- (15) **Start Button**
One tap allows oven to begin functioning. If door is opened or **Stop/Reset** button is pressed once during oven operation, **Start** button must be pressed again to restart oven.

Word Prompters

When a button is pressed correctly, a beep sound will be heard and the corresponding letter or word(s) appear and roll across the Display Window. If a button is pressed and no beep is heard, the unit did not or could not accept the instruction. As each button is pressed the corresponding word(s) roll across the Display Window. Words will automatically appear to prompt the user to perform the next step. It is not necessary to wait for the words to appear before pressing buttons for the next step. A two beep sound is heard between stages. At the end of any complete program, the oven will beep five times and "ENJOY YOUR MEAL" will appear in the Display Window.

Notes:

1. If an operation is set and **Start** button is not pressed, after 6 minutes, the oven will automatically cancel the operation. The display will revert back to clock or colon mode.
2. If no beep sound is heard, check "Beep ON/OFF" function feature (see page 16).

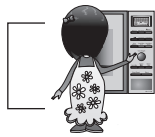

Display Window

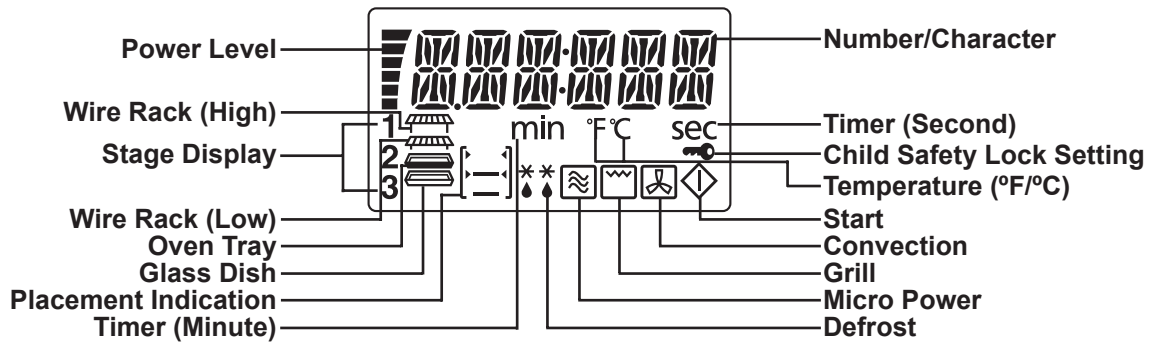

Dial Feature

Time/Weight

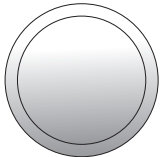

- Time Choice**
Rotate the dial clockwise to increase the cooking time and rotate the dial counter-clockwise to decrease the cooking time.
- Weight Choice**
Rotate the dial clockwise to increase the weight and rotate the dial counter-clockwise to decrease the weight setting.

Note:

The maximum programmable time using Time Dial is up to 1 hour and 30 minutes. For HIGH power, the maximum time is 30 minutes. For Combination and Convection power, the maximum time is 9 hours.

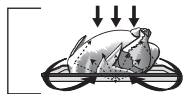

Cooking Modes & Accessories

The diagrams shown below are examples of the accessories. It may vary depending on recipe/dish used.

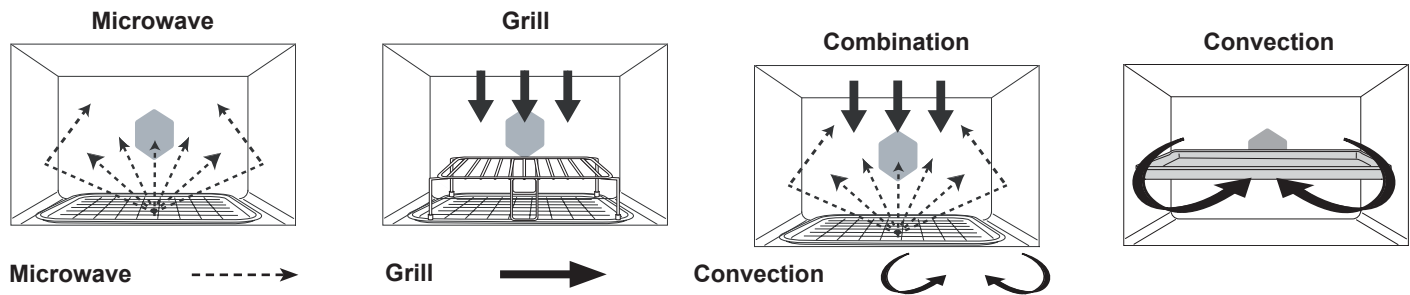

The following chart shows correct use of the accessories in the oven.

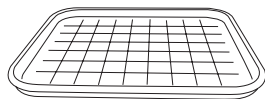
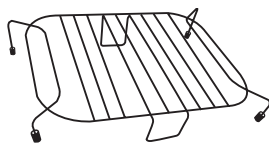
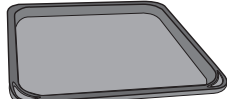
			
	Glass Dish	Wire Rack	Oven Tray
Micro Power	√	Do not use	Do not use
Grill	√	√	√
Combination	√	√*	Do not use
Convection	√	√	√

*: Metal containers can not be placed directly on the wire rack in combination mode.

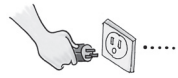

Starting to Use Your Oven

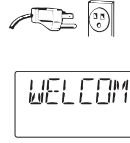







- Plug into a properly grounded electrical outlet.
- **"WELCOME TO PANASONIC REFER TO OPERATING INSTRUCTIONS BEFORE USE"** scrolls across display window.





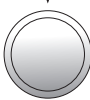



Function Feature

This unique function of your PANASONIC microwave oven allows you to establish the initial non-cooking features of your Oven. This microwave oven has three functions:

- **LB/KG CHOICE:** The oven has both imperial and metric weight measurements.
- **LANGUAGE CHOICE:** The oven has a choice of English, French or Spanish display.
- **BEEP CHOICE:** The oven has both Beep On and Beep Off mode.



 <ul style="list-style-type: none"> • Plug into a properly grounded electrical outlet. 		
LB/KG CHOICE	LANGUAGE CHOICE	BEEP CHOICE
<p>Start</p>  <ul style="list-style-type: none"> • Press Start button once. <p>The oven automatically defaults to the imperial measure system (LB).</p> <p>↓</p>  <ul style="list-style-type: none"> • Rotate the dial to choose metric weight measurements (KG). 	<p>Start</p>  <ul style="list-style-type: none"> • Press Start button twice. <p>The default display language is English.</p> <p>↓</p>  <p>More/ Less</p> <ul style="list-style-type: none"> • Press More/Less button once. • Press More/Less button twice. <p>The display language changes to French. The display language changes to Spanish.</p>	<p>Start</p>  <ul style="list-style-type: none"> • Press Start button 3 times. <p>The default mode is Beep On.</p> <p>↓</p>  <p>Timer/ Clock</p> <ul style="list-style-type: none"> • Press Timer/Clock button once. <p>The mode changes to Beep Off.</p>

Set LB/KG, LANGUAGE and BEEP by following the steps below:

<p>1.</p> 	<ul style="list-style-type: none"> • Plug into a properly grounded electrical outlet.
<p>2.</p> <p>Start</p> 	<ul style="list-style-type: none"> • Plug Start button once.
<p>3.</p> 	<ul style="list-style-type: none"> • Rotate the dial to choose metric weight measurements (KG).
<p>4.</p> <p>Start</p> 	<ul style="list-style-type: none"> • Plug Start button once to set Language.
<p>5.</p> <p>More/ Less</p> 	<ul style="list-style-type: none"> • Plug More/Less button once. • The display language changes to French. • Press More/Less button twice. • The display language changes to Spanish.
<p>6.</p> <p>Start</p> 	<ul style="list-style-type: none"> • Press Start button once to Beep Choice.
<p>7.</p> <p>Timer/ Clock</p> 	<ul style="list-style-type: none"> • Press Timer/Clock button once. • The mode changes to Beep Off.



Setting the Clock

1.  Timer/ Clock	<ul style="list-style-type: none"> • Press Timer/Clock button twice. ▶ Colon flashes.
2.  Time Dial Rotate	<ul style="list-style-type: none"> • Set time of day using Time dial. ▶ Time appears in the display window; colon continues flashing.
3.  Timer/ Clock	<ul style="list-style-type: none"> • Press Timer/Clock button once. ▶ Colon stops flashing; time of day is entered.



Notes:

1. To reset the clock, repeat step 1-3.
2. The clock will retain the time of day as long as the oven is plugged in and electricity is supplied.
3. Clock is a 12-hour display.
4. Oven will not operate while colon is flashing.



Child Safety Lock

This feature prevents the electronic operation of the oven until cancelled. It does not lock the door.

To Set: 	<ul style="list-style-type: none"> • Press Start button 3 times. "LOCK" appears in the display window. ▶ "LOCK" continues to be displayed until Child Safety Lock is cancelled. Any buttons may be pressed but the microwave will not start.
To Cancel: 	<ul style="list-style-type: none"> • Press Stop/Reset button 3 times. ▶ The display will return to colon or time of day when Child Safety Lock Time Dial has been cancelled.

Notes:



1. You can set Child Safety Lock feature when the display shows a colon or time of day.
2. To set/cancel Child Safety Lock, button must be pressed 3 times within a 10 second period.



DEMO MODE

When "DEMO MODE PRESS ANY KEY" appears in the display window, it means the oven is under demonstration mode, microwave does not emit. Demo mode is designed for retail store display. In this mode, the oven can be demonstrated with no cooking power in the oven.

To cancel:

1.  Micro Power	<ul style="list-style-type: none"> • Press Micro Power button once.
2.  Start	<ul style="list-style-type: none"> • Press Start button 4 times.
3.  Stop/Reset	<ul style="list-style-type: none"> • Press Stop/Reset button 4 times.

Note:

To set Demo Mode, repeat step 1-3.

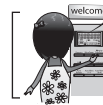

Menu Action ON/OFF Feature

This feature helps you to program your oven by prompting the next step to be taken. When you become familiar with your oven, the prompt can be turned off.





* Default Mode.



Selecting Power & Cook Time

Example: To cook at MEDIUM power for 1 minute 30 seconds

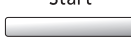
<p>1.  Press 3 times</p>	<ul style="list-style-type: none"> Press Micro Power button until the desired power level appears in the display window.
<p>2.  Rotate</p>	<ul style="list-style-type: none"> Set cooking Time using Time dial to 1 minute 30 seconds.
<p>3. </p>	<ul style="list-style-type: none"> Press Start button. <ul style="list-style-type: none"> ▶ Cooking will start. The time in the display window will count down.

Press	Power Level
once	HIGH
twice	MED-HIGH
3 times	MEDIUM
4 times	MED-LOW
5 times	DEFROST
6 times	LOW

Notes:

- For more than one stage cooking, repeat steps 1 and 2 for each stage of cooking before pressing **Start** button. The maximum number of stages for cooking is 3. When operating, two beeps will sound between each stage. Five beeps will sound at the end of the entire sequence.
- When selecting HIGH power for the first stage, you may begin at step 2.
- When selecting HIGH power, the maximum programmable time is 30 minutes. For other power levels, the maximum time is 1 hour and 30 minutes.
- For reheating, use HIGH power for liquids, MED-HIGH power for most foods and MEDIUM power for dense foods.
- For defrosting, use DEFROST power.



DO NOT OVERCOOK. This oven requires less time to cook than an older unit. Overcooking will cause food to dry out and may cause a fire. A microwave oven's cooking power tells you the amount of microwave power available for cooking.



Quick Min Feature

This feature allows you to set or add cooking time in 1 minute increments up to 10 minutes.

To Set Cooking Time:

<p>1. </p>	<ul style="list-style-type: none"> Press Quick Min button until the desired cooking time (up to 10 minutes) appears in the display window. Power Level is pre-set at HIGH.
<p>2. </p>	<p>Press Start button. Cooking begins and the time will count down. At the end of cooking, 5 beeps sound.</p>



Notes:

- If desired, you can use other power levels. Select desired power level before setting cooking time.
- After setting the time by **Quick Min** button, you cannot use Dial.
- Quick Min** button can be used to add more time during manual cooking.



Popcorn Feature

Example: To pop 3.5 oz. (99 g) of popcorn

<p>1.</p> <p>Popcorn</p> <p>Press once</p> 	<ul style="list-style-type: none"> Press Popcorn button until the desired size appears in the display window. <table border="1" data-bbox="444 426 788 580"> <thead> <tr> <th>Press</th> <th>Weight</th> </tr> </thead> <tbody> <tr> <td>once</td> <td>3.5 oz. (99 g)</td> </tr> <tr> <td>twice</td> <td>3.0 oz. (85 g)</td> </tr> <tr> <td>3 times</td> <td>1.75 oz. (50 g)</td> </tr> </tbody> </table>	Press	Weight	once	3.5 oz. (99 g)	twice	3.0 oz. (85 g)	3 times	1.75 oz. (50 g)
Press	Weight								
once	3.5 oz. (99 g)								
twice	3.0 oz. (85 g)								
3 times	1.75 oz. (50 g)								
<p>2.</p> <p>More/ Less</p> <p>Optional</p> 	<p>(see More/Less Feature.)</p>								
<p>3.</p> <p>Start</p> 	<ul style="list-style-type: none"> Press Start button. <ul style="list-style-type: none"> After several seconds, cooking time appears in the display window and begins to count down. 								

Notes on Popcorn Feature:

- Pop one bag at a time.
- Place bag in oven according to manufacturers' directions.
- Start with popcorn at room temperature.
- Allow popped corn to sit unopened for a few minutes.
- Open bag carefully to prevent burns, because steam will escape.
- Do not reheat unpopped kernels or reuse bag.

Note:

If popcorn is of a different weight than listed, follow instructions on popcorn package. **Never leave the oven unattended.** If popping slows to 2 to 3 seconds between pops, stop oven. **Overcooking can cause fire.**

Remarks:

When popping multiple bags one right after the other, the cooking time may vary slightly. This does not affect the popcorn results.



More/Less Feature

For Popcorn:

By using the **More/Less** button, the programs can be adjusted to cook popcorn for a longer or shorter time if desired.

- 1 tap = Adds approx. 10 secs
- 2 taps = Adds approx. 20 secs
- 3 taps = Subtracts approx. 10 secs
- 4 taps = Subtracts approx. 20 secs
- 5 taps = Original setting

Press **More/Less** button before pressing **Start** button.

For Auto Reheat/Cook:

Preferences for food doneness vary with each individual. After having used the **Auto Reheat/Cook** feature a few times, you may decide you would prefer your food cooked to a different doneness.

- 1 tap = More (Adds approx. 10% time)
- 2 taps = Less (Subtracts approx. 10% time)
- 3 taps = Original setting

Press **More/Less** button before pressing **Start** button.





Inverter Turbo Defrost Feature

This feature allows you to automatically defrost foods such as: meat, poultry and seafood simply by entering the weight.

Example: To defrost 1.5 pounds of meat

Place food on microwave safe dish.

1. 	<ul style="list-style-type: none"> • Press Inverter Turbo Defrost button.
2. Weight Dial  Rotate	<ul style="list-style-type: none"> • Set weight of the food using the Weight dial to 1.5 pounds.
3. 	<ul style="list-style-type: none"> • Press Start button. Defrosting will start. The time will count down. Higher weight foods will cause a signal midway through defrosting. If 2 beeps sound, turn over, rearrange foods or shield with aluminum foil.

Conversion Chart:

Follow the chart to convert ounces or hundredths of a pound into tenths of a pound. To use Inverter Turbo Defrost, enter the weight of the food in lbs. (1.0) and tenths of a lb. (0.1). If a piece of meat weighs 1.95 lbs. or 1 lb. 14 oz., enter 1.9 lbs.

Ounces	Hundredths of a Pound	Tenths of a Pound
0	.01 - .05	0.0
1 - 2	.06 - .15	0.1
3 - 4	.16 - .25	0.2
5	.26 - .35	0.3
6 - 7	.36 - .45	0.4
8	.46 - .55	0.5
9 - 10	.56 - .65	0.6
11 - 12	.66 - .75	0.7
13	.76 - .85	0.8
14 - 15	.86 - .95	0.9

Note:

The maximum weight for Inverter Turbo Defrost is 6 lbs. (3 kg).



Defrosting Tips & Techniques

Preparation For Freezing:

1. Freeze meats, poultry, and fish in packages with only 1 or 2 layers of food. Place wax paper between layers.
2. Package in heavy-duty plastic wraps, bags (labeled "For Freezer"), or freezer paper.
3. Remove as much air as possible.
4. Seal securely, date, and label.

To Defrost:

1. Remove wrapper. This helps moisture to evaporate. Juices from food can get hot and cook the food.
2. Set food in microwave-safe dish.
3. Place roasts fat-side down. Place whole poultry breast-side down.
4. Select power and minimum time so that items will be under-defrosted.
5. Drain liquids during defrosting.
6. Turn over (invert) items during defrosting.
7. Shield edges and ends if needed. (See Cooking Techniques).

After Defrosting:

1. Large items may be icy in the centre. Defrosting will complete during STANDING TIME.
2. Let stand, covered, following stand time directions on next page.
3. Rinse foods as indicated in the chart.
4. Items which have been layered should be rinsed separately or have a longer stand time.



Defrosting Tips & Techniques

(continued)



FOOD	MANUAL DEFROST TIME at P3 (min/kg) (min/lb)		DURING DEFROSTING	AFTER DEFROSTING	
	Stand Time	Rinse			
Fish and Seafood [up to 1.4 kg (3 lbs.)] Crabmeat	12	6	Break apart/Rearrange	5 min.	YES
Fish Steaks	8 to 12	4 to 6	Turn over		
Fish Fillets	8 to 12	4 to 6	Turn over/Rearrange/Shield ends		
Sea Scallops	8 to 12	4 to 6	Break apart/Remove defrosted pieces		
Whole fish	8 to 12	4 to 6	Turn over		
Meat Ground Meat	8 to 10	4 to 5	Turn over/Remove defrosted portion/Shield edges	10 min.	NO
Roasts [1.1-1.8 kg (2½-4 lbs.)]	8 to 16	4 to 8	Turn over/Shield ends and defrosted surface	30 min. in refrig.	
Chops/Steak	12 to 16	6 to 8	Turn over/Rearrange/Shield ends and defrosted surface	5 min.	
Ribs/T-bone	12 to 16	6 to 8	Turn over/Rearrange/Shield ends and defrosted surface		
Stew Meat	8 to 16	4 to 8	Break apart/Rearrange/Remove defrosted pieces		
Liver (thinly sliced)	8 to 12	4 to 6	Drain liquid/Turn over/ Separate pieces	-----	
Bacon (sliced)	8	4	Turn over	-----	
Poultry Chicken, Whole [up to 1.4 kg (3 lbs.)]	8 to 12	4 to 6	Turn over/Shield	20 min. in refrig.	YES
Cutlets	8 to 12	4 to 6	Break apart/Turn over/ Remove defrosted Pieces	5 min.	
Pieces	8 to 12	4 to 6	Break apart/Turn over/Shield	10 min.	
Cornish Hens	12 to 16	6 to 8	Turn over/Shield	20 min. in refrig.	
Turkey Breast [2.3-2.7 kg (5-6 lbs.)]	12	6	Turn over/Shield		



Grill Feature

This feature allows you to grill, crisp, or toast the surface of your food.

Example: To cook bread for 3 minutes by grill

<p>1.</p> <p>Grill</p>  <p>Press</p>	<ul style="list-style-type: none"> • Press Grill button.
<p>2.</p> <p>Time Dial</p>  <p>Rotate</p>	<ul style="list-style-type: none"> • Set grilling Time using Time dial to 3 minutes. (up to 1 hour and 30 minutes).
<p>3.</p> <p>Start</p> 	<ul style="list-style-type: none"> • Press Start button. ▶ Cooking will start. The time in the display window will count down.

Directions for Grilling

When grilling, heat is radiated from the two elements at the top of the oven. The Grilling elements do not require preheating. Grilling is particularly useful for reheating crispy foods such as fried chicken or chicken nuggets. It is also suitable for hot sandwiches and au gratin dishes. The oven supplies two kinds height wire rack for your choice. Use high feet wire rack for thin foods and use low feet wire rack for thick foods.

Place food to be grilled on Wire Rack and place Wire Rack on Flat Table. An oven-safe dish can be placed underneath Wire Rack to catch oil drippings from foods. Press **Grill** button, set the time and start the oven.

If needed, the food being grilled can be turned over after half the grilling time has elapsed. When the oven door is opened, the program is interrupted. Carefully take out wire rack using oven mitts, turn the food over, and place it back into oven. Close the door and restart oven. While grilling, the oven door can be opened at any time to check the food.

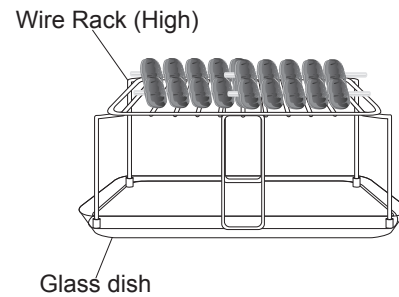

Caution:



Food and accessories will be hot after grilling. Use oven mitts when handling.



Combination Feature

This feature allows you to cook your food evenly and retain crispness as well as easy grilling of certain foods.

Example: To cook chicken pieces for 10 minutes by Combination 1.

1. Combination  Press	<ul style="list-style-type: none"> • Press Combination button once.
2. Time Dial  Rotate	<ul style="list-style-type: none"> • Set cooking Time using Time dial to 10 minutes. (up to 9 hours).
3. Start 	<ul style="list-style-type: none"> • Press Start button. ▶ Cooking will start. The time in the display window will count down.

Press	Power Level
once	Combination 1 (Grill power is HIGH, Microwave power is LOW)
twice	Combination 2 (Grill power is MEDIUM, Microwave power is MEDIUM)
3 times	Combination 3 (Grill power is LOW, Microwave power is HIGH)

Directions for combination cooking

The combination means that it is possible to combine the microwave and grill function for thawing, cooking, and heating foods. It's a good way for roasting foods by combining microwave and grill effectively. It's suitable for roasting poultry, meat and seafood. This function can ensure the foods cook evenly and retain their crispness as well as browning of certain foods. Please turn over the foods when half of the cooking time has elapsed, then continue cooking.

Place food to be cooked on an oven-safe dish and place the dish on Flat Table. Press **Combination** button to select desired power, set the time and start the oven. If needed, the food being cooked can be turned over after half the cooking time has elapsed. When the oven door is opened, the program is interrupted. Carefully take out the dish using oven mitts, turn the food over, and place it back into the oven. Close the door and restart oven. While cooking, the oven door can be opened at any time to check the food.

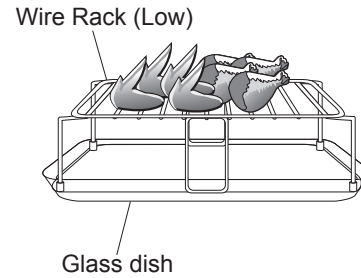

Caution:





1. Food and accessories will be hot after cooking. Use oven mitts when handling.
2. Do not use oven tray. Metal container cannot be placed directly on the wire rack. Insert a glass plate or microwave safe dish between metal container and wire rack.



Convection Feature

This feature offers a choice of convection temperature 100°F and 200°F ~ 475°F in 25°F increments (or 40°C and 100°C ~ 250°C in 10°C increments). Most baked items require preheating the oven. For quick selection of the most commonly used temperatures, the temperatures start at 350°F and count up to 475°F then 100°F and 200°F (or at 150°C and count up to 250°C then 40°C and 100°C).

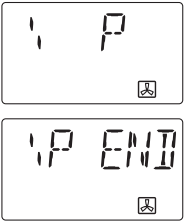
Example: To cook at 350°F for 20 minutes. Need preheating.

<p>1.</p> 	<ul style="list-style-type: none"> Press Convection button once.
<p>2.</p> 	<ul style="list-style-type: none"> Press Start button. ► Preheating will start.
	<ul style="list-style-type: none"> If you don't need preheating, eliminate Step 2. During preheating, "P" appears in the display window. Do not open the door. When preheating is completed, the oven will beep three times and "P END" will appear in the display window. If the oven door is not opened after preheating, the selected temperature will be maintained for 30 minutes including preheating. After 30 minutes, the oven will shut off automatically and beep five times.
<p>3.</p>  <p>Rotate</p>	<ul style="list-style-type: none"> After preheating, place food in the oven. Set the cooking time 20 minutes (up to 9 hours). If you don't need preheating, set the cooking time directly.
<p>4.</p> 	<ul style="list-style-type: none"> Press Start button. ► Cooking will start.

Notes:

- Always use oven mitts when removing the food and accessories after cooking as the oven and accessories will be very hot.
- This feature can be used for fermenting by setting 100°F (or 40°C) without preheating.
- To maintain the oven's components reliability, the convection oven temperature will automatically decrease to 400 °F (200 °C) when cooking over 20 minutes in a setting over 400 °F (200 °C).
- Do not preheat with Oven Tray.
- For recipes that do not require preheating, eliminate step 2.
- When the selected cooking time is less than one hour, the time counts down second by second.
- When the selected cooking time is more than one hour, the time counts down minute by minute until 1 hour remains. The timer will then count down second by second.
- Press **Convection** button during preheating or cooking to display the temperature you programmed.
- When using the Oven Tray, please insert into the rail as illustrated in the figure. Do not put the Oven Tray directly on top of rail or Flat Table to avoid the risk of fire.

Placement of Oven Tray

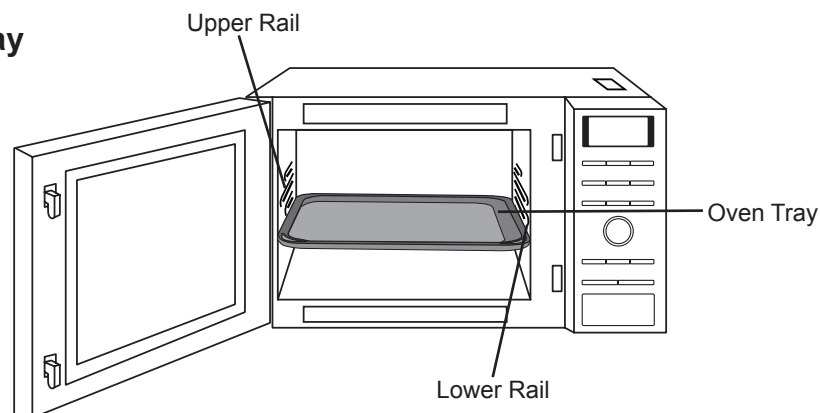







Auto Reheat Feature

This feature allows you to reheat 1 to 4 servings of cooked, refrigerated food without setting power and time.

Example: To reheat 2 servings of casserole

1.  Auto Reheat Press once	<ul style="list-style-type: none"> • Press Auto Reheat button.
2. Weight Dial  Rotate	<ul style="list-style-type: none"> • Set until the desired weight appears in the display window.
3.  More/Less Optional	(see More/Less Feature) (see page 19)
4.  Start	<ul style="list-style-type: none"> • Press Start button. ➤ Cooking begins and the time will count down.

servings	average serving size
1	6 oz (170 g)
2	8 oz (230 g)
3	12 oz (340 g)
4	16 oz (450 g)

Notes: For best results, follow these recommendations:





1. All foods must be previously cooked.
2. Foods should always be covered with lid or vented plastic wrap.
3. All foods should have a covered stand time of 3 to 5 minutes.
4. DO NOT reheat bread and pastry products using Auto Reheat. Use manual power and time instead.
5. DO NOT reheat beverages.
6. A plate of food is normally 3-4 servings.



Auto Cook Feature

These are tested and pre-timed (based on the power rating of this oven) for the quantity of food listed in the chart on page 26-27. Locale, power fluctuations and personal tastes are not taken into account. Should you prefer your food cooked differently, use power and time method shown on page 18.

Example: To cook 300 g (11 oz) of Frozen Vegetables

1.  Auto Menu (1-7) Press twice	<ul style="list-style-type: none"> • Press Auto Cook button until the desired food category appears in the display window.
2. Weight Dial  Rotate	Set Serving/Weight until the desired serving/weight appears in the display window.
3.  More/Less Optional	(see More/Less Feature) (see page 19)
4.  Start	<ul style="list-style-type: none"> • Press Start button. ➤ Cooking begins and the time will count down.



Auto Cook Chart

Recipe	Serving/Weight	Hints
1. Fresh Vegetables	100, 200, 300, 400 g (4, 7, 11, 14 oz)	All pieces should be the same size. Wash thoroughly, add 1 tbsp of water per ½ cup of vegetables, and cover with lid or vented plastic wrap. Do not salt/butter until after cooking. After 2 beeps, stir or rearrange.
2. Frozen Vegetables	200, 300, 400, 500g (7, 11, 14, 18 oz)	Wash thoroughly, add 1 tbsp of water per ½ cup of vegetables, and cover with lid or vented plastic wrap. Do not salt/butter until after cooking. (Not suitable for vegetables in butter or sauce.)
3. Beverages	1, 2 cups (250 ml, 500 ml)	This feature allows you to reheat 1 cup (250ml) or 2 cups (500ml) or room temperature beverages without setting power and time. Notes: <ol style="list-style-type: none">1. Use a microwave-safe cup.2. Heated liquids can erupt if not mixed with air. Do not heat liquids in your microwave oven without stirring before and halfway through heating.3. Care must be exercised not to overheat liquids when using the Beverage feature. It is programmed to give proper result when heating 1 cup (250ml) or 2 cups (500ml) of liquid, starting from room temperature. Overheating will cause an increased risk of scalding, or water eruption. Refer to page 4, item 18.
4. White Rice	½, 1, 1½ cups	Place white rice with hot tap water in a microwave-safe casserole dish. Cover with lid or vented plastic wrap. Let stand 5 to 10 minutes before serving.
5. Brown Rice	½, 1, 1½ cups	Place brown rice with hot tap water in a microwave-safe casserole dish. Cover with lid or vented plastic wrap. Let stand 5 to 10 minutes before serving.
6. Pasta	50, 100, 150, 200 g (2, 4, 5, 7 oz)	Place pasta with hot tap water in a microwave-safe casserole dish. Cover with lid or vented plastic wrap.
7. Fish	100, 200, 300, 400 g (4, 7, 11, 14 oz)	Arrange in a single layer. Cover with lid or vented plastic wrap.



Auto Cook Chart

(continued)

Recipe	Serving/Weight	Hints
8. Frozen Pizza	200, 400, 600 g (7, 14, 21 oz)	To preheat the oven, press Start button without food or oven tray in the oven. After 3 beeps, place the pizza on the oven tray and insert in the lower set of rails.
9. Frozen Pie	500, 1000 g (18, 35 oz)	To preheat the oven, press Start button without food. After 3 beeps, place the pie on the oven tray and insert in the lower set of rails.
10. Baked Potato	1, 2, 3, 4 pieces (230, 460, 690, 920 g)	Pierce each potato with a fork 6 times spacing around surface. Place potato (es) on the low wire rack with glass tray underneath. Turn over after 2 beeps. Let stand 5 minutes to complete cooking.
11. Roast Beef	600, 900, 1200 g (21, 32, 42 oz)	Place the marinated beef on the low wire rack with glass tray underneath. Turn over after 2 beeps. Let stand covered with aluminum foil for 5 to 10 minutes to complete cooking.
12. Roast Pork	600, 900, 1200 g (21, 32, 42 oz)	Place the marinated pork on the low wire rack with glass tray underneath. Turn over after 2 beeps. Let stand covered with aluminum foil for 5 to 10 minutes to complete cooking.
13. Whole Chicken	600, 900, 1800 g (21, 32, 64 oz)	Place the whole chicken on the low wire rack with glass tray underneath. Turn over after 2 beeps. Let stand covered with aluminum foil for 5 to 10 minutes to complete cooking.
14. Chicken Pieces	400, 600, 800, 1000 g (14, 21, 28, 35 oz)	Place the chicken pieces on the high wire rack with glass tray underneath. Turn over after 2 beeps. Let stand covered with aluminum foil for 5 to 10 minutes to complete cooking.



Timer Feature



This feature allows you to program the oven as a kitchen timer. It can also be used to program a standing time after cooking is completed and/or to program a delay start.

CAUTION:

If oven lamp is lit while using the timer feature, the oven is incorrectly programmed. Stop oven immediately and re-read instructions.





To Use as a Kitchen Timer:

Example: To count down 5 minutes.

1. Timer/ Clock 	• Press Timer/Clock button once.
2. Time Dial  Rotate	• Set 5 minutes using Time dial. (up to 1 hour and 30 minutes).
3. Start 	• Press Start button. ▶ Time will count down without oven operating.





To Set Stand Time:

Example: To cook at MEDIUM power for 3 minutes, with stand time of 5 minutes.

1. MicroPower  Press 3 times	• Press 3 times. (see page 18 for directions).
2. Time Dial  Rotate	Set 3 minutes using Time dial.
3. Timer/ Clock 	• Press Timer/Clock button once.
4. Time Dial  Rotate	• Set 5 minutes using Time dial (up to 1 hour and 30 minutes).
5. Start 	• Press Start button. ▶ Cooking will start. After cooking, stand time will count down without oven operating.

To Set Delay Start:

Example: To delay the start of cooking for 5 minutes, and cook at MEDIUM power for 3 minutes.

1. Timer/ Clock 	• Press Timer/Clock button once.
2. Time Dial  Rotate	• Set 5 minutes using Time dial. (up to 1 hour and 30 minutes).
3. Micro Power  Press 3 times	• Press 3 times. (see page 18 for directions).
4. Time Dial  Rotate	Set 3 minutes using Time dial.
5. Start 	• Press Start button. ▶ Delay time will count down. Then cooking will start.

Notes:

1. When each stage finishes, a two-beep signal sounds. At the end of the program, the oven will beep five times.
2. If the oven door is opened during Stand Time, Kitchen Timer or Delay Time, the time on the display will continue to count down.
3. Stand time and Delay start cannot be programmed before any automatic Function. This is to prevent the starting temperature of food from rising before defrosting or cooking begins. A change in starting temperature could cause inaccurate results.



Microwave Shortcuts

FOOD	POWER	TIME (in mins.)	DIRECTIONS
To separate refrigerated Bacon , 450 g (1 pound)	HIGH	30 sec.	Remove wrapper and place in microwave safe dish. After heating, use a plastic spatula to separate slices.
To soften Brown Sugar 1 cup (250 ml)	HIGH	20 - 30 sec.	Place brown sugar in microwave safe dish with a slice of bread. Cover with lid or plastic wrap.
To soften refrigerated Butter , 1 stick, 110 g (¼ pound)	MED-LOW	1	Remove wrapper and place butter in a microwave safe dish.
To melt refrigerated Butter , 1 stick, 110 g (¼ pound)	MEDIUM	1½ - 2	Remove wrapper and place butter in a microwave safe dish covered with lid or vented plastic wrap.
To melt Chocolate , 1 square, 28 g (1 oz.)	MEDIUM	1 - 1½	Remove wrapper and place chocolate in a microwave safe dish. After heating, stir until completely melted.
To melt Chocolate , ½ cup (125 ml) chips	MEDIUM	1 - 1½	<i>Note: Chocolate holds its shape even when softened.</i>
To toast Coconut , ½ cup (125 ml)	HIGH	1	Place in a microwave safe dish. Stir every 30 seconds.
To soften Cream Cheese , 225 g (8 oz.)	MED-LOW	1 - 2	Remove wrapper and place in a microwave safe bowl.
To brown Ground Beef , 450 g (1 pound)	HIGH	4 - 5	Crumble into a microwave safe colander set into another dish. Cover with plastic wrap. Stir twice. Drain grease.
To cook Vegetables , Fresh (225 g) (½ pound)	MED-HIGH	3½ - 4	All pieces should be the same size. Wash thoroughly, add 1 tbsp of water per ½ cup of vegetables, and cover with lid or vented plastic wrap. Do not salt/butter until after cooking.
Frozen (285 g) (10 oz.)	MED-HIGH	3½ - 4	Wash thoroughly, add 1 tbsp of water per ½ cup of vegetables, and cover with lid or vented plastic wrap. Do not salt/butter until after cooking. (Not suitable for vegetables in butter or sauce.)
Canned (430 g) (15 oz.)	MED-HIGH	3½ - 4	Empty contents into microwave safe serving bowl. Cover with lid or vented plastic wrap.



Microwave Shortcuts

(continued)

FOOD	POWER	TIME (in mins.)	DIRECTIONS
To cook baked Potato , (170 - 225 g) (6 - 8 oz. each) 1 2	MED-HIGH MED-HIGH	3½ - 4 6 - 7	Pierce each potato with a fork 6 times spacing around surface. Place potato or potatoes on a paper towel, lined on the Flat Table, at least 1 inch (2.5 cm) apart. Do not cover. Turn over after the 2 beeps signal sounds. Let stand 5 minutes to complete cooking. Cooking arrangement: Arrange 1 or 2 pieces on a paper towel, lined in center of the Flat Table. Arrange 3 or 4 pieces evenly in a circular pattern on a paper towel, lined in center of the Flat Table.
To steam Hand Towels - 4	HIGH	20 - 30 sec.	Soak in water, then wring out excess. Place on a microwave safe dish. Heat. Present immediately.
To soften Ice Cream , 2 qt. (½ gallon)	MED-LOW	1 - 1½	Check often to prevent melting.
Cup of liquid To boil water, broth , etc. 1 cup, 250 ml (8 oz.) 2 cups, 500 ml (16 oz.)	HIGH	1½ - 2 2½ - 3	Heated liquids can erupt if not stirred. Do not heat liquids in microwave oven without stirring before heating.
Cup of liquid To warm Beverage , 1 cup, 250 ml (8 oz.) 2 cups, 500 ml (16 oz.)	MED-HIGH	1½ - 2 2½ - 3	
To roast Nuts , 1½ cups (375 ml)	HIGH	3 - 4	Spread nuts into a 23 cm (9-inch) microwave safe pie plate. Stir occasionally.
To toast Sesame Seeds , ¼ cup (60 ml)	HIGH	2 - 2½	Place in a small microwave safe bowl. Stir twice.
To skin Tomato , (one at a time)	HIGH	30 sec.	Place tomato into a microwave safe bowl containing boiling water. Rinse and peel. Repeat for each tomato.
To remove Cooking Odours	HIGH	5	Combine 1 to 1½ cups (250 - 375 ml) water with the juice and peel of one lemon in a 2-quart microwave safe bowl. After water finishes boiling, wipe interior of oven with a cloth.

Food Characteristics

Bone and Fat

Both bone and fat affect cooking. Bones may cause irregular cooking. Meat next to the tips of bones may overcook while meat positioned under a large bone, such as a ham bone, may be undercooked. Large amounts of fat absorb microwave energy and the meat next to these areas may overcook.



Density

Porous, airy foods such as breads, cakes or rolls take less time to cook than heavy, dense foods such as potatoes and roasts. When reheating donuts or other foods with different centres be very careful. Certain foods have centres made with sugar, water, or fat and these centres attract microwaves (for example, jelly donuts). When a jelly donut is heated, the jelly can become extremely hot while the exterior remains warm to the touch. This could result in a burn if the food is not allowed to cool properly in the centre.

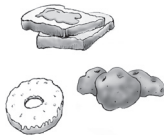

Quantity

Two potatoes take longer to cook than one potato. As the quantity of the food decreases so does the cooking time. Overcooking will cause the moisture content in the food to decrease and a fire could result. Never leave microwave unattended while in use.



Shape

Uniform sizes heat more evenly. The thin end of a drumstick will cook more quickly than the meaty end. To compensate for irregular shapes, place thin parts toward the centre of the dish and thick pieces toward the edge.



Size

Thin pieces cook more quickly than thick pieces.



Starting Temperature

Foods that are at room temperature take less time to cook than if they are chilled, refrigerated, or frozen.



Cooking Techniques

Piercing

Foods with skins or membranes must be pierced, scored or have a strip of skin peeled before cooking to allow steam to escape. Pierce clams, oysters, chicken livers, whole potatoes and whole vegetables. Whole apples or new potatoes should have a 1-inch strip of skin peeled before cooking. Score sausages and frankfurters. Do not Cook/Reheat whole eggs with or without the shell. Steam built up in whole eggs may cause them to explode, and possibly damage the oven or cause injury. Reheating SLICED hard-boiled eggs and cooking SCRAMBLED eggs is safe.



Browning

Foods will not have the same brown appearance as conventionally cooked foods or those foods which are cooked utilizing a browning feature. Meats and poultry may be coated with browning sauce, Worcestershire sauce, barbecue sauce or shake-on browning sauce. To use, combine browning sauce with melted butter or margarine and brush on before cooking. For quick breads or muffins, brown sugar can be used in the recipe in place of granulated sugar, or the surface can be sprinkled with dark spices before baking.



Spacing

Individual foods, such as baked potatoes, cupcakes and appetizers, will cook more evenly if placed in the oven equal distances apart. When possible, arrange foods in a circular pattern.





Cooking Techniques

(continued)

Covering

As with conventional cooking, moisture evaporates during microwave cooking. Casserole lids or plastic wrap are used for a tighter seal. When using plastic wrap, vent the plastic wrap by folding back part of the plastic wrap from the edge of the dish to allow steam to escape. Loosen or remove plastic wrap as recipe directs for stand time. When removing plastic wrap covers, as well as any glass lids, be careful to remove them away from you to avoid steam burns. Various degrees of moisture retention are also obtained by using wax paper or paper towels.

Shielding

Thin areas of meat and poultry cook more quickly than meaty portions. To prevent overcooking, these thin areas can be shielded with strips of aluminum foil. Wooden toothpicks may be used to hold the foil in place.

▲ CAUTION is to be exercised when using foil. Arcing can occur if foil is too close to oven wall or door and damage to your oven will result.

Cooking time

A range of cooking time is given in each recipe. The time range compensates for the uncontrollable differences in food shapes, starting temperature, and regional preferences. Always cook food for the minimum cooking time given in a recipe and check for doneness. If the food is undercooked, continue cooking. It is easier to add time to an undercooked product. Once the food is overcooked, nothing can be done.

Stirring

Stirring is usually necessary during microwave cooking. Always bring the cooked outside edges toward the centre and the less cooked centre portions toward the outside of the dish.

Rearranging

Rearrange small items such as chicken pieces, shrimp, hamburger patties or pork chops. Rearrange pieces from the edge to the centre and pieces from the centre to the edge of the dish.

Turning

It is not possible to stir some foods to distribute the heat evenly. At times, microwave energy will concentrate in one area of the food. To help ensure even cooking, these foods need to be turned. Turn over large foods, such as roasts or turkeys, halfway through cooking.

Stand Time

Most foods will continue to cook by conduction after the microwave oven is turned off. In meat cookery, the internal temperature will rise 3 °C to 8 °C (5 °F to 15 °F), if allowed to stand, tented with foil, for 10 to 15 minutes. Casseroles and vegetables need a shorter amount of standing time, but this standing time is necessary to allow foods to complete cooking to the centre without overcooking on the edges.

Test for Doneness

The same tests for doneness used in conventional cooking may be used for microwave cooking. Meat is done when fork-tender or splits at fibers. Chicken is done when juices are clear yellow and drumstick moves freely. Fish is done when it flakes and is opaque. Cake is done when a toothpick or cake tester is inserted and comes out clean.

ABOUT FOOD SAFETY AND COOKING TEMPERATURE

- Check foods to see that they are cooked at the recommended temperatures.

TEMP	FOOD
71 °C (160 °F)	... for fresh pork, ground meat, boneless white poultry, fish, seafood, egg dishes and frozen prepared food.
74 °C (165 °F)	... for leftover, ready-to-reheat refrigerated, and deli and carryout "fresh" food.
77 °C (170 °F)	... white meat of poultry.
82 °C (180 °F)	... dark meat of poultry.

To test for doneness, insert a meat thermometer in a thick or dense area away from fat or bone. NEVER leave the thermometer in the food during cooking, unless it is approved for microwave oven use.



Before Requesting Service

THESE THINGS ARE NORMAL

The oven causes interference with my TV.	Some radio and TV interference might occur when you cook with the microwave oven. This interference is similar to the interference caused by small appliances such as mixers, vacuums, hair dryers, etc. It does not indicate a problem with your oven.
Steam accumulates on the oven door and warm air comes from the oven vents.	During cooking, steam and warm air are given off from the food. Most of the steam and warm air are removed from the oven by the air which circulates in the oven cavity. However, some steam will condense on cooler surfaces such as the oven door. This is normal and safe. Steam will disappear after the oven has cooled down.
I accidentally operated my microwave oven without any food in it.	Operating the oven empty for a short time will not damage the oven. However, we do not recommend this to be done.
There are humming and clicking noises from my oven when I cook using Combination.	These noise occur as the oven automatically switches from microwave power to Grill, to create the Combination setting. This is normal.
The oven has an odour and generates smoke when using Convection, Combination and Grill function.	It is essential that your oven is wiped out regularly particularly after cooking using Convection, Combination or Grill. Any fat and grease that builds up on the roof and walls of the oven will begin to smoke if not cleaned.
The fan motor continues operating after cooking is over.	After using the microwave oven, the fan motor will operate for several minutes to cool the electric components.
Some smoke is given off from the cavity when using grill, combination or convection for the first time.	This is caused by the excessive oil in the cavity and oil used for rust protection.



Before Requesting Service

(continued)

PROBLEM	POSSIBLE CAUSE	REMEDY
Oven will not turn on.	The oven is not plugged in securely.	Remove plug from outlet, wait 10 seconds and re-insert.
	Circuit breaker or fuse is tripped or blown.	Contact the specified service centre.
	There is a problem with the outlet.	Plug another appliance into the outlet to check if the outlet is working.
Oven will not start cooking.	The door is not closed completely.	Close the oven door securely.
	Start button was not pressed after programming.	Press Start button.
	Another program has already been entered into the oven.	Press Stop/Reset button to cancel the previous program and program again.
	The program has not been entered correctly.	Program again according to the Operating Instructions.
	Stop/Reset button has been pressed accidentally.	Program oven again.
"HOT" appears in the display window.	The cavity is overheated.	Operate again after it cools down.
The "LOCK" and "🔑" appears in the display window.	The Child Safety Lock was activated by pressing Start button 3 times.	Deactivated Lock by pressing Stop/Reset button 3 times.
"H97" or "H98" appears in the display window.	The display indicates a problem with microwave generation system.	Contact the specified service centre.
"DEMO MODE PRESS ANY KEY" appears in the display window.	When the oven is in demonstration mode, microwave doesn't emit.	Press Micro Power button once, press Start button 4 times then press Stop/Reset button 4 times.

If it seems there is a problem with the oven, contact an authorised Service Centre.

Warranty

Panasonic Canada Inc.

5770 Ambler Drive, Mississauga, Ontario L4W 2T3

PANASONIC PRODUCT – LIMITED WARRANTY

Panasonic Canada Inc. warrants this product to be free from defects in material and workmanship under normal use and for a period as stated below from the date of original purchase agrees to, at its option either (a) repair your product with new or refurbished parts, (b) replace it with a new or a refurbished equivalent value product, or (c) refund your purchase price. The decision to repair, replace or refund will be made by Panasonic Canada Inc.

Microwave Oven: Two (2) years, parts and labour (Carry-in Service). Additional three (3) year warranty on the magnetron (parts only, labour extra).

In-home Service applies to Convection, Over-The-Range and Stainless Steel ovens only.

In-home Service will be carried out only to locations accessible by roads and within 50 km of an authorized Panasonic service facility.

This warranty is given only to the original purchaser, or the person for whom it was purchased as a gift, of a Panasonic brand product mentioned above sold by an authorized Panasonic dealer in Canada and purchased and used in Canada, which product was not sold "as is", and which product was delivered to you in new condition in the original packaging.

IN ORDER TO BE ELIGIBLE TO RECEIVE WARRANTY SERVICE HEREUNDER, A PURCHASE RECEIPT OR OTHER PROOF OF DATE OF ORIGINAL PURCHASE, SHOWING AMOUNT PAID AND PLACE OF PURCHASE IS REQUIRED

LIMITATIONS AND EXCLUSIONS

This warranty ONLY COVERS failures due to defects in materials or workmanship, and DOES NOT COVER normal wear and tear or cosmetic damage. The warranty ALSO DOES NOT COVER damages which occurred in shipment, or failures which are caused by products not supplied by Panasonic Canada Inc., or failures which result from accidents, misuse, abuse, neglect, mishandling, misapplication, alteration, faulty installation, set-up adjustments, misadjustment of consumer controls, improper maintenance, power line surge, lightning damage, modification, introduction of sand, humidity or liquids, commercial use such as hotel, office, restaurant, or other business or rental use of the product, or service by anyone other than a Authorized Servicer, or damage that is attributable to acts of God.

Over-The-Range cooktop light bulbs are excluded from coverage under this warranty.

THIS EXPRESS, LIMITED WARRANTY IS IN LIEU OF ALL OTHER WARRANTIES, EXPRESS OR IMPLIED, INCLUDING ANY IMPLIED WARRANTIES OF MERCHANTABILITY AND FITNESS FOR A PARTICULAR PURPOSE. IN NO EVENT WILL PANASONIC CANADA INC. BE LIABLE FOR ANY SPECIAL, INDIRECT OR CONSEQUENTIAL DAMAGES RESULTING FROM THE USE OF THIS PRODUCT OR ARISING OUT OF ANY BREACH OF ANY EXPRESS OR IMPLIED WARRANTY. (As examples, this warranty excludes damages for lost time, travel to and from the Authorized Servicer, loss of or damage to media or images, data or other memory or recorded content. This list of items is not exhaustive, but for illustration only.)

In certain instances, some jurisdictions do not allow the exclusion or limitation of incidental or consequential damages, or the exclusion of implied warranties, so the above limitations and exclusions may not be applicable. This warranty gives you specific legal rights and you may have other rights which vary depending on your province or territory.

WARRANTY SERVICE

For product operation and information assistance, please contact:

PRODUCT OPERATION ASSISTANCE

Customer Care Centre: Telephone #: 1-800-561-5505
Fax #: (905) 238-2360
Email link: "Support → contact us → email" on www.panasonic.ca

PRODUCT REPAIRS

Please locate your nearest Authorized Servicentre.

Link: "Support → Panasonic Servicentre® locator" on www.panasonic.ca

IF YOU SHIP THE PRODUCT TO A SERVICENTRE

Carefully pack and send prepaid, adequately insured and preferably in the original carton.
Include details of the defect claimed, and proof of date of original purchase.

Quick Guide to Operation

Feature	How to Operate
To Set Clock (page 17)	<p>Press twice. → Time Dial Rotate Enter time of day. → Timer/Clock Press once.</p>
To Use Child Safety Lock (page 17)	<p>To Set: Press 3 times.</p> <p>To Cancel: Press 3 times.</p>
To set Power and Time (page 18)	<p>Press to select Power Level. → Time Dial Rotate Set cooking time. → Start Press once.</p>
To cook using Quick Min (page 18)	<p>(up to 10 min.) → Start Press once.</p>
To cook using Popcorn (page 19)	<p>Select weight. → (More/Less)* *Optional. → Start Press once.</p>
To defrost using Inverter Turbo Defrost (page 20)	<p>Press once. → Weight Dial Rotate Set weight. → Start Press once.</p>
To cook using Grill (page 22)	<p>Press once. → Time Dial Rotate Set the cooking time. → Start Press once.</p>
To cook using Combination (page 23)	<p>Press to select power level. → Time Dial Rotate Set the cooking time. → Start Press once.</p>
To cook using Convection (page 24)	<p>Press to select cooking temperature. → (Start)* *Optional. → Time Dial Rotate Set the cooking time. → Start Press once.</p>

Quick Guide to Operation

(continued)

Feature	How to Operate
<p>To reheat using Auto Reheat (page 25)</p>	<p>Auto Reheat → Weight Dial → (More/Less)* → Start</p> <p>Press once. Rotate Select serving. *Optional. Press once.</p>
<p>To reheat using Auto Cook (page 25)</p>	<p>Auto Menu (1-7) or Auto Menu (8-14) → Weight Dial → (More/Less)* → Start</p> <p>Select food number. Rotate Select serving/weight. *Optional. Press once.</p>
<p>To use as a Kitchen Timer (page 28)</p>	<p>Timer/Clock → Time Dial → Start</p> <p>Press once. Rotate Set time. Press once.</p>
<p>To set Stand Time (page 28)</p>	<p>Input up to 2 stage cooking programs. → Timer/Clock → Time Dial → Start</p> <p>Press once. Rotate Set time. Press once.</p>
<p>To set Delay Start (page 28)</p>	<p>Timer/Clock → Time Dial → Input up to 2 stage cooking programs. → Start</p> <p>Press once. Rotate Set time. Press once.</p>



Specifications

Model Number:		NN-CF770M
Power Source:		120 V, 60 Hz
Power Consumption:	Microwave	900 W (Initial Maximum Input Power: 1550 W)
	Heater	1,050 W
	Combination	1,050 W
	Convection	1,450 W
Cooking Power:	Microwave*	1,000 W
	Heater	1,000 W
	Convection	1,400 W
Outside Dimensions (W x H x D):		20 ^{13/16} " x 12 ^{13/16} " x 19 ^{7/16} " (529 mm x 326 mm x 494 mm)
Oven Cavity Dimensions (W x H x D):		13 ^{15/16} " x 8" x 13 ^{1/2} " (354 mm x 205 mm x 343 mm)
Cavity Volume:		27 L
Operating Frequency:		2,450 MHz
Net Weight:		Approx. 17.5 kg

Trim Kit

Model Number:	NN-TK510CSAP
Outside Dimensions (W x H):	23 ^{7/16} " x 16" (595 mm x 407 mm)
Cabinet Opening (W x H x D):	22 ^{1/8} " x 15 ^{1/2} " x 18 ^{7/8} " (562 mm x 395 mm x 480 mm)

*IEC Test procedure

Specifications subject to change without notice.

User's Record

The serial number of this product may be found on the left side of the control panel. You should note the model number and the serial number of this oven in the space provided and retain this book as a permanent record of your purchase for future reference.

Model No. _____

Serial No. _____

Date of Purchase _____