

User Manual

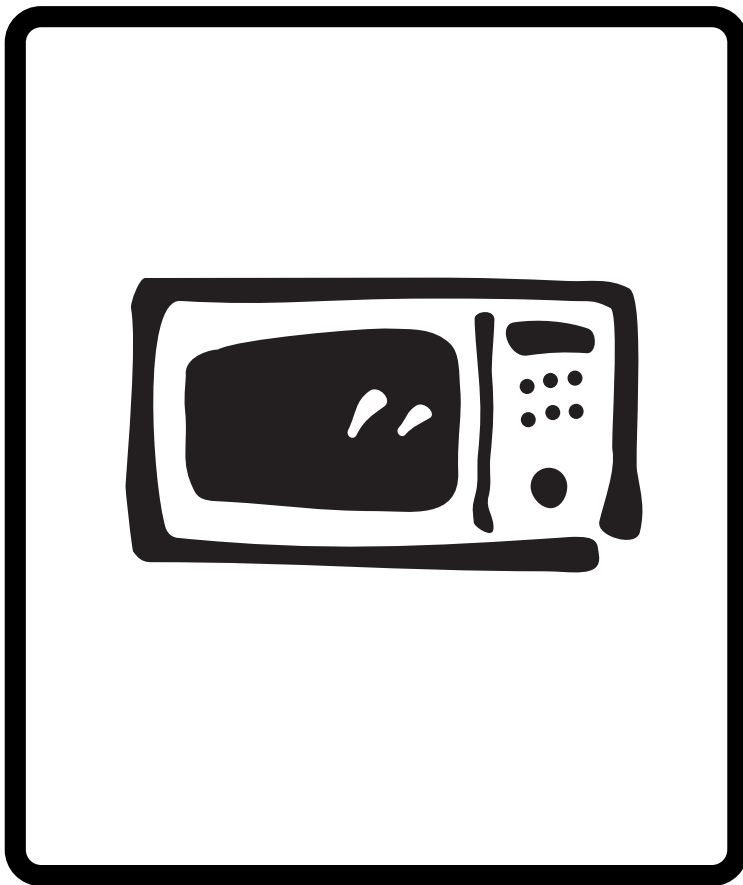

Model MOFF700W

MOFFAT 

Contents

Before using your microwave oven	4
Safety instructions	4
– Utensil safety	4
– Testing suitability of cookware	5
– Food safety	5
– Oven utensils and accessories guide	6
Technical data	6
Getting Started	7
– Unpacking	7
Installation	7
– Connecting to the mains	7
Electrical connections	8
How to operate your microwave oven	9
– Name and function of parts	9
– Turntable Installation	9
– Control panel	10
– MAFF Rating	10
– Microwave Cooking	11
– Microwave Power Setting Guide	11
– Defrosting instructions using 120W	12
– Microwave Hints	13
– Care and cleaning	14
– Cleaning the accessories (turntable and support)	14
– Cleaning the interior	14
– Cleaning the exterior	14
Aftersales Service	14

Congratulations on the purchase of your new Microwave Oven

Thank you for having chosen a Moffat product. We are convinced that you will find your new microwave oven very useful and that it will be of great help to you. As with all new kitchen appliances, it will take some time to learn all the new functions and features, but with time, this oven will become indispensable to you.

Before using your Microwave Oven

Read through the instruction manual carefully and ensure that you follow the recommendations given, these instructions have been prepared so that you get the best from your new Moffat Microwave Oven. It is important that this instruction book is retained with the appliance for future reference. Should the appliance be sold or transferred to another owner, or if you move house and leave the appliance, always ensure that the book is supplied with the appliance so that the new owner can be acquainted with the functioning of the appliance and the relevant warnings.

Safety Instructions

- The built-in safety interlock switches prevent the microwave oven from operating when the door is open.
- Do not tamper with them, or attempt to operate the oven with the door open as open door operation can result in exposure to microwave energy.
- Do not allow food spills or cleaner residue to accumulate on door sealing surfaces. See the Cleaning and Care section for cleaning instructions.
- Do not operate the oven if it is damaged until it has been repaired by qualified service personnel.
- It is particularly important that the oven door closes properly and that there is no damage to the: (1) door (warped), (2) hinges and latches (broken or insecure), (3) door seals and sealing surface.
- Under no circumstances should you attempt to repair the appliance yourself. Repairs carried out by inexperienced persons may cause injury or serious malfunctioning. Contact your local Service Force Centre.
- Do not remove the outer case, door or control panel at any time. Doing so may cause exposure to extremely high voltage.
- Install or locate this oven only in accordance with **“INSTALLATION INSTRUCTIONS”** found in this manual.
- Use the appliance for its intended use as described in this manual. Do not use corrosive chemicals in this appliance. This type of oven is specifically designed to heat, cook, or defrost food. It is not designed for industrial or laboratory use neither for commercial use as this will invalidate the guarantee.
- Do not operate the oven empty. If food or water is not present to absorb the microwave energy, the magnetron tube can be damaged.
- Close supervision is necessary when the oven is used by children.
- Do not store this appliance outdoors. Do not use this product near water.
- Do not attempt to dry clothing or newspapers in the microwave oven. These items can ignite.
- Do not use the cavity for storage purposes. Do not leave paper products, cooking utensils, or food in the cavity when not in use.

Utensil safety

Most glass, glass ceramic and heat-resistant glassware utensils are excellent for use in the microwave oven. Although microwave energy will not heat most glass and ceramic items, these utensils can become hot as heat transfers from the food to the container. The use of oven gloves to remove dishes is recommended.

Testing suitability of cookware

- Place the cookware in the cavity along with a glass half full of water. Heat on 700 W (100%) for one minute. If the cookware feels hot, you should not use it. If it is just slightly warm, you can use it for reheating but not for cooking. If the dish is room temperature, it is suitable for microwave cooking.
- Paper napkins, wax paper, paper towels, plates, cups, cartons, freezer wrap and cardboard are great convenience utensils. Always be sure containers are filled with food to absorb energy and thus avoid the possibility of overheating.
- Many plastic dishes, cups, freezer containers and plastic wraps may be used in the microwave oven. Follow manufacturer's instructions when using plastics in the oven. Avoid using plastic utensils with foods that have high fat or sugar content since these foods reach high temperatures and could melt some plastics.
- Do not leave oven unattended, and look at it from time to time when heating or cooking food in plastic, paper or other combustible containers. If smoke is observed, keep door closed, switch the oven off or disconnect oven until smoke stops.
- Metal utensils and utensils with metallic trim should not be used in the microwave oven, unless specifically recommended for microwave use.
- Containers with restricted openings, such as bottles, should not be used for microwave cooking.
- Use caution when removing a lid or cover from a dish to avoid steam burns.

Food safety

- Do not heat food in a can in the microwave oven. Always remove the food to a suitable container.
- Deep fat frying should not be done in the microwave oven, because the fat temperature cannot be controlled, hazardous situations can result.
- Popcorn may be prepared in the microwave oven, but only in special packages or utensils designed specifically for this purpose. This cooking operation should never be un-attended.
- Pierce foods with non-porous skins or membranes to prevent steam build-up and bursting. Apples, potatoes, chicken livers, and egg yolks are examples of items that should be pierced.

WARNING: When heating liquids, e.g. soups, sauces and beverages in your microwave oven, overheating the liquid beyond boiling point can occur without evidence of bubbling. This could result in a sudden boil over of the hot liquid. To prevent this possibility the following steps should be taken:

1. Avoid using straight-sided containers with narrow necks.
 2. Do not overheat.
 3. Stir the liquid before placing the container in the oven and again halfway through the heating time.
 4. After heating, allow to stand in the oven for a short time, stirring again before carefully removing the container.
- Some products such as whole eggs and sealed containers – for example, closed glass jars – may explode and should not be heated in this oven. Occasionally, poached eggs may explode during cooking. Always pierce the yolk, then cover and allow the standing time of one minute before removing cover.

NOTE:

- Do not force the turntable to rotate by hand. This may cause malfunctioning.
- Arcing in the oven during microwave operation usually occurs from use of metallic utensils. Continuous arcing, however, can damage the unit. Stop the programme and check the utensil.
- Care should be taken not to obstruct any air vents located on the top, rear, side and bottom of the oven.

Do not use this oven for commercial purposes.

This oven is made for domestic use only.

Keep these instructions

Oven utensils and accessories guide

A variety of Utensils and Materials may be used for cooking in your microwave oven. For your safety and to prevent damaging utensils and your oven choose, appropriate utensils and materials for each cooking method.

The list below is a general guide.

Material	Utensils	Microwave Cooking
Ceramic & Glass	Corning ware	YES
	Heat resistant glass ware	YES
	Glass ware with metal decoration	NO
	Lead crystal glass	NO
China	Without metal decoration	YES
Pottery		YES
Plastic	Microwave oven heat-proof wear	YES
	Plastic wrap	YES
Metal	Metal baking pan	NO
	Aluminium foil*	YES
Paper	Cups, plates, towels	YES
Waxed Paper		YES
Wood		NO
Accessories	Turntable	YES
	Turntable support	YES

YES: Utensils and accessories to use

NO: Utensils and accessories to avoid

***NOTE:** Use aluminium foil only for shielding purposes, overuse may cause arcing.

Technical data

Overall dimension	Weight 13.5 kg
Width 458 mm	Volume 17 Litre
Depth 296 mm	
Height 375 mm	Power source 220-240V, 50 Hz
Cavity dimension	Fuse 10A
Width 320 mm	Power consumption 1080W
Depth 183 mm	
Height 288 mm	Power output 700W
	MAFF Rating Category C

GETTING STARTED

Unpacking

N.B. When you unpack the oven, check that the product is free from damage. Damage or any missing parts must be reported immediately to the retailer. The oven, parts of the oven or the accessories may be wrapped by a protection foil. If so, you must remove this foil before using the oven. Do not leave packing material so that small children can play with it. This can be hazardous.

Installation

1. Remove any promotion label from the door.
2. Install the oven on a flat, level surface. The surface must be strong enough to safely bear the weight (13.5 kg) of the oven, and the contents. To avoid the possibility of causing vibration or noise the oven must be in a stable position.
3. Keep the oven away from heat and water. Exposure to heat and water can lower oven efficiency and lead to malfunctioning, so be sure to install the oven away from heat and water sources.
4. Do not block air vents on the top and the sides of the cabinet and also do not place any articles on the top of the oven. If air vents are blocked during operation, the oven may overheat, and this may lead to malfunctioning. Hot air escapes from the vents, so be sure not to obstruct it or let curtains come between the oven and the rear wall.
5. Place the oven as far away from radios and TV's as possible. This oven does conform to EEC requirements* of radio interference suppression, but some interference may occur if it is placed too close to a radio or TV, so keep them as far apart as possible.
6. If positioned in a corner, leave a gap of at least 5,0 cm from the walls to meet ventilation demands.

Important! The oven can be placed almost anywhere in the kitchen. Make sure the oven is placed on a flat, level surface and that vents as well as the surface underneath the oven are not blocked (for sufficient ventilation).

* This appliance conforms to the requirements of EEC Radio Interference Directive 87/308/EEC.

Connecting to the mains

The oven is delivered with the power cord and a plug for 220-240V, 50Hz, earthed socket outlet. Earth protection minimises the risks should a short-circuit occur. Check to ensure the voltage of the oven matches the supply.

N.B. If the oven is connected to the socket via an extension cord, make sure the cord is earthed.

WARNING! This appliance must not be used on a non-earth protected power supply.

Contact an electrician if you are uncertain regarding electrical connection of the oven or provision of earth protection of the supply.

This appliance must be earthed. If this appliance is fitted with a non-rewireable plug for which your socket is unsuitable, the plug should be cut off and the appropriate plug fitted. If it is necessary to change the fuse in a non-rewireable plug, the fuse cover must be refitted. If the fuse cover is lost or damaged, the plug must not be used until a replacement is obtained.

Electrical connections

WARNING! THIS APPLIANCE MUST BE EARTHED.

The manufacturer declines any liability should this safety measure not be observed.

- If the plug that is fitted to your appliance is not suitable for your socket outlet, it must be cut off and the appropriate plug fitted.
- Remove the fuse from the cut off plug. The cut off plug should then be disposed of to prevent the hazard of shocks in case it should be plugged into a 13 Amp socket in another part of your home.

IMPORTANT

The wires in the mains lead are coloured in accordance with the following code:

GREEN AND YELLOW
BLUE
BROWN

EARTH
NEUTRAL
LIVE

If you fit your own plug, the colours of the wires in the mains lead of your appliance may not correspond with the markings identifying the terminals in your plug, proceed as follows:

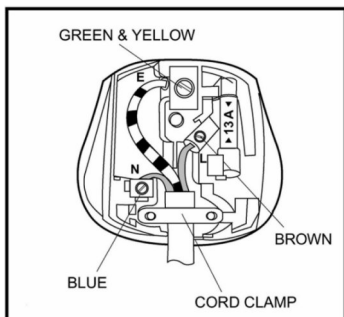

- Connect the green and yellow (earth) wire to the terminal in the plug which is marked with the letter "E" or the earth symbol (\equiv) or coloured green and yellow.
- Connect the blue (neutral) wire to the terminal in the plug which is marked with the letter "N" or coloured black.
- Connect the brown (live) wire to the terminal in the plug which is marked with the letter "L" or coloured red.

How to operate your microwave oven

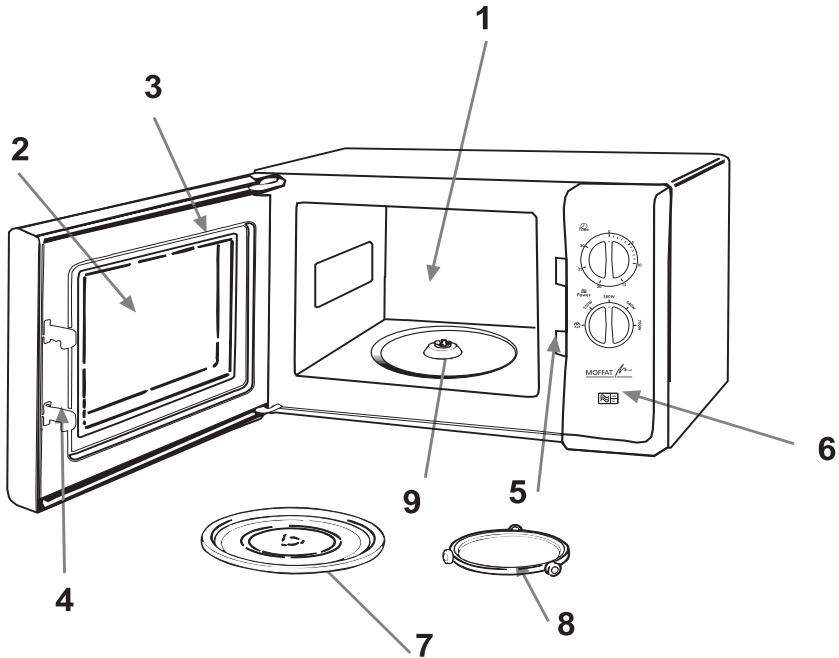

Name and function of parts

1. Cooking compartment. Wipe the compartment clean after using the oven.
2. Viewing window. Food can be checked while the microwave oven is in operation.
3. Oven door. The door must always be firmly closed while cooking.
4. Latch hook.
5. Safety interlock system.
6. Control panel.
7. Turntable. Made of special heat-resistant glass. Food in a suitable container is placed on this tray for cooking. Do not use the oven without the turntable.
8. Turntable support. Place the support on the floor of the cooking chamber to support the turntable.
9. Drive shaft for turntable.

Turntable Installation

1. Place the turntable support on the cavity Bottom.
2. Place the turntable on top of the turntable support as shown in the diagram. Make sure that turntable hub is securely locked in the turntable shaft. **Never place the turntable upside down.**
 - Both turntable and turntable support must always be used during cooking.
 - All food and containers of food are always placed on this turntable for cooking.
 - This turntable rotates clockwise and anticlockwise; this is normal.

Turntable

Roller rest

Turntable Shaft

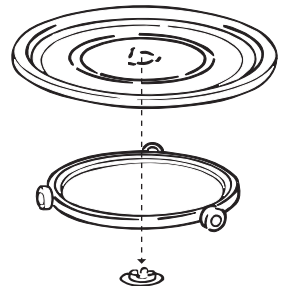

CONTROL PANEL

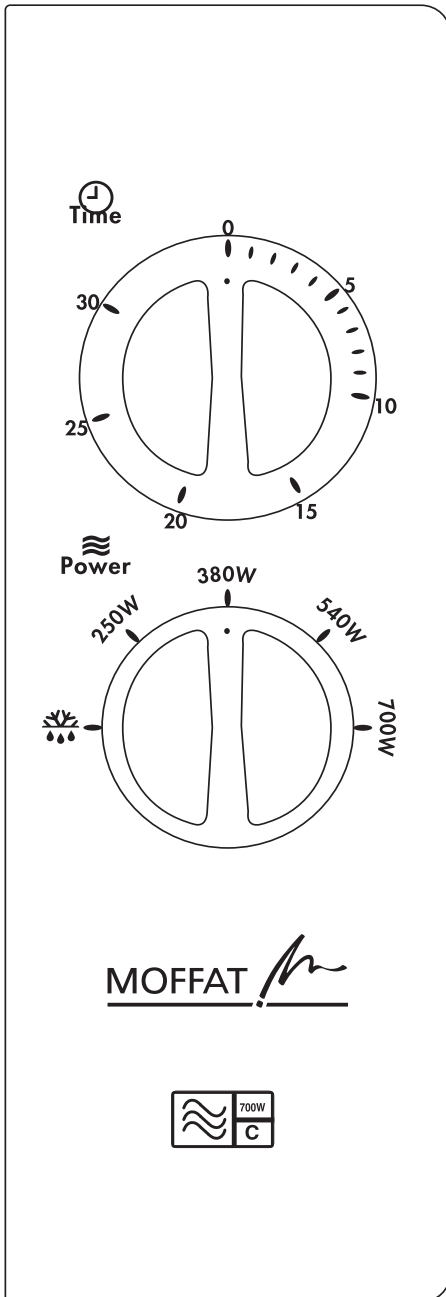

1. Power Selector

Adjust this knob to select the correct power level for your food.

2. Timer

Set for desired cooking time. Cooking will start. All clockwork timers will operate more accurately if wound past the desired time first, and then back.

3. MAFF RATING

Explanation of the heating category label for microwave ovens and small packs of food (up to 500g / 1 lb, typical of ready meals for 1 or 2 people) as agreed by MAFF (the Ministry of Agriculture Fisheries and Food) in conjunction with food and Microwave Oven manufacturers.



Power Rating in Watts.

Heating Category.

Microwave Symbol

- Always follow food manufacturers instructions when cooking ready meals.
- Always ensure that food is piping hot before serving.

N.B. The higher the power output and heating category of the microwave oven, the less heating time is required.

MICROWAVE COOKING

1. Open the door, place the food on the turntable.
Close the door.
2. Set the Power Selector to the desired power level.(See table below.)
3. Set the Timer to the desired time.

The oven begins cooking.

When cooking for less than 2 minutes, turn the timer for a longer period and than return to the desired time.

To turn off the oven during cooking, simply turn the Timer to 0.

Note: After use, be sure to return the Timer to 0, or the oven will continue to operate.

Example: To cook at 540W for 15 minutes

1. Turn the power selector to 540 W.
 2. Turn the timer to 15
 3. The Oven will automatically start cooking for 15 minutes at 540W
-

Microwave Power setting Guide

Power Setting		Suggested use
120W		Defrost ; Thawing frozen foods.
250W	40%	Simmer ; Completing the cooking cycle of some pot roasts. Casseroles and stews. Baked custards or cheesecakes.
380W	60%	Medium ; Faster defrosting and reheating for casseroles and stews. Baking cakes and sponge puddings
540W	80%	Reheat ; Reheating pre-cooked foods. Roasting joints of meat and poultry.
700W(HIW)	100%	Max Power ; Boiling or reheating liquids. Cooking vegetables. Preheating a browning dish.

Defrosting instructions using 120W

Some foods such as bread and fruit, can successfully be thawed manually by using the power setting.

FOOD	PREPARATION	(150W)	STANDING TIME
Bread			
Small loaf	Place on microwave-proof rack or kitchen paper. Turn over halfway through defrosting time.	8–10 min.	10–15 min.
Sliced large loaf	Place on microwave-proof rack or kitchen paper. Turn over halfway through defrosting time.	10–13 min.	10 min
2 slices	Place on kitchen paper.	45–60 sec.	5 min.
1 bread roll	Place on kitchen paper.	45–60 sec.	5 min.
2 bread rolls	Place on kitchen paper.	1–1½ min.	5 min.
Cakes and Pastry			
Gateau 450g/1 lb	Remove from packaging, place on plate.	9–11 min.	15–30 min.
Cheesecake 450g/1 lb	Remove from packaging, place on plate.	9–11 min.	15–30 min.
Pie (cooked) 450g/1 lb	Remove from packaging, place on plate.	7–9 min.	15–30 min.
Pastry 450g/1 lb	Remove from packaging, place on plate.	7–9 min.	15–30 min.
Butter			
250g/8.8 oz (1 packet)	If foil wrapped, remove from wrapper and place on a plate	3–4 min.	5–10 min.
Fruit			
225g/8 oz Soft berry fruits	Place in a single layer in a shallow dish.	5–6 min.	5–10 min.
450g/1 lb Soft berry fruits	Place in a single layer in a shallow dish.	7–8 min.	5–10 min.
Plated meal			
400g/14 oz	Cover with a plate or non P.V.C. cling film. To reheat, microwave on 100% (700W) for 3–4 minutes.	7–8 min	5–10 min.
Vegetables			
	It is not necessary to defrost vegetables before cooking. All vegetables can be thawed and cooked on 100% (700W)		

Microwave Hints

- Always keep the oven clean – avoid spill-overs and do not forget to clean under the glass tray and the inside of the door.
- Preferably use round or oval casseroles with a lid when cooking in your microwave oven.
- Do not use metal or metal decorated casseroles. Certain plastic materials can melt and be warped by hot food.
- Cover the food when cooking. Use a glass lid, a plate or grease proof paper.
- Pastry, bread and the like can be defrosted directly in a bread basket or on a paper towel.
- If frozen food is heated in its packaging, the packaging should be opened. Packaging containing metal or metal decoration must not be used unless specifically recommended for use in the microwave. Remove metal clips and wire ties.
- Smaller pieces of aluminium foil can be used to cover parts that easily over cook such as chicken legs.
- Food with peel or skin should be pierced with a fork – e.g. potatoes and sausages. Do not boil eggs in the microwave oven as they can explode.
- Put large, thick pieces close to the edge of the casserole and try to cut the food in to even sized pieces. Always place the food in the centre of the oven.
- The food will be evenly cooked if you stir or turn it a few times.
- Always set a shorter cooking time than indicated in your recipe to avoid over cooking. The larger the amount of food the longer it takes.
- Use little or no water for vegetables.
- Use less salt and spices than for 'normal' cooking.
- Season afterwards.
- Allow a few minutes 'standing' time after the oven has switched off to ensure complete and even cooking results.
- Always ensure food is piping hot throughout before serving.
- Use pot holders or gloves when taking dishes and food from the oven.

Microwave Tips

- **Softening Honey**
If you have a jar of honey which has crystallised, remove lid and place the jar in the oven, microwave on medium power for 2 minutes.
- **Melting Chocolate**
Break 100g of chocolate into squares, place in a bowl and heat on high power for 1-2 minutes and stir well.
- **Softening or Melting Butter**
Melting takes a few seconds on high power. Softening is best done more gently on low power.
- **Freshen or Warm Bread**
Use medium power for few seconds.
- **Peeling Garlic easily**
Heat 3 or 4 cloves of garlic on high power for 15 seconds. Squeeze at one end until the clove pops out.
- **Fruit Juice**
Citrus fruits will yield more juice if they are heated on high power for 15 seconds before squeezing.
- **Cooking Porridge**
Porridge is easily cooked in the serving dish with no sticky pan to wash. Follow food manufacturers' recommendations.

Care and cleaning

The oven must always be clean. Residue of food from spillovers or splatters will attract microwave energy causing it to burn on. This could reduce the efficiency of the oven and may cause bad odours. Do not attempt to tamper with or make any adjustments or repairs to any part of the oven. Repairs should only be done by a qualified service technician.

Be sure the oven is disconnected from the electricity supply before cleaning.

Cleaning the accessories (turntable and support)

Clean them with mild detergent after removing them from the cavity. The turntable support should be carefully handled.

CAUTION: The inside of the oven and turntable get very hot, so do not touch them immediately after use.

Cleaning the interior

Always keep the inside of the oven clean. Wipe up spill-overs and food splatters immediately. Deposits that are allowed to remain on the oven walls, door seal and door surface will absorb microwave energy, reduce the efficiency of the oven, and possibly damage the oven interior. Use mild, liquid detergent, warm water and a soft, clean cloth to remove deposits.

NEVER USE ABRASIVE CLEANERS, COMMERCIAL OVEN CLEANERS OR STEEL WOOL PADS ON ANY PART OF THE MICROWAVE OVEN.

To loosen difficult deposits, boil a cup of water in the microwave oven for 2 or 3 minutes.

NEVER USE A KNIFE OR ANY UTENSIL TO REMOVE DEPOSITS FROM OVEN SURFACES.

To remove odours from the oven interior, boil a cup of water plus 2 tablespoons of lemon juice for 5 minutes.

Cleaning the exterior

Open the oven door when cleaning the control panel. This will prevent the oven from being turned on accidentally. You should clean outside surfaces of the oven with mild liquid detergent and water followed by a wiping with clear water to remove any excess detergent. Dry with a soft cloth.

Spray-on window cleaners or all purpose spray-on kitchen cleaners can also be used. Never use abrasive cleaners, scouring pads or harsh chemicals on outside surfaces of your oven. To prevent damage to the working parts, do not allow water to seep into ventilation openings.

After Sales Service

Thank you for purchasing this Moffat microwave oven.

We are sure that this product will provide many years of trouble free service to you, however, should you experience any faults with this appliance please contact your retailer for help and advice.

 **From the Electrolux Group.** *The world's No.1 choice.*

The Electrolux Group is the world's largest producer of powered appliances for kitchen, cleaning and outdoor use. More than 55 million Electrolux Group products (such as refrigerators, cookers, washing machines, vacuum cleaners, chain saws and lawn mowers) are sold each year to a value of approx. USD 14 billion in more than 150 countries around the world.

MOFFAT 

