

PROJECT	QUANTITY	ITEM NO
---------	----------	---------

# Hot express case

MODEL **HEC-103**  
**HEC-104**



Hot express case, model HEC-104 with three angled shelves and lower deck.

## General Information

Henny Penny hot express cases are designed to hold and display hot packaged fresh-food items in high-traffic areas for self-serve, impulse sales. The unit's upright orientation and deep shelf design offers high capacity from minimal floor space. HEC models function as aisle end-caps or wall units, providing grab-n-go service from anywhere in store.

High visibility and convenient service access lets operators show off a wide range of popular hot food items while keeping product fresh and appetizing longer.

Individually heated shelves help keep product at ideal temperatures for a fresher, more appetizing hot food display.

The dramatic curved look draws attention to case while providing

maximum product visibility and bright, even lighting throughout cabinet. A carefully designed opaque section of the side glass finishes off the design and blocks shelf attachments from view.

The HEC models are also designed for improved ergonomics, with angled shelves and a higher bottom deck permit easier access. Bumper strip and front mounted, hidden-panel controls are standard.

The HEC comes in three-foot and four-foot lengths, with choice of three or four shelves plus bottom deck. Units are built from high quality materials for long-lasting attractiveness and operation.

## Standard Features

- Upright design saves space and offers merchandising opportunities throughout the store.
- High-efficiency heating elements built into each shelf warm containers from below to help maintain ideal product temperatures.
- Temperature for each shelf can be controlled independently.
- Sleek stainless steel cabinet with stylish tempered glass sidewalls.
- Deep 20 in. (508 mm) shelves hold more product, require less restocking.
- Clear side glass and angled shelves provide optimal product visibility.
- Shatter-resistant fluorescent lights on each level and mirrored stainless steel back wall for bright, uniform lighting.
- Bottom deck set higher for better ergonomics.
- Bumper strip.
- Optional shelf label holders.
- All interior and exterior surfaces are scratch resistant, sanitary and easy to clean.
- Temperature control hidden behind pull-away front panel.
- Front service access.

## Configuration

Please select:

- Three shelves OR
- Four shelves
- Brushed stainless product stop without label holders OR
- Black product stop with label holders for 1 ¼ in. (31 mm) height
- 3-in. casters, two locking OR
- 6-in leveling legs OR
- No casters, no leveling legs—power cord cannot exit bottom.

<input type="checkbox"/> APPROVED	<input type="checkbox"/> APPROVED AS NOTED	<input type="checkbox"/> RESUBMIT
AUTHORIZED SIGNATURE		DATE



Henny Penny Corporation  
PO Box 60 Eaton OH 45320 USA  
+1 937 456.8400 800 417.8417  
+1 937 456.8434 Fax 800 417.8434 Fax  
[www.hennypenny.com](http://www.hennypenny.com)

# Hot express case

MODEL **HEC-103**  
**HEC-104**

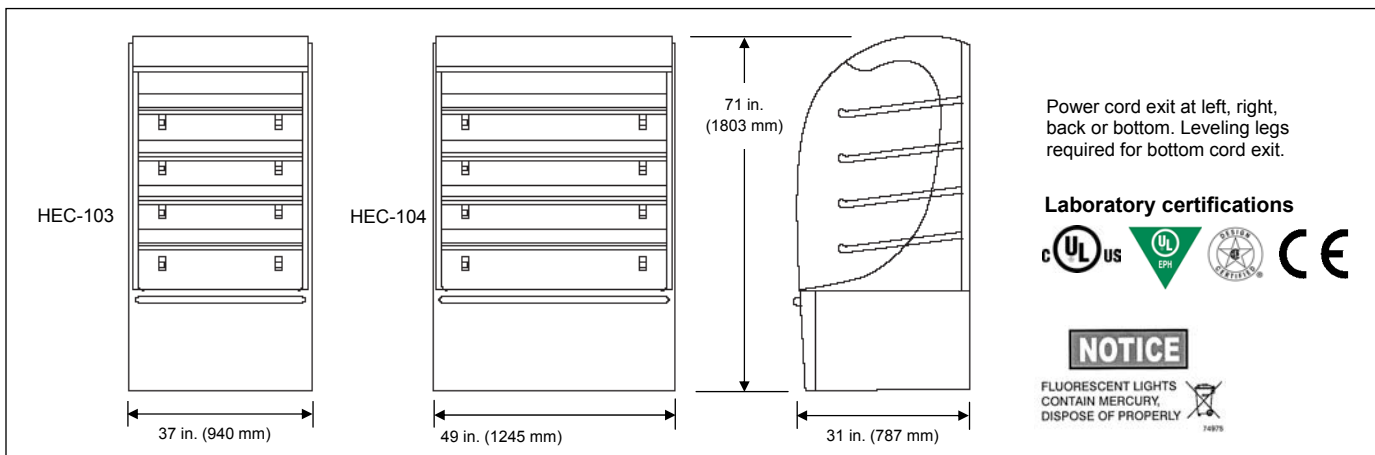

## Dimensions

	HEC-103	HEC-104
Length	37 in. (940 mm)	49 in. (1245 mm)
Depth	31 in. (787 mm)	31 in. (787 mm)
Height	71 in. (1803 mm)	71 in. (1803 mm)

## Required clearances:

Back/side: 4 in. (102 mm) for power cord exit. Legs required for bottom power cord exit.

## Crated dimensions

	HEC-103	HEC-104
Length	45 in. (1143 mm)	56 ¼ in. (1428 mm)
Depth	41 ¼ in. (1048 mm)	41 ¼ in. (1048 mm)
Height	81 ½ in. (2070 mm)	81 ½ in. (2070 mm)
Volume	87.5 cu. ft. (2.45m <sup>3</sup> )	109.5 cu. ft. (3.06 m <sup>3</sup> )

**Net weight:** N/A

## Crated weight

	HEC-103	HEC-104
3-shelf	571 lbs. (259 kg)	705 lbs. (320 kg)
4-shelf	597 lbs. (271 kg)	730 lbs. (331 kg)

## Lighting:

	HEC-103	HEC-104
3-shelf	(4) 550 mm tubes	(4) 850 mm tubes
4-shelf	(5) 550 mm tubes	(5) 850 mm tubes

## Bidding Specifications

- Provide Henny Penny upright hot express case, model HEC-103 three-foot length or HEC-104, four-foot length, for displaying pre-packaged hot foods for immediate self-serve sale.
- All units feature stainless steel and tempered glass construction. Front and top panels are of brushed stainless finish for attractiveness and easy cleaning.
- Units shall be equipped with three or four angled shelves.
- Heating shall be provided through

individually controlled electric elements in each shelf and bottom deck.

- Back wall shall be mirrored, perforated stainless steel for enhanced display.
- Lighting fixtures accept shatter resistant

fluorescent tubes.

- Power cord and plug are included with 208V and 240V units for North American destinations.

## Capacity

	HEC-103	HEC-104
Per shelf/deck	20 x 33 in. (508 x 838 mm) or 8 chicken domes	20 x 45 in. (508 x 1143 mm) or 12 chicken domes
Total 3-shelf + deck	18.3 sq. ft. (1.7 m <sup>2</sup> ) or 32 chicken domes	25.0 sq. ft. (2.3 m <sup>2</sup> ) or 48 chicken domes
Total 4-shelf + deck	22.9 sq. ft. (2.1 m <sup>2</sup> ) or 40 chicken domes	31.2 sq. ft. (2.9 m <sup>2</sup> ) or 60 chicken domes

## Electrical

		HEC-103				3-shelf unit		4-shelf unit			
Volts	Phase	Cycle/Hz	Watts	Amps	Watts	Amps	Wire	Plug			
208	1	50-60	2380	11.4	2802	13.5	2+G	 NEMA 6-20P			
220-240	1	50-60	2380	9.9	2802	11.7	2+G				
230	1	50-60	2191	9.5	2580	11.2	1NG				
240	1	50-60	2380	9.9	2802	11.7	2+G				
208	3	50-60	2380	8.0	2802	8.3	3+G	 NEMA 15-30P			
220-240	3	50-60	2380	6.9	2802	7.2	3+G				
240	3	50-60	2380	6.9	2802	7.2	3+G				
380-415	3	50-60	2380	4.6	2802	4.6	3NG				
400	3	50-60	2191	4.4	2580	4.4	3NG				
		HEC-104				3-shelf unit		4-shelf unit			
208	1	50-60	3366	16.2	3931	18.9	2+G	 NEMA 6-20P			
220-240	1	50-60	3366	14.0	3931	16.4	2+G				
240	1	50-60	3366	14.0	3931	16.4	2+G	 NEMA 6-30P			
208	3	50-60	3366	11.8	3931	11.9	3+G				
220-240	3	50-60	3366	10.2	3931	10.3	3+G				
240	3	50-60	3366	10.2	3931	10.3	3+G				
380-415	3	50-60	3366	6.9	3931	6.9	3NG				
400	3	50-60	3100	6.6	3621	6.6	3NG	 NEMA 15-30P			

Continuing product improvement may subject specifications to change without notice.

**HENNY PENNY**  
Global Foodservice Solutions

[www.hennypenny.com](http://www.hennypenny.com)