

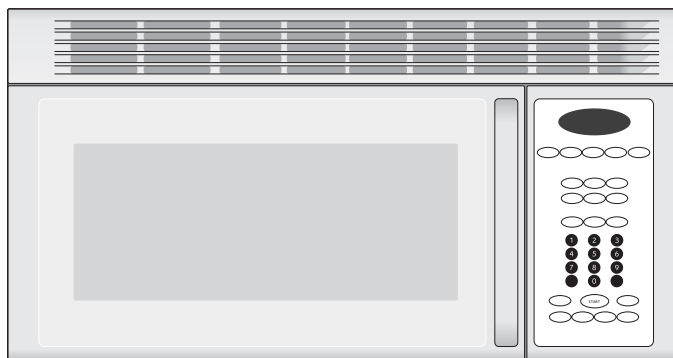

FRIGIDAIRE
Gallery



PRODUCT NO.	BASE MODEL NO.	COLOR	MARKET
FMT144G1B1	FMT144GB	BLACK	USA
FMT144G1W1	FMB144GW	WHITE	USA
FMT148G1B1	FMT148GB	BLACK	USA
FMT148G1W1	FMT148GW	WHITE	USA
FMT148G1T1	FMT148GT	ALMOND	USA
FMT148GPB1	FMT148GP	STAINLESS	USA
FMT144G1B2	FMT144GB	BLACK	USA
FMT144G1W2	FMB144GW	WHITE	USA
FMT148G1B2	FMT148GB	BLACK	USA
FMT148G1W2	FMT148GW	WHITE	USA
FMT148G1T2	FMT148GT	ALMOND	USA
FMT148GPB2	FMT148GP	STAINLESS	USA

WIRING DIAGRAM # - N/A
OWNER'S GUIDE# - 5304409000 & 5304409002
INSTALLATION INSTRUCTIONS # - 5304409004



P. O. Box 212378
Augusta, Georgia 30917

**NOTE: This publication supersedes
Publication No: 5995315578.**

Publication No.

5995338778

EN/SERVICE/JBL
369

MICROWAVE

Model Nos.

- FMT144G1B1
- FMT144G1W1
- FMT148G1B1
- FMT148G1W1
- FMT148G1T1
- FMT148GPB1
- FMT144G1B2
- FMT144G1W2
- FMT148G1B2
- FMT148G1W2
- FMT148G1T2
- FMT148GPB2

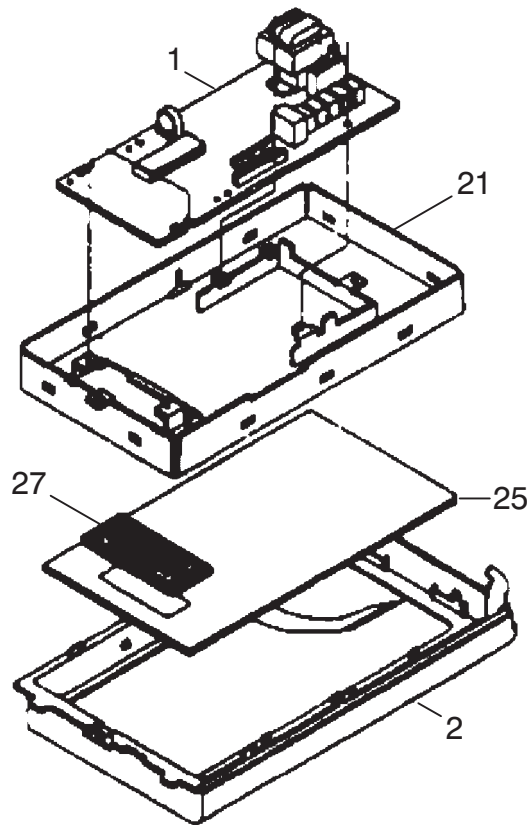

P28C1490 rev 06/00

CONTROL PANEL

A = FMT144GB (FMT144G1B1 & FMT144G1B2)
B = FMT144GW (FMT144G1W1 & FMT144G1W2)
C = FMT148GB (FMT148G1B1 & FMT148G1B2)
D = FMT148GW (FMT148G1W1 & FMT148G1W2)
E = FMT148GT (FMT148G1T1 & FMT148G1T2)
F = FMT148GP (FMT148GPB1 & FMT148GPB2)

POS NO.	PART NO.		DESCRIPTION
1#	5304408302	A B - - -	Control Board, PCB
1#	5304408501	- - C D E F	Control Board, PCB
2	5304408507	A - - - -	Control Panel-Black
2	5304408508	- B - - - -	Control Panel-White
2	5304408509	- - C - - F	Control Panel-Black
2	5304408511	- - - D - -	Control Panel-White
2	5304408510	- - - - E -	Control Panel-Almond
21	5304408514	A B - - -	Bracket, Control Panel
21	5304408515	- - C D E -	Bracket, Control Panel
21	5304408516	- - - - - F	Bracket, Control Panel
25#	5304408503	A - - - -	Membrane, Touchpad
25#	5304408303	- B - - - -	Membrane, Touchpad
25#	5304408502	- - C - - -	Membrane, Touchpad
25#	5304408504	- - - D - -	Membrane, Touchpad
25#	5304408505	- - - - E -	Membrane, Touchpad
25#	5304408506	- - - - - F	Membrane, Touchpad
27	5304408512	A B - - -	Lens
27	5304408513	- - C D E F	Lens

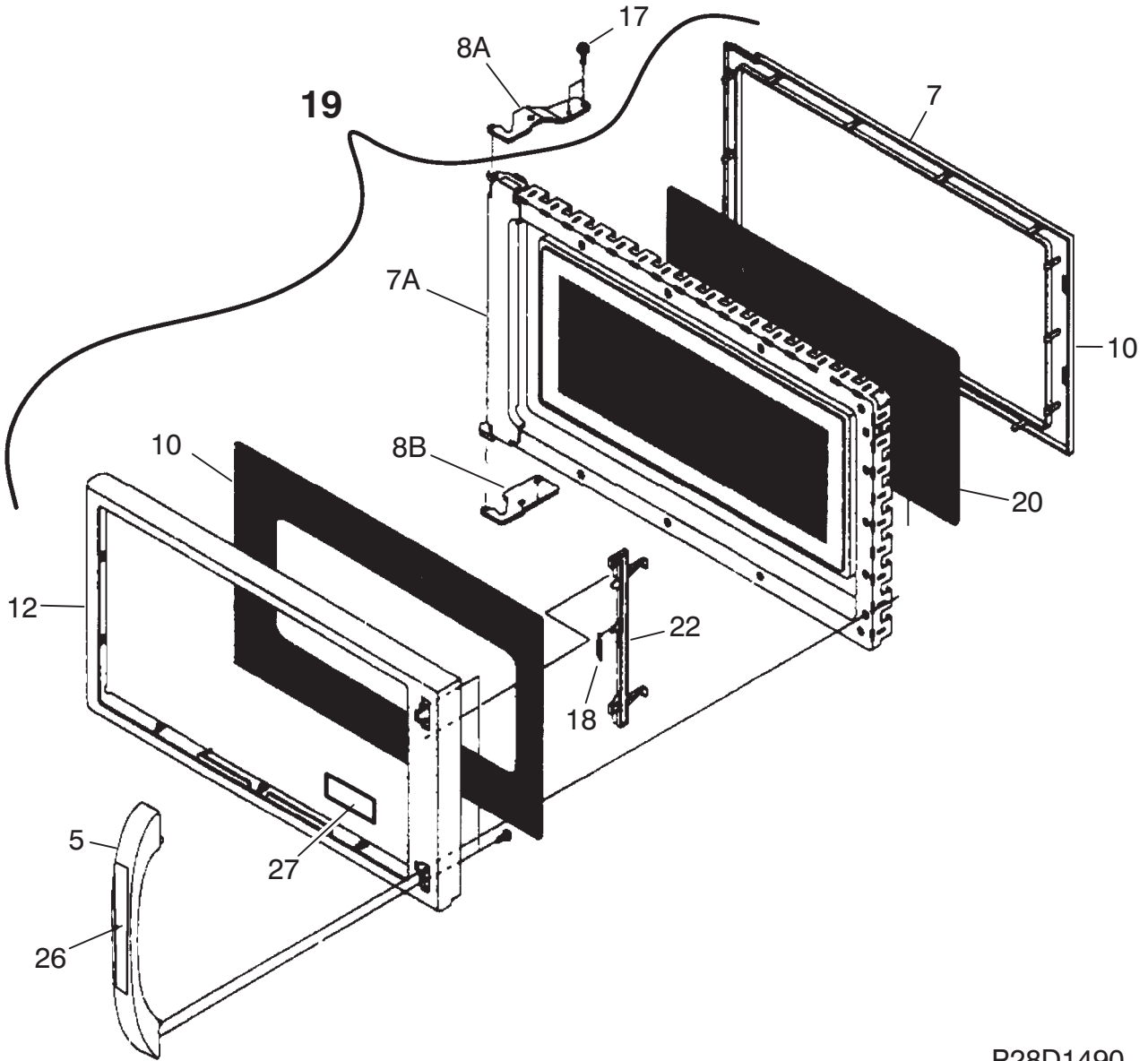

P28D1490

DOOR

A = FMT144GB (FMT144G1B1 & FMT144G1B2)
B = FMT144GW (FMT144G1W1 & FMT144G1W2)
C = FMT148GB (FMT148G1B1 & FMT148G1B2)
D = FMT148GW (FMT148G1W1 & FMT148G1W2)
E = FMT148GT (FMT148G1T1 & FMT148G1T2)
F = FMT148GP (FMT148GPB1 & FMT148GPB2)

POS NO.	PART NO.	DESCRIPTION
5	5304408523	A - - - - Door Handle Assembly-Black
5	5304408524	- B - - - Door Handle Assembly-White
5	5304408525	- - C - - Door Handle Assembly-Black
5	5304408527	- - - D - - Door Handle Assembly-White
5	5304408526	- - - - E - Door Handle Assembly-Almond
5	5304408528	- - - - F Door Handle Assembly (for SS model)
7	5304408575	A - C - - F Door-Choke, Inner Frame (Black & SS models)
7	5304408576	- B - D - - Door-Choke, Inner Frame (White models)
7	5304408577	- - - E - Door-Choke, Inner Frame (Almond model)
7A	5304409132	A - C - - F Door-Liner (Black & SS models)
7A	5304409134	- B - D - - Door-Liner (White models)
7A	5304409133	- - - E - Door-Liner (Almond model)
8A	5304408578	A B C D E F Plate-Hinge, Upper
8B	5304408579	A B C D E F Plate-Hinge, Lower
10	5304408529	A B - - - Cover-Door, Outer (no color)
10	5304408530	- - C - - Cover-Door, Outer, Black
10	5304408532	- - - D - Cover-Door, Outer, White
10	5304408531	- - - - E - Cover-Door, Outer, Almond
10	5304408533	- - - - F Cover-Door, Outer (no color)
12	5304408534	A - - - - Panel-Door, Outer, Black
12	5304408535	- B - - - Panel-Door, Outer, White
12	5304408536	- - C - - F Panel-Door, Outer, Black
12	5304408538	- - - D - - Panel-Door, Outer, White
12	5304408537	- - - - E - Panel-Door, Outer, Almond
17	5304408958	A B C D E F Screw-Flange
18	5304409135	A B C D E F Spring-Door Latch
19	5304408517	A - - - - Door-Complete, Black
19	5304408518	- B - - - Door-Complete, White
19	5304408519	- - C - - - Door-Complete, Black
19	5304408521	- - - D - - Door-Complete, White
19	5304408520	- - - - E - Door-Complete, Almond
19	5304408522	- - - - F Door-Complete (for Stainless model)
20	5304409136	A B C D E F Seal-Film
22	5304409137	A - C - - F Latch-Door
22	5304409138	- B - D E - Latch-Door
26	5304409140	- - - - F Cap-Handle (for Stainless model))
27	5304409139	- - - - F Nameplate-Brand (for Stainless model)

= Funtional part
 * = Non-illustrated part

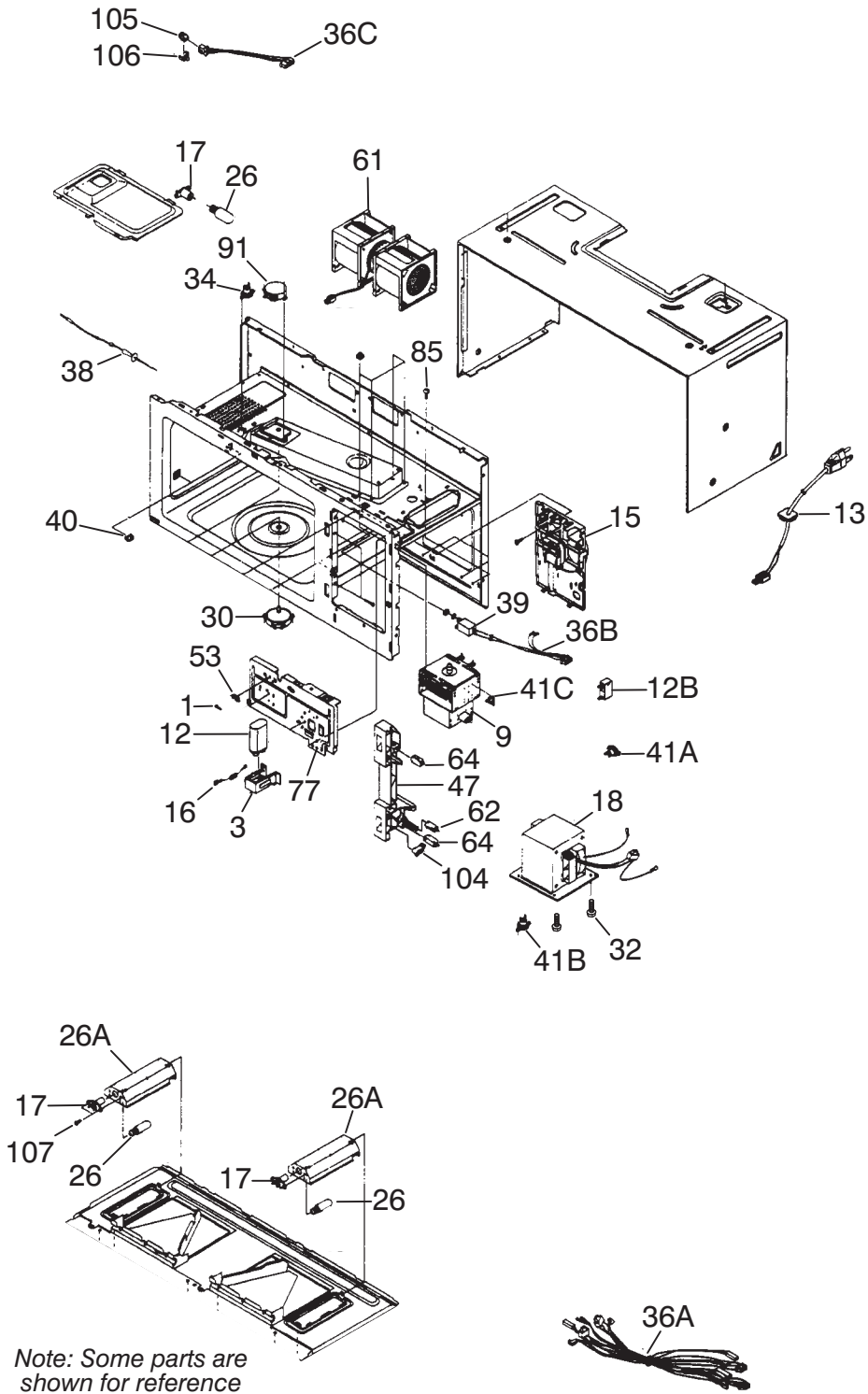

Note: Some parts are shown for reference only.

P28F1490 rev 06/00

FUNCTIONAL

A = FMT144GB (FMT144G1B1 & FMT144G1B2)
B = FMT144GW (FMT144G1W1 & FMT144G1W2)
C = FMT148GB (FMT148G1B1 & FMT148G1B2)
D = FMT148GW (FMT148G1W1 & FMT148G1W2)
E = FMT148GT (FMT148G1T1 & FMT148G1T2)
F = FMT148GP (FMT148GPB1 & FMT148GPB2)

POS NO.	PART NO.		DESCRIPTION
1#	5304408939	A B C D E F	Fuse
3	5304408946	A B C D E F	Retainer-Capacitor
9#	5304408930	A B C D E F	Magnetron
12#	5304408931	A B C D E F	Capacitor
12B#	5304408941	A B C D E F	Capicitor-Motor
13#	5304408947	A B C D E F	Cord-Power, Electric
15#	5304408942	A B C D E F	Motor-Fan Assembly
16#	5304408932	A B C D E F	Diode-High Voltage
17#	5304408948	A B C D E F	Socket-Lamp
18#	5304408933	A B C D E F	Transformer-H.V.
26#	5304408949	A B C D E F	Lamp
26A	5304408954	A B C D E F	Bracket-Lamp
30#	5304408980	A B C D E F	Motor-Turntable
32	5304408958	A B C D E F	Screw-Transformer Mounting
34#	5304408940	A B C D E F	Fuse-Thermal Cutout, 120/0
36A#	5304408951	A B C D E F	Harness-Wire, A
36B#	5304408952	A B C D E F	Harness-Wire, B
36C#	5304408956	- - C D E F	Harness-Wire, S
38#	5304408955	- - C D E F	Probe
39#	5304408959	- - C D E F	Probe-Receptacle
40	5304408965	- - C D E F	Rack Holder
41A#	5304408934	A B C D E F	Switch-Thermal Cutout, 40/70
41B#	5304408935	A B C D E F	Switch-Thermal Cutout, 120/0
41C#	5304408936	A B C D E F	Switch-Thermal Cutout, 160/60
47	5304408960	A B C D E F	Latch-Body
53	5304408999	A B C D E F	Fuse-Holder
61	5304408943	A B C D E F	Motor Assembly-Ventilation
62#	5304408937	A B C D E F	Switch-Monitor
64#	5304408938	A B C D E F	Switch-Secondary
77	5304408961	A B C D E F	Bracket-Air Guide
85	5304408962	A B C D E F	Nut-Magnetron Mounting
91#	5304408944	A B C D E F	Motor-Stirrer
104	5304408963	A B C D E F	Lever-Switch, Lower
105#	5304408945	- - C D E F	Sensor-Gas
106	5304408957	- - C D E F	Holder-Gas Sensor
107	5304408964	A B C D E F	Scew-Special

= Funtional part
 * = Non-illustrated part

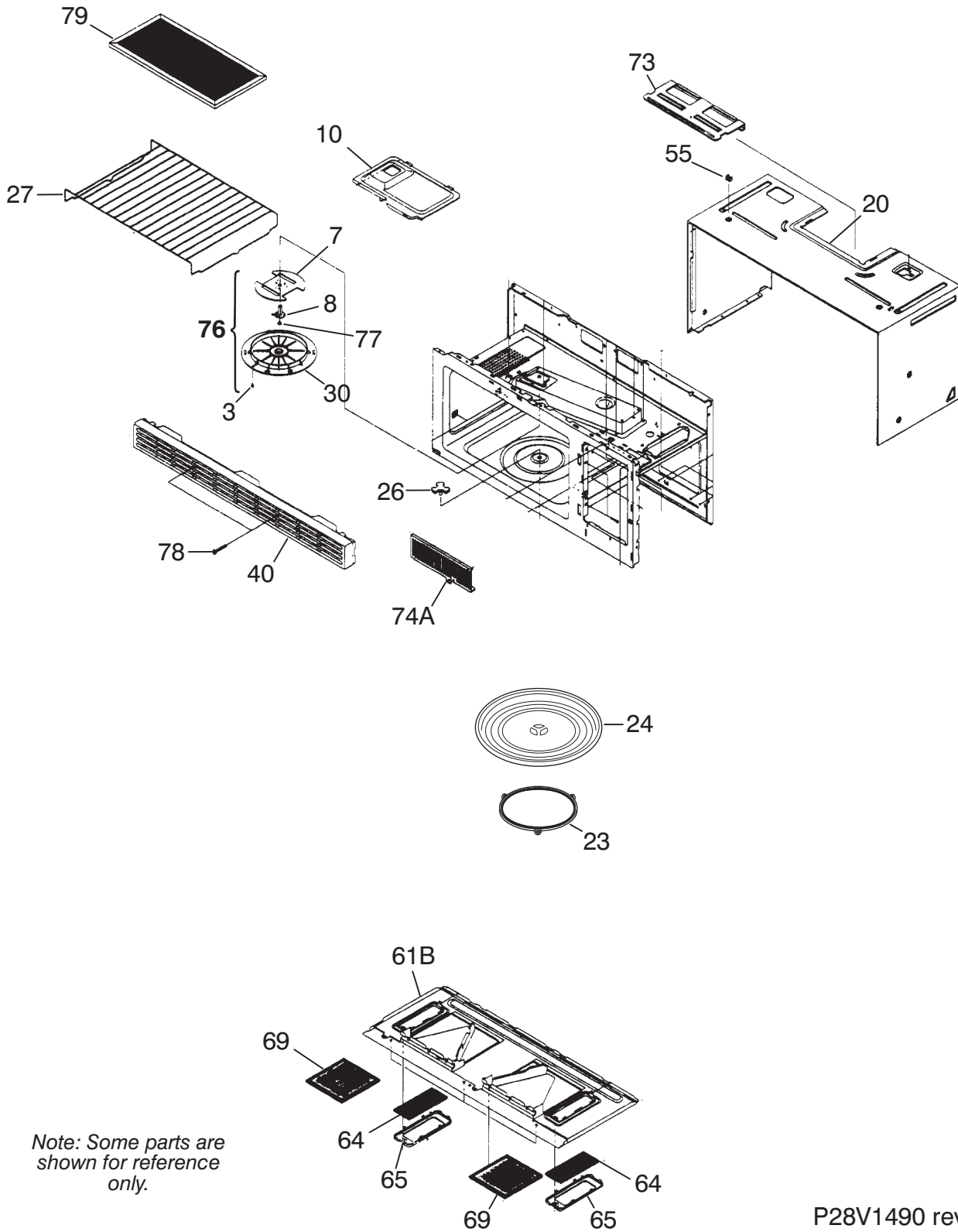

Note: Some parts are shown for reference only.

BODY

A = FMT144GB (FMT144G1B1 & FMT144G1B2)
B = FMT144GW (FMT144G1W1 & FMT144G1W2)
C = FMT148GB (FMT148G1B1 & FMT148G1B2)
D = FMT148GW (FMT148G1W1 & FMT148G1W2)
E = FMT148GT (FMT148G1T1 & FMT148G1T2)
F = FMT148GP (FMT148GPB1 & FMT148GPB2)

POS NO.	PART NO.		DESCRIPTION
3	5304408979	A B C D E F	Rivet - Stirrer Cover
7	5304408950	A B C D E F	Fan - Stirrer
8	5304408981	A B C D E F	Collar - Stirrer
10	5304408982	A B C D E F	Cover - Light/Upper Duct
20	5304408975	A - C - - F	Wrapper - Outer, Black
20	5304408976	- B - D - -	Wrapper - Outer, White
20	5304412004	- - - - E -	Wrapper - Outer, Almond
23	5304408983	A B C D E F	Support - Roller Assembly (LOT 01 ONLY)*
23	5304417414	A B C D E F	Support - Roller Assembly (LOT 02 ONLY)*
24	5304408984	A B C D E F	Tray - Turntable, Glass
26	5304408985	A B C D E F	Bushing - Turntable Motor Coupler (LOT 01 ONLY)*
26	5304417415	A B C D E F	Bushing - Turntable Motor Coupler (LOT 02 ONLY)*
27	5304408995	- - C D E F	Rack - Microwave Oven
30	5304408986	A B C D E F	Cover - Stirrer
40	5304408966	A - - - - -	Grille - Vent, Black
40	5304408967	- B - - - -	Grille - Vent, White
40	5304408968	- - C - - F	Grille - Vent, Black
40	5304408970	- - - D - -	Grille - Vent, White
40	5304408969	- - - - E -	Grille - Vent, Almond
55	5304408987	A B C D E F	Screw - Nut Holder Assembly (2)
61B	5304408971	A - C - - F	Cover - Base Plate
61B	5304408972	- B - D E -	Cover - Base Plate
64	5304408988	A B C D E F	Glass - Cooktop Lamp (2)
65	5304408973	A - C - - F	Bracket - Cooktop Glass (2)
65	5304408974	- B - D E -	Bracket - Cooktop Glass (2)
69	5304408977	A B C D E F	Filter - Air (2)
73	5304408989	A B C D E F	Plate - Wrapper, Top
74A	5304408990	A B C D E F	Cover - Front
76	5304408991	A B C D E F	Stirrer Assembly (includes item# 3, 7, 8, 30 & 77)
77	5304408992	A B C D E F	Holder - Tip
78	5304408994	A - C - - F	Screw - Grille, Black (2)
78	5304408993	- B - D - -	Screw - Grille, White (2)
78	5304417413	- - - - E -	Screw - Grille, Almond (2)
79	5304408978	- - C D E F	Filter - Charcoal

* NOTE: Matrix does not reflect lot number. Order correct part for proper lot per notation in parts list.

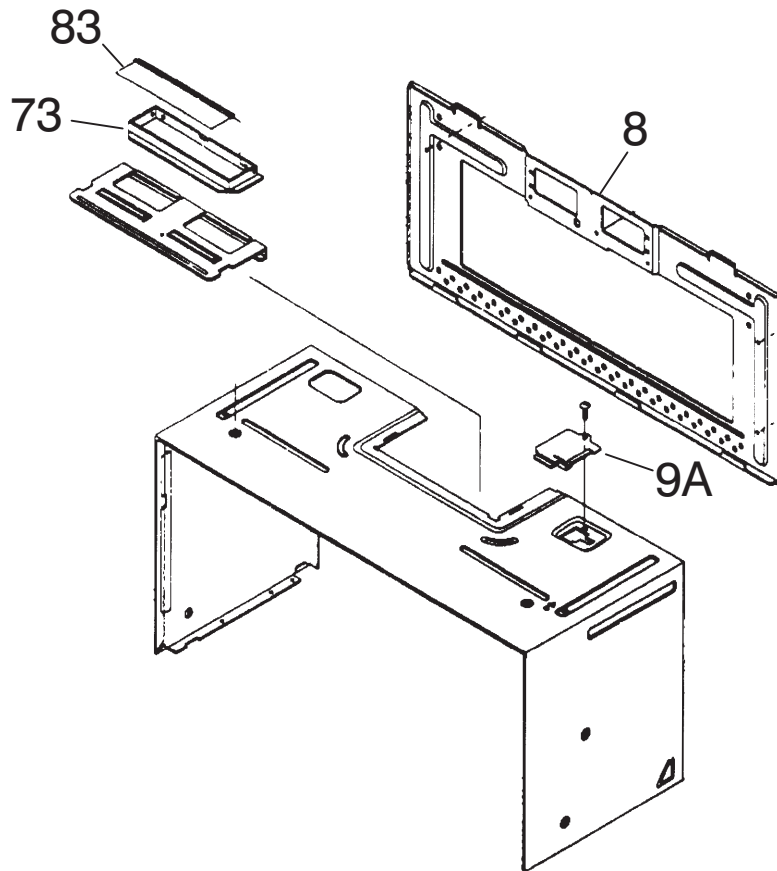

Note: Some parts are shown for reference only. These parts will be listed in other sections

P28I1490

INSTALLATION PARTS

A = FMT144GB (FMT144G1B1 & FMT144G1B2)
B = FMT144GW (FMT144G1W1 & FMT144G1W2)
C = FMT148GB (FMT148G1B1 & FMT148G1B2)
D = FMT148GW (FMT148G1W1 & FMT148G1W2)
E = FMT148GT (FMT148G1T1 & FMT148G1T2)
F = FMT148GP (FMT148GPB1 & FMT148GPB2)

POS NO.	PART NO.		DESCRIPTION
2A	5304408953	A B C D E F	Damper-Exhaust Frame
2B	5304408998	A B C D E F	Damper-Exhaust Cover
8	5304408996	A B C D E F	Plate-Mounting
9A	5304408997	A B C D E F	Bracket-Power Cord
*	5304409000	A B - - -	Use & Care Manual
*	5304409002	- - C D E F	Use & Care Manual
*	5304409003	A B C D E F	Installation Template-Taop Cabinet
*	5304409004	A B C D E F	Installation Instructions
*	5304409005	A B - - -	Mini Manual
*	5304409006	- - C D E F	Mini Manual
*	316003484	A B C D E F	Replacement Parts Catalog
*	JX81A	A B C D E F	Kit-Recirculating Charcoal Filter (for internal venting)
*	5304411140	A B C D E F	Kit-Hardware Mounting, Installation
*	JX40WH		Kit-Filler Panel-White (for 12" high cabinet opening)
*	JX41BL		Kit-Filler Panel-Black (for 12" high cabinet opening)
*	JX46WH		Kit-Filler Panel-White (for 15" high cabinet opening)
*	JX46BL		Kit-Filler Panel-Black (for 15" high cabinet opening)

WARNING

POWER MUST BE DISCONNECTED
BEFORE SERVICING THIS APPLIANCE

COLOR	SYMBOL
GRAY	GR
WHITE	W
BLACK	B
RED	R
BLUE	BL
ORANGE	O
YELLOW	Y
GREEN	G
PINK	P
AZURE	A
VIOLET	V
BROWN	BR

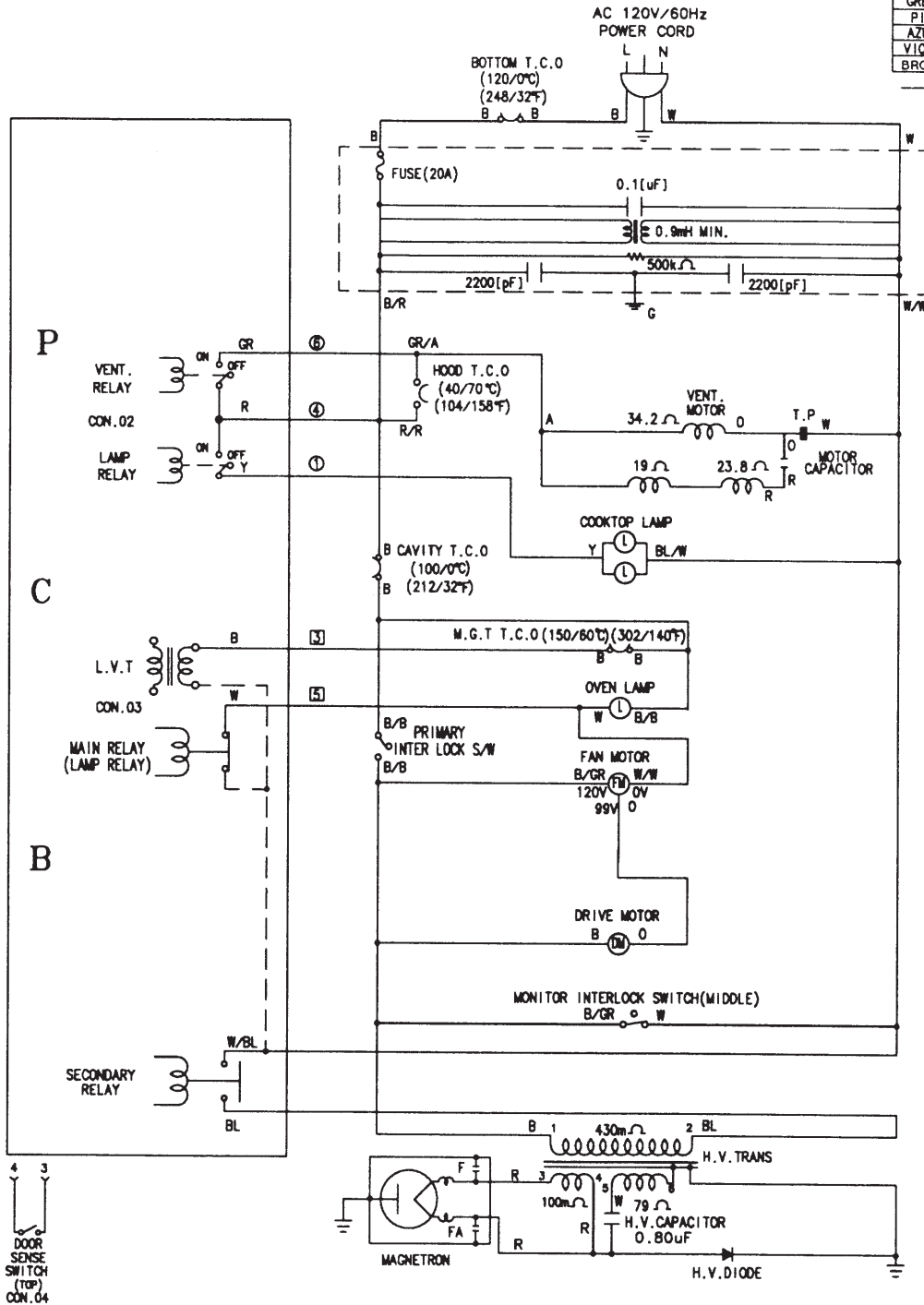

NOTE: DOOR IS OPEN.
PROBE SWITCH IS CLOSED.

WARNING

POWER MUST BE DISCONNECTED
 BEFORE SERVICING THIS APPLIANCE

COLOR	SYMBOL
GRAY	GR
WHITE	W
BLACK	B
RED	R
BLUE	BL
ORANGE	O
YELLOW	Y
GREEN	G
PINK	P
AZURE	A
VIOLET	V
BROWN	BR

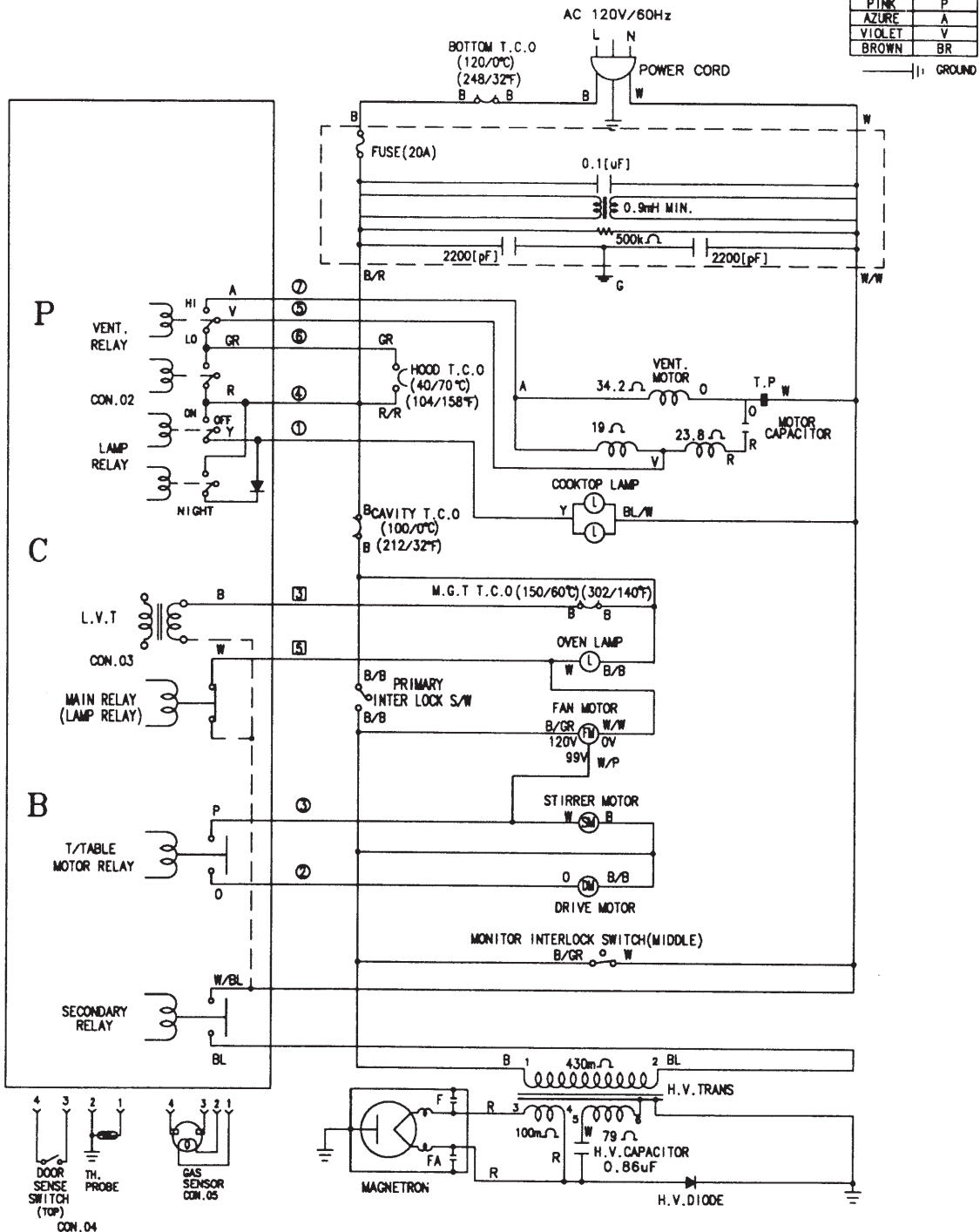

NOTE: DOOR IS OPEN.
 PROBE SWITCH IS CLOSED.