

air-o-steam® Electric Combi Oven 102

ITEM # _____
 MODEL # _____
 PROJECT NAME # _____
 SIS # _____
 AIA # _____



* Base not included

air-o-steam® Electric Combi Oven 102

- | | |
|---------------------|--|
| 267083 (AOS102EAM1) | Electric Combi Oven 102
208 V/3p/60Hz - 69A |
| 267093 (AOS102EAB1) | Electric Combi Oven 102
240 V/3p/60Hz - 60A |

Short Form Specification

Item No. _____

Unit to be Electrolux air-o-steam® Combi Oven AOS102E. The air-o-steam® features three cooking modes – Steam (77 °F-266 °F), Hot convected air (77 °F-572 °F) and Combi-mode (77 °F-482 °F). Each cooking mode operates under lambda-sensor driven air-o-clima: automatic and constant real humidity control. 6-point multi-sensor for core temperature controlled cooking cycles. Pre-programmed Low Temperature Cooking cycle (LTC) and programmable memory (up to 100, 7-step programs available), 20 factory pre-set cooking programs included. Large LED display for both set and actual values of humidity and temperature in cooking chamber during cooking. All 304 stainless-steel construction, seamless hygienic cooking chamber with all rounded corners. Double thermo-glazed door with open frame construction for cool outside door panel. Halogen cooking chamber lighting. IPX-5 (NEMA 4) spray water protection certification. Retractable spray hose included as standard.

air-o-clean, automatic and built-in self-cleaning system.
 EKIS, pc-controlled HACCP monitoring software package available at additional cost.
 Half day chef training included.
 Covered by Electrolux Platinum Star® Service Program two-year parts and one-year labor warranty, installation start-up and performance check-up after one year from installation.



Approval: _____

Main features

- Dry, hot convection cycle (77 °F to 572 °F): ideal for low humidity baking.
- Low temperature steam cycle (77 °F to 211 °F): ideal for sous-vide (vacuum packed) re-thermalization and delicate cooking.
- Steam cycle (212 °F): seafood and vegetables.
- High temperature steam (213 °F to 266 °F).
- Combination cycle (77 °F to 482 °F): combining convected heat and steam to obtain humidity controlled cooking environment, accelerating the cooking process and reducing weight loss.
- Pre-programmed re-thermalization cycles for banqueting applications.
- **air-o-clima:** lambda sensor controlled automatic humidity adjustment of cooking environment (PATENT).
- 6-point multi-sensor core temperature probe.
- Pre-programmed Low Temperature Cooking cycle (LTC): minimizes weight loss, maximizes food quality for large pieces of meat (PATENT).
- Cook&Hold cycle.
- Variable fan speed. Radial fan.
- Reduced power cycle.
- 20 pre-set cooking programs in memory for most popular cooking items.
- 100 program locations in on-board memory, up to 7 cooking steps each.
- **air-o-clean:** built-in and automatic self-cleaning system.
- Electrolux Platinum Star® Service package included:
 - 2-year parts, 1-year labor warranty.
 - Start-up install check.
 - Equipment check-up after 12 month from installation.
 - Half day chef training session.

Construction

- IPX 5 splash water protection certification for easy cleaning.
- All 304 stainless steel construction.
- Seamless hygienic cooking chamber with all rounded corners for easy cleaning.
- Double thermo-glazed door with open frame construction, for cool outside door panel.
- Swing hinged easy-release inner glass on door for easy cleaning.
- Swing hinged front panel for easy service access to main components.
- Integrated spray hose included.

Included Accessories

- 10 304 stainless steel grids PNC 922076

Optional Accessories

- 1 rack cassette (10 racks) PNC 922043
- Open base stand PNC 922063
- Trolley for rack cassette PNC 922042
- Increased pitch rack cassette (8 racks) PNC 922045
- Roll-in rack support PNC 922047
- 51 plate rack PNC 922052
- Thermal blanket for banqueting rack PNC 922048
- Pair of chicken racks (8 chickens per rack) PNC 922036
- Non-stick universal pans PNC 922090-2
- Combi oven grill PNC 922093
- 4 castors (2 with brake) PNC 922057
- Fat filters PNC 922178
- Frying griddle PNC 922215
- Stacking kit 61 on top of 61 or 102 electric PNC 922221
- Pair of frying baskets PNC 922239
- Heat shield for 102 PNC 922252
- Stacking kit 62 on top of 62 or 102 electric PNC 922267

Front View

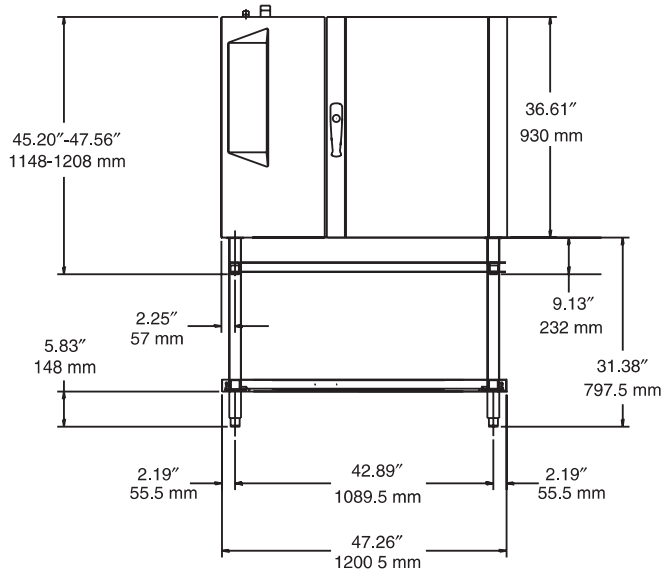

Top View

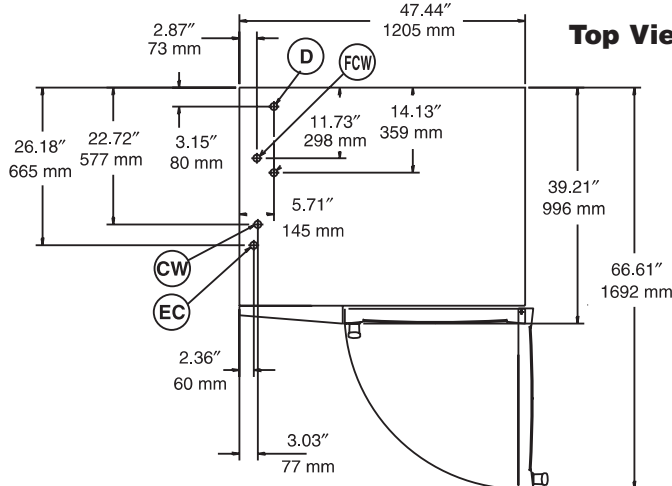

EC = Electrical connection
D = Water drain
CW = Cold Water inlet
FCW = Filtered Cold Water inlet

Side View

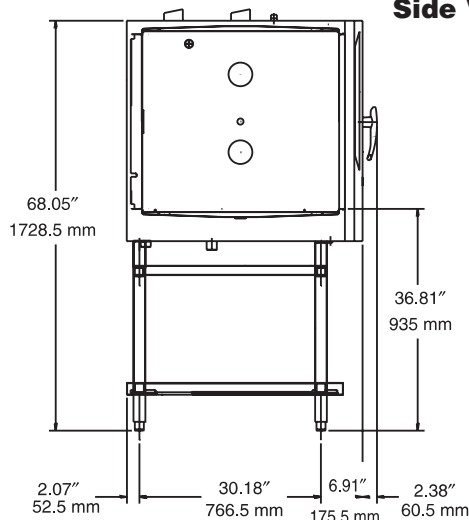

Electric

Supply voltage:

267083 (AOS102EAM1) 208 V/3p/60Hz - 69A

267093 (AOS102EAB1) 240 V/3p/60Hz - 60A

Connected load:

25 kW

Circuit breaker required

Water

Water Consumption (gal./hr.): Min: 4.49 Max: 20.08

Water inlet "CW" - 3/4" connection:

Unfiltered drinking water

Water inlet "FCW" - 3/4" connection:

Total hardness: 5-50 ppm

Pressure: 22-36 psi (150-250 kPa)

Drain "D"

1-1/4" connection

Electrolux recommends the use of treated water, based on testing of specific water conditions.

Please refer to user manual for detailed water quality information.

Installation

Clearance: 2" (5 cm) rear and right hand sides.

Suggested clearance

for service access: 20" (50 cm) left hand side.

Capacity

Sheet pans: 10 - 18" x 26"

Steam pans: 20 - 12" x 20"

Half size sheet pans: 20 - 13" x 18"

GN: 20 - 1/1 containers

10 - 2/1 containers

Max load capacity: 180 lbs. (80 kg)

Key Information

Net weight: 461 lbs. (209 kg)

Shipping weight: 496 lbs. (225 kg)

Shipping width: 50" (1270 mm)

Shipping height: 52-3/8" (1330 mm)

Shipping depth: 44-7/8" (1140 mm)

Shipping Volume: 68.15 cu. ft. (1.93 m³)