

THS2422 / CH2422

SPLIT SYSTEM AIR CONDITIONER

Indoor Unit

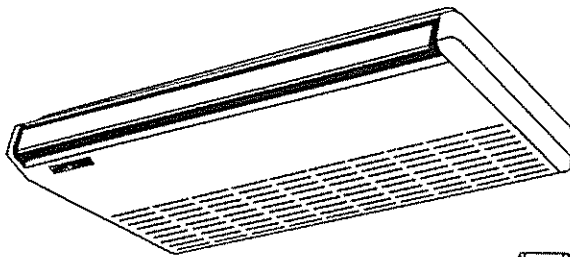

THS2422



Outdoor Unit

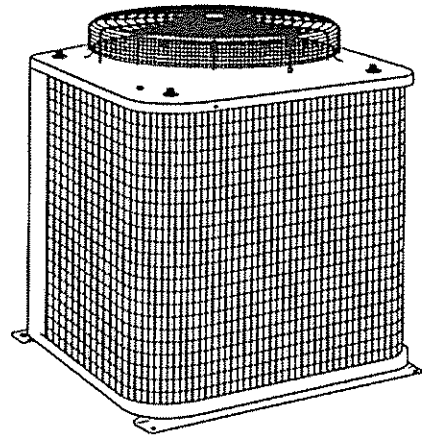

CH2422

SERVICE MANUAL

THS2422 / CH2422

(Basic Information)

IMPORTANT! **Please Read Before Starting**

This air conditioning system meets strict safety and operating standards. As the installer or service person, it is an important part of your job to install or service the system so it operates safely and efficiently.

For safe installation and trouble-free operation, you must:

- Carefully read this instruction booklet before beginning
- Follow each installation or repair step exactly as shown
- Observe all local, state, and national electrical codes
- Pay close attention to all warning and caution notices given in this manual



WARNING:

This symbol refers to a hazard or unsafe practice which can result in severe personal injury or death.



CAUTION:

This symbol refers to a hazard or unsafe practice which can result in personal injury or product or property damage.

If Necessary, Get Help

These instructions are all you need for most installation sites and maintenance conditions. If you require help for a special problem, contact our sales/service outlet or your certified dealer for additional instructions.

In Case of Improper Installation

The manufacturer shall in no way be responsible for improper installation or maintenance service, including failure to follow the instructions in this document.

SPECIAL PRECAUTIONS

When Wiring

ELECTRICAL SHOCK CAN CAUSE SEVERE PERSONAL INJURY OR DEATH. ONLY A QUALIFIED, EXPERIENCED ELECTRICIAN SHOULD ATTEMPT TO WIRE THIS SYSTEM.

- Do not supply power to the unit until all wiring and tubing are completed or reconnected and checked.
- Highly dangerous electrical voltages are used in this system. Carefully refer to the wiring diagram and these instructions when wiring. Improper connections and inadequate grounding can cause **accidental injury or death**.
- **Ground the unit** following local electrical codes.
- Connect all wiring tightly. Loose wiring may cause overheating at connection points and a possible fire hazard.

When Transporting

Be careful when picking up and moving the indoor and outdoor units. Get a partner to help, and bend your knees when lifting to reduce strain on your back. Sharp edges or thin aluminum fins on the air conditioner can cut your fingers.

When Installing...

...In a Ceiling or Wall

Make sure the ceiling/wall is strong enough to hold the unit's weight. It may be necessary to construct a strong wood or metal frame to provide added support.

...In a Room

Properly insulate any tubing run inside a room to prevent "sweating" that can cause dripping and water damage to walls and floors.

...In Moist or Uneven Locations

Use a raised concrete pad or concrete blocks to provide a solid, level foundation for the outdoor unit. This prevents water damage and abnormal vibration.

...In an Area with High Winds

Securely anchor the outdoor unit down with bolts and a metal frame. Provide a suitable air baffle.

...In a Snowy Area (for Heat Pump-type Systems)

Install the outdoor unit on a raised platform that is higher than drifting snow. Provide snow vents.

When Connecting Refrigerant Tubing

- Keep all tubing runs as short as possible.
- Use the flare method for connecting tubing.
- Apply refrigerant lubricant to the matching surfaces of the flare and union tubes before connecting them, then tighten the nut with a torque wrench for a leak-free connection.
- Check carefully for leaks before starting the test run.

NOTE:

Depending on the system type, liquid and gas lines may be either narrow or wide. Therefore, to avoid confusion the refrigerant tubing for your particular model is specified as either "narrow" or "wide" rather than as "liquid" or "gas."

When Servicing

- Turn the power **OFF** at the main power box (mains) before opening the unit to check or repair electrical parts and wiring.
- Keep your fingers and clothing away from any moving parts.
- Clean up the site after you finish, remembering to check that no metal scraps or bits of wiring have been left inside the unit being serviced.

Table of Contents

	Page
1. OPERATING RANGE.....	1
2. SPECIFICATIONS	2
Unit Specifications	2
3. DIMENSIONAL DATA	3
4. COOLING CAPACITY.....	5
5. HEATING CAPACITY.....	7
6. REFRIGERANT FLOW DIAGRAM.....	9
7. ELECTRICAL DATA	10
● Electrical Characteristics	10
● Electric Wiring Diagram.....	11

1. OPERATING RANGE

THS2422 / CH2422

	Temperature	Indoor Air Intake Temp.	Outdoor Air Intake Temp.
Cooling	Maximum	95°F DB / 71°F WB	115°F DB
	Minimum	67°F DB / 57°F WB	67°F DB
Heating	Maximum	80°F DB / 67°F WB	75°F DB / 65°F WB
	Minimum	— DB / — WB	17°F DB / 15°F WB

2. SPECIFICATIONS

Unit Specifications

Model No.		Indoor unit	THS2422		
		Outdoor unit	CH2422		
Performance	Capacity	BTU/h	Cooling	Heating	
			22,000 / 21,400	23,400 / 22,800	
		kW	6.45 / 6.27	6.86 / 6.68	
	Air circulation (High)	cu. ft./min.	565 / 530		
Moisture removal (High)	Pints/h	6.3 / 6.2			
Electrical Rating	Phase, Frequency	Hz	Single, 60		
	Voltage rating	V	230 / 208	230 / 208	
	Available voltage range	V	187 to 253	187 to 253	
	Running amperes	A	10.7 / 11.3	11.7 / 12.9	
	Power input	W	2,290 / 2,250	2,530 / 2,480	
	Power factor	%	93 / 96	94 / 92	
	Starting amperes	A	66		
	S.E.E.R. (H.S.P.F.)	BTU/Wh	10.0 / 10.0	(6.8 / 6.8)	
	Heater element	kW	—	1.80 / 1.47	
Features	Controls	Microprocessor			
	Control unit	Wireless remote control unit			
	Temperature control	IC thermostat			
	Timer	ON/OFF, 24-hours & Program			
	Fan speeds	Indoor / Outdoor	3 and Auto / I		
	Air deflector	Horizontal / Vertical	Manual / Automatic		
	Air filter	Washable, easy access			
	Compressor	Rotary			
	Refrigerant amount charged at shipment	lbs. (kg)	R22: 7.48 (3.4)		
	Refrigerant control	Capillary tube			
	Refrigerant tubing connections	Flare type			
	Operation sound	In-Hi / Me / Lo	dB-A	45 / 41 / 37	
		Out-Hi	dB-A	52	
	Max. allowable tubing length at shipment	ft. (m)	50 (15)		
	Limit of tubing length	ft. (m)	100 (30)		
	Limit of elevation difference between the 2 units		Outdoor unit is higher than indoor unit: 50 (15)		
			Outdoor unit is lower than indoor unit: 50 (15)		
Refrigerant tube o.d.	Narrow tube	in. (mm)	1/4 (6.35)		
	Wide tube	in. (mm)	3/4 (19.05)		
Refrigerant tube kit	Optional				
Accessories	Mounting bracket				
Dimensions & Weight			Indoor unit	Outdoor unit	
	Height	in. (mm)	7-9/32 (185)	30-1/8 (765)	
	Width	in. (mm)	50 (1,270)	26-3/8 (670)	
	Depth	in. (mm)	26-3/8 (670)	26-3/8 (670)	
	Net weight	lbs. (kg)	67 (30.2)	185 (83.9)	
	Shipping volume	cu. ft. (cu. m)	10.4 (0.29)	16.3 (0.461)	
Shipping weight (Approx.)	lbs. (kg)	100 (45)	202 (91.6)		

DATA SUBJECT TO CHANGE WITHOUT NOTICE.

Remarks: Rating conditions are:

Cooling: Outside air temperature 95°F DB/75°F WB

Indoor unit entering air temperature 80°F DB/67°F WB

Heating: Outside air temperature 47°F DB/43°F WB

Indoor unit entering air temperature 70°F WB

3. DIMENSIONAL DATA

Indoor Unit: THS2422

①	Refrigerant gas line (wide tube)	O.D. 3/4"
②	Refrigerant liquid line (narrow tube)	O.D. 1/4"
③	Drain connection	
④	Power supply	

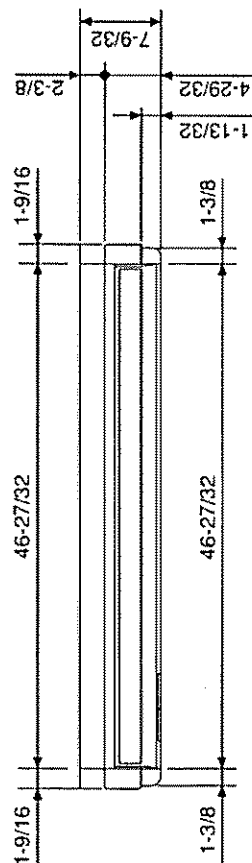
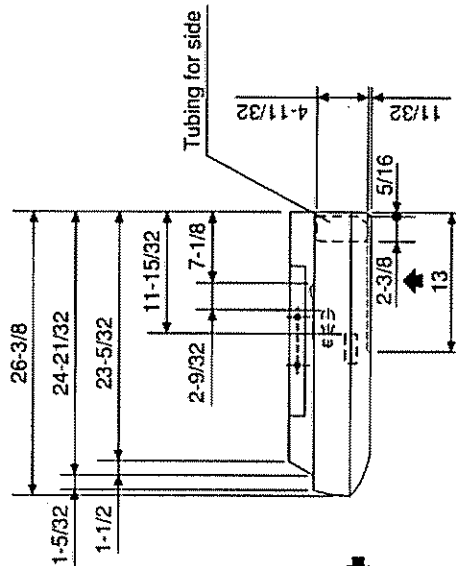
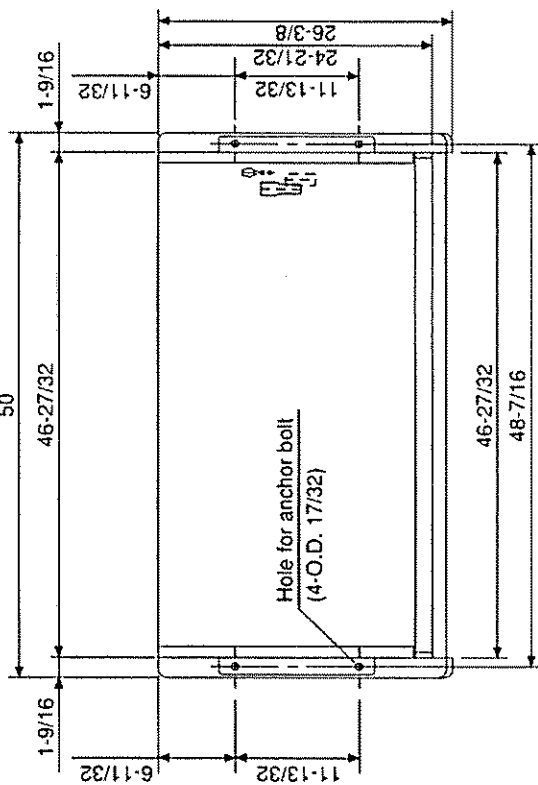
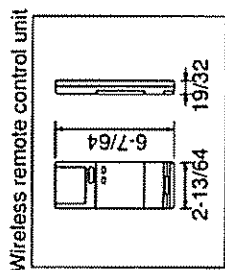
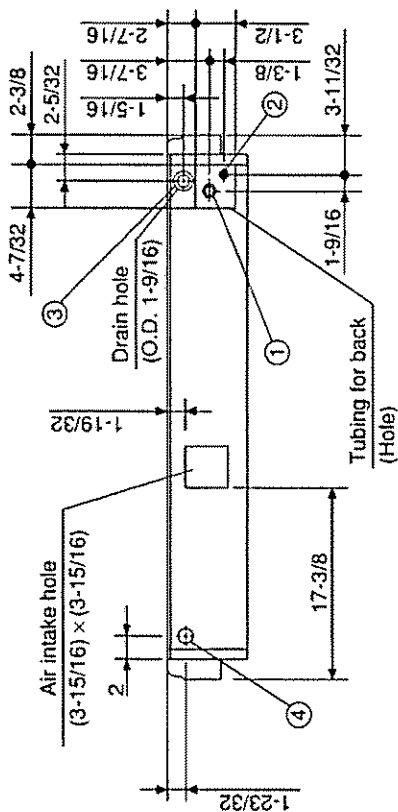

Outdoor Unit: CH2422

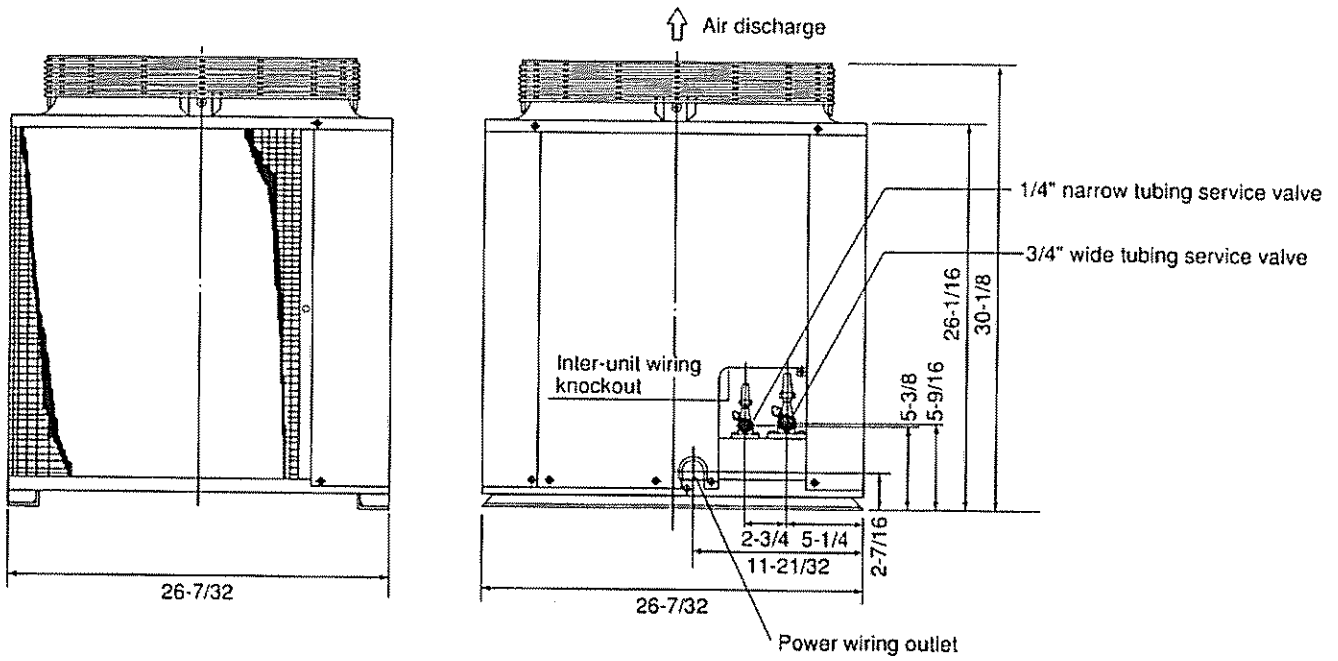
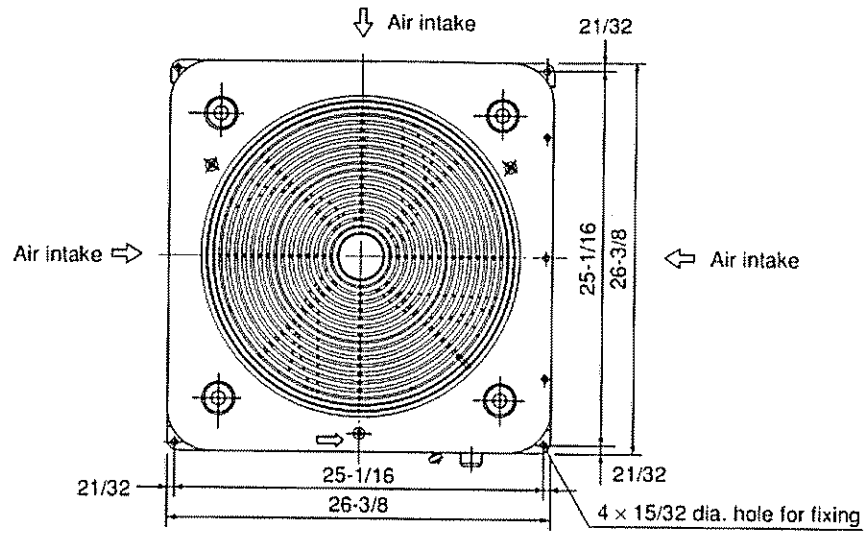

4. COOLING CAPACITY

230V

THS2422 / CH2422

Rating Capacity: 22,000 BTU/H			Air Flow Rate: 565 CFM				
Evaporator		Condenser					
Ent. Temp. °F/(°C)		Ambient Temp. °F/(°C)					
WB	DB		75 (23.9)	85 (29.4)	95 (35.0)	105 (40.6)	115 (46.1)
59 (15.0)		TC	21,780	20,790	19,800	18,680	17,160
		kW	1.59	1.74	1.89	2.05	2.25
	72 (22.2)	SHC	15,700	15,190	14,690	14,130	13,390
	76 (24.4)	SHC	17,660	17,150	16,650	16,090	15,350
	80 (26.7)	SHC	19,710	19,200	18,700	18,140	17,160
	84 (28.9)	SHC	21,670	20,790	19,800	18,680	17,160
	88 (31.1)	SHC	21,780	20,790	19,800	18,680	17,160
63 (17.2)		TC	22,530	21,820	20,970	19,820	18,260
		kW	1.61	1.76	1.92	2.09	2.30
	72 (22.2)	SHC	13,240	12,910	12,500	11,980	11,270
	76 (24.4)	SHC	15,200	14,870	14,460	13,940	13,230
	80 (26.7)	SHC	17,250	16,920	16,510	15,990	15,280
	84 (28.9)	SHC	19,210	18,880	18,470	17,950	17,240
	88 (31.1)	SHC	21,170	20,840	20,430	19,820	18,260
67 (19.4)		TC	23,140	22,770	*22,000	20,790	19,360
		kW	1.62	1.78	1.94	2.11	2.35
	72 (22.2)	SHC	10,700	10,530	10,200	9,690	9,100
	76 (24.4)	SHC	12,660	12,490	12,160	11,650	11,060
	80 (26.7)	SHC	14,710	14,540	14,210	13,700	13,110
	84 (28.9)	SHC	16,670	16,500	16,170	15,660	15,070
	88 (31.1)	SHC	18,630	18,460	18,130	17,620	17,030
71 (21.7)		TC	23,870	23,470	22,880	21,850	20,570
		kW	1.64	1.79	1.97	2.17	2.40
	72 (22.2)	SHC	8,080	7,930	7,700	7,300	6,820
	76 (24.4)	SHC	10,040	9,890	9,660	9,260	8,780
	80 (26.7)	SHC	12,090	11,940	11,700	11,310	10,830
	84 (28.9)	SHC	14,050	13,900	13,660	13,270	12,790
	88 (31.1)	SHC	16,010	15,860	15,620	15,230	14,750
75 (23.9)		TC	24,330	24,070	23,540	22,700	21,780
		kW	1.67	1.82	2.00	2.22	2.45
	76 (24.4)	SHC	7,440	7,340	7,160	6,870	6,550
	80 (26.7)	SHC	9,490	9,390	9,210	8,920	8,600
	84 (28.9)	SHC	11,450	11,350	11,170	10,880	10,560
	88 (31.1)	SHC	13,400	13,310	13,130	12,840	12,520

TC: Total Cooling Capacity (BTU/H)
 SHC: Sensible Heat Capacity (BTU/H)
 kW: Compressor Input (kW)

Remarks: Rating conditions (* mark) are: Outdoor ambient temperature 95°F DB

Indoor unit entering air temperature 80°F DB/67°F WB

Rating Capacity: 21,400 BTU/H			Air Flow Rate: 530 CFM				
Evaporator		Condenser					
Ent. Temp. °F/(°C)		Ambient Temp. °F/(°C)					
WB	DB		75 (23.9)	85 (29.4)	95 (35.0)	105 (40.6)	115 (46.1)
59 (15.0)		TC kW	21,190 1.57	20,220 1.72	19,260 1.87	18,170 2.03	16,690 2.23
	72 (22.2)	SHC	15,160	14,660	14,160	13,610	12,890
	76 (24.4)	SHC	17,020	16,510	16,020	15,470	14,750
	80 (26.7)	SHC	18,960	18,460	17,960	17,410	16,690
	84 (28.9)	SHC	20,820	20,220	19,260	18,170	16,690
	88 (31.1)	SHC	21,190	20,220	19,260	18,170	16,690
63 (17.2)		TC kW	21,910 1.59	21,230 1.74	20,390 1.90	19,280 2.06	17,760 2.28
	72 (22.2)	SHC	12,810	12,480	12,090	11,570	10,880
	76 (24.4)	SHC	14,670	14,340	13,950	13,430	12,740
	80 (26.7)	SHC	16,610	16,280	15,890	15,370	14,680
	84 (28.9)	SHC	18,470	18,140	17,750	17,230	16,540
	88 (31.1)	SHC	20,330	20,000	19,600	19,090	17,760
67 (19.4)		TC kW	22,510 1.60	22,150 1.76	*21,400 1.92	20,220 2.09	18,830 2.32
	72 (22.2)	SHC	10,380	10,220	9,900	9,390	8,810
	76 (24.4)	SHC	12,240	12,080	11,750	11,250	10,670
	80 (26.7)	SHC	14,180	14,020	13,700	13,190	12,610
	84 (28.9)	SHC	16,040	15,880	15,550	15,050	14,470
	88 (31.1)	SHC	17,900	17,740	17,410	16,910	16,330
71 (21.7)		TC kW	23,220 1.62	22,830 1.78	22,260 1.95	21,250 2.15	20,010 2.37
	72 (22.2)	SHC	7,880	7,730	7,510	7,120	6,640
	76 (24.4)	SHC	9,740	9,590	9,360	8,970	8,500
	80 (26.7)	SHC	11,680	11,530	11,310	10,920	10,440
	84 (28.9)	SHC	13,540	13,390	13,160	12,770	12,300
	88 (31.1)	SHC	15,400	15,250	15,020	14,630	14,160
75 (23.9)		TC kW	23,670 1.65	23,410 1.80	22,900 1.98	22,080 2.20	21,190 2.43
	76 (24.4)	SHC	7,250	7,160	6,980	6,690	6,380
	80 (26.7)	SHC	9,190	9,100	8,920	8,640	8,330
	84 (28.9)	SHC	11,050	10,960	10,780	10,490	10,180
	88 (31.1)	SHC	12,910	12,820	12,640	12,350	12,040

TC: Total Cooling Capacity (BTU/H)
 SHC: Sensible Heat Capacity (BTU/H)
 kW: Compressor Input (kW)

Remarks: Rating conditions (* mark) are: Outside ambient temperature 95°F DB
 Indoor unit entering air temperature 80°F DB/67°F WB

5. HEATING CAPACITY

THS2422 / CH2422

1 phase 60Hz 230V

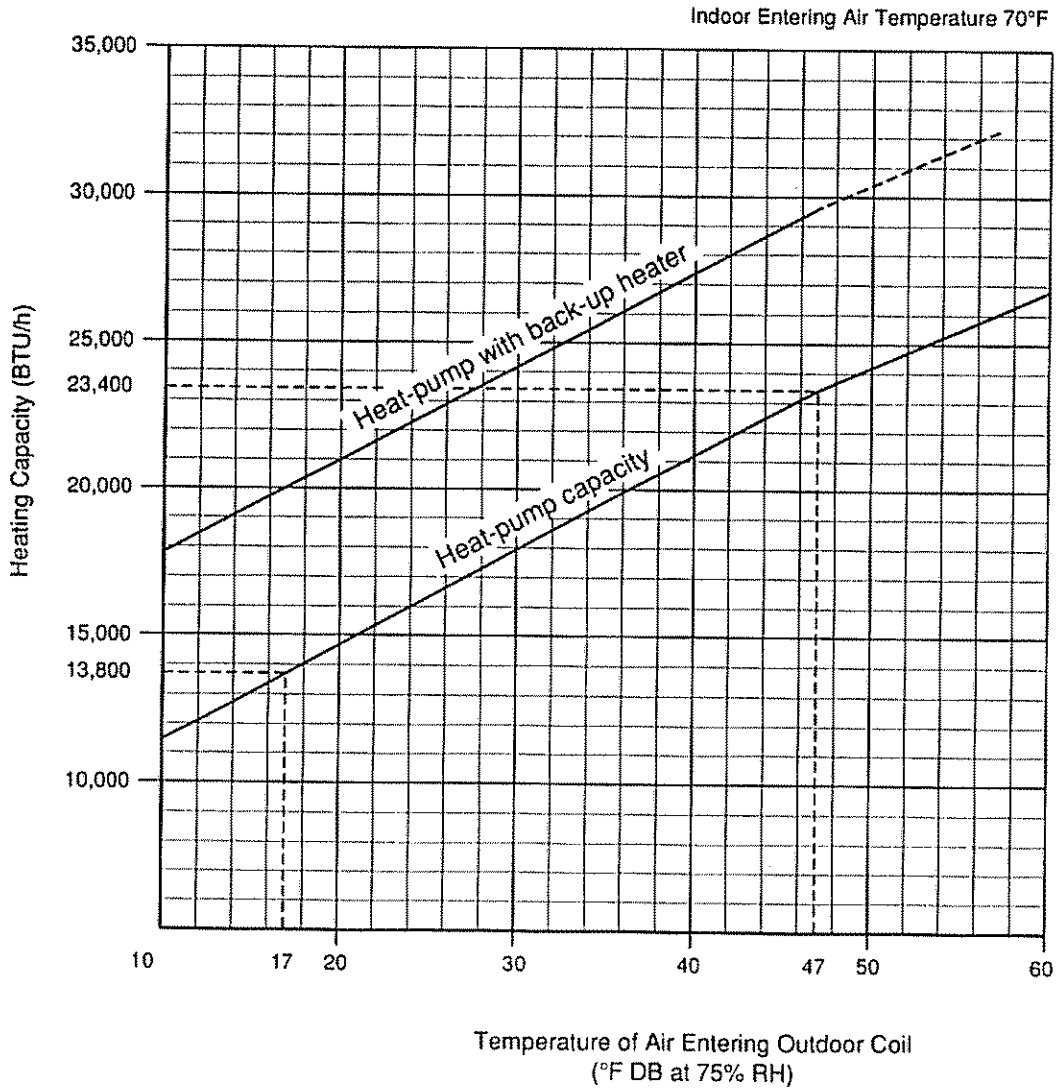

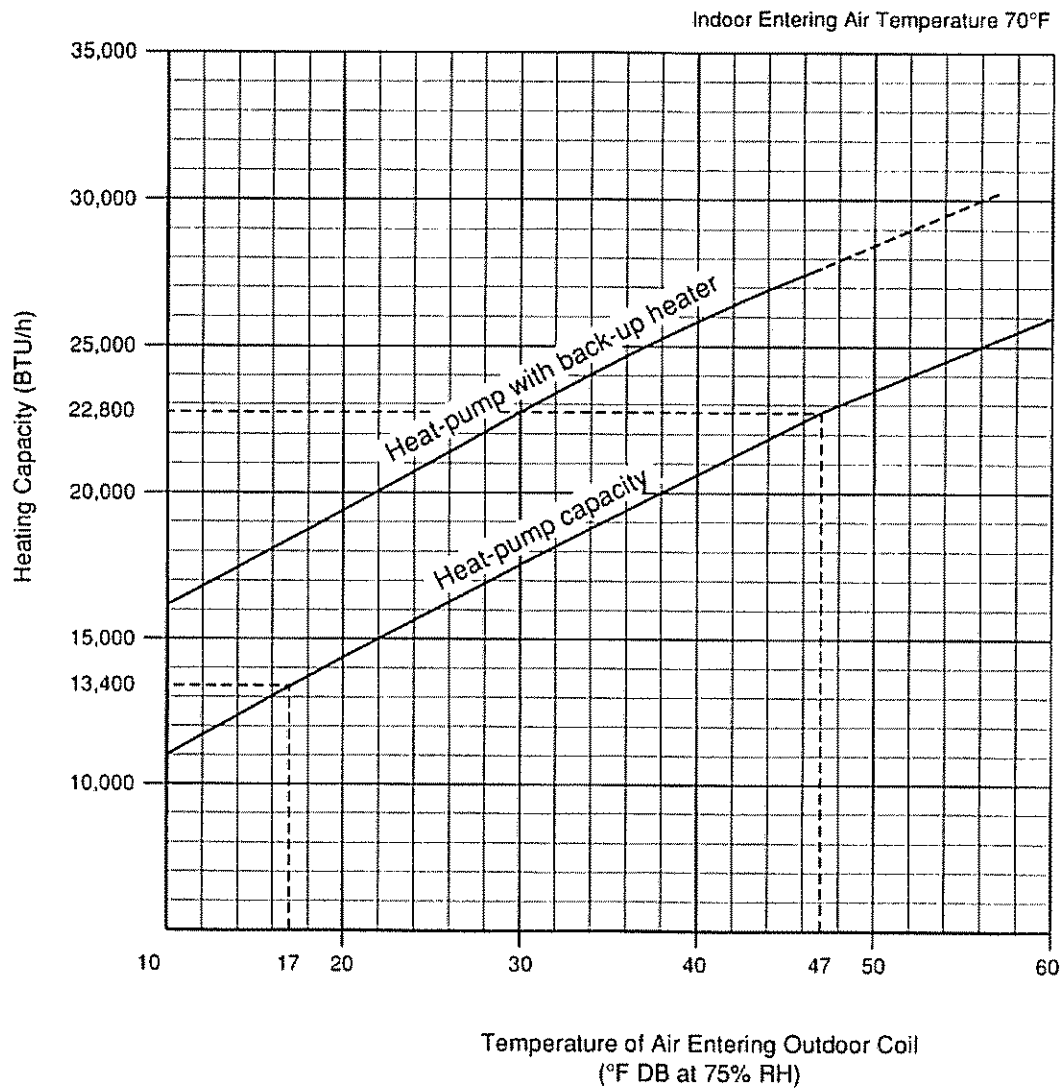

6. REFRIGERANT FLOW DIAGRAM

THS2422 / CH2422

Cooling Cycle

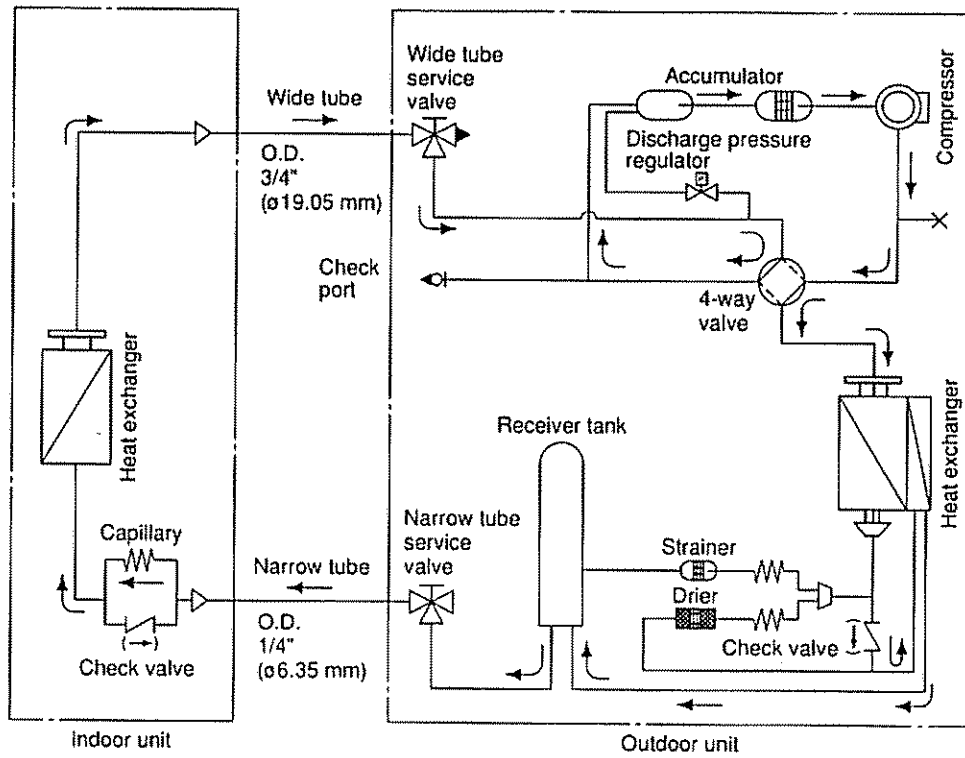

Heating Cycle

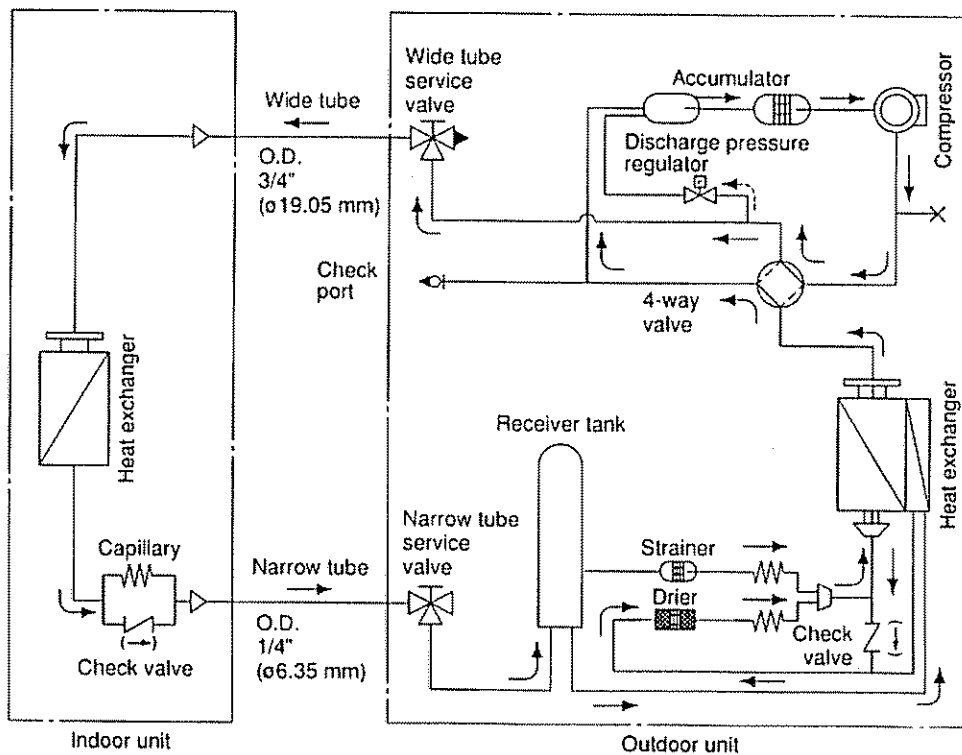

7. ELECTRICAL DATA

● Electrical Characteristics

THS2422 / CH2422

Performance at 230/208V – 1φ – 60Hz			Indoor Unit		Outdoor Unit		Complete Unit	
			Fan Motor	Max. Heat	Fan Motor	Compressor	Heat-pump	Max. Heat
Cooling	Rating Conditions	A	0.5 / 0.5	—	1.2 / 1.2	9.0 / 9.6	10.7 / 11.3	—
		W	100 / 100	—	250 / 230	1,940 / 1,920	2,290 / 2,250	—
Heating	Rating Conditions	A	0.5 / 0.5	7.8 / 7.1	1.2 / 1.2	10.0 / 11.2	11.7 / 12.9	19.5 / 20.0
		W	100 / 100	1,800 / 1,470	250 / 230	2,180 / 2,150	2,530 / 2,480	4,330 / 3,950
Locked-Rotor Amperes		A	0.53 / 0.50	—	2.34 / 2.29	66	—	—

Remarks: Rating conditions are:

Cooling: Outside air temperature 95°F DB/75°F WB

Indoor unit entering air temperature 80°F DB/67°F WB

Heating: Outside air temperature 47°F DB/43°F WB

Indoor unit entering air temperature 70°F WB

● Electric Wiring Diagram

Indoor Unit: THS2422



WARNING:

To avoid electrical shock hazard, be sure to disconnect power before checking, servicing and/or cleaning any electrical parts.

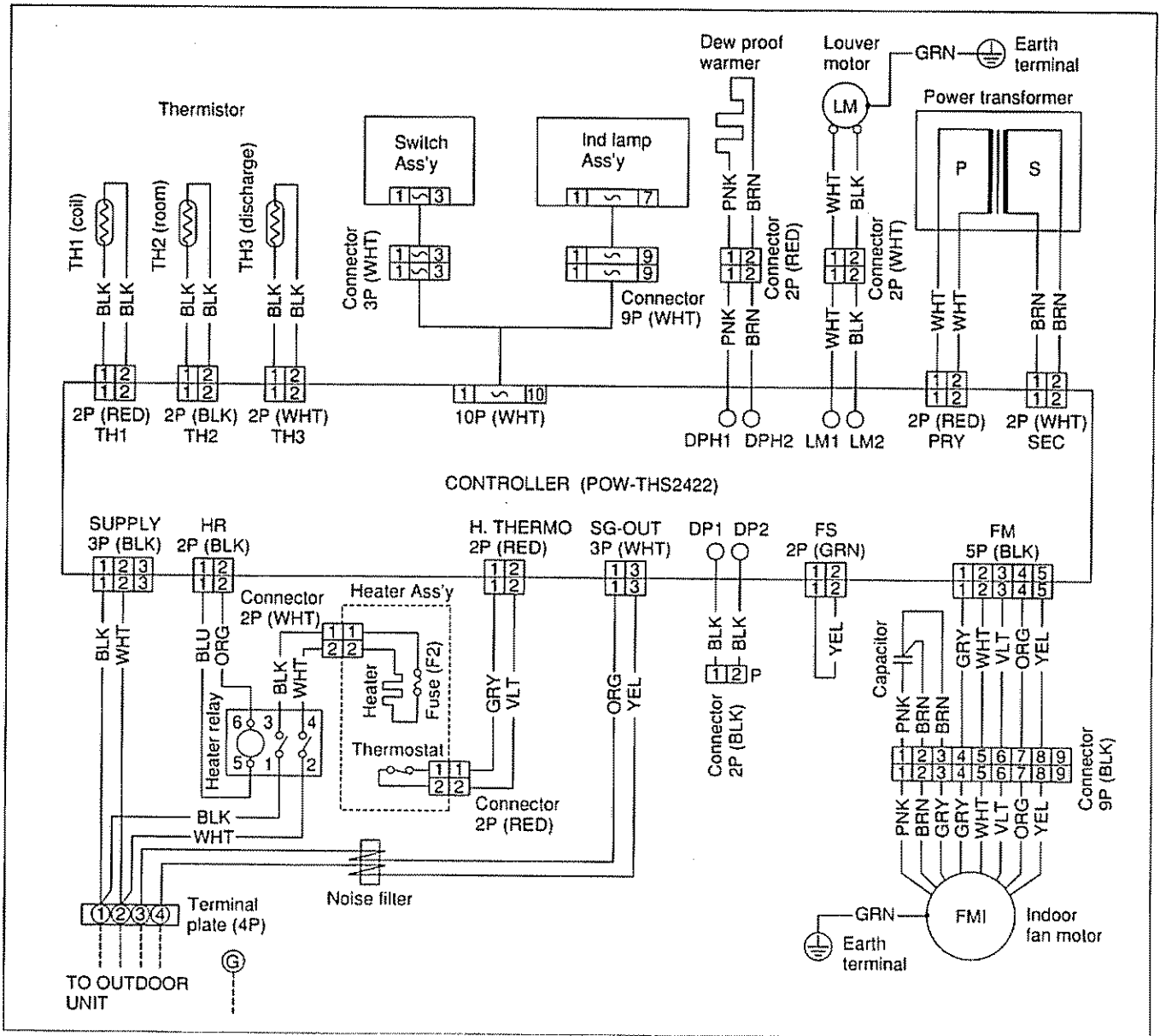



WARNING:

To avoid electrical shock hazard, be sure to disconnect power before checking, servicing and/or cleaning any electrical parts.

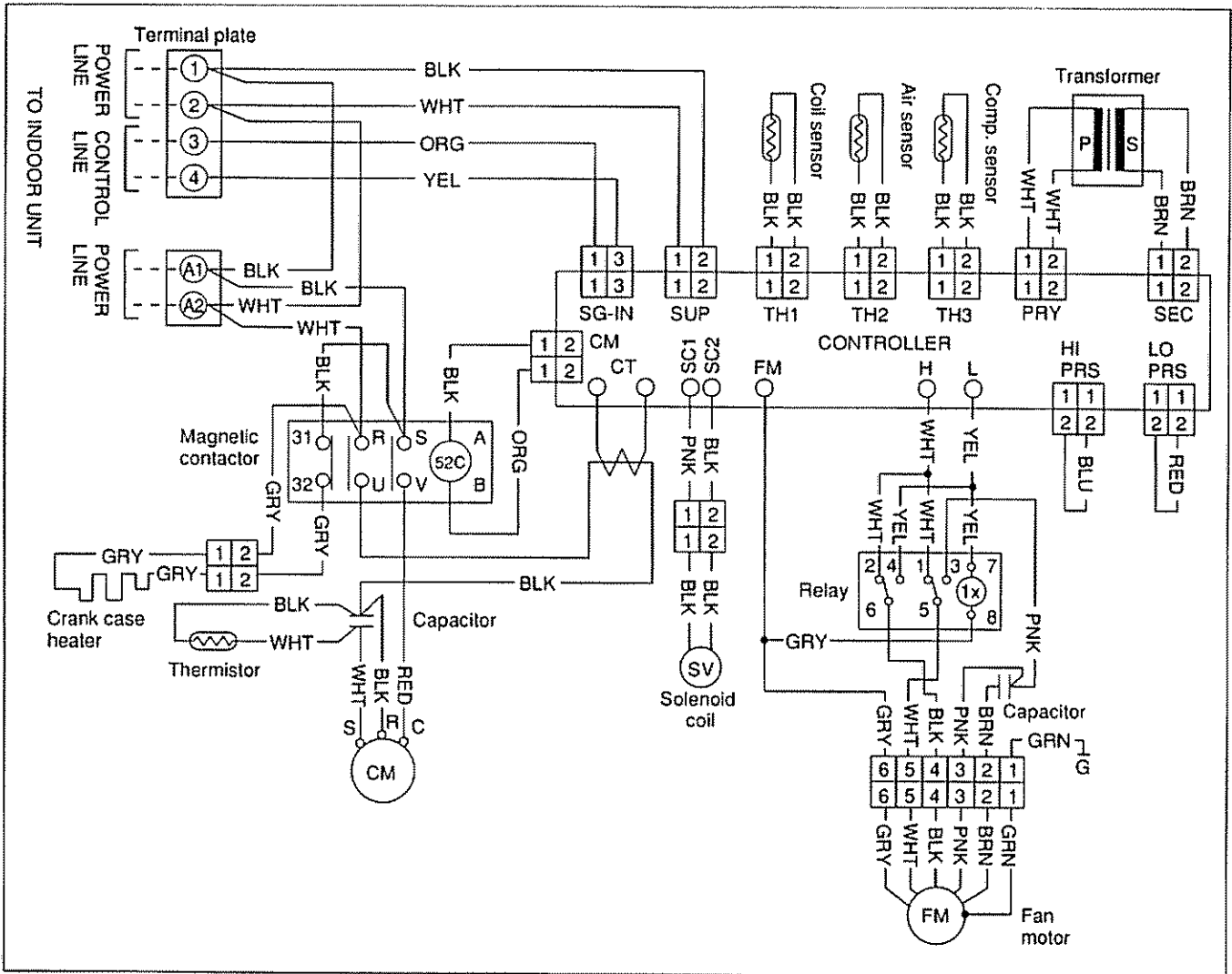

For parts or service contact



SFS Corporation: 1200 West Artesia Blvd., Compton, California 90220

In Canada SANYO Canada Inc.: Toronto, Ont. M4H 1M6

H408/12M

Printed in U.S.A.

WM-760706