

# MC50 & MC60 Microwave

## Manual for Installation, Use and Maintenance

# CDA





## INSTALLATION



### MOUNTING THE APPLIANCE



**FOLLOW THE SUPPLIED** separate mounting instructions when installing the appliance.

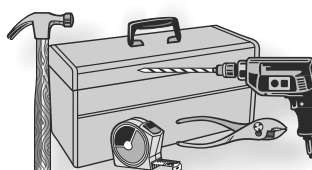

### PRIOR TO CONNECTING



**CHECK THAT THE VOLTAGE** on the rating plate corresponds to the voltage in your home.

**DO NOT REMOVE THE MICROWAVE INLET PROTECTION PLATES** located on the side of the oven cavity wall. They prevent grease & food particles from entering the microwave inlet channels.

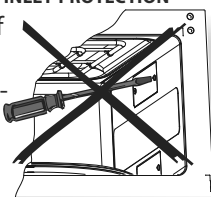

**ENSURE** the oven cavity is empty before mounting.

**ENSURE THAT THE APPLIANCE IS NOT DAMAGED.** Check that the oven door closes firmly against the door support and that the internal door seal is not damaged. Empty the oven and clean the interior with a soft, damp cloth.



**DO NOT OPERATE THIS APPLIANCE** if it has a damaged mains cord or plug, if it is not working properly, or if it has been damaged or dropped. Do not immerse the mains cord or plug in water. Keep the cord away from hot surfaces. Electrical shock, fire or other hazards may result.

### AFTER CONNECTING

**THE OVEN CAN BE OPERATED ONLY** if the oven door is firmly closed.



**THE EARTHING OF THIS APPLIANCE** is compulsory. The manufacturer will accept no responsibility for injury to persons, animals or damage to objects arising from the non-observance of this requirement.

**The manufacturers are not liable for any problems caused by the user's failure to observe these instructions.**



## IMPORTANT SAFETY INSTRUCTIONS



READ CAREFULLY AND KEEP FOR FUTURE REFERENCE



**DO NOT HEAT, OR USE FLAMMABLE MATERIALS** in or near the oven. Fumes can create a fire hazard or explosion.



**DO NOT USE YOUR MICROWAVE** oven for drying textiles, paper, spices, herbs, wood, flowers, fruit or other combustible materials. Fire could result.



**IF MATERIAL INSIDE / OUTSIDE THE OVEN SHOULD IGNITE OR SMOKE IS OBSERVED**, keep oven door closed and turn the oven off. Disconnect the power cord or shut off power at the fuse or circuit breaker panel.



**DO NOT OVER-COOK FOOD.** Fire could result.



**DO NOT LEAVE THE OVEN UNATTENDED**, especially when using paper, plastic or other combustible materials in the cooking process. Paper can char or burn and some plastics can melt if used when heating foods.



**DO NOT USE** corrosive chemicals or vapors in this appliance. This type of oven is specifically designed to heat or cook food. It is not designed for industrial or laboratory use.



**ONLY ALLOW CHILDREN** to use the oven without adult supervision after adequate instructions have been given so that the child is able to use the oven in a safe way and understands the hazards of improper use. The appliance is not intended for use by young children or infirm persons without supervision. Young children should be supervised to ensure that they do not play with the appliance. If your oven has a combination mode, children should only use the oven under adult supervision due to the high temperatures generated.



**DO NOT USE YOUR MICROWAVE** oven for heating anything in airtight sealed containers. The pressure increases and may cause damage when opening or may explode.

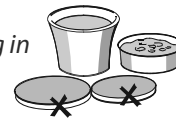

**THE DOOR SEALS AND THE DOOR SEAL AREAS** must be regularly inspected for damage. If these areas are damaged the appliance should not be operated until it has been repaired by a trained service technician.

### EGGS

**DO NOT USE YOUR MICROWAVE** oven for cooking or reheating whole eggs with or without shell since they may explode even after microwave heating has ended.





## PRECAUTIONS



### GENERAL

***THIS APPLIANCE IS DESIGNED FOR DOMESTIC USE ONLY!***

***THE APPLIANCE SHOULD NOT BE OPERATED without food in the oven when using microwaves. Operation in this manner is likely to damage the appliance.***

**IF YOU PRACTICE OPERATING** the oven, put a glass of water inside. The water will absorb the microwave energy and the oven will not be damaged.

**DO NOT USE THE CAVITY** for any storage purposes.

**REMOVE WIRE TWIST-TIES** from paper or plastic bags before placing bag in the oven.



### DEEP-FRYING

**DO NOT USE YOUR MICROWAVE oven** for deep-frying, because the oil temperature cannot be controlled.



**USE HOT PADS OR OVEN MITTS** to prevent burns, when touching containers, oven parts, and pan after cooking.

### LIQUIDS

**E.G. BEVERAGES OR WATER.** Overheating the liquid beyond boiling point can occur without evidence of bubbling. This could result in a sudden boil over of the hot liquid. To prevent this possibility the following steps should be taken:



1. Avoid using straight-sided containers with narrow necks.
2. Stir the liquid before placing the container in the oven and let the teaspoon remain in the container.
3. After heating, allow standing for a short time, stirring again before carefully removing the container from the oven.

### CAREFUL

**ALWAYS REFER** to a microwave cookbook for details. Especially, if cooking or reheating food that contains alcohol.

**AFTER HEATING BABY FOOD** or liquids in a baby bottle or in a baby food jar, always stir and check the temperature before serving.



*This will ensure that the heat is evenly distributed and the risk of scalding or burns can be avoided.*

**Ensure the Lid and the Teat is removed before heating!**



## ACCESSORIES



### GENERAL

**THERE ARE** a number of accessories available on the market. Before you buy, ensure they are suitable for microwave use.

**ENSURE THAT THE UTENSILS YOU USE** are oven proof and allow microwaves to pass through them before cooking.



**WHEN YOU PUT FOOD AND ACCESSORIES** in the microwave oven, ensure that they do not come in contact with the interior of the oven.

**This is especially important with accessories made of metal or metal parts.**

**IF ACCESSORIES CONTAINING METAL** comes in contact with the oven interior, while the oven is in operation, sparking can occur and the oven could be damaged.

**ALWAYS ENSURE** that the turntable is able to turn freely before starting the oven.

### TURNTABLE SUPPORT

**USE THE TURNTABLE SUPPORT** under the Glass turntable. Never put any other utensils on the turntable support.

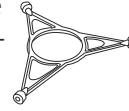

☞ Fit the turntable support in the oven.

### GLASS TURNTABLE

**USE THE GLASS TURNTABLE** with all cooking methods. It collects the dripping juices and food particles that otherwise would stain and soil the interior of the oven.



☞ Place the Glass turntable on the turntable support.



## START PROTECTION / CHILD LOCK



**THIS AUTOMATIC SAFETY FUNCTION IS ACTIVATED ONE MINUTE AFTER** the oven has returned to "stand by mode". (The oven is in "stand by" when the 24-hour clock is displayed or if the clock has not been set, when the display is blank).



**THE DOOR MUST BE OPENED AND CLOSED** e.g. putting food into it, before the safety lock is released. Else the display will show "door".

door



## COOLING DOWN



**WHEN A FUNCTION IS FINISHED**, the oven carries out a cooling procedure. This is normal. After this procedure the oven switches off automatically.

**THE COOLING PROCEDURE** can be interrupted without any harm to the oven by opening the door.



## CLOCK



**KEEP THE DOOR OPEN** while setting the Clock. This gives you 5 minutes to complete the setting of the Clock. Otherwise, each step must be accomplished within 30 seconds.

**NOTE:** When the appliance is first plugged in or after a power failure, the display is blank. If the clock is not set, the display will remain blank until the cooking time is set.

1. **PRESS THE CLOCK BUTTON** (3 seconds) until the left-hand digit (hour's) flicker.
  2. **PRESS THE +/- BUTTONS** to set the hours.
  3. **PRESS THE CLOCK BUTTON AGAIN.** (The two right hand digits (minutes) flicker).
  4. **PRESS THE +/- BUTTONS** to set the minutes.
  5. **PRESS THE CLOCK BUTTON AGAIN.**
- THE CLOCK IS SET** and in operation.

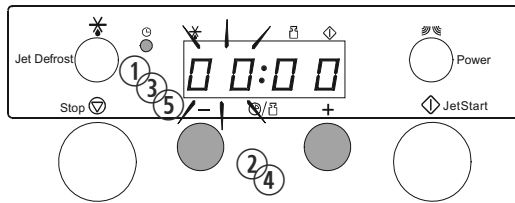

## KITCHEN TIMER



**USE THIS FUNCTION** when you need a kitchen timer to measure time for various purposes such as cooking eggs or letting the dough rise before baking etc.

**AN ACOUSTIC SIGNAL** will be heard when the timer has finished to count down.

1. **PRESS THE +/- BUTTONS** to set the desired length of the timer.
2. **PRESS THE POWER BUTTON** repeatedly to set the power to 0 W.
3. **PRESS THE START BUTTON.**

**4. TO TURN THE KITCHEN TIMER OFF** before the count-down have finished, press the Stop button.

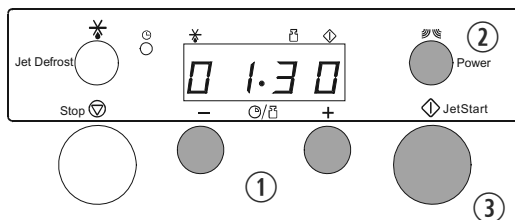



## COOK & REHEAT WITH MICROWAVES



**USE THIS FUNCTION** for normal cooking and re-heating, such as vegetables, fish, potatoes and meat.

1. **PRESS THE +/- BUTTONS** to set the time.
2. **PRESS THE POWER BUTTON** repeatedly to set the power.
3. **PRESS THE START BUTTON.**

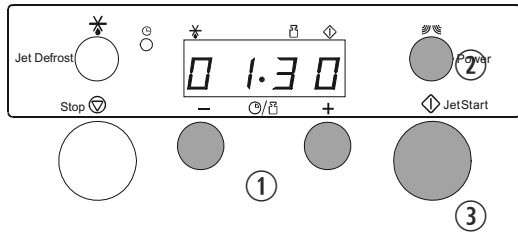

**ONCE THE COOKING PROCESS HAS BEEN STARTED:**

The time can easily be increased in 30-second steps by pressing the Start button. *Each press* increases the time with 30 seconds.

**YOU MAY ALSO ALTER THE TIME** by pressing the +/- buttons to increase or decrease the time.

**PRESSING THE POWER BUTTON** may also change the power level. The first press will show you the current power level. Press the power button repeatedly to change power level.

### POWER LEVEL

MICROWAVES ONLY	
POWER	SUGGESTED USE:
750 W	<b>REHEATING OF BEVERAGES</b> , water, clear soups, coffee, tea or other food with a high water content. If the food contains egg or cream choose a lower power. Cooking of fish vegetables, meat, etc
500 W	<b>MORE CAREFUL COOKING</b> e.g. high protein sauces, cheese and egg dishes and to finish cooking casseroles.
350 W	<b>SIMMERING STEWS</b> , melting butter.
160 W	<b>DEFROSTING</b> . Softening butter, cheeses and ice cream.
0 W	<b>WHEN USING THE TIMER</b> only.



## JET START



**THIS FUNCTION IS USED** for quick reheating of food with a high water content such as; clear soups, coffee or tea.

**1. PRESS THE START BUTTON.**

**THIS FUNCTION AUTOMATICALLY STARTS** with maximum microwave power level and the cooking time set to 30 seconds. *Each additional press* increases the time with 30 seconds.

**YOU MAY ALSO ALTER THE TIME** by pressing the +/- buttons to increase or decrease the time.

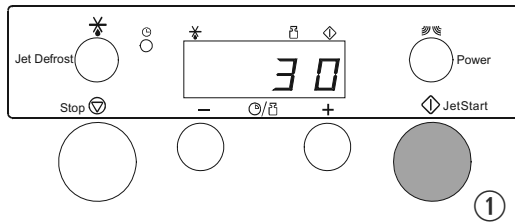

## MANUAL DEFROST



**FOLLOW THE PROCEDURE** for "How to cook & reheat with microwaves" and choose power level 160 W when defrosting manually.

**CHECK AND INSPECT THE FOOD REGULARLY.** Experience will give you the times needed for various amounts.

**FROZEN FOOD IN PLASTIC BAGS,** plastic films or cardboard packages can be placed directly in the oven as long as the package has no metal parts (e.g. metal twist ties).

**TURN LARGE JOINTS** halfway through the defrosting process.

**THE SHAPE OF THE PACKAGE** alters the defrosting time. Shallow packets defrost more quickly than a deep block.



**BOILED FOOD, STEWS AND MEAT SAUCES** defrost better if stirred during defrosting time.

**WHEN DEFROSTING** it is better to under-thaw the food slightly and allow the process to finish during standing time.

**SEPARATE PIECES** as they begin to defrost. Individual slices defrost more easily.

**STANDING TIME AFTER DEFROSTING ALWAYS IMPROVES** the result since the temperature will then be evenly distributed throughout the food.

**SHIELD AREAS OF FOOD** with small pieces of aluminum foil if they start to become warm (e.g. chicken legs and wing tips).

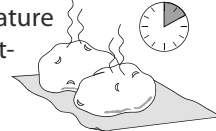
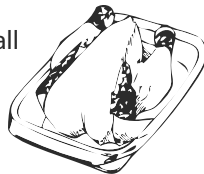





## JET DEFROST



**USE THIS FUNCTION** for defrosting Meat, Poultry, Fish, Vegetables and Bread.

JET Defrost should only be used if the net weight is between 100 g- 2.0 kg.

**ALWAYS PLACE THE FOOD** on the glass turntable.

**1. PRESS THE JET DEFROST BUTTON.**

**2. PRESS THE + / - BUTTONS** to set the weight of the food.

**5. PRESS THE START BUTTON.**

**MIDWAY THROUGH THE DEFROSTING PROCESS** the oven stops and prompts you to *turn Food*.

↻ Open the door.

↻ Turn the food.

↻ Close the door and restart by pressing the Start button.

**NOTE:** The oven continues automatically after 2 min. if the food hasn't been turned. The defrosting time will be longer in this case.

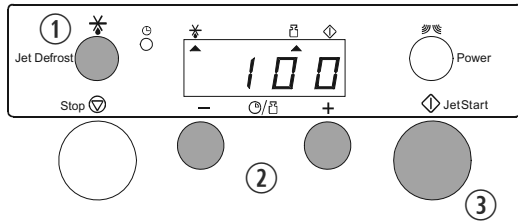

**THIS FUNCTION NEEDS TO KNOW** the net weight of the food. The oven will then automatically calculate the needed time to finish the procedure.



**IF THE WEIGHT IS LESSER OR GREATER THAN RECOMMENDED WEIGHT:** Follow the procedure for "Cook & Re-heat with microwaves" and choose 160 W when defrosting.

**FROZEN FOODS:**

**IF THE FOOD IS WARMER** than deep-freeze temperature (-18°C), choose lower weight of the food.

**IF THE FOOD IS COLDER** than deep-freeze temperature (-18°C), choose higher weight of the food.



## MAINTENANCE & CLEANING

**CLEANING IS THE ONLY MAINTENANCE** normally required.

**FAILURE TO MAINTAIN THE OVEN** in a clean condition could lead to deterioration of the surface that could adversely affect the life of the appliance and possibly result in a hazardous situation.

 **DO NOT USE METAL SCOURING PADS, ABRASIVE CLEANSERS, steel-wool pads, gritty wash-cloths, etc. which can damage the control panel, and the interior and exterior oven surfaces. Use a sponge with a mild detergent or a paper towel with spray glass cleaner. Apply spray glass cleaner to a paper towel. Do NOT SPRAY directly on the oven.**

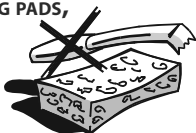

**AT REGULAR INTERVALS**, especially if spill overs have occurred, remove the turntable, the turntable support and wipe the base of the oven clean.



**THIS OVEN IS DESIGNED** to operate with the turntable in place.

 **Do NOT** operate the microwave oven when the turntable has been removed for cleaning.

**USE A MILD DETERGENT**, water and a soft cloth to clean the interior surfaces, front and rear of the door and the door opening.

 **Do NOT ALLOW GREASE** or food particles to build up around the door.

**FOR STUBBORN STAINS**, boil a cup of water in the oven for 2 or 3 minutes. Steam will soften the marks.

 **Do NOT USE STEAM CLEANING APPLIANCES** when cleaning your microwave oven.

**ADDING SOME LEMON JUICE** to a cup of water, placing this on the turntable and boiling for a few minutes can eliminate odors inside the oven.

DISHWASHER SAFE:

**TURNTABLE SUPPORT.**

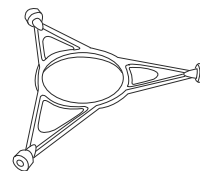

**GLASS TURNTABLE.**



## TROUBLE SHOOTING GUIDE

**IF THE OVEN DOES NOT WORK**, do not make a service call until you have made the following checks:

- ❗ The Turntable and turntable support is in place.
- ❗ The Plug is properly inserted in the wall socket.
- ❗ The Door is properly closed.
- ❗ Check your Fuses and ensure that there is power available.
- ❗ Check that the oven has ample ventilation.
- ❗ Wait for 10 minutes, then try to operate the oven once more.
- ❗ Open and then close the door before you try again.

**THIS IS TO AVOID** unnecessary calls for which you will be charged.

When calling for Service, please give the serial number and type number of the oven (see Service label). Consult your warranty booklet for further advice.



**IF THE MAINS CORD NEEDS REPLACING** it should be replaced by the original mains cord, which is available via our service organization. The mains cord may only be replaced by a trained service technician.



**SERVICE ONLY TO BE CARRIED OUT BY A TRAINED SERVICE TECHNICIAN.**

*It is hazardous for anyone other than a trained person to carry out any service or repair operation, which involves the removal of any cover, which gives protection against exposure to microwave energy.*

**DO NOT REMOVE ANY COVER.**

---

## ENVIRONMENTAL HINTS

**THE PACKING BOX** may be fully recycled as confirmed by the recycling symbol. Follow local disposal regulations. Keep potentially hazardous packaging (plastic bags, polystyrene etc.) out of the reach of children.



**THIS APPLIANCE** is marked according to the European directive 2002/96/EC on Waste Electrical and Electronic Equipment (WEEE). By ensuring this product is disposed of correctly, you will help prevent potential negative consequences for the environment and human health, which could otherwise be caused by inappropriate waste handling of this product.

**THE SYMBOL** on the product, or on the documents accompanying the product, indicates that this appliance may not be treated as household waste. Instead it shall be handed over to the applicable collection point for the recycling of electrical and electronic equipment.



**DISPOSAL** must be carried out in accordance with local environmental regulations for waste disposal.

**FOR MORE DETAILED INFORMATION** about treatment, recovery and recycling of this product, please contact your local city office, your household waste disposal service or the shop where you purchased the product.

**BEFORE SCRAPPING**, cut off the mains cord so that the appliance cannot be connected to the mains.

## TECHNICAL DATA

	MC 60	MC 50
<b>SUPPLY VOLTAGE</b>	230 V/50 Hz	
<b>RATED POWER INPUT</b>	1300 W	
<b>FUSE</b>	10 A (UK 13 A)	
<b>MW OUTPUT POWER</b>	750 W	
<b>OUTER DIMENSIONS (HxWxD)</b>	382 x 595 x 320	382 x 495 x 320
<b>INNER DIMENSIONS (HxWxD)</b>	187 x 370 x 290	

**IN ACCORDANCE WITH IEC 60705.**

**THE INTERNATIONAL ELECTROTECHNICAL COMMISSION**, has developed a standard for comparative testing of heating performance of different microwave ovens. We recommend the following for this oven:

Test	Amount	Approx. time	Power level	Container
12.3.1	1000 g	11 min	750 W	Pyrex 3.227
12.3.2	475 g	5 min	750 W	Pyrex 3.827
12.3.3	900 g	15 min	750 W	Pyrex 3.838
12.3.4	1100 g	28-30 min	Forced air 200 °C + 350 W	Pyrex 3.827
12.3.5	700 g	25 min	Forced air 200 °C + 90 W	Pyrex 3.827
12.3.6	1000 g	30-32 min	Forced air 225 °C + 350 W	Pyrex 3.827
13.3	500 g	2 min 12 sec	Jet defrost	



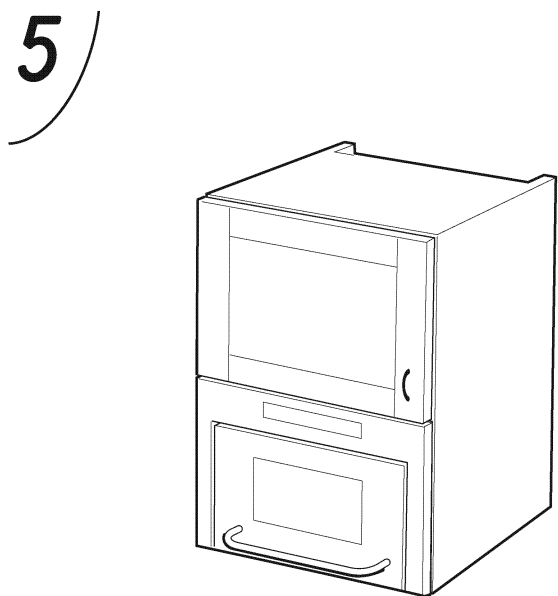
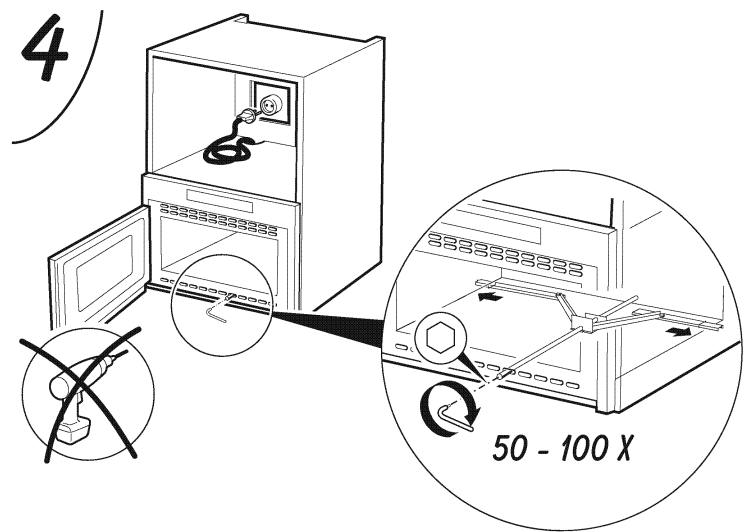
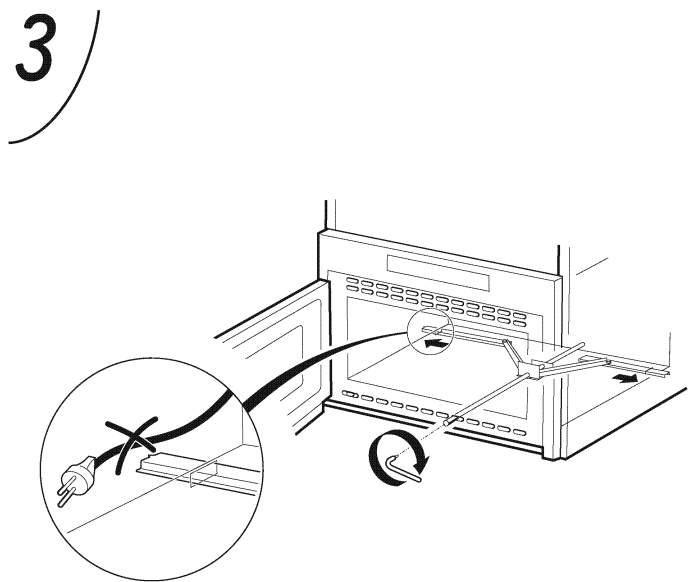
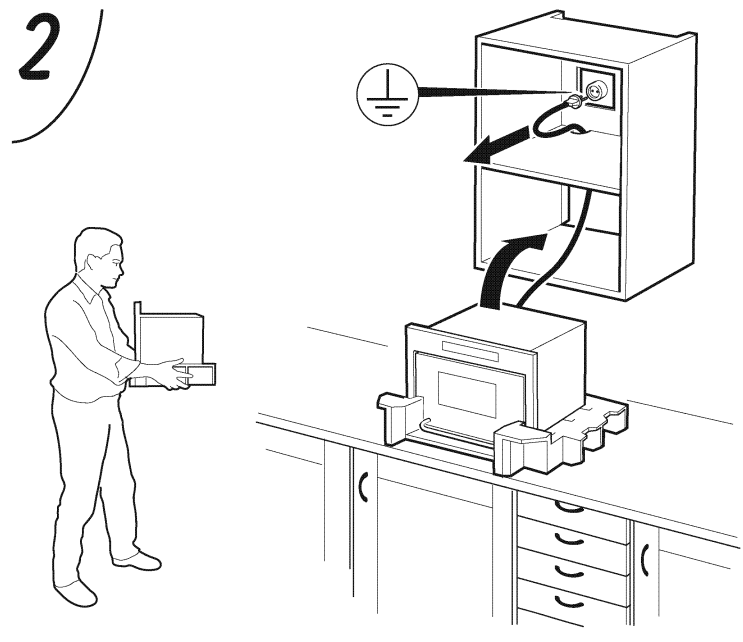
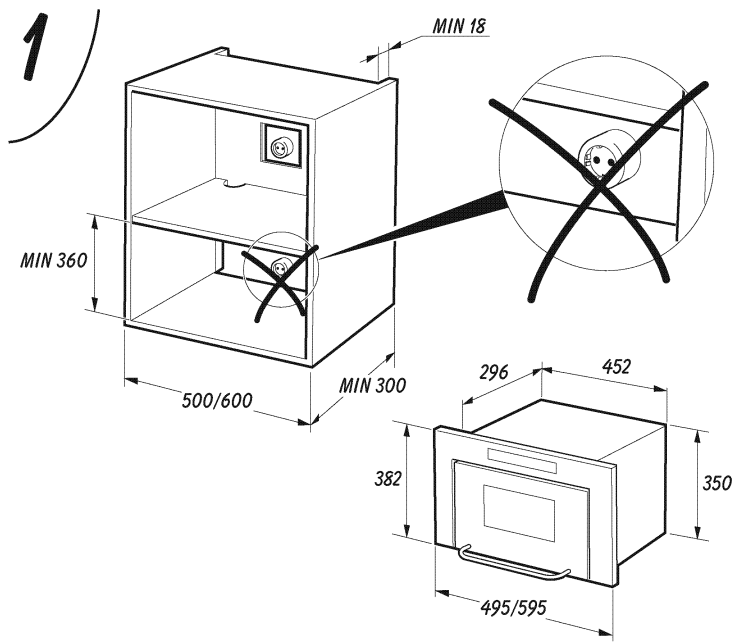

4619 694 41513



**Notes :**





**Notes :**





To contact our Customer Care Department, or for Service,  
please contact us on the details below.