

# Micro Dimmer

## Owner's Manual

2442-222 (US)

2442-422 (EU)

2442-522 (AUS/NZ)

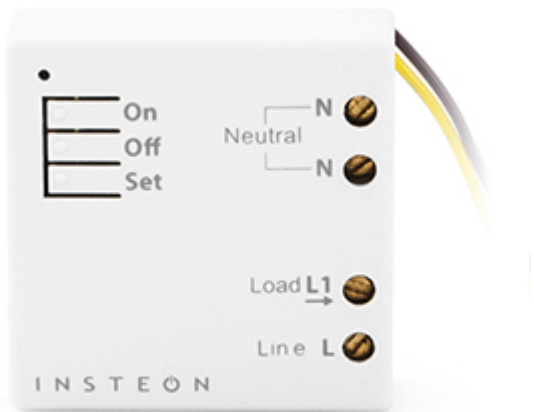

North America

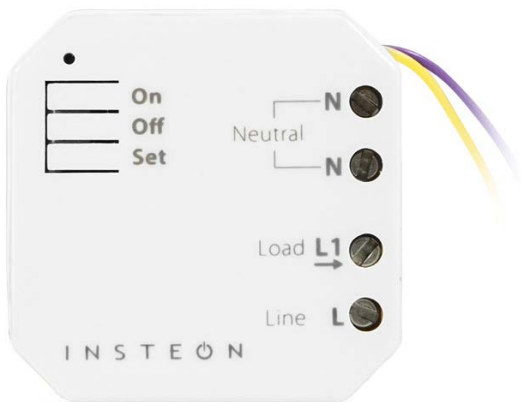

EU/AUS/NZ

Z  
G  
E  
T  
S  
N  
I

<b>About Micro Dimmer .....</b>	<b>4</b>
<i>Features and Benefits .....</i>	4
<b>Before Installation .....</b>	<b>4</b>
Identifying the Electrical Wires in Your Home (North America only) .....	5
Identifying the Electrical Wires in Your Home (Europe/Australia/New Zealand) .....	5
Identify Switch Type .....	5
<b>Installation .....</b>	<b>6</b>
<b>Switch Operation Mode .....</b>	<b>7</b>
Change to Single Momentary Mode .....	7
Change to Dual Momentary Mode .....	7
Change to Latching Mode (default) .....	8
<b>3-Way Toggle Mode (Latching Switches Only, Default) .....</b>	<b>8</b>
<b>Local Control Operation .....</b>	<b>9</b>
Latching Switch (Default) .....	9
Single Momentary Switch .....	9
Dual Momentary Switch .....	9
<b>Adjust Local Settings .....</b>	<b>10</b>
Local On-Level .....	10
Local Ramp Rate .....	10
Resume Dim .....	11
Change LED Brightness (or turn it off) .....	11
Error Blink .....	12
Blink on Traffic .....	12
Beep on Button Press .....	12
Programming Lock .....	12
<b>INSTEON Setup .....</b>	<b>12</b>
INSTEON Controllers, Responders and Links .....	12
Configure INSTEON Settings .....	13
Make Micro Module a Responder (Set button) .....	13
Make Micro Module a Responder (Switch) .....	13
Make Micro Module a Controller (Set button) .....	13
Make Micro Module a Controller (Switch) .....	14
Groups .....	14
Scenes .....	14
Make Micro Module a Controller of Multiple Responders .....	15
Remove Micro Module as a Controller .....	15
Remove Micro Module as a Responder .....	15
Remove Micro Module as a Controller of Multiple Responders .....	15
Factory Reset .....	16
<b>X10 Setup .....</b>	<b>16</b>
Add X10 Address .....	16
Remove X10 Address .....	16
<b>Specifications .....</b>	<b>17</b>
<b>Troubleshooting .....</b>	<b>20</b>
Stuck/Disabled Buttons .....	22
Phase Bridge Detect Beacon/RF Range Test .....	22
<b>Certification and Warranty .....</b>	<b>23</b>
Certification .....	23
FCC and Industry Canada Compliance Statement .....	23
Declaration of Conformity .....	23
ETL/UL Warning (Safety Warning) .....	23

*Limited Warranty* ..... 23  
*Limitations*..... 24

## About Micro Dimmer

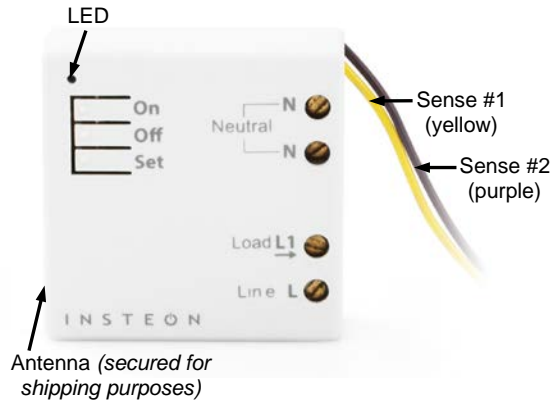

## Features and Benefits

- Integrated dimmer featuring 32 dim levels and 32 ramp rates
- Wires in behind existing wall switch or in fixture box (requires neutral wire)
- Compatible with latching, single momentary and dual momentary switches
- Sense wires allow local control from any standard wall switch
- Can contain up to 400 controller/responder links
- X10 compatible
- All settings preserved in non-volatile memory, even through power failures
- Beeper for easy setup assistance; can also function as a chime module
- Local programming lockout available via software
- 2-year warranty

In the Box	Tools Needed	Optional Accessories
Micro Dimmer	Slotted screwdriver	Mini Remote
Quick Start Guide	Phillips screwdriver	INSTEON Hub
	Wire cutter/stripper	
	Voltage meter	

## Before Installation

### CAUTIONS AND WARNINGS

Read and understand these instructions before installing and retain them for future reference.

This product is intended for installation in accordance with the National Electric Code and local regulations in the United States or the Canadian Electrical Code and local regulations in Canada. Use indoors only.

This product is not designed or approved for use on power lines other than 100-240VAC, 50Hz or 60Hz, single phase. Attempting to use this product on non-approved power lines may have hazardous consequences.

- Use only indoors or in outdoor rated box
- Be sure that you have turned off the circuit breaker or removed the fuse for the circuit you are installing this product into. Installing this product with the power on will expose you to dangerous voltages.
- Connect using only copper or copper-clad wire
- This product may feel warm during operation. The amount of heat generated is within approved limits and poses no hazards. To minimize heat buildup, ensure the area surrounding this product is as clear of clutter as possible.
- Each INSTEON product is assigned a unique INSTEON I.D., which is printed on the product's label.
- To reduce the risk of overheating and possible damage to other equipment, do not use this product to control loads in excess of the specified maximum(s) or, install in locations with electricity specifications which are outside of the product's

specifications. If this device supports dimming, please note that dimming an inductive load, such as a fan or transformer, could cause damage to the dimmer, the load bearing device, or both. If the manufacturer of the load device does not recommend dimming, use a non-dimming INSTEON on/off switch. USER ASSUMES ALL RISKS ASSOCIATED WITH DIMMING AN INDUCTIVE LOAD.

#### Identifying the Electrical Wires in Your Home (North America only)

- Line: usually black (may also be called hot, live or power), carries 120VAC electricity into the wall box
- Neutral: usually white or white wire bundle, commonly daisy-chained from box to box
- Load: usually black, from a separate cable jacket
- Ground: bare copper wire or metal fixture (if grounded)

#### Identifying the Electrical Wires in Your Home (Europe/Australia/New Zealand)

- As wire colors vary from country to country, make sure you always check your electrical wires with a voltage meter to correctly identify line, load, neutral and ground wires
- If you have any questions, consult an electrician or your electricity supplier to learn more about your country's wiring colors and labels

#### **IMPORTANT!**

If you have any difficulties or questions, consult an electrician. If you are not knowledgeable about, and comfortable with, electrical circuitry, you should have a qualified electrician install the product for you.

### *Identify Switch Type*

Before you install Micro module behind a switch, you must determine which switch operation mode applies to your switch—latching, single momentary or dual momentary—as each is wired differently:

- **Latching (default mode):** Switch has no central position. It can be tapped on both the top and bottom and remains in that state once released.
- **Single momentary:** Switch can only be tapped in one location. It returns to central position once released.
- **Dual momentary:** Switch can be tapped on both the top and bottom. It returns to central position once released.

*Note: If you are installing Micro module in a fixture box, switch operation mode does not apply.*

## Installation

- 1) Write down the INSTEON ID found on the back of the unit (XX.XX.XX)
- 2) Turn off breaker/fuse and verify that the power is off
- 3) Disconnect wires from existing switch, fixture or outlet and prep all wires to be connected to Micro module, with 3/16" (5mm) of bare wire on the ends
- 4) Connect wires per diagram which corresponds to your installation

Note: sense lines carry very low current (~0.35mA 240V, ~0.17mA for 120V)

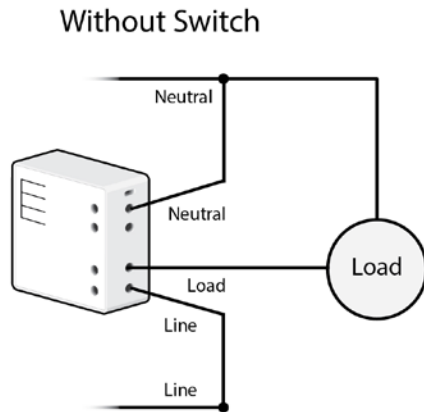

Note: cap the unused sense wires

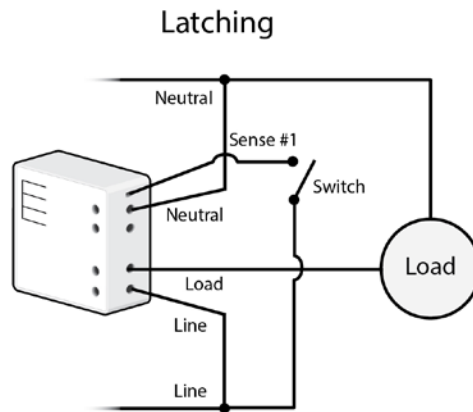

Note: cap the unused Sense #2 wire

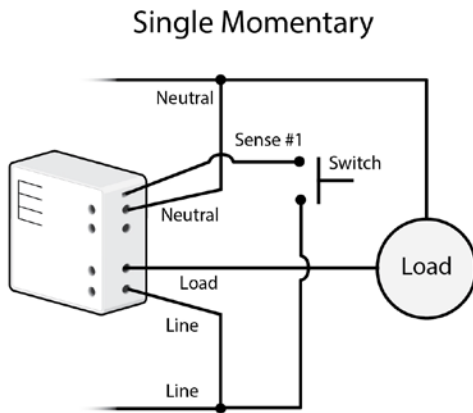

Note: cap the unused Sense #2 wire

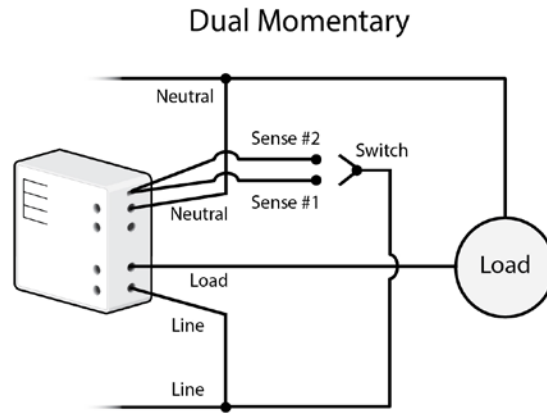

- 5) After ensuring wires are firmly connected and that there is no exposed wire, turn on breaker/fuse  
*After a few seconds, load will turn on (if wired into switch or fixture) and Micro module LED will turn green*
- 6) Test by tapping Micro module on/off buttons  
*Load will turn on and off*  
*Micro Module LED will turn green when load is on and red when load is off*
- 7) If installing a single momentary or dual momentary switch
  - a) Press and hold set button until it beeps

- LED will start blinking green*
- b) Press and hold set button until it beeps a second time  
*LED will start blinking red*
- c) Press and hold set button until it beeps a third time  
*LED will start blinking green*
- d) Perform the step that applies
  - For single momentary: slowly tap set button four times  
*LED will continue blinking green*
  - For dual momentary: slowly tap set button five times  
*LED will start double-blinking green*
  - To switch back to latching: slowly tap set button six times  
*LED will start blinking green*
- e) Once the mode is selected, press and hold set button until it double-beeps  
*LED will stop blinking and turn green if load is on or red if load is off*

## Switch Operation Mode

By default, Micro module is programmed for a latching switch. Program the switch operation for single momentary mode, dual momentary mode or back to latching mode according to your switch type. These settings can also be configured remotely via software (sold separately).

To determine Micro module's current switch operation mode, simply tap set button:

- If it beeps, Micro module is configured for a single momentary switch
- If it double-beeps, Micro module is configured for a dual momentary switch
- If it triple-beeps, Micro module is configured for a latching switch (default)

### Change to Single Momentary Mode

- 1) Press and hold set button until it beeps  
*LED will start blinking green*
- 2) Press and hold set button until it beeps a second time  
*LED will start blinking red*
- 3) Press and hold set button until it beeps a third time  
*LED will start blinking green*
- 4) Slowly tap set button four times  
*LED will continue blinking green*
- 5) Press and hold set button until it double-beeps  
*LED will stop blinking*
- 6) Test mode change by tapping switch on and off  
*Load will respond appropriately*

### Change to Dual Momentary Mode

- 1) Press and hold set button until it beeps  
*LED will start blinking green*
- 2) Press and hold set button until it beeps a second time  
*LED will start blinking red*
- 3) Press and hold set button until it beeps a third time  
*LED will start blinking green*
- 4) Slowly tap set button five times  
*LED will start double-blinking green*
- 5) Press and hold set button until it double-beeps  
*LED will stop blinking*
- 6) Test mode change by tapping switch top and bottom  
*Load will respond appropriately*

### Change to Latching Mode (default)

- 1) Press and hold set button until it beeps  
*LED will start blinking green*
- 2) Press and hold set button until it beeps a second time  
*LED will start blinking red*
- 3) Press and hold set button until it beeps a third time  
*LED will start blinking green*
- 4) Slowly tap set button six times  
*LED will continue blinking green*
- 5) Press and hold set button until it double-beeps  
*LED will stop blinking*
- 6) Test mode change by tapping switch on and off  
*Load will respond appropriately*

### 3-Way Toggle Mode (Latching Switches Only, Default)

Because Micro module comes programmed for latching switches, 3-way toggle mode is enabled by default. Normally, a latching switch reads the switch's up position as on and down position as off. For example, if you turn Micro module on from the latching switch and off from another controller, the switch is still in the up (on) position; turning Micro module back on from the switch would require you to tap the switch down, then up again.

The 3-way toggle mode overrides this sense feature, so in that same scenario—turning Micro module on at the switch and off from another controller, so switch is in up (on) position—you could then turn Micro module on at the switch by tapping it down.

If you are installing Micro module behind a single or dual momentary switch, 3-way toggle mode is ignored. If desired, you can disable (or re-enable) 3-way toggle mode by following these instructions:

- 1) Press and hold set button until it beeps  
*LED will start blinking green*
- 2) Press and hold set button until it beeps a second time  
*LED will start blinking red*
- 3) Press and hold set button until it beeps a third time  
*LED will start blinking green*
- 4) Press and hold set button until it beeps a fourth time  
*LED will start blinking red*
- 5) Slowly tap set button 4 times  
*Micro module will beep*  
*LED will continue blinking red*
- 6) Press and hold set button until it double-beeps  
*LED will stop blinking*  
*3-way toggle mode is now disabled (or re-enabled)*



## Local Control Operation

Micro module's [switch operation mode](#) affects how it responds to commands from the switch. This is why it's important to program Micro module for the specific type of switch you are using. Micro module's on/off buttons function exactly like the top and bottom of your wall switch.

### Latching Switch (Default)

Note that this table refers to the latching switch operation if [3-way toggle mode](#) is disabled (it is enabled by default).

Connected load/responders		
Latching switch	Tap	LED
Top	<b>On</b> (ramped)	<b>Green</b>
Bottom	<b>Off</b> (ramped)	<b>Red</b>

### Single Momentary Switch

Connected load/responders				
Single momentary switch	Tap	Press and hold	Double-tap	LED
Switch	<b>On/Off</b> (ramped)	<b>Brighten/Dim</b> until release or full-on/off ( <i>dimnable responders only</i> )	<b>On/Off</b> (instant)	<b>Green/ Red</b>

### Dual Momentary Switch

Connected load/responders				
Dual momentary switch	Tap	Press and hold	Double-tap	LED
Top	<b>On</b> (ramped)	<b>Brighten</b> until release or 100% ( <i>dimnable responders only</i> )	<b>On</b> (instant)	<b>Green</b>
Bottom	<b>Off</b> (ramped)	<b>Dim</b> until release or off ( <i>dimnable responders only</i> )	<b>Off</b> (instant)	<b>Red</b>

# Adjust Local Settings

## Local On-Level

The local on-level is the brightness at which the connected load will come on when turned on at the switch wired into Micro module. The default on-level is 100% brightness, but it can be set to any one of 32 fixed brightness levels (3% to 100%) or “resume dim” (brightness prior to last being turned off).

- 1) Press and hold set button until it beeps  
*LED will start blinking green*
- 2) Press and hold set button until it beeps a second time  
*LED will start blinking red*
- 3) Press and hold set button until it beeps a third time  
*LED will start blinking green*
- 4) Press and hold set button until it beeps a fourth time  
*LED will start blinking red*
- 5) Tap set button  
*LED will start double-blinking red*
- 6) Use Micro module on/off buttons to adjust load to desired brightness
- 7) Press and hold set button until it double-beeps  
*LED will stop blinking and turn on green*
- 8) Test by turning off and then back on via the paddle  
*Light will turn on at new local on-level*

## Local Ramp Rate

The local ramp rate is the time it takes for the connected light to reach 100% brightness from full-off. The default local ramp rate is 0.5 seconds, but it can be adjusted from instant-on to 5 seconds (using set button) or up to 8 minutes (with software).

*Note: If your local on-level is set to a brightness level that is less than 100%, the ramp rate will be faster than programmed. For example, if your light has a 50% local on-level and a ramp rate of 2 seconds, it will take 1 second for it to ramp from full-off to the local on-level.*

- 1) Press and hold set button until it beeps  
*LED will start blinking green*
- 2) Press and hold set button until it beeps a second time  
*LED will start blinking red*
- 3) Press and hold set button until it beeps a third time  
*LED will start blinking green*
- 4) Press and hold set button until it beeps a fourth time  
*LED will start blinking red*
- 5) Slowly tap set button 2 times  
*LED will continue blinking red*
- 6) Press and hold set button to see the next selected ramp rate  
*Load will ramp from off to on at the next available ramp rate*  
*LED will continue blinking red*
- 7) If this is the desired ramp rate, tap set button to accept  
*Micro module will double beep and LED will stop blinking*
- 8) To see the next ramp rate, press and hold set button again  
*Load will ramp from off to on at the next available ramp rate*

Ramp Rate Presets
"Instant"
0.5 seconds (factory default)
2 seconds
5 seconds

- Test by turning off and then back on via the local switch  
*Light will ramp off and back on at the new local ramp rate*

### Resume Dim

When resume dim is enabled, each time you turn on Micro module it will go to the previously used dim level. By default, Micro module will come on at 100% brightness, but to change the desired level, simply follow the instructions below. The next time you turn Micro module off and on again, it will return to the last used dim level.

- Press and hold set button until it beeps  
*LED will start blinking green*
- Press and hold set button until it beeps a second time  
*LED will start blinking red*
- Press and hold set button until it beeps a third time  
*LED will start blinking green*
- Press and hold set button until it beeps a fourth time  
*LED will start blinking red*
- Slowly tap set button three times  
*LED will start double-blinking red*
- Press and hold set button until it double-beeps  
*LED will stop blinking*
- Test by turning off and then back on via the local switch  
*Light will ramp off and back on to resume dim level.*

### Change LED Brightness (or turn it off)

Default = 50% brightness level

- Press and hold set button until it beeps  
*LED will start blinking green*
- Press and hold set button until it beeps a second time  
*LED will start blinking red*
- Press and hold set button until it beeps a third time  
*LED will start blinking green*
- Tap set button once  
*LED will start double-blinking green*
- Press and hold set button until it beeps  
*LED will turn green (at brightness of connected load)*
- Press and hold Micro module on/off buttons to brighten or dim LED to desired brightness
- Tap set button  
*Micro Module will double-beep and return to ready mode*

## Error Blink

Default = enabled

This setting is only adjustable via software or a central controller. Micro module LED will blink red once for a few seconds if one or more responders do not acknowledge a message and will blink green once if all responders are successful.

## Blink on Traffic

Default = disabled

This setting is only adjustable via software or a central controller. Micro module LED will blink red if it detects noise that could disrupt communication.

## Beep on Button Press

Default = disabled

This setting is only adjustable via software or a central controller. Micro module will beep every time its connected switch is tapped or a button is pressed.

## Programming Lock

Default = disabled

This setting is only adjustable via software or a central controller. When enabled, Programming Lock will disable the set button so that a user can not adjust settings or modify links. This is typically used in commercial or installer applications.

## INSTEON Setup

Some products have subtle differences in their setup procedures. Please refer to the other devices' owner's manuals for details.

### INSTEON Controllers, Responders and Links

- The INSTEON “transmitter” is called a **controller**
- The INSTEON “receiver” is called a **responder**
- The association between the controller and responder is called a **link**

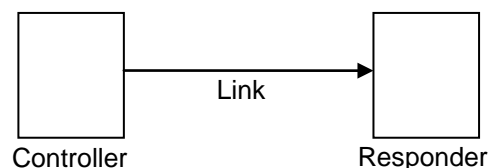

Note that a link is one way. If you wish to have control “the other way,” simply add a link “the other way.”

## Configure INSTEON Settings

Most Micro module links and settings can be configured locally—during installation with the module's set button or after installation using the switch connected to the module.

All Micro module settings can be managed remotely via software (sold separately).

### Make Micro Module a Responder (Set button)

*Note: you must perform these steps before reinstalling the wall switch or fixture.*

- 1) Press and hold controller set button until it beeps  
*Controller LED will start blinking*  
*You will have four minutes to complete the next steps before linking mode times out*
- 2) Adjust load connected to Micro module to desired brightness level (even off)
- 3) Press and hold Micro module set button until it double-beeps  
*Controller will double-beep and its LED will stop blinking*
- 4) Test link by tapping controller button on and off or pressing and holding to brighten/dim  
*Load connected to Micro module will respond appropriately*

### Make Micro Module a Responder (Switch)

- 1) Press and hold controller set button until it beeps  
*Controller LED will start blinking*  
*You will have four minutes to complete the next steps before linking mode times out*
- 2) Adjust load connected to Micro module to desired brightness level (on or off)
- 3) Quickly tap switch connected to Micro module exactly five times in less than four seconds. (If using a latching or dual momentary switch, alternate switch directions: up-down-up-down-up or down-up-down-up-down.) After tapping switch, wait two seconds.  
*Micro module will double-beep*  
*Controller will double-beep and its LED will stop blinking*
- 4) Test link by tapping controller button on and off  
*Load connected to Micro module will turn on and off*

### Make Micro Module a Controller (Set button)

*Note: you must perform these steps before reinstalling the wall switch or fixture.*

- 1) Press and hold Micro module set button until it beeps  
*Micro module LED will start blinking green*  
*You will have four minutes to complete the next steps before linking mode times out*
- 2) Adjust responder to desired state<sup>1</sup>
- 3) Press and hold responder set button until it double-beeps  
*Micro module will double-beep and its LED will stop blinking<sup>2</sup>*
- 4) Test link by tapping or pressing and holding Micro module on/off buttons to turn on/off or brighten/dim  
*Responder will respond appropriately*

<sup>1</sup> If responder is a multi-scene device such as a KeypadLinc, tap scene button you wish to control until the LED is in the desired scene state (on or off).

<sup>2</sup> If either controller or responder LED continues blinking, the addition failed. Tap device's set button until LED stops blinking and try linking again.

## Make Micro Module a Controller (Switch)

- 1) Quickly tap switch connected to Micro module exactly five times in less than four seconds. (If using a latching or dual momentary switch, alternate switch directions: up-down-up-down-up or down-up-down-up-down.) After tapping switch, wait two seconds.

*Micro module will beep to indicate it has entered linking mode*

*You will have four minutes to complete the next steps before linking mode times out*

- 2) Adjust responder to desired state<sup>1</sup>
- 3) Press and hold responder set button until it double-beeps

*Micro module will double-beep and its LED will stop blinking*

- 4) Test link by tapping switch connected to Micro module to turn on/off or brighten/dim

*Responder will respond appropriately*

## Groups

Devices in a group share all the same settings (e.g., on-level, ramp rate). This keeps all group members synchronized. Every device in a group is both a controller of, and responder to, all the other devices. The most common example of a group is a 3-way lighting circuit (2 switches). For simplicity, we will assume that the desired group level is on.

The following steps will create a virtual 3-way circuit including device “A” and device “B”:

- 1) Turn A and B on
- 2) Press and hold A set button until it beeps  
*A status LED will start blinking green*
- 3) Press and hold B set button until it double-beeps  
*A will double-beep and its LED will stop blinking*
- 4) Press and hold B set button until it beeps  
*B LED will start blinking green*
- 5) Press and hold A set button until it double-beeps  
*B will double-beep and its LED will stop blinking*
- 6) Test by turning load on and off from A and then B  
*The load(s) and both A and B LEDs will remain in synch*

## Scenes

Devices in a scene can each have different settings. This provides for advanced scene creation. Software is recommended for scene management.

Example of a scene with 1 controller and Micro module as a member:

- 1) Press and hold controller button until it beeps  
*Controller LED will start blinking green*
- 2) Tap controller set button  
*Controller LED will start double-blinking green*
- 3) Adjust load connected to Micro module to desired brightness level
- 4) Press and hold Micro module set button until it double-beeps
- 5) For each additional scene member:
  - a. Adjust member to desired scene state
  - b. Press and hold set button until it double-beeps
- 6) Tap controller set button  
*Controller will beep and LED will stop blinking*
- 7) Test by tapping controller button on and off  
*Micro module and other scene responders will all respond appropriately*

<sup>1</sup> If responder is a multi-scene device such as a KeypadLinc, tap scene button you wish to control until the LED is in the desired scene state (on or off)

### **Make Micro Module a Controller of Multiple Responders**

- 1) Press and hold Micro module set button until it beeps  
*LED will start blinking green*
- 2) Tap Micro module set button  
*LED will start double-blinking green*
- 3) For each responder you are adding:
  - a. Adjust responder to desired scene brightness/state
  - b. Press and hold set button until it double-beeps
- 4) Tap Micro module set button  
*Micro module will beep and LED will stop blinking*
- 5) Test by tapping switch wired into Micro module on and off  
*All the responders will turn on and off*

### **Remove Micro Module as a Controller**

If you no longer want Micro module to control another device (or are removing Micro module from your network) it is important that you follow the instructions below for each responder.

- 1) Press and hold Micro module set button until it beeps  
*LED will start blinking green*
- 2) Press and hold Micro module set button until it beeps a second time  
*LED will start blinking red*
- 3) Press and hold responder set button until it double-beeps  
*Micro module will double-beep and LED will stop blinking*
- 4) Test by tapping Micro module on and off  
*Former responder will not respond*

### **Remove Micro Module as a Responder**

If you no longer want a controller button to control Micro module, follow these directions.

*Note: If you ever wish to uninstall Micro module, it is important that you remove all Micro module responder links. Otherwise, controllers will repetitively retry commands, creating network delays.*

- 1) Press and hold controller button until it beeps  
*LED will start blinking green*
- 2) Press and hold controller button until it beeps a second time  
*LED will start blinking red*
- 3) Press and hold Micro module set button until it double-beeps  
*Controller LED will stop blinking*
- 4) Test by tapping controller button on and off  
*Micro module will no longer respond*

### **Remove Micro Module as a Controller of Multiple Responders**

- 1) Press and hold Micro module set button until it beeps  
*LED will start blinking green*
- 2) Press and hold Micro module set button until it beeps a second time  
*LED will start blinking red*
- 3) Tap Micro module set button  
*LED will start double-blinking red*
- 4) For each responder you are removing:
  - a. Press and hold set button until it double-beeps
- 5) Tap Micro module set button

- Micro module will beep and LED will stop blinking*
- 6) Test by tapping the switch wired into Micro module on and off  
*None of the former responders will respond*

## Factory Reset

All settings and scenes will be erased and return to factory default settings.

- 1) Press and hold Micro module set button until it beeps  
*LED will start blinking green*
- 2) Press and hold Micro module set button until it beeps a second time  
*LED will start blinking red*
- 3) Press and hold Micro module set button until it beeps a third time  
*LED will start blinking green*
- 4) Slowly tap Micro module set button 3 times  
*LED will start double-blinking green*
- 5) Press and hold Micro module set button. Do not let go.  
*Micro module will begin to emit a long beep*
- 6) After beep stops, release Micro module set button  
*After a few seconds, the LED will flash white*  
*Micro module will double-beep and the load will turn on*

## X10 Setup

Micro module ships with no X10 address assigned.

### Add X10 Address

- 1) Press and hold set button until it beeps  
*LED will start blinking green*
- 2) Send the X10 address 3 times (with or without commands)  
*Example: A1-AON-A1-AON-A1-AON or A1-A1-A1-AON*  
*Micro module will double-beep and LED will stop blinking*
- 3) Test by sending X10 on and off commands  
*Load will turn on and off*

### Remove X10 Address

- 1) Press and hold set button until it beeps  
*LED will start blinking green*
- 2) Press and hold set button until it beeps a second time  
*LED will start blinking red*
- 3) Send the X10 address 3 times (with or without commands)  
*Example: A1-AOFF-A1-AOFF-A1-AOFF or A1-A1-A1-AOFF*  
*Micro module will double-beep and LED will stop blinking*
- 4) Test by sending X10 on and off commands  
*Micro module will not respond*



## Specifications

General		
Product name	Micro Dimmer	
Brand/manufacturer	INSTEON	
Manufacturer product number	US	2442-222
	EU	2442-422
	AUS/NZ	2442-522
UPC	US	813922012705
	EU	813922012712
	AUS/NZ	813922012729
Warranty	2 years, limited	
INSTEON		
INSTEON	Controller and responder	
Maximum links/scenes	400	
Load brightness levels	32 locally (256 with software)	
Status LED	Green when load is on, red when load is off	
	Blinks red once when responder does not acknowledge/blinks green once if all responders acknowledge (can be disabled via software)	
	Blinks red or green during setup	
	Blinks to indicate traffic (must be enabled via software)	
Beep on button press	Beeps when button is pressed or connected switch is tapped (must be enabled via software)	
LED brightness	Adjustable, from off to bright	
Local on-level	Adjustable, 32 fixed brightness levels or resume dim	
Local ramp-rate	Adjustable from 0.1 seconds to 5 seconds locally (0.1 seconds to 8 minutes via software)	
Local control	Yes	
Commands supported as controller	On	Off
	Fast-on	Fast-off
	Begin brighten	Begin dim
	End brighten	End dim
Commands Supported as responder	On	Off
	Fast-on	Fast-off
	Begin brighten	Begin dim
	End brighten	End dim
	Incremental brighten	Incremental dim
	Beep	
Software Configurable	Yes	

RF Range	Up to 50 meters (150 feet) open air* <i>*Range may vary due to local interference/building construction</i>	
Phase detect beacon	Yes	
INSTEON Device Category	0x01 Dimmable Lighting Control (All Frequencies)	
INSTEON Device Subcategory	2442-222 (915 MHz)	0x35
	2442-422 (869 MHz)	0x38
	2442-522 (921 MHz)	0x39
<b>X10</b>		
X10 address	1 optional (comes unassigned)	
X10 transmitter	Yes	
X10 receiver	Yes	
X10 status response	Supported	
X10 resume dim	Supported (by setting local on-level to zero)	
X10 minimum transmit level	3.2 Vpp into 5 Ohms	
X10 minimum receive level	20mV into 5 Ohms	
X10 messages repeated	No	
<b>Mechanical</b>		
Mounting	Behind switch or above light fixture in a single-gang electrical box	
Wires	Sense 1 (yellow wire), 0.205mm <sup>2</sup> / 24 AWG	
	Sense 2 (purple wire), 0.205mm <sup>2</sup> / 24 AWG	
Max Cable Size	4mm <sup>2</sup> (2.72mm diameter) / 12 AWG	
Min Cable Size	1.5mm <sup>2</sup> / 15 AWG	
Screw Clamp Connections	Line	
	Load	
	Neutral 1	
	Neutral 2	
Case Color	White	
Set button	Yes	
Plastic	UV stabilized ABS+PC	
Beeper	Yes	
LED	1, RGB	
Dimensions	46.6mm H x 46.6mm W x 17.5mm D (1.8" H x 1.8" W x 0.7" D)	
Weight	71.5g (2.5 oz)	
Operating Environment	Indoors	
Operating Temperature Range	32° to 104° F (0° to 40° C)	
Operating Humidity Range	0-90% relative humidity	

Storage temperature range	-4° to 158° F (-20° to 70° C)
<b>Electrical</b>	
Voltage	100VAC to 240VAC
Frequency	50/60Hz auto-detected at power-up
Maximum load	200 Watts (@ 240VAC) 200 Watts (@ 120VAC)
Minimum load	5 Watts
Load type(s)	Incandescent
Hardwired remote control	Yes, either latching or momentary switches supported
Retains all settings without power	Yes, saved in non-volatile EEPROM
Standby power consumption	< 1 watt
Safety approved	ETL, CE, C-Tick
Certifications	FCC 15.107, 15.109, 15.249 RSS 210 EN 300 220-2, 301 489-3 AS/NZS 4268, CISPR 22 UL 1472 IEC 60669-2-1
FCC ID	SBPMM01

All product specifications are subject to change.

## Troubleshooting

Problem	Possible Cause	Solution
The LEDs on Micro module are not turning on at all	Micro module is not getting power	Make sure the circuit breaker is turned on
		Check junction box wires to ensure all connections are tight and no bare wires are exposed
		Check the light fixture to ensure all connections are tight and no bare wires are exposed
The switch I'm replacing only has two wires	Micro module needs a neutral wire in order to operate	Look in the rear of the junction box for a group of wires tied together with a wire nut. Those are commonly neutral wires.
		Pull a neutral from nearby junction box
Micro module is not receiving signals from INSTEON or X10 controllers	The controller is plugged into a power strip	Powerline signals can't travel through some power filters. Plug controller into wall outlet.
	Other modules are attenuating the signal or causing noise on the line	Plug other modules into a signal filter or move the modules or controller to another outlet
		INSTEON devices act as network repeaters. Add new or move existing INSTEON devices and retest.
	Micro module and the controller are on opposite powerline phases	Make sure there are at least 2 dual-band INSTEON products are properly installed to bridge the phases
The light turned on by itself	Another controller, a timer, or stray X10 signals triggered Micro module	Install a power line signal blocker in your home to keep X10 signals from neighboring homes from interfering. Consider not using Micro module in X10 mode.
	Micro module may have an undesired responder membership	Use software to remove membership or perform a factory reset and re-setup Micro module
The controlled light does not appear to turn on or off right away	Responder's scene ramp rate might be quite slow	Set a faster ramp rate and relink responder
Micro module responds to on commands but not off commands	Load connected to Micro module is producing electrical noise that is interfering with the Micro module reception of powerline signal	Install an inline signal filter between the load and Micro module
		Install additional INSTEON devices to boost the INSTEON signal
I can't turn Micro module on (but I can turn it off, brighten and dim it)	The on-level may be set to fully-off or very dim	Set a brighter on-level. See <a href="#">Local On-Level</a> .
When I try to turn on my	Micro module may be set up	Remove the X10 address from Micro module

light with another controller, the light will turn on, then back off	with an INSTEON on-level at a high brightness and an X10 address on-level at a low brightness	Remove the X10 address from INSTEON controller
When I press a button on Micro module, it takes a long time for other INSTEON devices it is controlling to respond	Micro module is trying to control a responder that is not responding and may have been removed	Connect power to the responder
		If the INSTEON device is still available, remove it from Micro module and then re-add it
		Perform a factory reset
The load is buzzing when on or dim.	The dimming component inside Micro module “chops” the power line sine wave to reduce the power	The bulb filaments are vibrating. Use rough-service, or appliance grade bulbs to reduce the noise
		Run Micro module in the “full-on” mode or switch to a non-dimming Micro On/Off module
Micro module is locked up	A surge or excessive noise on the power line occurred	Power cycle Micro module
		Perform a factory reset
Micro module is getting warm to the touch	It is normal for dimmers to get warm (Micro module conforms to safety standards)	Micro module will dissipate about 1 watt per 100 watts of load. Using metal junction boxes, removing insulation around the outside of the box and controlling a smaller load will all help lower the temperature.
Micro module blinks green one time after it is activated	Micro module supports an error blink feature. A green blink indicates that all responders are communicating properly	You may disable error blink via software if desired
Micro module blinks red one time after it is activated	Micro module supports an error blink to let you know that a responder did not acknowledge the command and that there is a lot of unacknowledged communications on the network	Confirm that the responder is powered and available. If you don't want this device to be a responder you can unlink it if available or use software to remove the link. Once the issue is resolved, you may disable error blink via software if desired.
Micro module can turn off my responder, but nothing happens when I send an on	Responder's scene level is off	Add responder to scene again at desired scene on-level
Micro module still controls devices even after factory reset	The responder's link was not removed prior to Micro module factory reset (called a half-link)	Remove responder from Micro module

## Stuck/Disabled Buttons

If Micro module's buttons are not responding, they may have been disabled due to a stuck button. If any button is pressed during power-up, or after power-up any Micro module button is pressed for about four minutes, Micro module engages stuck button mode and automatically disables all button actions. All buttons will remain disabled until next power cycle.

To re-enable buttons, ensure buttons are not being pressed, turn off breaker supplying power to Micro module and turn it back on. Micro module buttons should function again. Additionally, check Micro module's installation location for any obstacles that could be pressing the buttons on Micro module's face and causing stuck button mode.

## Phase Bridge Detect Beacon/RF Range Test

Micro module automatically bridges the electrical phases in your home (via communications with other dual-band devices on the "other phase"). This is only important in 2-phase homes with powerline-only INSTEON products or buildings with both 2- and 3- phase circuits. The phase bridge detect beacon can also be used as an RF range test to see if your devices are within communication range. You will need at least one other INSTEON dual-band device installed.

- 1) Press and hold set button until it beeps  
*LED will start blinking green*
- 2) Press and hold set button until it beeps a second time  
*LED will start blinking red*
- 3) Press and hold set button until it beeps a third time  
*LED will start blinking green*
- 4) Slowly tap set button 2 times  
*LED will continue blinking green*
- 5) Press and hold set button until it beeps  
*Micro module will start beeping once per second*  
*LED will turn solid green*
- 6) Check the LED behavior of other dual-band devices  
Phase Bridge Detect Beacon
  - If the other dual-band device is blinking green, it is on the other phase:  
*Device provides a phase bridge to Micro module*
  - If the other dual-band device is blinking red, it is on the same phase:  
*Device does not provide a phase bridge to Micro module*  
*Relocate if necessary (and practical)*
  - If the other dual-band device is not blinking:  
*Device is not within RF range of Micro module so it does not provide a phase bridge*  
*Relocate if necessary (and practical) or add an additional dual-band device*RF Range Test
  - If LED is blinking:  
*Device is within RF communication range*
  - If LED is not blinking:  
*Device is not within RF communication range*  
*Relocate if necessary (and practical) or add an additional dual-band device*
- 7) Tap set button  
*Micro module will stop beeping*  
*Other device LEDs will stop blinking*

If you have tried these solutions, reviewed the owner's manual, and still cannot resolve the issue you are having visit <http://www.insteon.com/support> or call INSTEON Support Line at 866-243-8022.

# Certification and Warranty

## Certification

This product has been thoroughly tested by ITS ETL SEMKO, a nationally recognized independent third-party testing laboratory. The North American ETL Listed mark signifies that the device has been tested to and has met the requirements of a widely recognized consensus of U.S. and Canadian device safety standards, that the manufacturing site has been audited, and that the manufacturer has agreed to a program of quarterly factory follow-up inspections to verify continued conformance.

## FCC and Industry Canada Compliance Statement

This device complies with FCC Rules Part 15 and Industry Canada RSS-210 (Rev. 7). Operation is subject to the following two conditions:

- (1) This device may not cause harmful interference, and
- (2) This device must accept any interference, including interference that may cause undesired operation of the device.

Le présent appareil est conforme aux CNR d'Industrie Canada applicables aux appareils radio exempts de licence. L'exploitation est autorisée aux deux conditions suivantes:

- (1) l'appareil ne doit pas produire de brouillage, et
- (2) l'utilisateur de l'appareil doit accepter tout brouillage radioélectrique subi, même si le brouillage est susceptible d'en compromettre le fonctionnement.

The digital circuitry of this device has been tested and found to comply with the limits for a Class B digital device, pursuant to Part 15 of the FCC Rules. These limits are designed to provide reasonable protection against harmful interference in residential installations. This equipment generates, uses, and can radiate radio frequency energy and, if not installed and used in accordance with the instructions, may cause harmful interference to radio and television reception. However, there is no guarantee that interference will not occur in a particular installation. If this device does cause such interference, which can be verified by turning the device off and on, the user is encouraged to eliminate the interference by one or more of the following measures:

- Re-orient or relocate the receiving antenna of the device experiencing the interference
- Increase the distance between this device and the receiver
- Connect the device to an AC outlet on a circuit different from the one that supplies power to the receiver
- Consult the dealer or an experienced radio/TV technician

WARNING: Changes or modifications to this device not expressly approved by the party responsible for compliance could void the user's authority to operate the equipment.

## Declaration of Conformity

Hereby, INSTEON declares that this device is in compliance with the essential requirements and other relevant provisions of the following Directives:

- 1) Low Voltage Equipment Directive 2006/95/EC
- 2) Electromagnetic Compatibility Directive 2004/108/EC
- 3) Hazardous Substance Directive 2005/95/EC

Technical data and copies of the original Declaration of Conformity are available and can be obtained from INSTEON; 16542 Millikan Ave, Irvine, CA, USA.

User Information for Consumer Products Covered by EU Directive 2002/96/EC on Waste Electric and Electronic Equipment (WEEE)

This document contains important information for users with regards to the proper disposal and recycling of INSTEON products. Consumers are required to comply with this notice for all electronic products bearing the following symbol:



Environmental Information for Customers in the European Union

European Directive 2002/96/EC requires that the equipment bearing this symbol on the product and/or its packaging must not be disposed of with unsorted municipal waste. The symbol indicates that this product should be disposed of separately from regular household waste streams.

It is your responsibility to dispose of this and other electric and electronic equipment via designated collection facilities appointed by the government or local authorities. Correct disposal and recycling will help prevent potential negative consequences to the environment and human health.

For more detailed information about the disposal of your old equipment, please contact your local authorities, waste disposal service, or the shop where you purchased the product.

DECLARATION OF CONFORMITY TO R&TTE DIRECTIVE 1999/5/EC for the European Community, Switzerland, Norway, Iceland and Liechtenstein

Product category: general consumer (category 3).

English: This equipment is in compliance with the essential requirements and other relevant provisions of the European R&TTE Directive 1999/5/EC

Deutsch [German]: Dieses Gerät entspricht den grundlegenden Anforderungen und den weiteren entsprechenden Vorgaben der Richtlinie 1999/5/EC.

Nederlands [Dutch]: Dit apparaat voldoet aan de essentiële eisen en andere van toepassing zijnde bepalingen van de Richtlijn 1999/5/EC.

Svenska [Swedish]: Denna utrustning står i överensstämmelse med de väsentliga egenskapskrav och övriga relevanta bestämmelser som framgår av direktiv 1999/5/EG.

Français [French]: Cet appareil est conforme aux exigences essentielles et aux autres dispositions pertinentes de la Directive 1999/5/EC

Español [Spanish]: Este equipo cumple con los requisitos esenciales así como con otras disposiciones de la Directiva 1999/5/CE.

Português [Portuguese]: Este equipamento está em conformidade com os requisitos essenciais e outras provisões relevantes da Directiva 1999/5/EC.

Italiano [Italian]: Questo apparato è conforme ai requisiti essenziali ed agli altri principi sanciti dalla Direttiva 1999/5/CE.

Norsk [Norwegian]: Dette utstyret er i samsvar med de grunnleggende krav og andre relevante bestemmelser i EU-direktiv 1999/5/EF.

Suomi [Finnish]: Tämä laite täyttää direktiivin 1999/5/EY olennaiset vaatimukset ja on siinä asetettujen muiden laitetta koskevien määräysten mukainen.

Dansk [Danish]: Dette udstyr er i overensstemmelse med de væsentlige krav og andre relevante bestemmelser i Direktiv 1999/5/EF.

Polski [Polish]: Urządzenie jest zgodne z ogólnymi wymaganiami oraz szczególnymi warunkami określonymi Dyrektywą UE: 1999/5/EC

## ETL/UL Warning (Safety Warning)

**CAUTION:** To reduce the risk of overheating and possible damage to other equipment, do not install this device to control a receptacle, a motor-operated appliance, a fluorescent lighting fixture, or a transformer-supplied appliance.

Gradateurs commandant une DIN Raile a filament de tungstène – afin de réduire le risque de surchauffe et la possibilité d'endommagement a d'autres matériels, ne pas installer pour commander une prise, un appareil a moteur, une DIN Raile fluorescente ou un appareil alimente par un transformateur.

## Limited Warranty

Seller warrants to the original consumer purchaser of this product that, for a period of two years from the date of purchase, this product will be free from defects in material and workmanship and will perform in substantial conformity to the description of the product in this Owner's Manual. This warranty shall not apply to defects or errors caused by misuse or neglect. If the product is found to be defective in material or workmanship, or if the product does not perform as warranted above during the warranty period, Seller will either repair it, replace it, or refund the purchase price, at its option, upon receipt of the product at the address below, postage prepaid, with proof of the date of purchase and an explanation of the defect or error. The repair, replacement, or refund that is provided for above shall be the full

extent of Seller's liability with respect to this product. For repair or replacement during the warranty period, call INSTEON at 866-243-8022 with the Model # and Revision # of the device to receive an RMA# and send the product, along with all other required materials to:

**INSTEON**  
**ATTN: Receiving**  
**16542 Millikan Ave.**  
**Irvine, CA 92606-5027**

**Limitations**

The above warranty is in lieu of and Seller disclaims all other warranties, whether oral or written, express or implied, including any warranty or merchantability or fitness for a particular purpose. Any implied warranty, including any warranty of merchantability or fitness for a particular purpose, which may not be disclaimed or supplanted as provided above shall be limited to the two-year of the express warranty above. No other representation or claim of any nature by any person shall be binding upon Seller or modify the terms of the above warranty and disclaimer.

Home automation devices have the risk of failure to operate, incorrect operation, or electrical or mechanical tampering. For optimal use, manually verify the device state. Any home automation device should be viewed as a convenience, but not as a sole method for controlling your home.

In no event shall Seller be liable for special, incidental, consequential, or other damages resulting from possession or use of this device, including without limitation damage to property and, to the extent permitted by law, personal injury, even if Seller knew or should have known of the possibility of such damages. Some states do not allow limitations on how long an implied warranty lasts and/or the exclusion or limitation of damages, in which case the above limitations and/or exclusions may not apply to you. You may also have other legal rights that may vary from state to state.

Protected under U.S and foreign patents (see [www.insteon.com/patents](http://www.insteon.com/patents))

© Copyright 2013 INSTEON, 16542 Millikan Ave., Irvine, CA 92606, 866-243-8022, [www.insteon.com](http://www.insteon.com)