

CHICAGO
Electric® Power Tools

POWDER COATING SYSTEM

Model 42802

SET UP AND OPERATING INSTRUCTIONS



Distributed exclusively by Harbor Freight Tools®.
3491 Mission Oaks Blvd., Camarillo, CA 93011
Visit our website at: <http://www.harborfreight.com>



Read this material before using this product.
Failure to do so can result in serious injury.
SAVE THIS MANUAL.

Copyright© 2000 by Harbor Freight Tools®. All rights reserved. No portion of this manual or any artwork contained herein may be reproduced in any shape or form without the express written consent of Harbor Freight Tools. Diagrams within this manual may not be drawn proportionally. Due to continuing improvements, actual product may differ slightly from the product described herein. Tools required for assembly and service may not be included.

For technical questions or replacement parts, please call 1-800-444-3353.

Manual Revised 09d

SPECIFICATIONS

Power Consumption	120 V~, 60 Hz
Air Supply	20 to 40 PSI, dry air
Air Inlet	1/4 inch NPT thread
Power Cord	16 AWG

Note: Performance of this tool may vary depending on variations in local line voltage. Extension cord usage may also affect tool performance.

Save This Manual

You will need the manual for the safety warnings and precautions, assembly instructions, operating and maintenance procedures, parts list and diagram. Keep your invoice with this manual. Write the invoice number on the inside of the front cover. Keep the manual and invoice in a safe and dry place for future reference.

SAFETY WARNINGS AND PRECAUTIONS

WARNING: When using tool, basic safety precautions should always be followed to reduce the risk of personal injury and damage to equipment.

Read all instructions before using this tool!

1. **Keep work area clean.** Cluttered areas invite injuries.
2. **Observe work area conditions.** Do not use machines or power tools in damp or wet locations. Don't expose to rain. Keep work area well lighted. Do not use electrically powered tools in the presence of flammable gases or liquids.

3. **Keep children away.** Children must never be allowed in the work area. Do not let them handle machines, tools, or extension cords.
4. **Store idle equipment.** When not in use, tools must be stored in a dry location to inhibit rust. Always lock up tools and keep out of reach of children.
5. **Do not force tool.** It will do the job better and more safely at the rate for which it was intended. Do not use inappropriate attachments in an attempt to exceed the tool capacity.
6. **Use the right tool for the job.** Do not attempt to force a small tool or attachment to do the work of a larger industrial tool. There are certain applications for which this tool was designed. Do not modify this tool and do not use this tool for a purpose for which it was not intended.
7. **Dress properly.** Do not wear loose clothing or jewelry as they can be caught in moving parts. Protective, electrically non-conductive clothes and non-skid footwear are recommended when working. Wear restrictive hair covering to contain long hair.
8. **Use eye and ear protection.** Always wear ANSI approved impact safety goggles. Wear a full face shield if you are producing metal filings or wood chips. Wear an ANSI approved dust mask or respirator when working around metal, wood, and chemical dusts and mists.
9. **Do not overreach.** Keep proper footing and balance at all times. Do not reach over or across running machines.

10. **Maintain tools with care.** Keep tools sharp and clean for better and safer performance. Follow instructions for lubricating and changing accessories. Inspect tool cords periodically and, if damaged, have them repaired by an authorized technician. The handles must be kept clean, dry, and free from oil and grease at all times.
11. **Disconnect power.** Unplug transformer when not in use.
12. **Avoid unintentional starting.** Be sure the switch is in the Off position when not in use and before plugging in. Do not carry any tool with your finger on the trigger, whether it is plugged in or not.
13. **Stay alert.** Watch what you are doing, use common sense. Do not operate any tool when you are tired.
14. **Check for damaged parts.** Before using any tool, any part that appears damaged should be carefully checked to determine that it will operate properly and perform its intended function. Check for alignment and binding of moving parts; any broken parts or mounting fixtures; and any other condition that may affect proper operation. Any part that is damaged should be properly repaired or replaced by a qualified technician. Do not use the tool if any switch does not turn On and Off properly.
15. **Guard against electric shock.** Prevent body contact with grounded surfaces such as pipes, radiators, ranges, and refrigerator enclosures. Never touch the object being coated with one hand while spraying with the other.
16. **Replacement parts and accessories.** When servicing, use only identical replacement parts. Use of any other parts will void the warranty. Only use accessories intended for use with this tool. Approved accessories are available from Harbor Freight Tools.
17. **Do not operate tool if under the influence of alcohol or drugs.** Read warning labels on prescriptions to determine if your judgment or reflexes are impaired while taking drugs. If there is any doubt, do not operate the tool.
18. **Use proper size and type extension cord.** If an extension cord is required, it must be of the proper size and type to supply the correct current to the tool without heating up. Otherwise, the extension cord could melt and catch fire, or cause electrical damage to the tool. This tool requires use of an extension cord of **0 to 10 amps** capability (up to 50 feet), with wire size rated at **18 AWG**. Longer extension cords require larger size wire. If you are using the tool outdoors, use an extension cord rated for outdoor use (signified by "WA" on the jacket).
19. **Maintenance.** For your safety, service and maintenance should be performed regularly by a qualified technician.
20. The warnings, cautions, and instructions discussed in this instruction manual cannot cover all possible conditions and situations that may occur. It must be understood by the operator that common sense and caution are factors which cannot be built into this

MAIN COMPONENTS

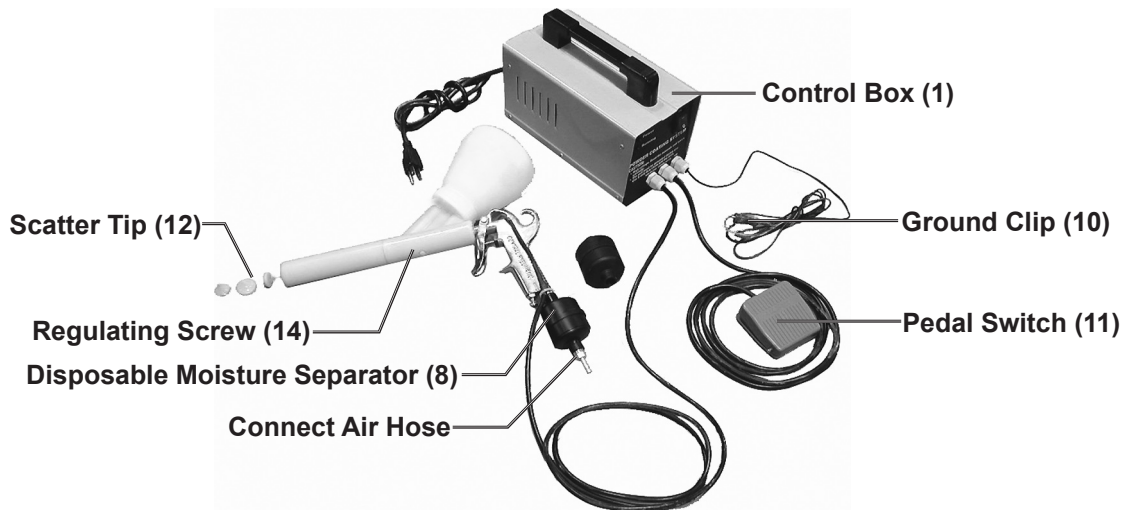

PREPARATION

1. Setup an air supply with an air pressure regulator and moisture trap (do not use an inline air oiler). The air compressor must provide an air pressure of 20 to 40 PSI.
2. Select a safe location for spraying and curing with:
 - adequate lighting
 - active ventilation
 - no flame or ignition source
 - an area dry, clean, and covered -- free of flammable material
3. Have an activated charcoal filter respirator availability for use when curing.
4. Have disposable dust masks available for use when powder spraying.
5. Have a pair of vinyl gloves for use when handling the power and sprayed objects.
6. Use ANSI-approved safety glasses.
7. If using an extension cord, it must have a ground prong.
8. Setup a dedicated electric oven (**with adequate ventilation**) for curing the coated objects with a temperature capability from 300 to 500° F.

WARNING: Never use a gas oven, the fumes from curing can be explosive. Never use a home oven that is also used for food. Contamination of food will occur.

9. Clean the object to be powder coated of any old coatings, rust, grease and oil.

OPERATION

1. Place or hang the cleaned object to be coated near the ventilation system.
If the object has grooves or recesses, position the object so that gravity assists the powder mist to fall into the grooves or recesses.
2. Connect the Disposable Moisture Separator (8) to the Spray Gun (2).

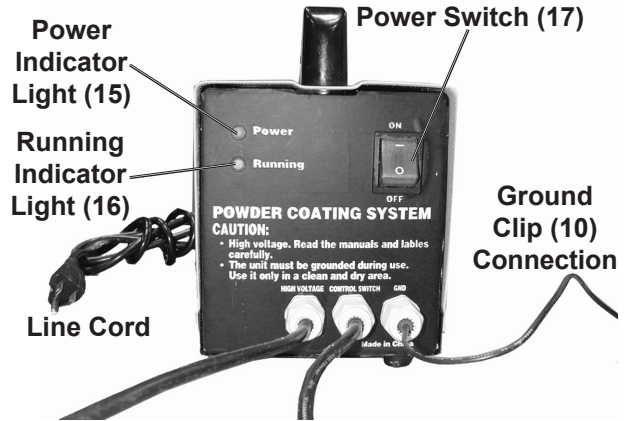
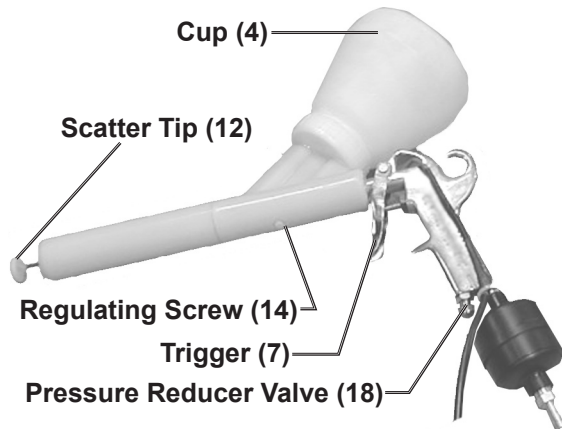

3. Unscrew the Cup (4) from the Spray Gun (2) and fill with up to two inches of coating powder (not supplied).
 - Turn the Cup upside down and place on a clean piece of paper.
 - Put on a pair of disposal vinyl gloves.
 - Open the powder coating container, and using a piece of clean paper as a guide, pour the powder into the Cup.
 - Turn the Spray Gun upside down and screw the Cup back into the Spray Gun.
 - Reseal powder container.

Note: Only use the provided cups with this system. Other cups will not seal properly.

4. Connect the 1/4 inch air hose to the Disposable Moisture Separator (8).
5. Attach the Ground Clip (10) to the metal object being coated. Securely attach the Ground Clip to an area which is not being coated if possible. This connection is absolutely necessary to draw the electrically charged (power) particles to the metal object.

6. Turn ON the Power Switch (17) of the Control Box (1).
7. Turn ON the compressor and adjust the air pressure to between 20 and 40 PSI. This can be done at the compressor if it has a pressure value, or on the Spray Gun by adjusting the Pressure Reducer Valve (18).
8. Press the Spray Gun Trigger (7) and Pedal Switch (11) at the same time and test the spray pattern on a piece of scrap metal. The Trigger controls the air and powder flow. The Pedal Switch controls the electrical charge. If the pattern is too small or too large, change the Scatter Tip (12). Remember that the pointed end of the Scatter Tip faces toward the Spray Gun and screws on. The spray pattern can also be adjusted using the Regulating Screw (14): loosen to expand the pattern, tighten to reduce the pattern size.
9. When coating, keep the Spray Gun approximately eight inches from the metal object.
 - Point the Spray Gun toward the object at different angles to guarantee that all areas are coated.

- When completed, the object should be completely coated with a dull, opaque coat of powder.
10. When finished spraying:
 - remove your foot from the Pedal Switch (11),
 - press the Control Box Power Switch (17) to the OFF position,
 - unplug the Control Box power cord from the electrical outlet.

WARNING: The Spray Gun is still electrically charged. Discharge Conducting Pole before touching or you could be shocked.

11. Touch the Conducting Pole (9) to the Ground Clip (10) to discharge any residual electricity.
12. Wipe the Scatter Tip off with a clean cloth.
13. Place the activated charcoal respirator over your face mouth and nose.

WARNING: The fumes produced during curing are hazardous to your health. Do not breathe the fumes.

14. With the oven preheated to the desired temperature (300 to 500 degrees F), place the object on the oven rack, close the door, and turn the ventilation system ON.
 - Typical curing time is 15 minutes. Check the Powder Coating container for recommended curing time and temperature.
 - If the object is large, curing may take more time.
 - The power coating should melt to a smooth, gloss finish all over the object.
 - Check the curing object often to prevent over-curing which can cause roughness to the surface.

15. When cured, turn the oven OFF and open the oven door slightly to allow the object to cool gradually before removing. When the object is cooled too rapidly, a dull finish may result.

Process Tips

1. To remove an orange peel effect after curing, wet-sand the object with 400 grit sandpaper, dry, and repeat the coating process. Over-powder coating can cause this effect.
2. Polish with traditional paint polishes.
3. Lightly buff with a loose wheel and white rouge compound to remove imperfections.
4. Thoroughly clean the Cup before changing powders. Some powders are made from polyester, while others are made from polyurethane. A mixture of both can cause pitting of the coated object.
5. Porous metal objects may need a thorough cleaning with a brush and pre-painting cleaning solutions.
6. If the powder starts to buildup in one place, blow off with light air pressure. Moisture in the air will cause powder buildup. Replace the Disposable Moisture Separator (8).
7. Poor disbursement can be caused by low air pressure. Adjust the air pressure or replace the Disposable Moisture Separator. The Cup should have at least one inch of powder during coating.
8. Use automotive paint remover to remove a cured coating.

MAINTENANCE

1. Wear disposable vinyl gloves.
2. Unplug the Control Box line cord from the electrical outlet.
3. Discharge the Conducting Pole (9) to the Ground Clip (10).
4. Disconnect the air hose from the Spray Gun.
5. Remove the Cup and pour any remaining powder back into it's original container.

WARNING: Powder clouds/mist are explosive. Before cleaning, remove any possible ignition source in the area .

6. Using compressed air, blow out the Cup and all other parts that have collected powder.
7. Uncontaminated powder residue can be stored and reused.
8. Store powder and Powder Coating System in a box located in a clean and dry location.

PARTS LIST

Item	Description	Qty
1	Control Box	1
2	Spray Gun	1
3	Spray Gun Pipe	1
4	Cup*	1
5	Air Outlet Pipe	1
6	Air Input Pipe	1
7	Trigger	1
8	Disposable Moisture Separator (reorder item #42980)	1
9	Conducting Pole	1
10	Ground Clip	1
11	Pedal Switch	1
12	Scatter Tip	1
13	Emitter	1
14	Regulating Screw	1
15	Power Indicator Light	1
16	Running Indicator Light	1
17	Power Switch	1
18	Pressure Reducer Valve	1
19	Hose Adapter	1

***Note:** Replacement cups provided for other powder coating systems (such as SKU 93306, 94646, or 94244) may not seal properly. Only use the cups provided.

Note: Some parts are listed and shown for illustration purposes only and are not available individually as replacement parts.

ASSEMBLY DRAWING

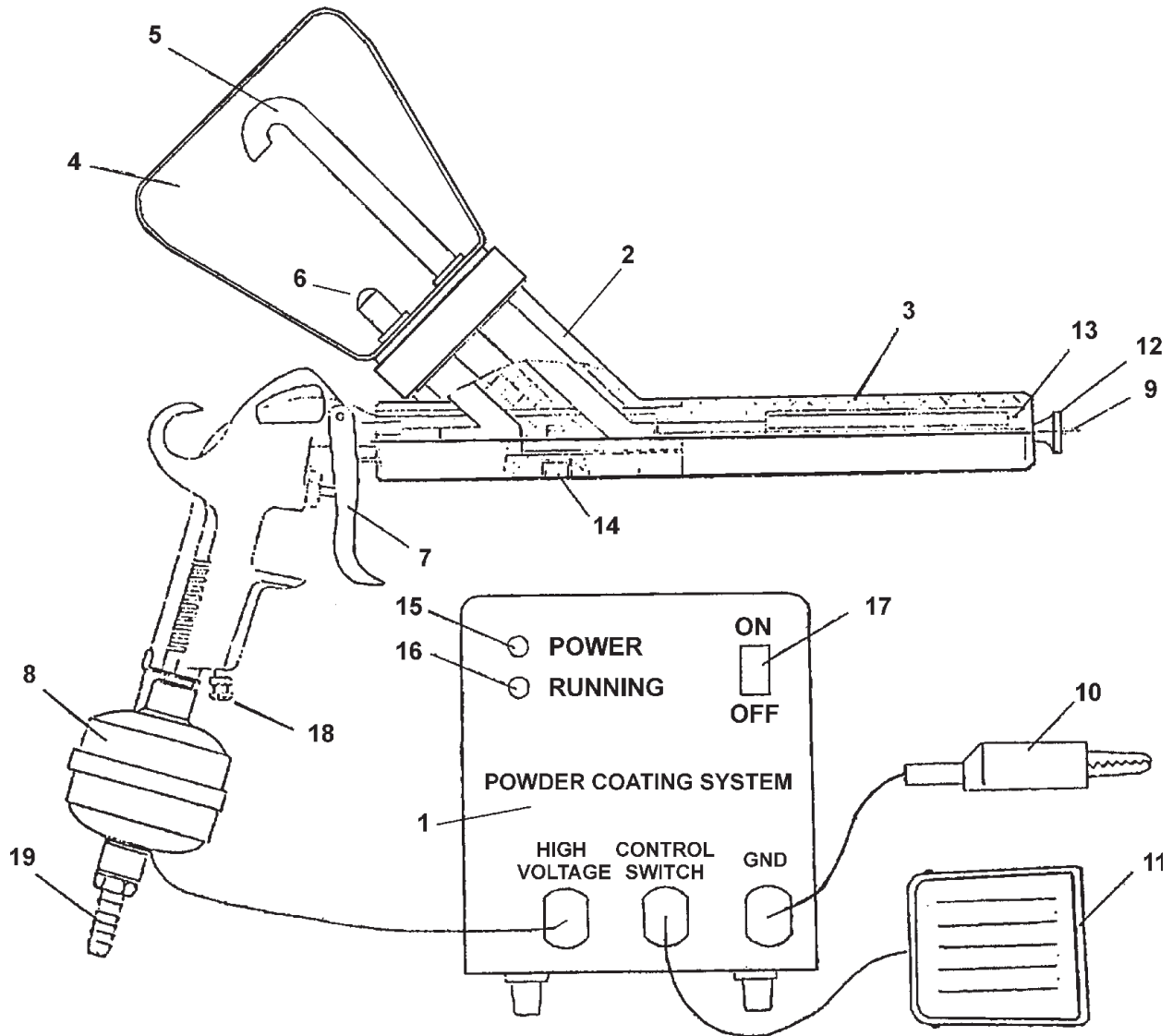

PLEASE READ THE FOLLOWING CAREFULLY

THE MANUFACTURER AND/OR DISTRIBUTOR HAS PROVIDED THE PARTS DIAGRAM IN THIS MANUAL AS A REFERENCE TOOL ONLY. NEITHER THE MANUFACTURER NOR DISTRIBUTOR MAKES ANY REPRESENTATION OR WARRANTY OF ANY KIND TO THE BUYER THAT HE OR SHE IS QUALIFIED TO MAKE ANY REPAIRS TO THE PRODUCT OR THAT HE OR SHE IS QUALIFIED TO REPLACE ANY PARTS OF THE PRODUCT. IN FACT, THE MANUFACTURER AND/OR DISTRIBUTOR EXPRESSLY STATES THAT ALL REPAIRS AND PARTS REPLACEMENTS SHOULD BE UNDERTAKEN BY CERTIFIED AND LICENSED TECHNICIANS AND NOT BY THE BUYER. THE BUYER ASSUMES ALL RISK AND LIABILITY ARISING OUT OF HIS OR HER REPAIRS TO THE ORIGINAL PRODUCT OR REPLACEMENT PARTS THERETO, OR ARISING OUT OF HIS OR HER INSTALLATION OF REPLACEMENT PARTS THERETO.

LIMITED 90 DAY WARRANTY

Harbor Freight Tools Co. makes every effort to assure that its products meet high quality and durability standards, and warrants to the original purchaser that this product is free from defects in materials and workmanship for the period of 90 days from the date of purchase. This warranty does not apply to damage due directly or indirectly, to misuse, abuse, negligence or accidents, repairs or alterations outside our facilities, criminal activity, improper installation, normal wear and tear, or to lack of maintenance. We shall in no event be liable for death, injuries to persons or property, or for incidental, contingent, special or consequential damages arising from the use of our product. Some states do not allow the exclusion or limitation of incidental or consequential damages, so the above limitation of exclusion may not apply to you. THIS WARRANTY IS EXPRESSLY IN LIEU OF ALL OTHER WARRANTIES, EXPRESS OR IMPLIED, INCLUDING THE WARRANTIES OF MERCHANTABILITY AND FITNESS.

To take advantage of this warranty, the product or part must be returned to us with transportation charges prepaid. Proof of purchase date and an explanation of the complaint must accompany the merchandise. If our inspection verifies the defect, we will either repair or replace the product at our election or we may elect to refund the purchase price if we cannot readily and quickly provide you with a replacement. We will return repaired products at our expense, but if we determine there is no defect, or that the defect resulted from causes not within the scope of our warranty, then you must bear the cost of returning the product.

This warranty gives you specific legal rights and you may also have other rights which vary from state to state.

3491 Mission Oaks Blvd. • PO Box 6009 • Camarillo, CA 93011 • (800) 444-3353