

## Microphones for Musicians

The studio dynamic cardioid microphone type MD 421 as described on pages 14 and 15 has been used successfully by professional musicians for many years, both for live stage work and recording purposes.

The popularity of this microphone increased in stage application with the advent of the black and gold version MD 421 de luxe. As an all purpose music microphone the MD 421 series is excellent, however, it became obvious, particularly with the increasing demand on the beat scene for a good vocalist microphone, that Sennheiser electronic should produce such a unit. This in mind design laboratory developed the MD 409 N and the MD 415 N.

The MD 409 N dynamic microphone was designed for stand mounting to be used by instrumentalists who are unable to hold microphones, yet the properties of the microphone will allow the user to come within close proximity without distortion or exaggerating the bass response. The anti feedback properties built into the capsule allow the microphone to be used within a few feet of the loudspeaker without experiencing any "howl round". The MD 409 is fitted with a silent operating ON/OFF switch. The bass response in the MD 409 and MD 415 has been specially calibrated to avoid any bass overload when a vocalist is operating within a few inches of the diaphragm.

The MD 415 N has been especially designed for the vocalist. With all the acoustical features of the MD 409 N the MD 415 can be quickly released from a floor stand providing the MZA 415 microphone adaptor is used. An anti popping shield is built over the diaphragm for close work and the microphone case is turned in brass for ruggedness. Both the MD 415 and the MD 409 are finished in black and gold. The output of both microphones is balanced and wired to the N standard (page 12) and can be used with long cables.

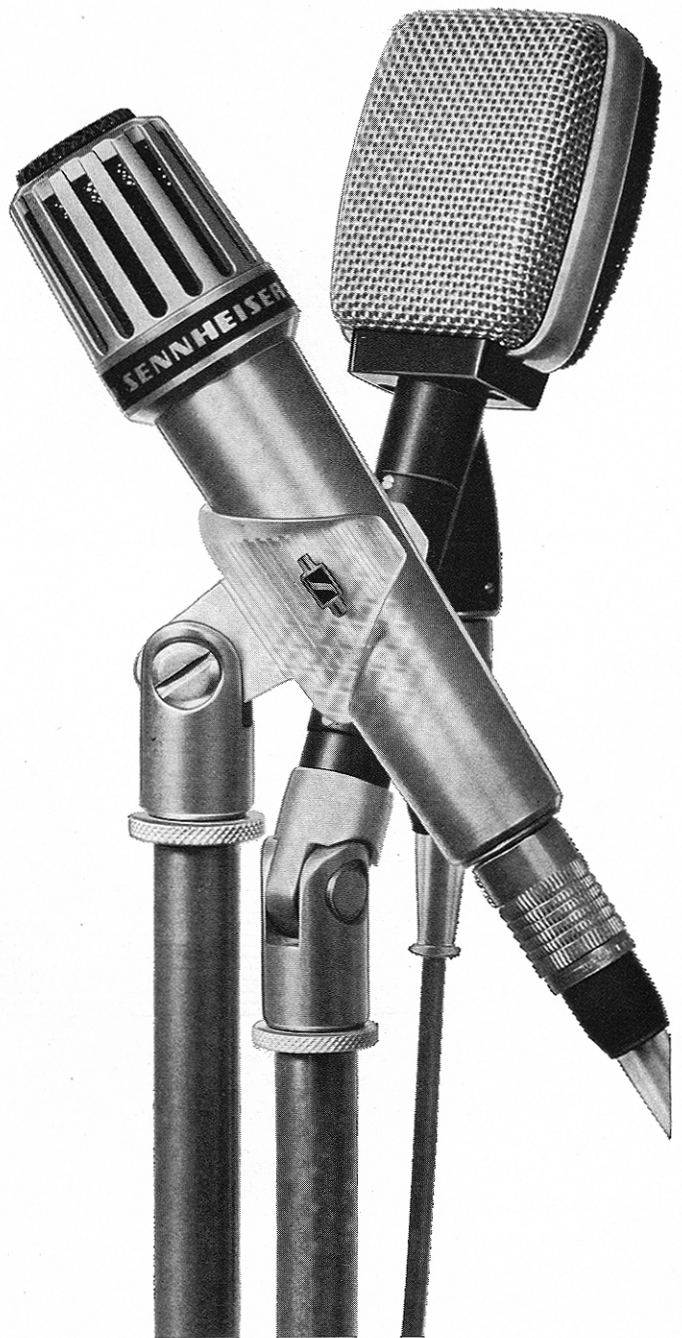

MD 415 N

MD 409 N

# Technical Data

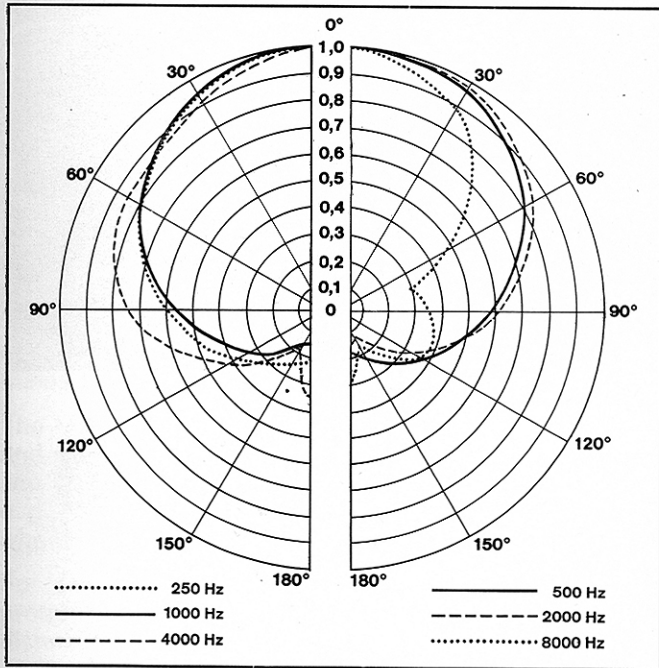

Polar diagram MD 409 N

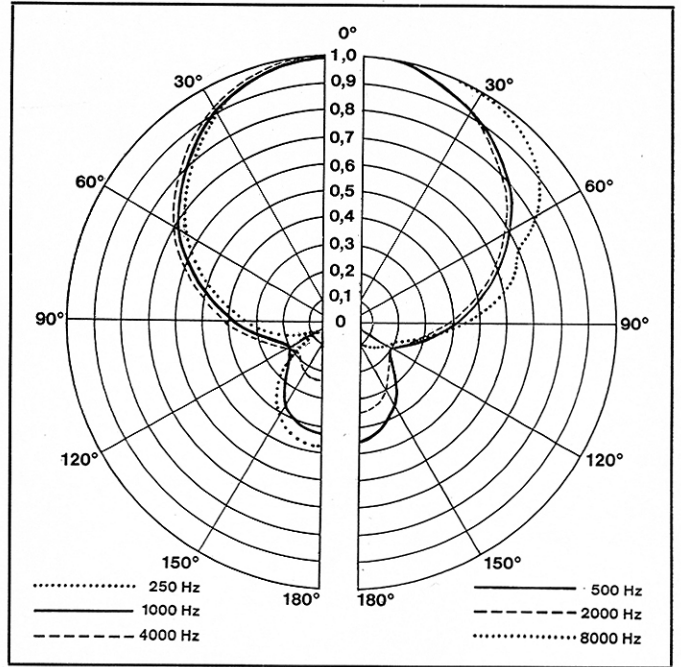

Polar diagram MD 415 N

## MD 409 N

Acoustical mode of operation . . . . .	Pressure gradient transducer
Frequency range . . . . .	50 - 15,000 Hz
Directional characteristic . . . . .	Super-cardioid
Attenuation at 145° at 1,000 Hz . . . . .	≥ 14 dB
Sensitivity at 1,000 Hz . . . . .	0.18 mV/μbar
Impedance at 1,000 Hz . . . . .	200 ohms
Output socket . . . . .	T 3260
Cable connector . . . . .	T 3261/1
Pin connections . . . . .	1 + 3: signal 2 + case: ground
Dimensions . . . . .	55 mm x 35 mm x 195 mm
Weight . . . . .	12 oz.

## MD 415 N

Acoustical mode of operation . . . . .	Pressure gradient transducer
Frequency range . . . . .	60 - 15,000 Hz
Directional characteristic . . . . .	Super-cardioid
Attenuation at 1,000 Hz . . . . .	≥ 18 dB
Sensitivity at 1,000 Hz . . . . .	0.12 mV/μbar ± 3 dB
Impedance at 1,000 Hz . . . . .	300 ohms
Output socket . . . . .	T 3260
Cable connector . . . . .	T 3261/1
Pin connections . . . . .	1 + 3: signal 2 + case: ground
Dimensions . . . . .	35 mm φ, 140 mm length
Weight . . . . .	11 oz.

We reserve the right to alter the specifications especially with regards to technical improvements.