

# VR88

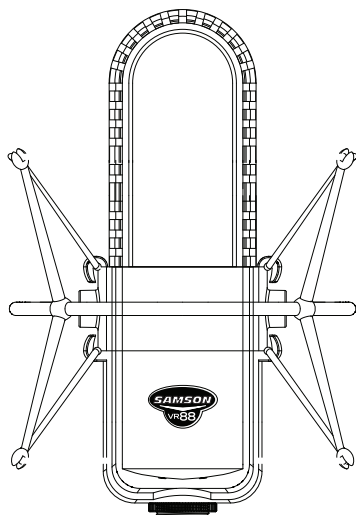

**Active Velocity Ribbon Microphone**

## **Owners Manual**



Copyright 2007, Samson Technologies Corp.

Printed January, 2007 v1.0

Samson Technologies Corp.

45 Gilpin Avenue

Hauppauge, New York 11788-8816

Phone: 1-800-3-SAMSON (1-800-372-6766)

Fax: 631-784-2201

[www.samsontech.com](http://www.samsontech.com)

# Table of Contents

VR88 Proper Care and Handling .....	3
Introduction .....	4
VR88 Features .....	5
Operating the VR88 .....	6
Operating the VR88 .....	7
VR88 Applications .....	8
VR88 Applications .....	9
VR88 Applications .....	10
Using the SP88 Shock-Mount.....	11
VR88 Specifications .....	12 - 13

---

## VR88 Proper Care and Handling

Your new VR88 ribbon microphone is a sophisticated audio instrument and with proper care and handling it will provide years of enjoyable and reliable performance. Follow each point below to ensure your microphone remains in good condition.

- Handle the VR88 carefully and avoid dropping the microphone.
- Always store the VR88 in its case. It's a good idea to keep the case upright so that the microphone is at a ninety-degree angle with the floor or storage shelves.
- Always keep the included sock on the microphone when you're handling it or when it's set up but not in use. Always cover the microphone with the included sock when moving the microphone around the studio or sound stage.
- Be mindful of, and protect the microphone's ribbon element from direct blasts of air.
- Whenever possible, use a pop filter on vocals and other plosive sounds to avoid excessive blasting on the ribbon element.
- Be sure to lower the mixer's channel and master faders when connecting or disconnecting the microphone, and when switching the phantom power supply on and off.
- Be sure to use good working, high quality cables like the included Samson Tourtek TM20L XLR mic cable.
- Keep the microphone clean and free from contact with any foreign particles.
- Don't use the VR88 in close proximity of an AC motor.
- While traveling on an aircraft, never transport the VR88 in a non-pressurized luggage compartment. If possible, hand carry it on to the plane.
- If you lend your VR88 to a friend, make sure that they are familiar with the operation of ribbon mics and understand all of the points above.

---

## Introduction

Congratulations on your purchase of the VR88 velocity ribbon microphone from Samson Audio! The VR88 features a fine, pure aluminum corrugated foil ribbon suspended within an intense neodymium field producing a warm and natural response that's silky smooth from bottom to top. The VR88 combines the sweetness of traditional classic ribbon technology with the precision and versatility of advanced condenser microphone head-amplifier electronics. Like a modern condenser microphone, the VR88 operates on standard 48-volt phantom power. This provides the VR88 with a high output that's compatible with any mic pre amplifier. Unlike old ribbon microphones, you don't have to worry about impedance mis-matches and the VR88 has no problems with long cable runs. The VR88 is capable of handling high sound pressure levels (135 dB), making it an excellent choice for miking vocals, as well as acoustic instruments and even percussion or loud guitar amplifier stacks.

In these pages, you'll find a detailed description of the features of the VR88 Studio Condenser Microphone, as well as step-by-step instructions for its setup and use, and full specifications. You'll also find a warranty card enclosed—please don't forget to fill it out and mail it in so that you can receive online technical support and so we can send you updated information about these and other Samson products in the future. Also, be sure to check out our website ([www.samsontech.com](http://www.samsontech.com)) for complete information about our full product line.

With proper care, your VR88 will operate trouble free for many years. We recommend you record your serial number in the space provided below for future reference.

Serial number: \_\_\_\_\_

Date of purchase: \_\_\_\_\_

Should your unit ever require servicing, a Return Authorization number (RA) must be obtained before shipping your unit to Samson. Without this number, the unit will not be accepted. Please call Samson at 1-800-3SAMSON (1-800-372-6766) for a Return Authorization number prior to shipping your unit. Please retain the original packing materials and if possible, return the unit in the original carton and packing materials. If you purchased your Samson product outside the United States, please contact your local distributor for warranty information and service.

---

## VR88 Features

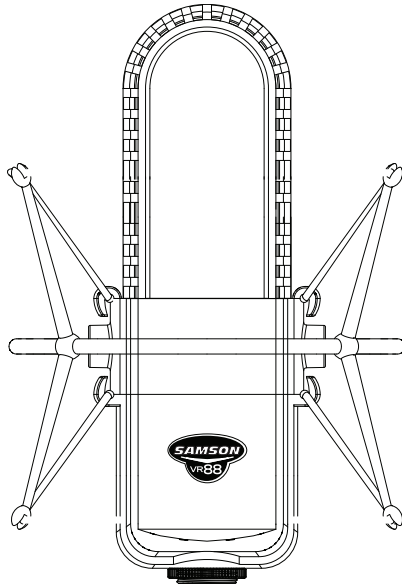

### VR88 Features

- Active Velocity Ribbon Microphone.
- The microphone's element features a 2.5-inch long, 2-micron thin, 99 percent pure aluminum corrugated ribbon, set in a precise flux field created by a precision tooled, neodymium magnet structure.
- Bidirectional, Figure-8 pick-up pattern.
- Active head amplifier with 48 volt phantom power operation.
- Capable of handling signals with high (135 dB) SPL's (Sound Pressure Levels).
- Smooth and transparent sound reproduction great for warming up digital tracks.
- Internal shock-mount.
- Solid die cast construction.
- Shockmount and swivel stand mount included.
- Samson Tourtek 20-foot right angle XLR cable included.
- Aluminum carry case included.

---

# Operating the VR88

## Powering the VR88

The VR88 features an active head amplifier and therefore needs to be operated by connecting a phantom power supply. Phantom power is standard on most quality mixers, outboard mic-pres and hard disk recorders. If necessary, an external phantom supply can also be used. The VR88 receives the phantom power directly from a mic cable when connected to a mixer or other microphone input that includes a phantom supply. Most mixers have a switch to engage the phantom power so be sure to check that the phantom power is on.

## Polar Pattern

The most important characteristic of any microphone is its directionality or “pick-up pattern”. There are three basic categories of pick up patterns; omnidirectional, unidirectional and bidirectional. Omnidirectional mics pick up sound from all directions while unidirectional, or cardioid, mics pick up the sound from the front and reject the sound from the rear. Bidirectional, or figure-8, mics pick up the sound directly in front and back of the microphone while rejecting the sound on the left and right sides.

While omni and unidirectional microphones are very useful for a variety of applications, the VR88's bidirectional pick up pattern is very desirable and performs well in many recording situations. You can use the bidirectional pattern to capture room ambience by carefully placing the microphone between the sound source and studio walls. You can also capture the simultaneous performance of two instruments or vocalists by positioning the microphone directly between them, so one is addressing the front of the microphone and the other the rear.

## Microphone Placement

In order to maximize the sound quality, you must pay careful attention to the placement of your VR88 and how it is positioned for the instrument or vocalist that you are miking. The VR88 is a side address microphone employing a bidirectional pick up pattern, so it picks up sound from the front and rear. All microphones, especially unidirectional and bidirectional microphones, exhibit a phenomenon known as “proximity effect.” Very simply put, proximity effect is a resulting change in the microphone's frequency response based on the distance of the mic capsule relative to the sound source. Generally, you will get a bass boost when miking in close. It is also important to pay attention to the direction of the microphone's element. When you point a unidirectional or bidirectional mic directly at the sound source (on axis) you will get the best frequency response, however when you start pointing the microphone slightly away (off axis) you will notice the high frequency response dropping off and the microphone will start to sound like it has more bass.

For most vocal applications you'll want to position the microphone directly in front of the artist. The same may be true for miking instruments, however, you can make



---

# Operating the VR88

some pretty amazing equalization adjustments by slightly changing the angle of the capsule to the sound source. This can be a very useful technique in capturing the optimum sound of a drum set, acoustic guitar, piano or other instruments in a live room or sound stage. Experimentation and experience are the best teachers in getting good sounds, so plug in! For more information on microphone placement, see the section, "*VR88 Applications*" later in this manual.

## Setting Up the Signal Level

When connecting the VR88 to a mixer or recorder input, be sure that the input is of microphone level. Also, be sure that the phantom power is engaged (as explained the previous section "*Powering the VR88*"). Most mixers and recorders of reasonable quality will offer a microphone input with mic trim (usual called Trim or Gain) control. The purpose of the mic trim control is to optimize the amount of good signal to any noise associated with the mixers electronics. A good mic pre with trim also will have a PEAK or CLIP LED. To set a good level on the mic, set the VR88 up in front of the desired sound source and slowly raise the mic trim control until you see the PEAK LED light up. Then, turn the mix trim control down until the LED does not light any more. On most mixers, the ideal setting is that the trim control is turned up as much as possible without lighting the PEAK LED.

## P-Popping

P-Popping is that annoying pop that you can get when the microphone diaphragm gets a blast of air from a vocalist pronouncing words with the letter "P" included. There are a few ways to deal with the problem including using an external pop filter. Some famous engineers have relied on an old nylon stocking stretched over a bent clothes hanger, which actually works very well, but can be a little smelly. You can also try placing the microphone slightly off axis (on a slight angle) from the vocalist. This can often solve the problem without using an external pop filter. However, on the VR88 or any ribbon microphone, use of an external pop filter like the Samson PS01 is strongly recommended.

## Stand Mounting the VR88

The VR88 can be mounted to a standard microphone stand using the included swivel mount adapter. If you are using a U.S. 5/8" mic stand, you will need to remove, by unscrewing, the Euro stand adapter from the swivel's threaded insert. Simply screw on the swivel adapter on your mic stand or boom arm. Now, loosen the thumbscrew and adjust the microphone to the desired angle. Once set, tighten the thumbscrew to secure the microphone in place. For more information on using the swivel and shockmount, see the section "*Using the SP88 Shockmount*" on page 11 in this manual.

# VR88 Applications

The VR88 is an excellent choice for miking a variety of sound sources including vocals, piano, reed and brass instruments, electric and acoustic guitars and choirs and orchestras to name just a few.

## Vocals

When using the VR88 on vocals, use of an external pop filter is strongly recommended. Position the microphone in front of the artist so that the microphone grill is approximating 4 to 10 inches away. You can record a group of vocalist by positioning them around the front and rear of the microphone. Just remember that the extreme sides of the microphone picks up nothing due to the VR88's bidirectional pick up pattern. Since the VR88's frequency response remains flat off axis, you don't have to be concerned about the microphone sounding different from center to sides.

## Reed Instruments

When recording saxophone or clarinet, place the VR88 one to two feet from the instrument. When placing the microphone closer to the source, you will capture more of the direct sound and less of the reflected sound. Be aware of the reflected sound when positioning the artist and microphone near the studio walls. Often you can use the wall to capture some natural echo.

Ever notice that saxophonists like to warm up in some corner somewhere? They're telling you something. You can change the delay time by adjusting the distance between the microphone, performer and the wall. Experiment around and you can get some amazing recordings.



Figure 1.

## Brass

Recording brass instruments is handled very nicely by the VR88. The VR88 should be positioned approximately two feet away when recording brass instruments. (figure 1.) If you are recording a group of brass and reed instruments increase the distance of the microphone. (figure 2.)

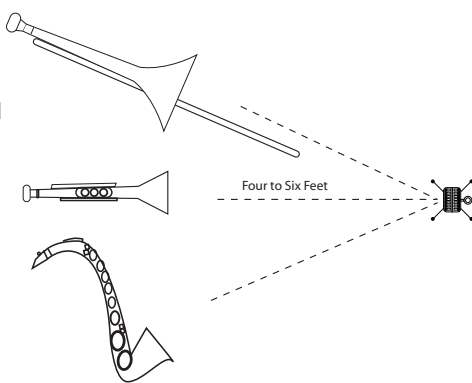

Figure 2.

## Piano

There are many great techniques for recording piano, regardless of what microphone you use. Often piano tracks are recorded in stereo so using two VR88's is a great solution. The VR88's are an excellent choice on piano since their active ribbon technology does not exhibit the comb filtering normally associated with condenser microphones. When recording piano, you first need to decide what kind of sound is required for the project. For an ensemble performance a more direct or up front sound will be captured with the microphones positioned closer to the strings. So if you want the track to lie in the mix position move the mics closer (favoring the mid and upper strings). For a solo performance, position the microphones further back from the piano to capture more of the room ambiance.

---

# VR88 Applications

## Strings

When recording a solo string instrument like a violin, place the VR88 one to three feet from the instrument. When recording a string section, try to position one or more VR88's several feet from the players. If the size of the room permits, raise the microphones three or four feet above the section and position them at a 45-degree angle, facing down.

## Drums

The VR88 is an excellent overhead microphone to record drums. For stereo overheads, use two VR88's approximately four feet above the kit. You can set the spread depending on how large the kit is, however, generally you position one over the hi-hat and the other over the floor tom.

## Recording Sounds With High SPL

The VR88 can handle very high SPL's however blasts of wind can be very damaging to the microphone's ribbon. Therefore, you need to be certain that the microphone is not receiving harmful blasts of air. Kick drum, electric guitar and bass amplifiers are all examples of common sound sources that can produce blasts of air that can be damaging to your VR88. A simple way to check if there is too much wind blast, is to position your hand where you want to place the mic, if you can feel the air blast, don't place the microphone there. Another way to protect the ribbon from air blast is to ensure that the microphone is positioned at a slight angle, either vertical or horizontal. It is important that the microphone element does not take a direct blast of air, so a little bit of tilt will help prevent harm to the ribbon.

## Guitar amp

On guitar amplifiers, the VR88 will capture the nuance of the performance along with some serious low frequency response. The round bottom end is well suited for reproducing the warm tone of a jazz guitarist's hollow body and also for delivering the serious chunk desired by today's modern, drop down guitarists. As with other high SLP sounds, you'll want to position the microphone at an angle off-axis to the sound source. Position the microphone two to ten inches from the speaker and angle the microphone 7 to 15 degrees off-axis. The side view shows a vertical positioning technique. Figure 3.

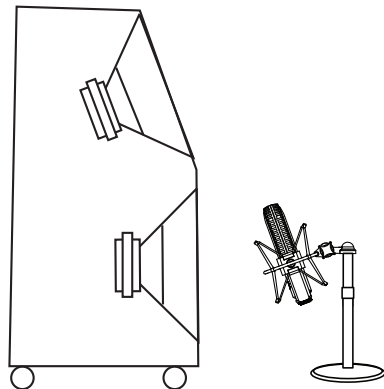

Figure 3.

# VR88 Applications

## Kick Drum

The VR88 is an excellent kick drum microphone, but due to the powerful wind blast they produce you must be extremely careful on how you position the microphone.

For direct miking, position the microphone at least 18 inches from the drum.

For closer miking, place the microphone 10 to 18 inches, but be sure to position the microphone at a 45 degree angle to avoid excessive wear to the ribbon. Figure 4.

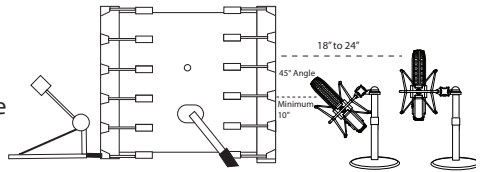

*Kick Drum Side View*

Figure 4.

The top view shows a horizontal positioning technique with the microphone tilted 7 to 15 degrees off-axis. Figure 5.

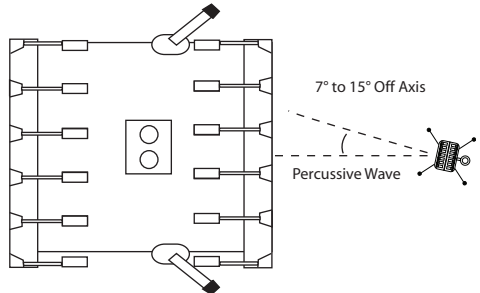

*Kick Drum Top View*

Figure 5.

# Using the SP88 Shock-Mount

## Using the SP88 “Spider” Shock-Mount

For mounting the VR88 to a mic stand you can use the included swivel adapter or for additional isolation the VR88 can be fitted on the included SP88 “Spider” shock mount. Follow the steps below to install the swivel or SP88 shockmount.

- First, screw the swivel mount or shock mount onto your mic stand or boom arm. If you’re using a US 5/8” mic stand or boom, remove the Euro adapter.
- Install the VR88 into the swivel or shockmount by fitting the microphone into the center of the holder, positioning the VR88 all the way to the bottom mounting plate. (Figure 1)
- Secure the swivel or shockmount by reinstalling the threaded collar, rotating clockwise until tight. (Figure 2)
- Now, loosen the thumb screw to adjust the angle of the microphone and position the VR88 to the desired location. Once set, tighten the thumbscrew to secure the microphone in place.

**Note:** Be careful not to cross thread or over tighten the threaded collar or thumb screw.

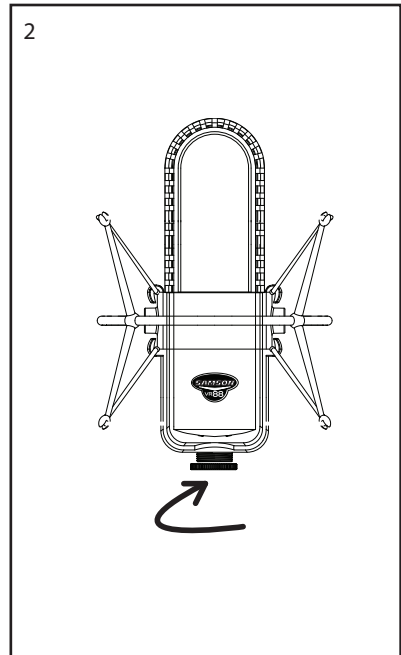
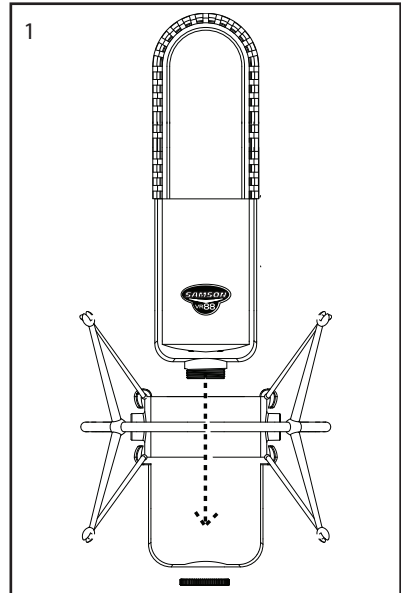

# VR88 Specifications

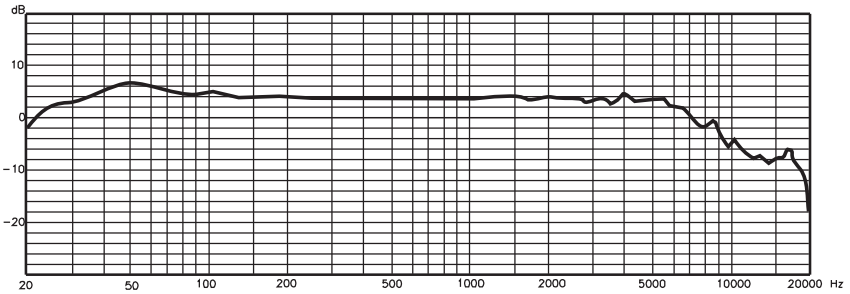

VR88 Frequency Response

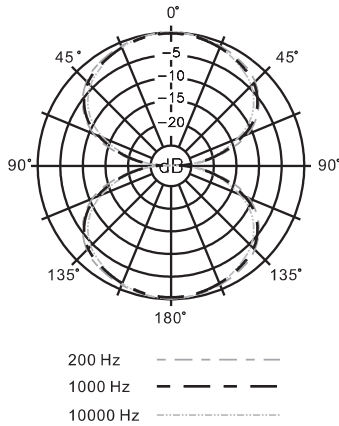

VR88 Polar Response

## VR88 Specifications

Frequency Response	30 ~ 16000 Hz
Polar pattern	Bi-directional (Figure 8)
Element type	Velocity Ribbon
Ribbon thickness	2 microns
Sensitivity	-40 dB/Pa
Max SPL	135 dB
Equivalent Noise Level	17dB
Impedance	200 ohms
Minimum Load Impedance	1000 ohms
Power supply voltage	phantom power 48V +/-3V
Weight	1.1 lbs. (500 g)
Dimensions	Height: 7" (175 mm) Width: 2.125" (54 mm) Depth: 2.125" (54 mm)

*Specifications subject to change without notice.*



Samson Technologies Corp.  
45 Gilpin Avenue  
Hauppauge, New York 11788-8816  
Phone: 1-800-3-SAMSON (1-800-372-6766)  
Fax: 631-784-2201  
[www.samsontech.com](http://www.samsontech.com)