

PEAVEY[®]
ARCHITECTURAL ACOUSTICS[®]

ACM™ 1

Miniature Unidirectional Microphone

SPECIFICATIONS

SPECIFICATIONS:

Element Type:

Electret Condenser

Polar Pattern:

Unidirectional (Cardioid)

Front-to-back Rejection:

20 dB typical

Impedance:

Low - approximately
500 ohms, balanced

Frequency Response:

50 to 20,000 Hz

Sensitivity:

Output Power Level:
-52 dB (0 dB = 1 mW/Pascal)

Open Circuit Voltage:
-67 (0 dB = 1 Volt/dyne/cm²)

Signal to Noise Ratio:

Approximately 64 dB re 1 Pascal

Maximum SPL:

124 dB at 1 kHz

Power Requirements:

7-52 volt phantom

Phasing:

Positive (inward) acoustic pressure
at diaphragm produces positive
voltage at pin #2

Finish:

Low gloss black

Cable:

25' miniature 2 conductor, shielded

Connector:

Microphone: Tiny QG
Output Module: 3 pin XLR type

Dimensions:

See line drawing

Weight:

Microphone (only): 0.4 oz. (11 gm)
With Cable: 2.6 oz. (73 gm)
Output Module: 2 oz. (57 gm)

Furnished Accessories:

Hanging adaptor, foam windscreen,
output module mounting clips,
cable clamps

FEATURES:

- **Back electret condenser element**
- **Small, unobtrusive design**
- **Unidirectional polar response**
- **Smooth, wide-range frequency response**
- **25' miniature cable for long drops**
- **7-52 volt phantom capability**

DESCRIPTION

The ACM™ 1 is a very small, unidirectional condenser microphone designed primarily to be suspended over choirs, instrumental ensembles, or stage areas for sound reinforcement and/or recording.

The small size allows one or more ACM 1 mics to be hung or "flown" in virtually any application with no distraction or sight-line obstruction. It can also be easily concealed in scenery or props when desired.

The very uniform, cardioid polar response is highly effective in suppressing feedback and unwanted sounds, as well as in minimizing undesirable coloration of off-axis sources.

Since the ACM 1 is primarily designed to be hung somewhat above the projection axis of the performer, a subtly rising high frequency response characteristic is incorporated into the design. This characteristic compensates for the high frequency roll-off inherent in this kind of pickup.

A formed wire hanging adaptor is supplied to facilitate proper positioning of the microphone when suspended by

The very small diameter cable is quite inconspicuous in hanging applications, but is well shielded and rugged enough to reliably support the ACM 1 and its hanging adaptor.

The cable plugs into a compact, cylindrical Output Module which connects to the usual XLR-type, 3-pin microphone cable connector. Power is obtained from any phantom source supplying from 7 to 52 volts.

APPLICATION NOTES

CHOOSING POSITION

When hanging one or more ACM 1's to reproduce a choir or instrumental group, the specific positioning for optimum sound quality, balance, and feedback control depends on many factors. The size and nature of the performing group, the configuration of the performance area, the auditorium and the sound system characteristics can all be important considerations.

In general, the microphone(s) are hung somewhat above and in front of (downstage from) the front row of performers. The microphones are usually aimed to point slightly above the nearest performers.

If the ensemble is large enough to require more than one microphone for good balance, the "3 to 1 rule" should be observed. This simply means that the spacing between adjacent microphones should be at least three times the distance to the nearest performers for best overall sound quality.

Some experimentation during rehearsals generally proves very helpful in determining the optimum hanging locations.

For properly hanging the ACM 1, the formed wire hanging adaptor should be used. The microphone's cable is threaded through the coils, with the large coils toward the microphone, so that it is retained by each of the three coiled suspension areas.

The cable end of the microphone is then inserted into the large coils until the projecting portion is firmly engaged. For final aiming, the wire adaptor may be bent at the angled section as needed.

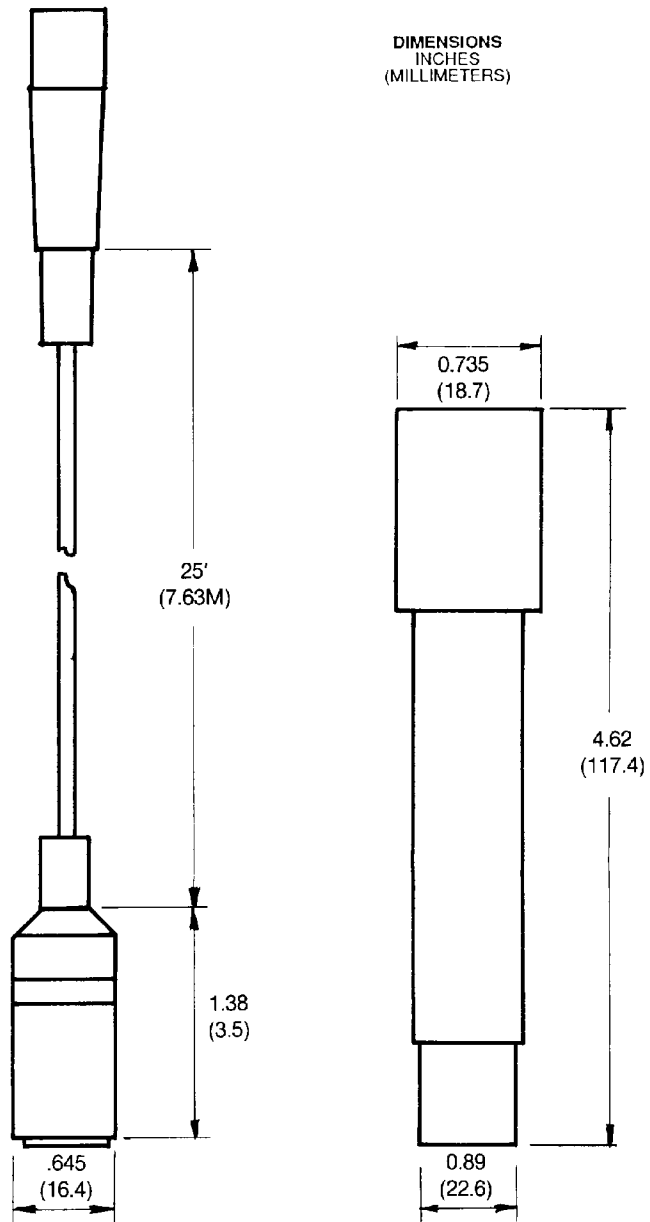
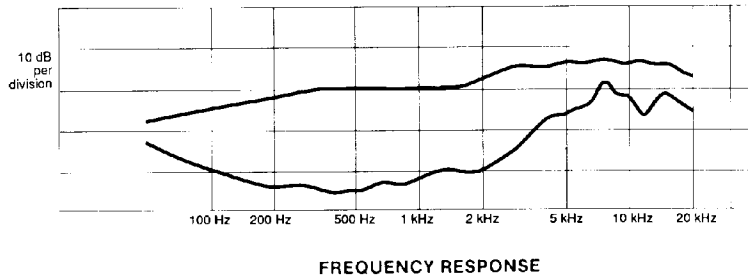

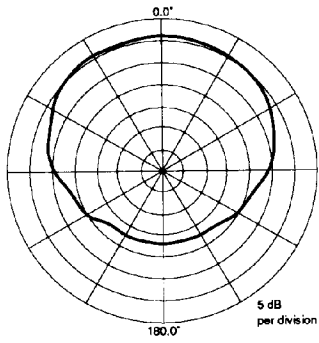

100Hz

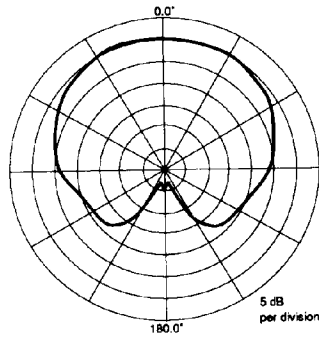

250Hz

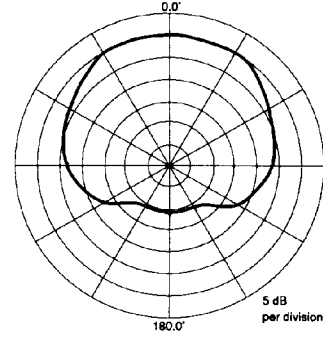

500Hz

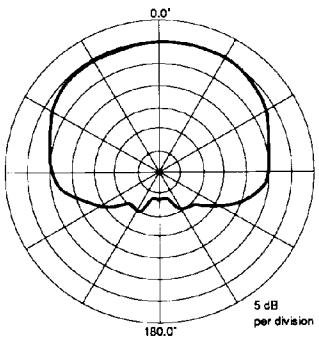

1K

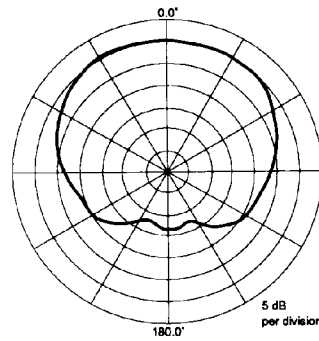

2.5K

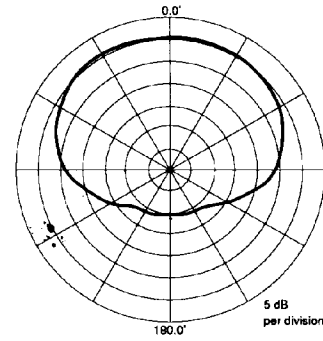

5K

POLAR PATTERNS

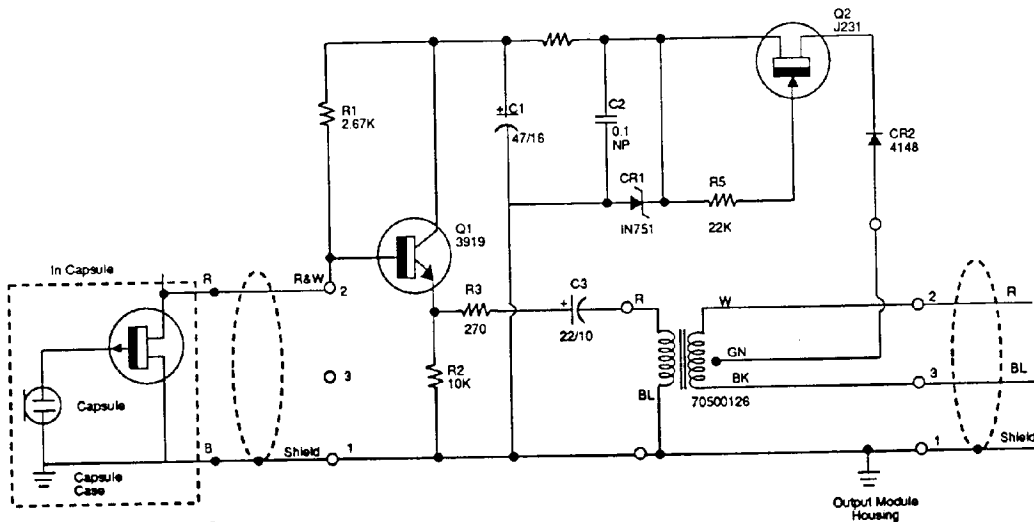

NOTE: Positive (Inward) Acoustic Pressure At Diaphragm Produces Positive Voltage At Pin #2

HANGING SUGGESTIONS

The ACM 1 is designed to be suspended by its attached cable. For ease in properly securing the cable to the supporting structure, two small cable clamps are provided.

NOTE: The output module is intended to be connected to the cable attached to the ACM. Longer cables between the microphone and output module can result in performance deterioration.

When first hung, the microphone will tend to rotate as the cable relaxes. It is suggested that the unit first be hung facing **away** from the desired position. After 24 hours it should have turned to about the desired direction. Small additional adjustments should be made by simply rotating the microphone slightly in the hanging adaptor.

ARCHITECTURAL & ENGINEERING SPECIFICATIONS

The microphone shall be a back electret condenser type with a frequency response of 50 Hz to 20 kHz.

The microphone shall have a cardioid polar pattern with a rear response which is typically -20 dB from the front response. The microphone shall have an output power level of -52 dBm where 0 dB = 1 milliwatt per Pascal, and a nominal impedance of 500 ohms when connected to its output module. The microphone shall have a low gloss black finish. Microphone dimensions shall be .645" diameter by 1.38" long, with an attached 25' cable, 0.10" in diameter. The cable shall be terminated with a miniature 3 pin connector to interface with the output module electronics package.

The output module shall have a low gloss black finish and be 0.89" in diameter by 4.62" long. The diameter at the output connector end shall be reduced to permit direct connection with a panel mount input connector of the 3 pin XLR type. The output module shall properly interface the microphone with any 7 to 52 volt phantom supply. A vinyl coated hanging adaptor shall be included for proper aiming of the microphone when suspended by its cable. The microphone shall be an Architectural Acoustics ACM™ 1.

ONE YEAR LIMITED WARRANTY--

Note: For details, refer to the warranty statement. Copies of this statement may be obtained by contacting Peavey Electronics Corporation, P.O. Box 2898, Meridian, Mississippi 39302-2898.



Features and specifications subject to change without notice.

A Division of **Peavey Electronics Corporation**

711 A Street, P. O. Box 2898, Meridian, MS 39302-2898 / (601) 483-5376 / Telex: 504115 / Fax: (601) 484-4278

#80301306

©1990

Printed in U.S.A. 8/90