

NEWCON OPTIK™ 2007

Printed in Canada



LONG RANGE  
LASER RANGE FINDER  
LRB 20000

---

In USA: 2331 Superior Ave. Cleveland, OH 44114  
In Canada: 105 Sparks Ave., Toronto, ON M2H 2S5

**NOTES:**

---

---

---

---

---

---

---

---

---

---

---

---

---

---

---

---

---

---

---

---

**19. ACCEPTANCE CERTIFICATE**

**LASER RANGEFINDER LRB20000**

Serial Number \_\_\_\_\_ corresponds to all technical specifications and has passed the quality inspection.

Date of production: \_\_\_\_\_

Quality Inspector signature: \_\_\_\_\_

Quality assurance seal

## **18. CUSTOMER SUPPORT**

Should you experience any difficulties with your Newcon OPTIK product, consult the enclosed manual. If the problem remains unresolved, contact our customer support department at 1(416) 663-6963 or Toll free at 1-877-368-6666. Our operating hours are 9am-5pm, Monday - Friday, Standard East Time.

**At no time should the equipment be sent back to Newcon without following the instructions of our technical support department.**

**Newcon accepts no responsibility for unauthorized returns.**

To locate NEWCON Authorized Dealer call:

Tel: (416) 663-6963 Fax: (416) 663-9065

Email: [newconsales@newcon-optik.com](mailto:newconsales@newcon-optik.com)

Website: [www.newcon-optik.com](http://www.newcon-optik.com)

The defective products should be shipped to:

From USA: 3310 Prospect Ave. Cleveland, OH 44115

From all other countries: 105 Sparks Ave., Toronto, ON  
M2H 2S5, CANADA

## **IMPORTANT INFORMATION**

### **Read prior to activation**

You have just purchased a complicated electronic device, which emits hazardous invisible laser radiation. To operate it properly, please read this manual carefully. Here are some common precautions that must be noted.

- **NEVER** direct laser radiation at people or animals
- **NEVER** stare into direct, scattered or reflected laser beam
- **NEVER** aim the unit at the sun or bright light sources
- **NEVER** subject the unit to impact while operating or being transported
- **NEVER** transport the unit without the case
- **NEVER** disassemble the unit. This device contains high voltage components, which may be hazardous for you!
- **NEVER** reverse polarity of the battery
- **ALWAYS** keep the unit out of the reach of children
- **ALWAYS** remove the battery when the device is not in use for a long period
- **ALWAYS** store in a warm dry place when the device is not in use
- **Caution** - use of controls or adjustments, or performance of procedures other than those specified herein may result in hazardous radiation exposure
- **Caution** - the use of optical instruments such as binoculars, loupes, mirrors, etc. with this product increases eye hazard

## **Features of the LRB 20 000 Laser Range Finder Binocular**

- Digital data output
- First or last target indication
- Built-in compass
- Lightweight
- Rugged
- Meet all military specifications

## **17. WARRANTY**

**NEWCON OPTIK** warrants this product against defects in material and workmanship for one year from the date of the original date of consumer's purchase, but no more than 18 months from the date of manufacturing. Longer warranty periods are available, subject to the terms of specific sales contract. Should your Newcon product prove defective during this period, please bring the product securely packaged in its original container or an equivalent, along with proof of the date of original purchase, to your Newcon Dealer. Newcon will repair (or at its option replace), the product or part thereof, which, on inspection by Newcon, is found to be defective in materials or workmanship.

### *What This Warranty Does Not Cover:*

**NEWCON** is not responsible for warranty service should the product fail to be properly maintained or fail to function properly as a result of misuse, abuse, improper installation, neglect, damage caused by disasters such as fire, flood, lightning, improper electrical current, or service other than by a NEWCON Authorized Service. Postage, insurance, or shipping costs incurred in presenting your NEWCON product for warranty service are your responsibility. Please include a cheque or money order made out to NEWCON OPTIK for the amount of \$15.00 to cover shipping and handling within North America.

If you use Windows 95, 98 or ME:

- Turn computer on and enter the BIOS SETUP in accordance with the computer documentation.
- Set the address of LPT port as 378h, and port type as EPP. Register the new settings.
- After OS on your computer has been loaded, insert the supplied diskette into the floppy disk drive.
- Run program with the name "BDEPP5.EXE".
- Perform measurements as described in the manual. The results will be shown in the communicator program window.

To exit the program, press the space key.

Complete the work in the following order: turn off the LRB20000A power, take the disk out of the disk drive, and turn the computer off.

## **TABLE OF CONTENTS**

- |                              |                                       |
|------------------------------|---------------------------------------|
| 1. Overview                  | 12. Long term storage                 |
| 2. Abbreviations             | 13. Storage rules                     |
| 3. Technical characteristics | 14. Shipment                          |
| 4. Supplied accessories      | 15. Rechargeable battery handling     |
| 5. Principles of work        | 16. Data output to external equipment |
| 6. Safety precautions        | 17. Warranty                          |
| 7. Preparing for use         | 18. Customer support                  |
| 8. Operating procedure       | 19. Acceptance certificate            |
| 9. Serviceability test       |                                       |
| 10. Maintenance              |                                       |
| 11. Troubleshooting          |                                       |

## **1. OVERVIEW**

RANGEFINDER BINOCULAR LRB 20000 is an advanced Laser Rangefinder system that provides instant distance measurements consistently and accurately. The stereoscopic device provides convenient observation with both eyes. Therefore, the LRB 20000 eliminates a need for two separate devices (binocular and rangefinder) combining both requirements in a single device. It is designated for industrial-technical purposes, ground surveillance, observation of individual targets and measurement. It can be used in geological and engineering survey, repair works, maritime navigation, meteorology and tourism.

The rangefinder completed with the Angular Mount is designed for referencing ground location point by the predetermined landmark coordinates and is capable of:

- measuring horizontal angles and magnetic azimuths;
- measuring vertical angles and angles of elevation;
- determination of target and landmark polar coordinates;
- polar-to-rectangular landmark and target coordinate conversion and determination of the OP and target coordinates from the predetermined landmark coordinates.

The supplied software allows data acquisition on IBM PC compatible computers in DOS/Windows environment. To start communication with computer, do the following:

If you use Windows NT, 2000, XP, or 2003 Server:

- Turn off the computer.
- Insert the disk which is supplied with the LRB 20,0000A into the floppy disk drive.
- Turn computer on and enter the BIOS SETUP in accordance with the computer documentation.
- Set the address of LPT port as 378h, and port type as EPP. In boot menu, choose the first bootable device as Floppy Drive. Register the new settings.
- Proceed with loading, choose "5" or just press "Esc" in options menu. After full loading your computer will work under MS-DOS.
- In line a:\> type BDEPP5 and press enter to launch the communication program.
- Perform measurements as described in the manual. The results will be shown in the communicator program window.

## **16. DATA OUTPUT TO EXTERNAL EQUIPMENT**

The measured data can be exported to a remote computer through the connector X2.

To export the output data, you must to apply the voltage of 3 to 8 V from the connected computer to the pin 9 of the connector X2. The amplitude of the output signals will depend on the value of the supplied voltage.

The measured range information is exported in cycles by a binary decimal code through four data and three address buses according to Table 16.1.

The strobe starting the data export appears on pin 8 of the connector X2 in form of a positive pulse edge.

Table 16.1

Address			Data
X2/7	X2/6	X2/5	X2/1, X2/2, X2/3, X2/4
0	0	0	ones of meters (0000 or 0101)
0	0	1	tens of meters (from 0000 to 0101)
0	1	0	hundreds of meters (from 0000 to 0101)
0	1	1	thousands of meters (from 0000 to 0101)
1	0	0	tens of thousands of meters (from 0000 to 0011)

In each cycle, the digits of the binary decimal data code are delivered to the pins of connector X2 in accordance with the schematic circuit diagram of the range finder given in Fig.3.

The rangefinder is operable in the temperature range between – 40 and +50 °C, relative air humidity of up to 98% (as taken at 35 °C), air pressure of 61 kPa (460 mm Hg) minimum, and in the sea mist conditions. It is powered with a rechargeable battery 10 D-0b55C-1. It can be powered with a vehicle electrical system providing (27±2.7) V, or non- rechargeable battery producing from 12V to 14.5V or from 22V to 29 V.

### **Upon receipt of the rangefinder and prior to operation the user should proceed as follows:**

- check to see that the seals on the wooden and metallic packaged are intact;
- check completeness of the range finder against Section 5 of this manual;
- check to see that the serial number of the rangefinder is the same as indicated in Sections 17-19;
- make sure that the optical surfaces are free from grease stains, dirt, cracks and condensed moisture. Remove dirt and grease as directed in item 1 of table 11.1;
- inspect the range finder exterior for physical damage (no cracks, dents, deep rust are admitted);
- check the dehydrator for working condition. If the silica gel is pink in color, replace it with the new one taken from individual SPTA set (item 11.6.3);
- place the battery in operation as directed in Section 16 of this manual (the rechargeable battery is supplied uncharged).

**To secure trouble-free operation of the rangefinder:**

- be prompt in replacing the rechargeable battery by freshly charged when the red LED in the left-hand eyepiece of the range finder starts to illuminate;
- keep the range finder dry at all times especially in the cold season of the year;
- after exposure to subzero temperatures keep the range finder at room temperature for at least two hours before unpacking and then mop up the condensed moisture;
- while operating the range finder at temperatures above 35° C and exposing to direct sunrays, attach cover AEP 42.63.021 taken from individual SPTA set to keep away sunlight. Moistening the cover with water is permitted to cool off the range finder.

After replacement of emitter and (or) control circuit board make entries in Section 4 of this manual as to their new serial numbers and basic characteristics.

- Charged as described under 15.3;
- Discharged by setting the toggle switches to the DISCHARGE and MAIN positions until the DISCHARGED light diode flashes on and off to indicate the discharged condition. Charge up the operating voltage for 15 hours as described under 15.3.

**15.3.3.** The battery that has been stored in the discharged condition for over 3 months is subject to two processing cycles before use.

Cycle 1

- Charging for 24 hours with the toggle switches set to the CHARGE and PREPARATORY positions on the charging device;
- Discharging with the toggle switches in the DISCHARGE and PREPARATORY positions, until the LED labelled DISCHARGED flashes.

Cycle 2

- Charging as directed under 15.3.;
- Discharging with the toggle switches set to the DISCHARGE and MAIN positions on the charging device, until the DISCHARGED diode flashes.

If the minimum discharging time is 5 hours, charge the battery up to the operating voltage as directed in 15.3.

If the discharging time is between 5 and 3.5 hours, subject the battery to another Cycle 2 as described in 15.3.3, then charge it up to the operating voltage as described in 15.3.1.

It's prohibited to use the battery, if the discharging time was under 3.5 hours.



## **15. RECHARGEABLE BATTERY HANDLING**

**15.1.** The rechargeable battery is supplied in discharged condition.

**15.2.** While handling the battery, be certain to:

- avoid contact with any bare circuit components while charging the battery;
- strictly comply with the prescribed charging/discharging procedures.

**NEVER:**

- dismantle the battery;
- store the battery together with acids, or batteries using acids.

**15.3.** The battery is subject to charging at an ambient temperature of  $(20\pm 5)$  °C.

To charge the battery, do the following:

- Unscrew the cover of the battery section on the charging device;
- Place the battery in the section coupling the "+" terminal with the bottom contact of the section, and screw the cover;

Connect the charging device to the power source using the appropriate cable (see in Section 11.3).

**15.3.1.** The battery that has been stored in the discharged condition for a maximum of 28 days is to be charged for 15 hours. The toggle switches are placed in the CHARGE and MAIN positions on the charging device.

**15.3.2.** If the battery has been stored in the discharged condition for a time between 28 days and 3 months, it should be cycled as follows:

## **2. ABBREVIATIONS**

The following abbreviations are used herein:

AC ckt – automatic control circuit,  
AI – angular mount,  
CD – charging device,  
DCC – direct current converter,  
ER "0" – zero elevation reference,  
F ckt – firing circuit,  
IDA – information display assembly,  
OP – observation post,  
PD – protective device,  
PhD – photodetector (assembly),  
SB – rechargeable battery,  
SPTA – spare parts, tools and accessories,  
TSGC – time sensitivity gain control,  
TIC – time-interval counter

### **3. TECHNICAL CHARACTERISTICS**

<b>Parameter</b>	<b>Rated and tolerable value</b>
<b>Optics</b>	
Binocular magnification	$(7\pm 0.3)^x$
Binocular angle of vision	$6.7^\circ \pm 20'$
Eye relief, mm	18
<b>Rangefinder</b>	
Range measurement limits, m	100 to 20,000
Measurement error, m, max	$\pm 5$
Time of preparation for range measurement after depressing of MEASURE button, s	3
Range information memory storage time, s	3...5
<b>Emitter</b>	
Wavelength, nm	1.06
Output energy, mJ	15
Pulse duration, ns	6
Beam divergence, no more, mrad	0.6
<b>Miscellaneous</b>	
Supply voltage to generate "Low Battery" light warning circuit operation, V	$11\pm 0,3$
Capacity of pumping capacitors, $\mu\text{F}$	18 to 22
Weight, kg, max	2.5
Overall dimensions, mm, max	110x215x225
In-service operating life, measurements, min	50,000

**NEVER** store the rangefinder on the floor near heaters.

The rangefinders are arranged in the storage room so that steel and iron objects are at least 2 m away.

To prevent demagnetizing of the needle, the latter should be aligned with the magnetic meridian. To achieve that, store the packing cases so that the arrow marked on top points to the North.

Charged batteries may be stored together with the rangefinder unit for up to three months.

**13.3.** The rangefinder placed in short-term storage (up to 3 months) is subject to inspection as directed in Section 10.5 and Long Term Storage as directed in Section 12.

**13.4.** If the rangefinder is to be stored for over three months, discharge the batteries as directed in Section 15.

### **14. SHIPMENT**

**14.1.** The rangefinder unit is to be shipped in wooden package AEP 42.83.368. The rangefinder can be shipped by any transport means. During shipping, it must be protected against precipitation, spray and sun rays.

**14.2.** Before transit, the rangefinder must be closed down and all its components are secured in the metallic package AEP 42.86.184 (Fig. 7). All locks and hinges of package and case are secured.

**14.3.** When carrying the rangefinder in a truck, stow it in the front with the cover up and secure to prevent impacts.

**11.3.5.** The individual SPTA set is packed in the case 4 (Fig. 7). The case contains the spare rechargeable battery, pencil, eraser, cloth and coordinate converter.

**12. LONG TERM STORAGE**

To preserve the rangefinder, proceed as follows:

- cap the rangefinder connectors by paper and tie a cord round;
- coat the range finder bright work with grease GOI-54P;
- pack up all range finder components in metallic package;
- secure all locks and hinges of package and with grease GOI-54P;
- pack up the tripod in recess on package cover and fasten by belt;
- insert rangefinder unit into polyethylene bag;
- insert the sack with silica gel into the bag and weld it.

**13. STORAGE RULES**

**13.1.** The rangefinder is stored in closed rooms specially equipped to provide weather protection, i.e. protection against atmospheric precipitation, solar effects, dust, sand, wind, sharp fluctuations of temperature and outside air humidity.

The storage room temperature is to be maintained between -40 °C and +50 °C and relative humidity of up to 98% taken at 35 °C and below. Avoid moisture condensation in the premises.

**13.2.** Each rangefinder unit in wooden package is kept on a wooden rack or shelf with handle up.

The principal parameters of the emitter with serial number \_\_\_\_\_, fitted into the rangefinder, are as follows:

Parameter	Ambient temperature		
	-40° C	normal conditions	50° C
Minimum operating pumping voltage $U_{oper.min.}, V, max$			
Maximum operating pumping voltage $U_{oper.max.}, V, max$			
Pumping voltage temperature coefficient $TKH_n, V/^{\circ}C$	-		-
Capacity of storage capacitors $C_c$ of emitter test set, F	-		-

The principal parameters of the control circuit board with serial number \_\_\_\_\_, fitted into the rangefinder, are as follows:

Ambient temperature, ° C	Pumping voltage $U_{pump.}, V$
-40	
Normal conditions	
50	

**Note:** The principal characteristics of the emitter and the control board, given in the above tables, are intended for service entities as a reference data.

#### **4. SUPPLIED ACCESSORIES**

<b>Description</b>	<b>Designation</b>	<b>Qty</b>	<b>Serial No.</b>	<b>Remarks</b>
Rangefinder	AEP 41.46.712	1		
Tripod (optional)	G 42.14.067	1		
Angular mount (optional)	G 42.21.812	1		
Rechargeable battery	10D-0,55C-1	2		
Fuse link VP1-1 1,0 A 250 V		5		
Sealing ring	G 68.79.193-	2		
Framed lens	02	1		
Membrane	G 44.21.885	2		
Eye shield	AEP 75.48.092	2		
Diaphragm	G 47.92.131	1		
Pencil TM, M, CT, T	AEP 73.54.031	1		
Wrench		1		
Synthesized fiber brush KXOOK No. 7	AEP 87.61.505	1		
Coordinate converter	G 42.41.211	1		
Cable	AEP 48.44.037	1		
Cable	AEP 48.44.038	1		
Cable	AEP 48.44.039	1		
Cable	AEP 48.44.040	1		
Cable	AEP 48.44.120	1		

- protection device 12, used to supply the rangefinder with (27±2.7) V DC or 22-29 V from a vehicle electrical system, or with 22-29 V or 12-14.5 V from external batteries;
- cable 14, used to couple the protection device to the electrical system of a track-laying vehicle;
- cable 15, used to connect the protection device to external rechargeable battery type 6CT70 (or analogous);
- cable 16, used to connect the protection device or charging device to the electrical system of a wheeled truck;
- cable 17, used to couple the charging device to a mains of 220 V 50 Hz;
- cable 18, used to couple the protection device to external battery type 21NKBN-3,5;
- pencil 3 and eraser 8, used while working with the map and coordinate converter;
- coordinate converter 10, used for polar-to-rectangular coordinate conversion, reference location of the observation post and orientation of the range finder;
- sealing ring 4, used to seal battery section;
- eye shield 5, used to exclude incident light in the eyepiece;
- framed lens 6, used to contribute the angle reading convenience and accuracy when operating the AI;
- membrane 19 to seal the MEASURE button assembly;
- cover 20, to protect the rangefinder against direct sun rays;
- cover 21, used to protect the rechargeable battery against damages.

**11.3.** To correct problems by using the individual SPTA set proceed as follows (see Fig. 6).

**11.3.1.** To replace the fuse link 2 in the protection device:

- Unscrew the threaded cover from the housing of the protection device;
- Remove the defective fuse link;
- Insert the spare fuse link from the SPTA set;
- Screw the cover on the housing of the protection device.

**11.3.2.** To replace the rechargeable battery *I*:

- Open the cover of the battery section;
- Remove the used battery;
- Fit the new battery in the section so that the "+" terminal of the battery is connected with the bottom contact of the section;
- Close the cover of the battery section.

**11.3.3.** To replace the fuse link in the charging device:

- Unscrew the outer threaded covers from the fuses;
- Unscrew the bayonet of the fuse link holders;
- Remove the fuse links;
- Fit in good fuse links;
- Close the holder covers;
- Screw on the outer threaded covers.

**11.3.4.** The individual SPTA set includes the following tools and accessories:

- charging device *II*, operated to charge the rechargeable battery 10D-0,55C-1 from a vehicle electrical system (27±2.7) V DC or 22-29 V and from a commercial line 220 V 50 Hz;

Description	Designation	Qty	Serial No.	Remarks
Eraser		1		
Cloth	G61.93.516	2		
Charging device	AEP 43.79.608	1		
Protection device	AEP 43.79.607	1		
Silica gel		50 g		
Package	AEP 42.86.186	1		
Package	AEP 42.83.368	1		
Package	AEP 42.86.184	1		
Casing	G 42.62.345	1		
Casing	AEP 45.71.018	1		
Cover	AEP 42.63.021	1		
Cover	AEP 42.63.030	1		
Cover	G 42.63.332	1		
Operating manual		1		

**5. PRINCIPLES OF WORK**

**5.1.** The LRB 20000 assembly (Fig.1) consists of rangefinder 1 mounted on the angular mount 2. The latter is mounted on the tripod 3.

**5.2.** Rangefinder (Fig.2) is designed for terrain observation and measuring the distance to the closest or next-in range target caught in the beam. It works with the principle of measuring the light pulse round-trip time. The measurement result is displayed in meters on digital range indicator and can be also stored in the computer for further calculations.

The schematic circuit diagram of range finder (Fig.3) shows rechargeable battery (G1), controls switches (S1- S4), pumping and firing elements (ref. designations C1-C3, E1, L1, T1, V1-V2), control circuit board (A1), display circuit board (A2), counter circuit board (A3), and photodetector assembly (A4). Toggle switch S1 is operated to energize the range finder, and toggle switch S4 – to light up the light-emitting diode (LED) H1 which illuminates the reticle pattern.

Button switches S2 and S3 labeled (MEASURE 1) and (MEASURE L) respectively are used to prepare the rangefinder for taking a measurement (by pressing one of those buttons).

Button S2 is operated to range the closest target, whereas button S3 is used to engage the next-in-range target caught in the beam.

**11.2.** The possible problems with the rangefinder are listed below in Table 11.1

Table 11.1

<b>Problem description</b>	<b>Probable reason</b>	<b>Solution</b>
1. Picture is blurred in the right-hand eyepiece	Condensed moisture, dirt on external optical surfaces Condensed moisture on internal optical surfaces	Clean exterior of optical parts as directed under 10.6.2 Dry rangefinder as directed under 10.6.3
2. Readiness indicator remains dark after MEASURE 1 (MEASURE L) button release	Open circuit in the battery section (when standard battery is used) Blown fuse in the protection device (when vehicle electrical system is used) Open circuit in battery section (when vehicle electrical system is used)	Clean contacts as directed under 10.6.1 Replace fuse as directed under 11.3.1 Clean contacts as directed under 10.6.1
3. Red Low Battery indicator is on	Unallowably low battery voltage	Replace the battery with a newly charged one as directed under 11.3.2

- remove the moist silica gel from the case and fill the case with the fresh one.

Moist silica gel may be subjected to multiple dehydrations at  $(120\pm 3)$  °C without any deterioration of its properties. Using a microwave oven is allowed.

To dehydrate the silica gel, proceed as follows:

- place the silica gel in a clean metal vessel;
- place the vessel on the heat source providing heating up to  $(120\pm 3)$  °C. Measure the temperature directly on the silica gel;
- see the silica gel changing its colour.

The silica gel is dry and good for use when it turns bluish from pink. When heating up, keep the silica gel away from open flames.

## **11. TROUBLESHOOTING**

**11.1.** If the rangefinder or its components do not function properly, first of all check that:

- the rangefinder is properly set up;
- the controls have been operated in the proper succession;
- the optical parts are free from dust, dirt and oil stains on the exterior;
- the battery is charged.

Connector X1 couples the controls and the Rechargeable battery to control circuit board (A1).

C1 and C2 are energy storage capacitors placed in the pumping circuit. They are charged up to 700-1000 V through a special contact located on the control circuit board A1. Capacitor C3 and diodes V1, V2 are placed in the pumping circuit to prevent RF oscillations or reversal of the voltage polarity across capacitors C1, C2. E1 is a pumping flashtube. Transformer T1 produces 10-15 kV firing voltage pulses applied to tube E1. The primary winding of the transformer is furnished with a negative voltage of 130 to 185 V supplied from control circuit board A1. The flashtube is externally ignited. The ignition voltage pulse is conducted to the metal-clad envelope of the tube E1.

DCC, AC ckt, power supplies of the TIC, PhD assembly and battery charge analyzer are mounted on board A1.

The counting-logic circuitry of the TIC and the TSGC of the PhD assembly are located on counter circuit board (A3).

A2 is the information display assembly board. Arranged thereon is the indicating circuit of the TIC: digital range indicator, multiple target indicator, outgoing pulse absence indicator, ranging readiness indicator (green) and battery discharged condition indicator (red). Control signals and supply voltages pass through display circuit board A2 from control circuit board A1 to circuit board A3 and to the PhD assembly.

Circuit boards A1, A2 and A3 are connector-coupled with the PhD assembly. Plug X2 couples the cable of the remote control set to receive range data in binary code.

**5.3.** Angular Mount (Fig. 4) is intended for mounting rangefinder on a tripod, aim the rangefinder to the target and measure the azimuth and elevation values. The main part of the Angular Mount (AI) is body 15, which incorporates the elevation and azimuth worm-gear drives.

Use adjustment knobs 1 and 7 for the fine tuning of the rangefinder. To perform initial tune-up, turn the unit through the desired angle. Read the angles read on azimuth circle 14 and scale 5. The wheels provide accuracy of 1/10 of a division.

Lenses 6 and 10 make the reading easier and more accurate. Azimuth circle 14 is set to zero with knob 11, which should be locked in this position. The horizontal adjustments are made on the Angular Mount by using level 13. Magnetic meridian orientation is achieved with the compass 8.

The rangefinder is fixed on the guides of bracket 3 of the AI, and secured there with lever 2. By rotating the nuts 9 you adjust retainer 4 of the clamping assembly.

The AI is installed on the tripod through the ball mount 12.

**5.4.** The tripod mount (Fig.5) is designed to adjust the height of the rangefinder and Angular Mount as required for the particular aiming position. The tripod consists of three telescoping legs 3 assembled on top in common base 2. Each leg can be deflected independently. The AI is fixed to the tripod through mounting head 1.

**10.6.** Maintenance Servicing Procedure.

**10.6.1.** To clean the contacts in the battery section, wipe the contacts several times with cotton wool moistened with alcohol.

**10.6.2.** To remove dust and dirt from the optical surfaces, use the brush 23 and clean cloth 7 supplied in the individual SPTA set (see Fig. 6).

To remove greasy stains from the optical surfaces, do the following:

- wind some cotton wool around one end a wooden stick;
- moisten the cotton wool with an alcohol and ether mixture (1:1) and gently shake the stick to remove excess mixture;
- wipe the glass surface several times with the cotton wool, avoiding contact with the frame;
- change the cotton wool and move the stick end spiral style from the center towards the periphery to wipe the surface clean;
- while cleaning, watch that the mixture does not stain the frame, for it may dissolve the sealing mastic, causing leakage or ungluing of the lenses.

**10.6.3.** The dehydrator case should be filled with fresh silica gel in a closed room. Under the field conditions, replace the silica gel when the weather is dry and calm. Never keep the case with fresh silica gel open for more than 1 or 2 minutes.

To change the silica gel, proceed as follows:

- prepare fresh silica gel 13 (see Fig. 6);
- unscrew the cover of the dehydrator case with the help of wrench 9 (Fig. 6);



**10.5. In-service Maintenance.**

**10.5.1.** During in-service maintenance, the range finger is checked for serviceable condition in accordance with Steps 1 through 10 of Table 9.1.

**10.5.2.** The unit is not to be dismantled during in-service maintenance.

**10.5.3.** For the servicing scope, refer to Table 10.3.

Table 10.3.

<b>Operations</b>	<b>Procedure as per</b>	<b>Materials, tools and accessories</b>
Servicing within daily scope	As in Table 10.2.	As in Table 10.2.
Cleaning contacts of charging device, protection device, wires and battery section	Para 10.6.1.	Absorbent optical cotton, alcohol
Repair of packing case (when so required)		Equipment, appliances and tools available in repair shop

**10.5.4.** During in-service maintenance, the cycle life of the range finder may not be spent by more than 10 measurements.

The length of each leg is adjusted by retracting or extending the moving section. The coupling nut 4 must be loosened first to change the leg length.

Stay block in the bottom of the head is designated to secure the AI on a log, a stump, or any similar piece of wood suitable for the job.

**6. SAFETY PRECAUTIONS**

**6.1.** Rangefinder LRB 20000 is an optical-electronic device emitting high-density pulses of invisible light at wavelength of 1.06 μm, characterized by the following dangerous factors:

- direct laser radiation;
- mirror-reflected laser radiation;
- diffuse-reflected laser radiation.

**Direct and mirror-reflected laser radiation of the rangefinder is dangerous for naked eyes at 1700 m distance and less.**

**Diffuse-reflected laser radiation is dangerous at 0.43 m distance from reflecting surface.**

Optical devices increase these distances in accordance with optical device magnification ratio.

Laser energy at the output objective lens of the rangefinder exceeds permissible level for skin by 16% and reaches permissible level at 3.77 m distance from the rangefinder.

6.2. According IEC 825 standard the rangefinder belongs to the third class device of laser radiation hazard.

Table 10.2

**NEVER:**

- **Turn on the rangefinder aiming on people or animals;**
- **Measure distance through window and door glasses;**
- **Measure distance to mirror-reflecting surfaces (mirrors, car and building windows, optical components, grinded and polished surfaces), which are nearer than 1700 m to the rangefinder;**
- **Direct radiation to diffuse-reflecting surfaces (walls, curtains, papers), which are nearer than 0.43 m to the rangefinder;**
- **Inspect the rangefinder optical components on the housing side when the selector switch is on.**

6.3. Persons who are in the dangerous zone of laser radiation must wear protective goggles ZH22-72-CZC-22-6 or OZP or similar for eyes protection.

Operations	Procedure as per	Materials, tools and accessories
1. Servicing within Check Inspection scope	Table 10.1	As in Table 10.1
2. Cleaning rangefinder to remove dust, dirt and moisture		Cloth
3. Retouching painted exterior of the rangefinder (when required)		Brush, painting enamel
4. Drying and repair the straps (when required)		
5. Replacing silica gel (when required)		Silica gel
6. Replacing defective components with spares (to be taken from individual SPTA set)	Article 10.6.3  Article 11.3	Individual SPTA set
7. Tightening sleeves on knob end facets	Table 10.1, Article 10.3	

Table 10.1

Operations	Procedure as per	Materials, tools and accessories
1. Cleaning external optical surfaces (when required)	Article. 10.6.2	Lens Brush No. 7 (made of synthetic fibre) Absorbent optical cotton Alcohol
2. Charging of rechargeable battery (when required)	Section 15	

**10.4. Daily Servicing.**

**10.4.1.** During the Daily Servicing, the rangefinder is checked for serviceable condition in accordance with Steps 1 through 10 of Table 9.1.

**10.4.2.** For the daily servicing scope, see Table 10.2.

**6.4.** Only the following persons are admitted to work with the rangefinder:

- who are over 18 years old; and
- who do not have medical contraindications for work with laser emission; and
- who are instructed studied safe methods of operation with the rangefinder regarding the safety rules; and
- who are appointed responsible for operating the rangefinder by the manager of the organization where the rangefinder is in use.

**6.5.** The rangefinder generates life-hazardous high voltage during operation.

**NEVER disassemble the rangefinder yourself!**

Repair the rangefinder only in a specialized shop.

**6.6.** Between operation periods, be sure to cover the rangefinder objective lens with special cap fastened to the housing.

**6.7.** The persons operating the rangefinder should be instructed on how to provide the first medical aid if laser emission burns eyes and skin.

## **7. PREPARING FOR USE**

**7.1.** Choose an observation post.

**7.2.** Rotate the objective frame to bring the reticle to sharp focus.

**7.3.** Check the battery voltage and the rangefinder before operation.

**7.3.1.** To analyze the battery voltage, set the ON-OFF selector switch to the ON position and check if the Low Battery indicator glows red in the left-hand eyepiece. If it does, replace the battery.

**SET SELECTOR TO OFF BEFORE REPLACING THE BATTERY!**

**7.3.2.** To check the rangefinder for proper functioning, proceed as follows:

- Aim the rangefinder on the target with known distance to it;
- Set the ON-OFF selector switch to ON;
- Press and release the MEASURE 1 button;
- As the readiness indicator turns on, release the MEASURE 1 button and read the measured range;
- Compare the range measurement result with the actual distance.

**The rangefinder is in good working order if the range measurement is accurate to 5 m.**

If there is no available target with known distance to it, the rangefinder is checked for proper functioning by measuring the range to the same target three times. The rangefinder is functioning properly, if the measurements differ within 5 m maximum.

**10.2.** Maintenance Service Types and Intervals.

**10.2.1.** While in use, the rangefinder is subject to the following types of maintenance services:

- check inspection;
- daily (routine) service;
- in-service maintenance.

**10.2.2.** The same servicing intervals are established for the component parts and the entire rangefinder.

Check inspection is carried out before using the rangefinder.

Daily servicing is performed after each use. If the rangefinder is not used for a while, the servicing within daily scope may be substituted to biweekly visual inspection of the dehydrator condition and, if is needed, replacement of the silica gel and the rechargeable battery.

In-service maintenance is performed every six months and before placing the rangefinder in short-term storage.

**10.3.** Check Inspection.

**10.3.1.** During the Check Inspection the serviceable condition of the rangefinder is checked as directed in Steps 1 through 7 in the Table 9.1.

**10.3.2.** The check inspection scope is outlined in the Table 10.1.

Table 9.1, continued

Items to check, test procedure	Technical requirement
Sensitivity, indexing uniformity and balance of the magnetic needle. Proceed as directed under 7.6.2.	Send the unit for repair if even a single requirement of 8.6.2. is not satisfied.
AI azimuth and elevation adjustment knobs must not be loose.	If necessary, tighten bushings on knob end facets.

## **10. MAINTENANCE**

**10.1.** Maintenance Organization and Procedure. General Instructions.

**10.1.1.** This Section deals with the maintenance services prescribed for the range finder, excepting the battery servicing procedure. For the instructions on the battery service procedure, refer to Section 15.

**10.1.2.** The range finder is serviced to ensure its operability and readiness for operation.

The rangefinder is subject to timely full-scope servicing, unless premature wear should occur resulting in shorter periods between repairs.

**10.1.3.** While preparing for and carrying out the maintenance services, observe the safety precautions as outlined in Section 6.

**7.4.** To use the AI and tripod for observation, proceed as follows:

- Arrange the tripod on selected site so that one leg aligns with the ranging direction;
- Extend the telescopic legs at the desired length to achieve maximum convenience for the observation.

In case you do not use the tripod proceed as follows:

- Unscrew the ball-mount seat from the tripod base;
- Fit the stay block on to the wooden object and tighten it.
- Install and level the AI using the ball-mount by turning AI in ball-mount seat and putting the level bubble into the centre of the ring marks.
- Secure the AI by clamp.
- Sliding the rangefinder along the AI bracket guides, fit the AI clamp into the T-shaped opening in the rangefinder bracket, and turn the handle of the clamp to lock the rangefinder in this position.

**7.5.** Use the AI compass or the reference directional angle to align the rangefinder with the base line.

**7.5.1.** To align the range finder with the base line, proceed as follows:

- Aim the rangefinder to the reference point;
- Find the base reference (BR) from the formula:

$$BR = \alpha_{\text{base}} - \alpha_{\text{ref}} \pm 30.00'$$

where  $\alpha_{\text{base}}$  is the base line directional angle;

$\alpha_{\text{ref}}$  is the directional angle of the given reference line.

- Rotate the azimuth dial to align the base reference value with the zero wheel. Now the rangefinder is aligned with the base line within 30.00 mils;
- Turn the clamping handle to lock the azimuth dial in the determined position.

**7.5.2.** To orient the rangefinder by using the reference directional angle, proceed as follows:

- Aim the range finder to the reference point, which directional angle is known;
- Rotate the azimuth dial to set the reference directional angle;
- Turn the clamping handle to lock the azimuth dial in the determined position.

With the rangefinder oriented, the measurements are taken from the location point relative to the directional angle of the object (reference object).

**7.5.3.** For the magnetic orientation of the rangefinder, proceed as follows:

- Unscrew the plunger knob all the way out to release the magnetic needle of the compass;
- Turn the AI around the vertical axis to obtain precise alignment of the index mark of the circle with the magnetic needle;

Rotate the azimuth dial to set the magnetic azimuth index correction.

## **9. SERVICEABILITY TEST**

The principal tests to be performed on the range finder are listed below.

Table 9.1

<b>Items to check, test procedure</b>	<b>Technical requirement</b>
Rangefinder completeness	Range finder is complete with all components listed in Section 5
Rangefinder exterior	Exterior surfaces are clean and free from cracks, dents and rust
Exterior of range finder optical parts (to be checked visually). Make sure that the unit is off!	Optical surfaces are free from cracks, scratches, chips, dirt, grease stains (exterior) and condensed moisture (interior)
Dehydrator case of range finder (to be checked visually)	Silica gel is bluish in colour
Battery voltage. Proceed as directed under 7.3.1	The red Low Battery indicator is not lit in the left eyepiece of the rangefinder
Illumination of range finder Binocular reticle. Check that the front cover of the rangefinder is closed and set ILLUM. selector switch to ON	Binocular reticle is illuminated
Functioning of range finder. Proceed as directed under 7.3.2.	Measured results are within 5 m of predetermined range
Setting of zero elevation reference (ER "0"). Proceed as directed under 7.6.1.	ER "O" error determined for vertical angle scale should be calculated for the elevation measurements.

Plot the target on the map using the obtained rectangular coordinates.

**8.9.** When using the rangefinder under the conditions of insufficient light, set the ILLUM. selector switch to ON.

**8.10.** If a target is located against an intense background (bright sky, sunlit snow or sand, etc.), the range display may indicate as if more than one target is caught in the beam, and the range indications may differ every time that MEASURE L button is depressed. To eliminate the adverse background effects, the frame of the binocular objective lens should be fitted with the diaphragm 22 (Fig. 6) and secured by means of a pin and rubber clamp on the case.

Don't use the diaphragm in low temperatures, in mist and limited visibility conditions.

When using the compass to orient the rangefinder, keep in mind that the indexing accuracy of the magnetic needle is affected by the nearby iron or steel objects. The motor vehicles and similar massive objects must be at least 10 m away, medium-size objects (hammers, pliers, similar tools) must be at least 0.5 m away, and small-size things (flashlights, knife, screwdriver, etc.) must be 20 cm away from the unit.

**7.6.** To check the range finder for proper operation when using the AI and the tripod:

- Check the AI zero elevation reference (ER "0");
- Check the AI compass.

ER "0" is the setting of the elevation scale that corresponds to the horizontal position of the range finder Binocular axis.

**7.6.1.** To check the zero elevation reference, proceed as follows:

- Stick a pole at 50 to 100 m away from the unit and mark it with the rangefinder objective height above the ground level;
- Aim the reticle crosshair to the mark and read the tilt angle (A1);
- swap the rangefinder and the pole positions, and apply another mark to the pole in accordance with the new height of the rangefinder objective;
- Aim the crosshair to the new mark of the pole and read again the tilt angle (A2);
- find the ER "0" from the formula:

$$ER "0" = \frac{A1 + A2}{2} ,$$

The A1 and A2 values are entered with their respective signs. If the ER "0" value is other than zero, the respective correction is to be taken into account while operating the range finder. The error value is subtracted from the elevation measurement, if the latter is positive, and added, if it is negative.

**7.6.2.** To check compass, set up the AI for operation. Then, check the sensitivity and balance the needle.

For the purpose proceed as follows:

- Level the AI;
- Release the needle;
- Unbalance the needle by using a knife or a screwdriver.

To make sure that the needle is free from defects, check that:

- The needle oscillates in a smooth and uniform manner to regain balance;
- The position of the needle end is the same as the mark when the needle settles;
- The needle ends are leveled with the marked plates within  $\pm 0.5$  mm.

The compass requires triple checking. If even a single requirement is not satisfied, the AI needs repair.

**7.7.** After the rangefinder check is complete, set the ON-OFF and ILLUM. selector switches to the OFF position.

- Mark numbers of the plotting board with respect to the selected scale ( 1:25, 000 or 1:50,000) and the reference point, observation post and target location;
- Read the rectangular coordinates of the reference point from the map and note them down on the plotting board or card;
- Align the circular scale zero of the plotting board with the zero wheel;
- Use the reference grid of the plotting board to plot the reference point on the circular scale in accordance with the map coordinates;
- Set the circular scale of the board to read the directional angle as determined for the reference point from the observation post;
- Draw a vertical line from top downwards through the reference point marked on the circular scale. See that the line is parallel with the grid lines;
- Use the rule to lay off the OP-to-reference point range on the drawn line. Mark the obtained OP location point on the circular scale;
- Adjust the circular to read the directional angle as determined for the target from the observation post;
- Pass a vertical line from bottom upward through the OP point in parallel with the grid lines on the circular scale;
- Use the rule to lay off the OP- to-target range on the drawn line. Mark the target location with a dot and symbol;
- Setting the circular scale to zero, read the target and OP rectangular coordinates off the board. Note down the coordinates on the board or card;



- Vertical angles up to 0.80 mils and elevation angles falling within  $\pm 0.40$  mils may be read off the reticle with a maximum accuracy of 0.05 mils.

**8.7.** To determine the polar coordinates, proceed as follows:

- Use the compass to orient the Angular Mount as directed under 7.5.3;
- Aim the rangefinder to the object;
- Read the azimuth of the object;
- Range the object as directed under 9.3.

**8.8.** To convert the polar coordinates into rectangular coordinates, proceed as follows:

- Take out the coordinate converter from the case;
- Release the clamp and detach the rule from the reverse side of the plotting board;
- Determine the polar coordinates of the reference point and the target as directed under 9.7 and note them down on the plotting board or a special card;
- Calculate from the determined magnetic azimuth  $A_m$  of the reference point and the target to find the directional angles, reckoning in the compass correction  $\Delta A$  obtained from the formula:

$$\alpha = A_m - \Delta A_m$$

- Read the compass correction  $\Delta A_m$  of the map;
- Note down the reference point target directional angles on the plotting board of card;

## - **8. OPERATING PROCEDURE**

**8.1.** The rangefinder is designated to:

- Survey the ground;
- Range fixed targets;
- Range moving targets;
- Take azimuth and magnetic azimuth measurements;
- Take elevation and vertical angle measurements;
- Find polar coordinates of targets and reference objects;
- Convert the polar coordinates of the target and reference object into rectangular coordinates, and find the target and observation post coordinates from the predetermined reference coordinates.

**8.2.** To use the rangefinder for ground surveillance, aim it with hands roughly on the desired object, and then adjust it fine by rotating the azimuth and elevation knobs.

**8.3.** For ground surveillance do the following:

- Set the ON-OFF selector switch to the ON position;
- Aim the rangefinder on the target so that it is observed in the central gap of the reticle as close as possible to its centre, and the screening objects (bushes, trees, terrain elevations, etc.), which are located near the target or partially mask it, are outside the gap. Locate the target in the lower portion of the gap, touching the bottom mark of the reticle;
- Press the MEASURE 1 button, wait until the readiness indicator comes on and release the button.
- Read the measured range. It will be displayed on the range indicator for 3 to 5 seconds.

If there is more than one target on the laser beam path (a wire in front of a building), the decimal point is displayed in the least significant digit position of the range indicator. In this event, the rangefinder may be used to range the first or the last target by pressing the MEASURE 1 or MEASURE L button respectively. If it is possible, repeat the target ranging once or twice. If the obtained range is correct, the results will not differ by more than 5 m.

**8.4.** To range a moving target, do the following:

- Observing the target through the binocular eyepiece, track the target elevation and azimuth;
- Press the MEASURE 1 button (or MEASURE L button, when engaging the last-in-range target);
- As the readiness indicator comes on, aim the range finder at an off-set point forward of the target;
- As the target aligns with the reticle gap, release the MEASURE 1 (MEASURE L) button;
- Read the measured range.

**8.5.** To take azimuth and magnetic azimuth measurements, proceed as follows:

- Align the vertical mark of the Binocular objective reticle with the right-hand object;
- Read and note down the azimuth dial indication accurate to 1/10 of a division on the wheel;
- Align the vertical mark of the reticle with the left-hand object and read the angle again;
- Determine the measured angle by subtracting the second value from the first one.

**Binoculars rangefinder unit LRB 20000 in packing case**

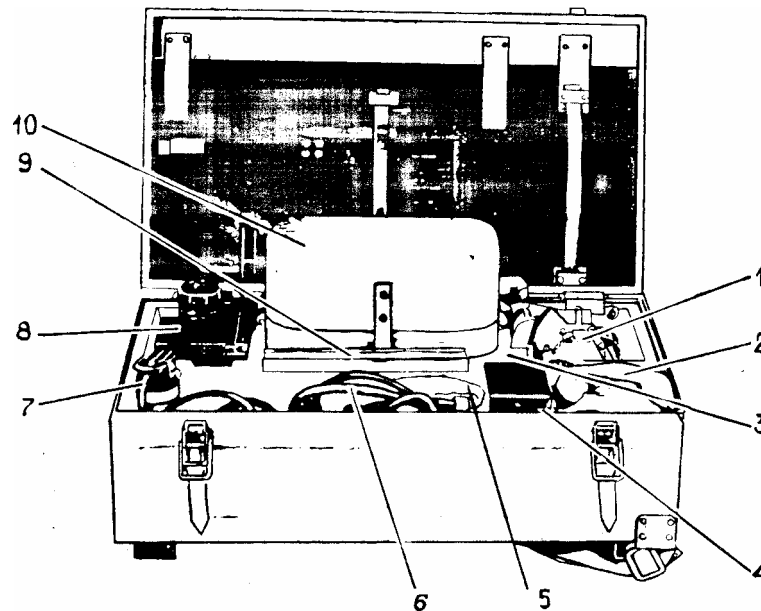

1 - Angular mount; 2 - Cover; 3- Rechargeable battery 10D-0,55C-1; 4 - SPTA package; 5 - Cover; 6 - Cable; 7 - Protection device; 8 - Charger; 9 – Operation manual; 10 - Rangefinder in case

Fig.7

### Individual SPTA set

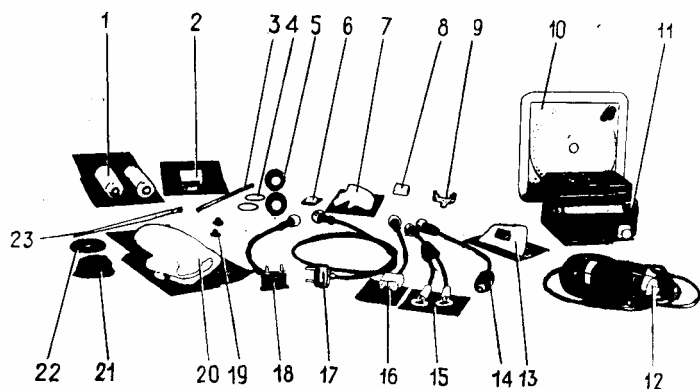

- 1 - Rechargeable battery 10D-0,55C-1; 2 - Fuse link VP1-1 1,0A 250 V; 3 - Pencil; 4 - Sealing ring; 5 - Eye shield; 6 - Framed lens; 7 - Cloth; 8 - Eraser; 9 - Wrench; 10 - Coordinate converter; 11 - Charging device; 12 - Protection device; 13 - Indicating silica gel; 14...18 - Cables; 19 - Membrane; 20, 21 - Cover; 22 - Diaphragm; 23 - Brush No. 7 (made of synthetic fibre)

Fig. 6

Add 60.00 mils to the first value if it is exceeded by the second.

During the magnetic orientation of the rangefinder, the angles read off the azimuth dial are the magnetic azimuth values (bearings) of the target (or reference object). You should count the magnetic azimuth correction (see 7.5.3.).

For better precision, take 3 or 4 angle measurements to calculate the mean value. After each measurement of the magnetic azimuth value (bearing), destroy the rangefinder orientation and aim it again.

An azimuth or magnetic azimuth measuring under 0.80 mils may be read off the reticle with a maximum accuracy of 0.05 mils (small division value of the reticle is 0.05 mils, large division value is 0.10 mils).

**8.6.** To measure vertical and elevation angles, proceed as follows:

- Align the horizontal mark of the rangefinder reticle with the upper object;
- Read the vertical angle scale using the wheel and note down the value;
- Rotate the azimuth and elevation knobs to align the horizontal mark of the reticle with the lower object and read the scale again;
- Determine the vertical angle by subtracting the smaller value from the greater one if both have the same sign (are of the same color), or by adding them, if the signs are opposite.

The elevation is measured with reference to the Binocular axis of the rangefinder. Hence, the rangefinder should be thoroughly levelled before taking the elevation measurements.

**Laser rangefinder binoculars LRB 20000**



1 - Rangefinder; 2 - Angular Mount; 3 - Tripod

Fig. 1

**Tripod mount**

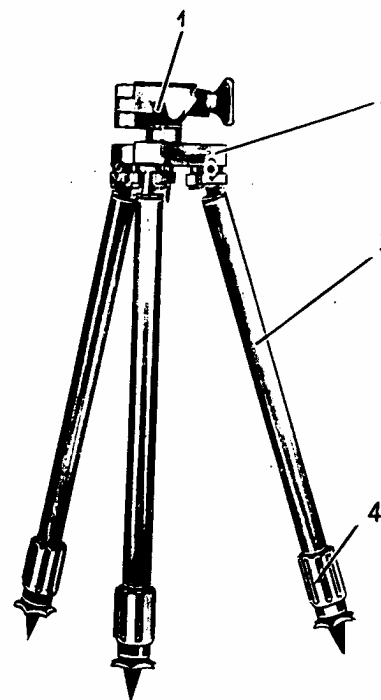

1 - Mounting head; 2 - Base; 3 - Legs; 4 - Nut

Fig. 5

### Angular Mount

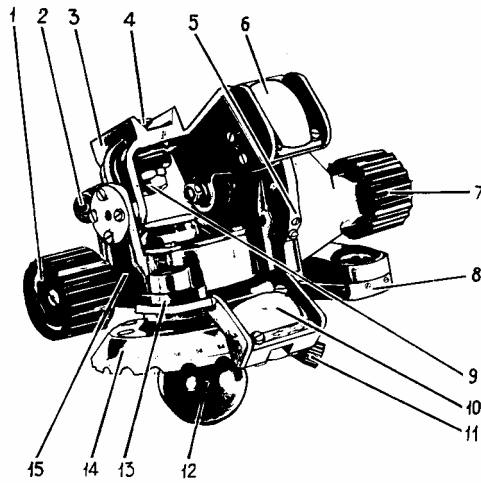

1 - Adjustment knob; 2 - Lever; 3 - Bracket; 4 - Retainer; 5 - Scale; 6 - Framed lens; 7- Adjustment knob; 8 - Compass; 9 - Nut M8; 10 - Framed lens; 11 - Knob; 12 - Support; 13 - Level UK-10; 14 - Azimuth circle; 15 - Body

Fig. 4

### Rangefinder rear view

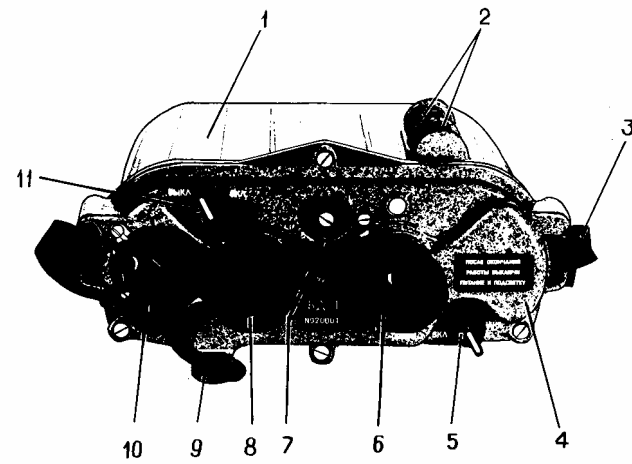

1 - Housing; 2 -MEASURE 1 and MEASURE L buttons; 3 - Belt; 4 - Panel; 5 - ILLUMINATION toggle switch lever; 6 - Binocular eyepiece; 7- Screw; 8 - Indicator eyepiece; 9 - Plug MP-1; 10 - Battery section cover; 11 - ON-OFF toggle switch lever

Fig. 2

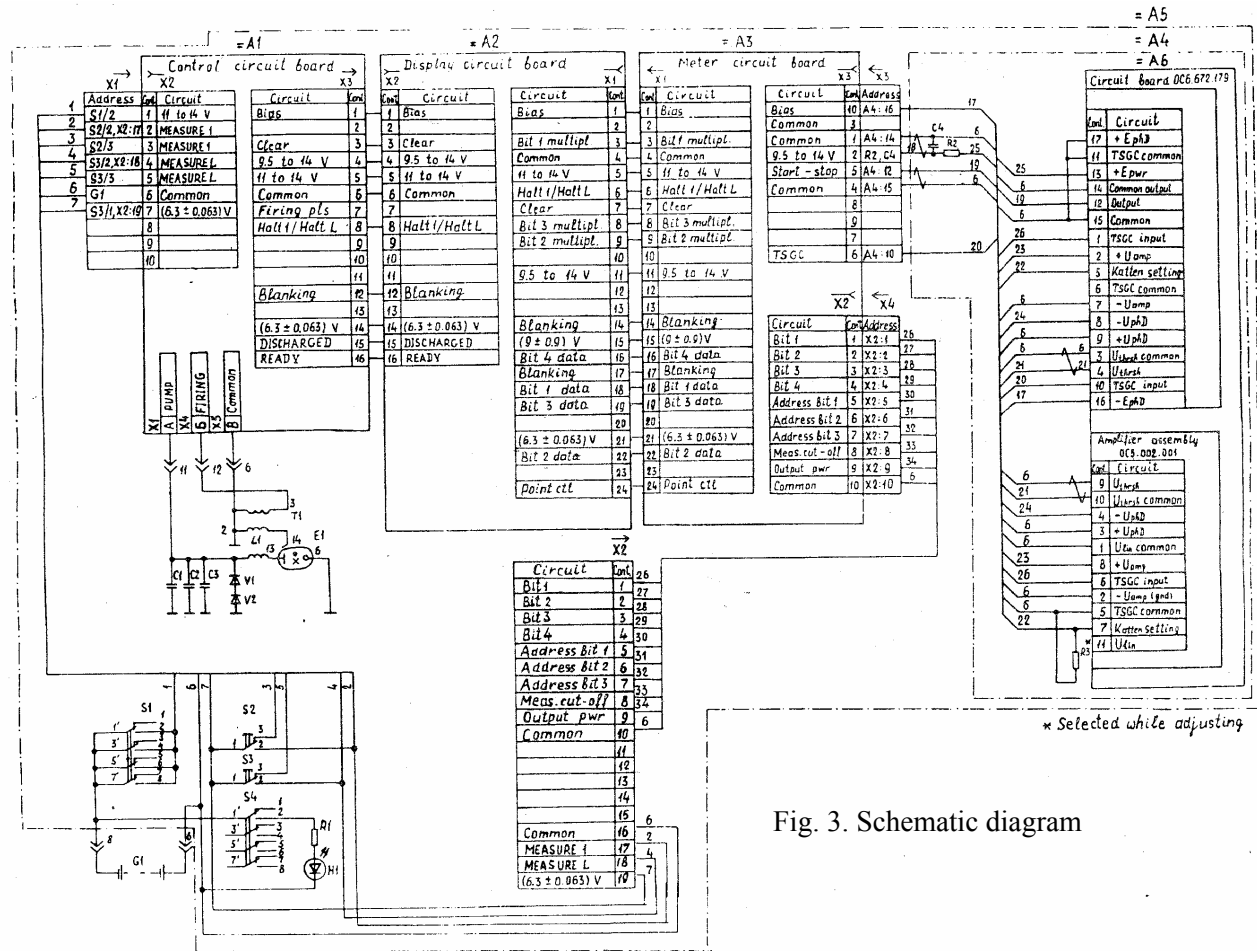

Fig. 3. Schematic diagram

\* Selected while adjusting