

# PZM-20R<sup>®</sup>

# PZM-20RW

The Crown<sup>®</sup> PZM-20R is a Pressure Zone Microphone<sup>®</sup> designed for permanent flush-mounting in tables, lecterns, pulpits, and judicial benches. Its unobtrusive appearance and hemispherical pickup pattern make it ideal for conference table use. The microphone fits into a 4.59-in. (11.659-cm) square hole or in a standard 4.0-in. x 4.0-in. (10.16-cm x 10.16-cm) electrical outlet box.

Electronics in the base of the 20R adapt the microphone for phantom powering. No external power-supply interface is required. The microphone plugs directly into a phantom power supply providing 12 to 48 volts.

The wide-range frequency response of the 20R is emphasized at high frequencies for clarity and articulation. Low frequencies below the voice range are filtered out to reduce rumble.

Three small guard-posts prevent papers from sliding underneath the cantilever arm and altering the frequency response.

Like other Pressure Zone Microphones, the 20R utilizes the Pressure Recording Process<sup>™</sup> in which a miniature condenser microphone capsule is arranged very close to a sound-reflecting plate or boundary. The capsule is mounted in the "Pressure Zone" just above the boundary, a region where sound coming directly from the sound source combines in-phase with sound reflected off the boundary. The benefits are a wide, smooth frequency response free of phase interference, excellent clarity and "reach," a hemispherical polar pattern, and uncolored off-axis response.

### Suggestions For Use

The PZM-20R differs from other PZMs in that it is a stationary microphone, generally not moved from one location to another. Before installing it, first check that the pickup will be adequate by testing a regular PZM placed where you plan to install the 20R.

Avoid areas where items might be placed on top of the microphone. Once you've decided on the microphone position, rout a recessed hole according to the dimensions in Fig. 2B on the reverse side.

## PRESSURE ZONE MICROPHONE



### Features

- For permanent flush-mounting in tables
- Hemispherical polar pattern picks up everyone around the microphone
- Frequency response tailored for speech clarity
- Low-frequency rolloff reduces air-handling noise
- Screw terminals provide low-cost connections

### Specifications

**Type:** Pressure Zone Microphone.

**Element:** Electret condenser.

**Frequency response (typical):** 80 Hz to 20 kHz (see Fig. 1).

**Polar pattern:** Hemispherical on an infinite plane.

**Open circuit sensitivity:** 7 mV/Pa\* (-43 dB re 1 volt/Pa).

**Power sensitivity:** -43 dB re 1 mW/Pa. EIA sensitivity -135 dBm.

**Impedance:** 240 ohms balanced. Recommended minimum load impedance 1000 ohms.

**Equivalent noise level:** 20 dB SPL (0 dB = 0.0002 dyne/cm<sup>2</sup>), A-weighted.

**S/N ratio:** 74 dB at 94 dB SPL.

**Maximum SPL:** 150 dB SPL at the microphone produces 3% THD.

**Polarity:** Positive pressure on the diaphragm produces positive voltage on terminal 2 with respect to terminal 3 of the output terminal strip.

**Operating voltage:** Phantom power, 12 to 48 volts DC, positive voltage on terminals 2 and 3 with respect to terminal 1 of the output terminal strip.

**Current drain:** 1.1 mA.

**Color:** Black.

**Connector:** Screw terminals. #1 shield, #2 audio in-polarity, #3 audio return.

**Cable:** None supplied; use 2-conductor shielded microphone cable.

**Weight:** 8.1 ounces (230 grams).

**Dimensions:** See Figs. 2A and 2B.

**Optional accessories:** Crown PH-1A phantom power supply (single channel, battery or AC adapter powered).

Fig. 1

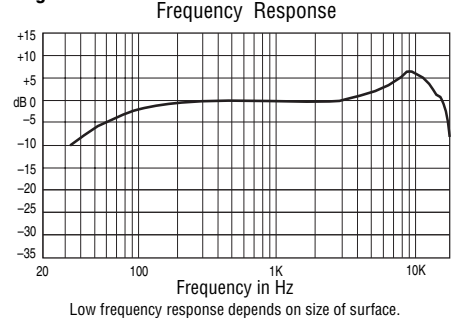
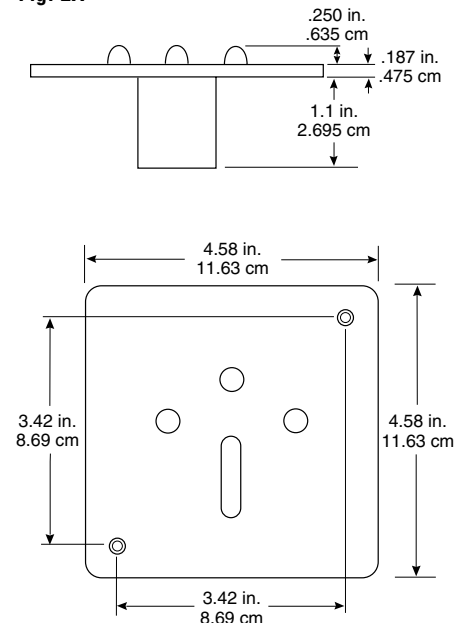

Fig. 2A



\*1 pascal = 10 dynes/cm<sup>2</sup> = 10 microbars = 94 dB SPL.



INSTALLED

# PZM-20R PZM-20RW

Fig. 2B

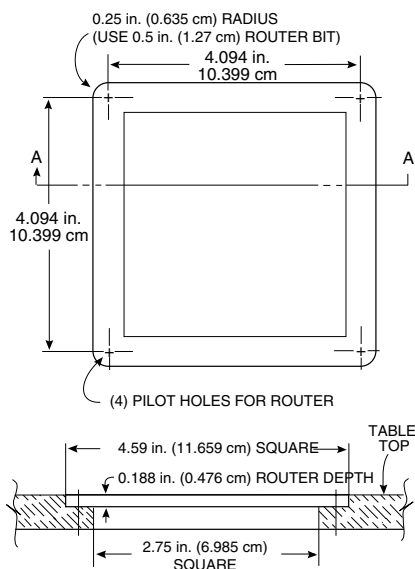

For small conference tables seating up to eight people, mount the 20R in the center of the table. For larger tables, use one 20R in the middle of every four to six people. Ideally no person should be more than 3 feet from the nearest microphone. For maximum clarity hold the conference in an acoustically "dead" room with carpeting, acoustic-tile ceiling and drapes.

## Operating Instructions

Using two-conductor shielded microphone cable, connect the output of the 20R to a mixer microphone input that provides 12-48 volts phantom powering. This cable may be of any length because the microphone output is balanced low impedance.

The 20R has three screw terminals. Connect screw #1 to the cable shield, #2 to the audio in-polarity (hot) lead, and #3 to the audio cold lead. On the equipment end of the cable, solder the cable to the XLR-type connector as follows: pin 1: shield, pin 2: audio in-polarity (hot) lead, pin 3: audio cold lead.

If your mixer or recorder does not provide phantom powering, you'll need a microphone power supply. Crown offers a model PH-4B power supply for powering up to four PZMs. Also available is a single channel AC/battery supply, Crown model PH-1A. Connect the 20R output to the power-supply input; connect the power-supply output to your recorder or mixer mix input.

## Architects' and Engineers' Specifications

The microphone shall be the Crown Model PZM-20R or equivalent. The microphone shall be a Pressure Zone, electret condenser type, designed for permanent flush-mounting in a 4.59-in. (11.659-cm) square hole or in a standard 4.0-in. x 4.0-in. (10.16-cm x 10.16-cm) electrical outlet box. A smooth

frequency response from 80 Hz to 20,000 Hz shall be obtained. The microphone shall have a sensitivity of -43 dBV/Pa (measured on an infinite boundary). The microphone shall accept a 150 dB SPL input while producing no more than 3% THD (open-circuit termination). Equivalent noise shall be typically 20 dBA (0 dB = .0002 dyne/cm<sup>2</sup>). The Crown model PZM-20R is specified.

## Warranty

Crown professional microphones are guaranteed against malfunction for a period of three years from date of original purchase. Please refer to the enclosed full warranty sheet for more detail.

## Service

If the microphone does not function properly, replace or repair mic cables and connectors, check the power supply. If it is determined that the microphone needs service and you want to return it to Crown, a Service Return Authorization (SRA) is required. An SRA can be completed online at [www.crownaudio.com/support/factserv.htm](http://www.crownaudio.com/support/factserv.htm). After securing an SRA, return the microphone in its original packaging to: **Crown Factory Service, 1718 West Mishawaka Road, Elkhart, Indiana 46517-9439**. For further assistance or technical support call **800-342-6939**.



H A Harman International Company

Crown International, Inc.  
1718 W. Mishawaka Rd.  
Elkhart, IN 46517-9439  
TEL: 574-294-8000  
FAX: 574-294-8FAX  
[www.crownaudio.com](http://www.crownaudio.com)

©2005 Crown Audio®, Inc. Specifications subject to change without prior notice. Latest information available at [www.crownaudio.com](http://www.crownaudio.com). Crown, Crown Audio, PZM and Pressure Zone Microphone are registered trademarks of Crown International. Pressure Recording Process is a trademark of E. M. Long Associates.