



MB-1 MB-1AL

The Crown® MB-1 is a miniature boundary microphone for multi-miking applications such as teleconferencing, distance learning, boardrooms, and courtrooms.

A low-profile circular microphone, the MB-1 has a bottom-mounted phone plug. Supplied with the mic is a table insert with a phone jack that accepts the mic. The insert flush-mounts in a hole drilled in the table. After meetings, the mic can be removed and the insert covered with the provided disk.

Thanks to its half-supercardioid pickup pattern, the MB-1 greatly reduces ambient noise and pickup of room reverberation. The result is a clearer sound.

The MB-1 must be used with an MB-100 interface (not included). The interface performs these functions:

- Powers and equalizes up to four mics
- Provides programmable switching to turn the mic on or off if desired (switches not provided).
- Pluggable microphone inputs
- Provides balanced outputs from the interface

MB-1 Features

- Painted removable grille assembly
- Miniature mic plugs into jack in table insert
- Clean, clear, natural sound
- Low-Z balanced output prevents hum and high-frequency loss
- Defeatable LED
- Choice of insert finishes:
Black anodized (MB-1).
Paintable aluminum (MB-1AL)

How to Paint the Microphone

1. Using a small screwdriver, pry open one side of the base, then the other side (Fig. 5).
2. Remove foam liner.
3. Wearing a dust mask, spray-paint the grille assembly. Be sure grille holes are not clogged.
4. Allow paint to completely dry.
5. Make sure the LED is properly aligned.
6. Carefully place the grille assembly over the LED, and snap in place.

MINI-BOUNDARY™ MICROPHONE



Features

- Perfect for multimiking applications in teleconferencing, distance learning, boardrooms and courtrooms
- Phase Coherent Cardioid® design prevents coloration from surface sound reflections
- Half-supercardioid polar pattern reduces ambient noise and room reverberation
- Very small and inconspicuous
- Mic plugs into an insert in the table

Specifications

All specs apply to each output of the interface with a mic connected.

Type: Phase Coherent Cardioid.

Element: Electret condenser.

Frequency response (typical): 50 Hz to 15,000 Hz at 30 degrees incidence to surface (see Fig. 1).

Polar pattern: Half-supercardioid (supercardioid in the hemisphere above the primary boundary). See Figs. 2 and 3.

Impedance: 150 ohms, balanced. Recommended load impedance 1000 ohms or greater.

Open-circuit sensitivity (typical): 22 mV/Pa* (-33 dB re 1 volt/Pa).

Power sensitivity: -30.5 dB re 1 mW/Pa.* EIA rating -125 dBm.

Equivalent noise level (self-noise): 22 dB SPL typical (0 dB=0.0002 dyne/cm², A-weighted).

S/N ratio: 72 dB at 94 dB SPL.

Maximum SPL: 120 dB SPL at 3% THD.

Polarity: Positive (inward) pressure on the diaphragm produces positive voltage on interface output terminal 1 with respect to terminal 3, and on terminal 4 with respect to terminal 6.

Operating voltage (interface): 18-48V phantom power.

Current drain: 5 mA nominal with LED on, 4 mA nominal with LED off.

Operating temperature range: -10° to +50° C, or +14° to +122° F.

Mic connector: Stereo phone plug. Mates with stereo phone jack in supplied insert.

Cable connectors (supplied with MB-100 interface):

- Two pluggable terminal blocks (PTBs) in line with the microphones. Each input connector handles up to two mics.
- Two PTBs for output connectors to your mixer. Each output connector feeds two mixer mic inputs.
- Two PTBs for remote switch sensing. Each PTB connects to two remote switch sensors.

Cable: None supplied. Use two-conductor shielded mic cable between phone jack and pluggable terminal block. Use two-conductor shielded mic cable between interface output and mixer input. Use twisted-pair cable between each user switch and interface.

Materials: High-impact molded plastic and steel mesh mic grille, steel chassis.

Insert Finish: MB-1: black anodized, MB-1AL: aluminum.

Net weight: Microphone: 0.7 ounces (19.8 grams).
Table insert: 3.9 ounces (109 grams).

Dimensions: See Figs. 4a and 4b.

Included accessories: Table insert with stereo phone jack. Disk to cover insert when mic is removed.

*1 pascal = 10 dynes/cm² = 10 microbars = 94 dB SPL.

Fig. 1

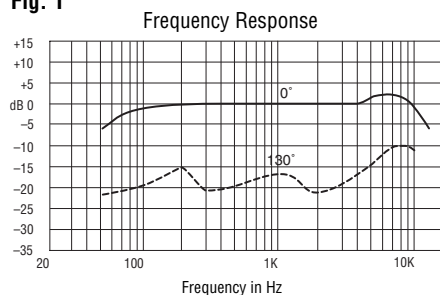
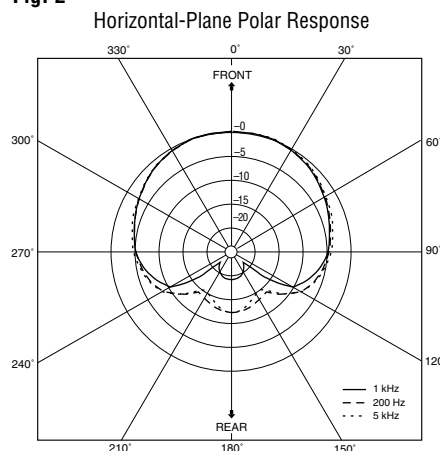

Fig. 2





INSTALLED

MB-1 MB-1AL

Fig. 3

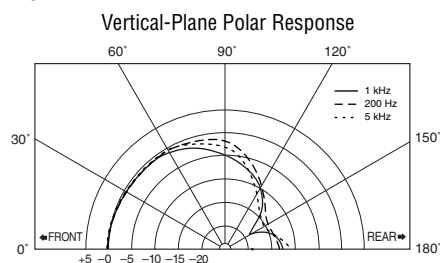

Fig. 5

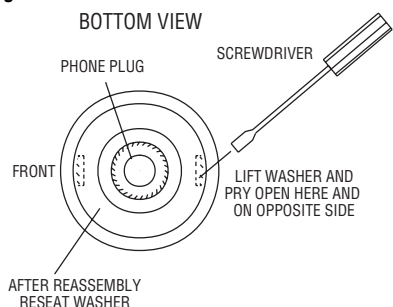

Fig. 4a

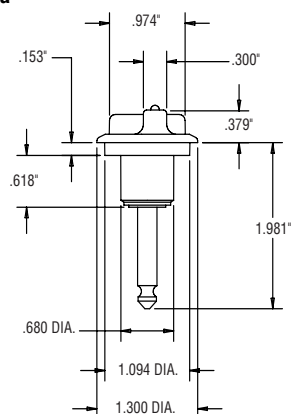
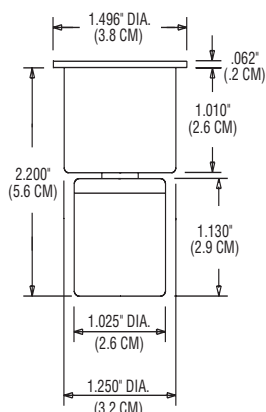

Fig. 4b



Installation

1. If the microphone will be used on a lectern, install it on an open surface. Do not install in a cavity or recessed area as the frequency response and polar pattern will be degraded.
2. Drill a hole 1.25-in. (3.175-cm) diameter for each mic's insert.
3. When you install the insert, make sure that the locating pin for the microphone is facing in the desired direction. Orient the mic so the word "Crown" is readable by the user (right-side-up).
4. Wire the mic to the MB-100 interface as described in the interface data sheet.
5. Plug each mic into its jack. The front of the mic is indicated by the Crown logo on the microphone.
6. After use, you may remove the mics and cover their inserts with the supplied disks.

Architects' and Engineers' Specifications

The microphone shall be the Crown model MB-1 or equivalent. The microphone shall be a half-supercardioid electret condenser type. The microphone shall use the principle of phase coherency achieved by mounting a small-diameter element very near a boundary. This eliminates comb filtering in the audible spectrum.

The microphone shall exhibit excellent off-axis response and gain-before-feedback. Each mic shall have a bottom-mounted stereo phone plug.

A table insert with phone jack shall be included. The mic shall be used with a pluggable terminal block and an MB-100 interface (not included). The interface shall provide operating voltage to each microphone, and convert its output signal to low-impedance balanced.

Nominal sensitivity shall be 22 mV/Pa. Maximum SPL shall be 120 dB SPL for 3% THD. Equivalent noise shall be 22 dBA nominal. Frequency response shall be 50 Hz to 15 kHz with a uniform off-axis response, about 20 dB down at the rear nulls.

The Crown models MB-1 and MB-1AL are specified.

Warranty

Crown professional microphone products are guaranteed against malfunction for a period of three years from date of original purchase. See enclosed warranty sheet for additional information.

Service

If the microphone does not function properly, check that it is aimed correctly and is configured and connected as described in the MB-100 interface data sheet. Check the slide-switch setting in the interface. If there is hum or no signal, first repair or replace the cable.

If it is determined that the microphone needs additional service and you wish to return it to Crown, a Service Return Authorization (SRA) is required. An SRA can be completed online at www.crownaudio.com/support/factserv.htm. After securing an SRA, return the microphone in its original packaging to: **Crown Factory Service, 1718 W. Mishawaka Road, Elkhart, IN 46517-9439.**

For further assistance or technical support call **800-342-6939.**



H A Harman International Company

Crown International, Inc.
1718 W. Mishawaka Rd.
Elkhart, IN 46517-9439
TEL: 574-294-8000
FAX: 574-294-8FAX
www.crownaudio.com

©2008 Crown Audio®, Inc. Specifications subject to change without prior notice. Latest information available at www.crownaudio.com. Mini-Boundary is a trademark, and Crown and Crown Audio are registered trademarks of Crown International.