



CM-311A CM-311AE

Designed for touring and live-sound applications, the Crown® CM-311A is a rugged head-worn microphone with unequalled performance. It sounds like the best handheld microphones—full, clear, and distortion-free, even with the loudest singers.

The CM-311A is the latest version of the Crown's proprietary Differoid® technology. Its cardioid pickup pattern rejects sounds from the rear, such as floor monitors. Its noise-canceling ability rejects sounds at a distance, such as instruments on stage and crowd noise. This results in the CM-311A having outstanding gain-before-feedback and isolation.

Lightweight and comfortable, the mic's headband and boom adjust to fit any singer. An included pop filter greatly reduces breath noise and pops. Because of the boom's unique behind-the-ear design, it does not cover up the singer's face.

Two models are available: CM-311A and CM-311AE. The CM-311A is powered by a 9V battery or phantom power. It has a battery belt pack with an on/off switch, a programmable mic on/off switch, and a "Mic On" LED. The CM-311AE is a pig-tail version allowing you to connect it to most wireless transmitters.

NOTE: Putting an XLR connector on the CM-311AE and connecting to a mic input with phantom power WILL damage the mic element. For wired applications, use the CM-311A.

How to adjust for best fit and to prevent boom bounce

Note: To get the maximum performance out of this microphone, take the time to adjust it to fit correctly.

For best results, the CM-311A MUST be custom fitted to a single user's head. This simple procedure takes only a few minutes. Please refer to Fig. 5 and locate the parts described.

1. If the microphone is for yourself, we suggest that you use a mirror to double check the fit as you make adjustments.
2. Loosen (just a little) the thumbscrew located on the outside of the foam block, part way back on the boom. This allows the boom to slide in and out, and to rotate left and right.
3. Now bend the headband wire to fit your head. Put the foam-block wire behind your ear. Then you can bend the earpieces to fit snugly around your ears. The back of the headband should fit firmly against the back of your neck.

DIFFEROID HEAD-WORN CONDENSER MICROPHONE

Features

- Full, clear, distortion-free sound
- Outstanding gain-before-feedback and isolation
- CM-311A has battery/phantom belt pack
- CM-311AE connects to most wireless transmitters



Specifications

Transducer type: Electret condenser.

Frequency response (typical): 50 Hz to 17,000 Hz (see Fig. 1).

Polar pattern: Cardioid (see Fig. 2).

Impedance: CM-311A, 75 ohms balanced. CM-311AE, 6 kilohms unbalanced.

Recommended load impedance: CM-311A, 1000 ohms or greater. CM-311AE, 10 kilohms.

Open-circuit sensitivity, typical, close-talking: CM-311A, 4 mV/Pa* (-48 dB re 1V/Pa), CM-311AE, 1.25 mV/Pa (-58 dB re 1V/Pa).

Power sensitivity, typical, close-talking: CM-311A: -42.5 dB re 1 mW/Pa*, CM-311AE: -71.5 dB re 1 mW/Pa.

Equivalent noise level (self noise): 26 dB SPL typical (0 dB = 0.0002 dyne/cm²), A-weighted.

S/N ratio: 68 dB at 94 dB SPL.

Maximum SPL: CM-311A, 148 dB SPL produces 3% THD. CM-311AE, 140 dB SPL with 3V DC, 148 dB SPL with 9V DC.

Operating voltage: CM-311A, 9V DC internal alkaline battery or 18-48V phantom power. CM-311AE, 3-9V DC from the transmitter's battery.

Polarity: Positive pressure on diaphragm produces positive voltage on CM-311A XLR pin 2 with respect to pin 3, and on CM-311AE shield with respect to white lead.

Current drain: CM-311A, 6.5 mA nominal. CM-311AE, 0.27 mA nominal.

Battery life: CM-311A, 85 hours. CM-311AE, approximately equal to transmitter battery life.

Operating temperature range: -10° to +50° C, or -14° to +122° F.

Off-attenuation: 70 dB.

Output connectors: CM-311A, 3-pin pro audio (XLR type). CM-311AE, supply your own to match your transmitter.

Cables (CM-311A): 2-conductor shielded, unbalanced cable, 42-inches (106.68 cm) from headband to battery pack. Use 2-conductor shielded mic cable (not included) between XLR connector and mixer mic input.

Cable (CM-311AE): In-line with this cable is a small circuit module that equalizes the microphone signal. Cable is 42-inches (106.68 cm) long from headband to module, 12-inches (30.48 cm) from module to cable end. 2-conductor shielded unbalanced cable, unterminated.

Materials: High-impact plastic mic housing, brass boom, steel wire headband, high-impact plastic and steel battery pack.

Finish: Satin black.

Net weight: Head-worn mic, 2.1 oz (61 g). CM-311A belt pack and battery, 6.1 oz (173g).

Dimensions: Headband 5.5-in. (13.97 cm) diameter, adjustable. Boom approximately 7 in. (17.78 cm) x 3 in. (7.62 cm). See Figs. 3 and 4.

Included accessories: Microphone carrying case, WS-6 foam pop filter, clothing clip.

Optional accessories: PH-1A phantom power supply (1 channel, AC-adaptor powered). WS-14 accessory windscreen.

*1 pascal = 10 dynes/cm² = 10 microbars = 94 dB

Fig. 1

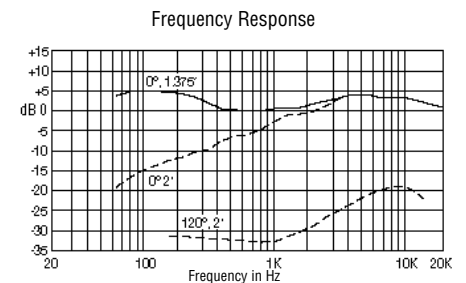

Fig. 2

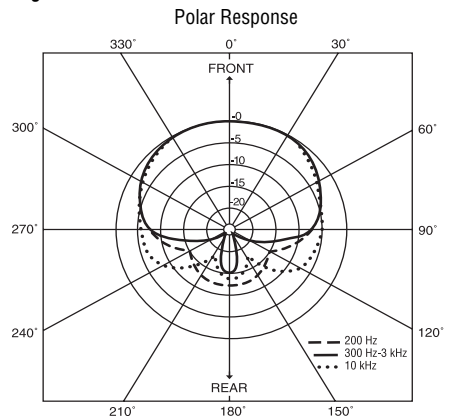
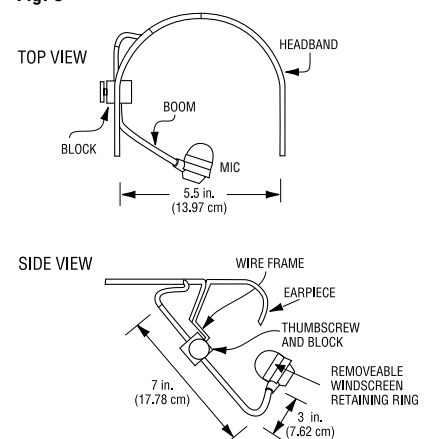

Fig. 3





CM-311A CM-311AE

Fig. 4

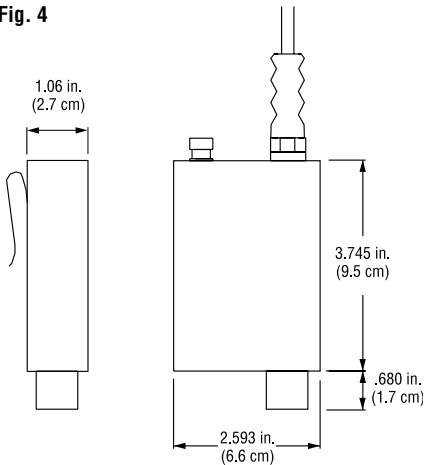
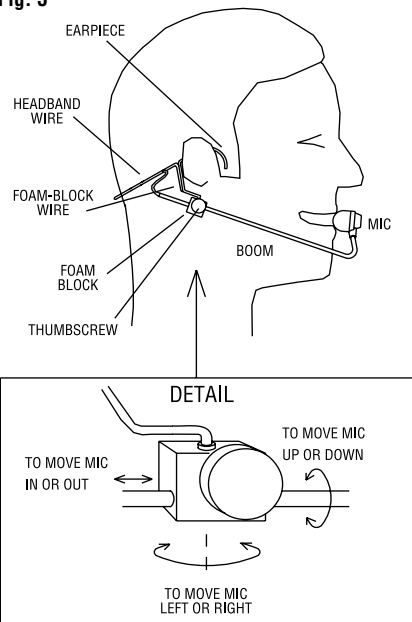

Fig. 5



Note: For users with petite heads, extra headband material may have to be cut off to get the headband to fit properly.

- Next, adjust the foam pad snug against your head or neck. To do this, bend the wire that goes into the foam block. **CAUTION! Do not bend the boom itself — just the foam-block wire.** A snug fit of the foam pad prevents boom bounce when you move around.
- Be sure that the thumbscrew is still loosened a little. Move the boom in or out, and left or right, to center the mic directly in front of your lips. **The foam pop filter should press firmly against the lips.** This is necessary because the mic cancels sounds that are not close to it. Also, it keeps the boom from bouncing. Tighten the thumbscrew and you're done.

Once you've adjusted the headset, it should remain in that position -- no further adjustments are needed. You can still swing the mic up or down, away from your lips, if you don't want to be heard on the P.A. — or use the mic on/off switch programmed for "press off" operation.

After several hours of use, the foam pop filter can become clogged with moisture, giving a muffled sound. Periodically wash it in mild detergent and water. The foam pop filter is held in place by a removable ring.

Additional WS-6 pop filters can be ordered from Crown's Parts Department.

How to insert a battery in the CM-311A belt pack

- Access the battery by sliding open the battery cover.
- Insert a fresh 9V alkaline battery (Mallory Duracell MN1604 or equivalent) into the battery tray. The battery cover shows the correct polarity.
- Replace the battery cover. To prolong battery life, turn off the battery switch when not in use.

If you're using phantom power, and the battery switch is on, the battery will take over automatically if phantom power fails.

After 85 hours of use, or if the sound is distorted, it's time to replace the battery.

How to program the mic on/off switch

The mic on/off switch can be programmed to work in three ways:

- * Push-on/push-off.
- * Momentary on.
- * Momentary off (as supplied).

To change the switch operation, open the belt-pack case by removing the three screws. Set the switch as shown below:

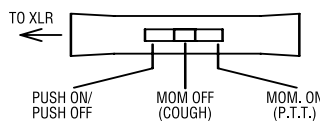

The LED lights when the mic is on.

How to connect the CM-311AE to a wireless transmitter

- Solder on a connector that mates with your transmitter. Technical Bulletin #3 (included) shows the correct wiring for various transmitters. **A wireless transmitter must have separate leads for ground, audio and bias (3-9 volts).**

- Plug in the cable. Adjust the trim pot on the transmitter input to prevent distortion.

Note: Crown has certain models available for wireless transmitters from Shure, AKG, Audio-Technica and Telex. Contact Technical Support for more information at 800-342-6939.

Architects' and Engineers' Specifications

The microphone shall be the Crown Model CM-311A or CM-311AE or equivalent. The microphone shall be a head-worn, noise-cancelling, cardioid type of electret-condenser design. The microphone shall exhibit excellent off-axis response and gain-before-feedback. The microphone shall have an adjustable headband, adjustable boom with locking thumbscrew, and foam pop filter.

Model CM-311A shall include a battery belt pack. Model CM-311AE shall be the head-worn micro-

phone alone. In the CM-311A, a 42-inch, permanently attached, two-conductor shielded cable shall connect the microphone to the belt pack. The belt pack shall include a 3-pin pro audio (XLR type) connector. In the CM-311AE, a 42-inch, permanently attached, two-conductor shielded cable can be connected to a transmitter.

Model CM-311A shall be powered by a 9V battery in the belt pack, or by 18 to 48V phantom power. The belt pack shall have a battery on/off switch, a programmable mic on/off switch, and a "Mic On" LED. Model CM-311AE shall be powered by 3-9V DC from a transmitter.

Nominal open-circuit sensitivity shall be 4 or 1.25 mV/Pa. Maximum SPL shall be 148 dB SPL for 3% THD. Equivalent noise shall be 27 dBA nominal. Frequency response shall be 50 Hz to 17,000 Hz with a uniform off-axis response, over 20 dB down at the rear null. The Crown models CM-311A and CM-311AE are specified.

Microphone Warranty

Crown professional microphones are guaranteed against malfunction for a period of three years from date of original purchase. See enclosed warranty sheet for additional information.

Service

If the microphone does not function properly, check that it is aimed correctly and is connected as described in this datasheet. If the microphone is defective, return it in the original packaging to: **Crown Factory Service, 1718 West Mishawaka Road, Elkhart, IN 46517-9439.**

A Service Return Authorization (SRA) is required for product being sent to the factory for service. An SRA can be completed on line at www.crownaudio.com/support/factserv.htm. For further assistance or technical support call 800-342-6939.



H A Harman International Company

Crown International, Inc.
1718 W. Mishawaka Rd.
Elkhart, IN 46517-9439
TEL: 574-294-8000
FAX: 574-294-8FAX
www.crownaudio.com

© 2008 Crown Audio®, Inc. Specifications subject to change without prior notice. Latest information available at www.crownaudio.com. Crown, Crown Audio and Differoid are registered trademarks of Crown International.