

## Turning the ringer on and off

By default, the ringer is on.

- 1 Press **(set)**
- 2 Press the **PLAY/PAUSE/STOP** button twice  
The Celestia says: 'Ring on' or 'Ring off'.
- 3 Press **(memo)** or **(ogm)** to switch the ringer on or off
- 4 Press **(set)** to save the new setting and leave Settings mode  
OR press **(1)** to leave Settings mode without saving any changes  
OR press **PLAY/PAUSE/STOP** to go back to setting the time and date

## Troubleshooting

The Celestia 400 must be serviced by trained engineers. NEVER attempt any repairs or adjustments yourself — you could make the problem worse and invalidate the Guarantee.

Always make sure your Celestia 400 is fully plugged into the telephone line socket and the mains power socket.

### If the phone does not ring ...

- Check that the ringer volume is not set to -0.
- Check that the total REN value of all equipment connected to your telephone line is no more than 4. Disconnect one or more telephones and see whether that helps.

### If you cannot dial out ...

- Disconnect all other instruments connected to the same line as the Celestia 400 and see whether you can make a call.
- Disconnect the Celestia 400 from the telephone line and plug a telephone into the socket. Try making a call. If this works, the line is OK.
- If you are using a two-way socket adapter, remove it and plug a telephone directly into the socket. If the call now works, the adapter may be faulty.
- If you think the fault may be on the exchange line, contact the service provider (the BT engineers on 151, or your cable company).
- If you still cannot identify the cause of the problem, contact the Binatone Help Line.

### Technical details

Temperature range	Operating 0°C to 40°C Storage -20°C to 60°C
Approvals	CTR 21
Input	230 V AC, 50Hz, AC9 V, 200 mA
Mains adapter part number	XX002104D

The AC port (connected to the mains power supply) is a SELV port with respect to EN41003

### Default settings

Time and date	12:00 am on 01-01
Max. incoming message length	3 minutes
Security code	123
Ring count	2

If the unit is disconnected from the telephone line, all settings will be returned to these defaults.

Binatone Telecom plc operates a policy of continuous product improvement, and so reserves the right to make changes to the product and functions without notice.

**If you need help, call the Binatone Help Line**  
**020 8344 8870**  
 9.00 am to 5.00 pm, Monday to Friday



## USER GUIDE

Model 3401

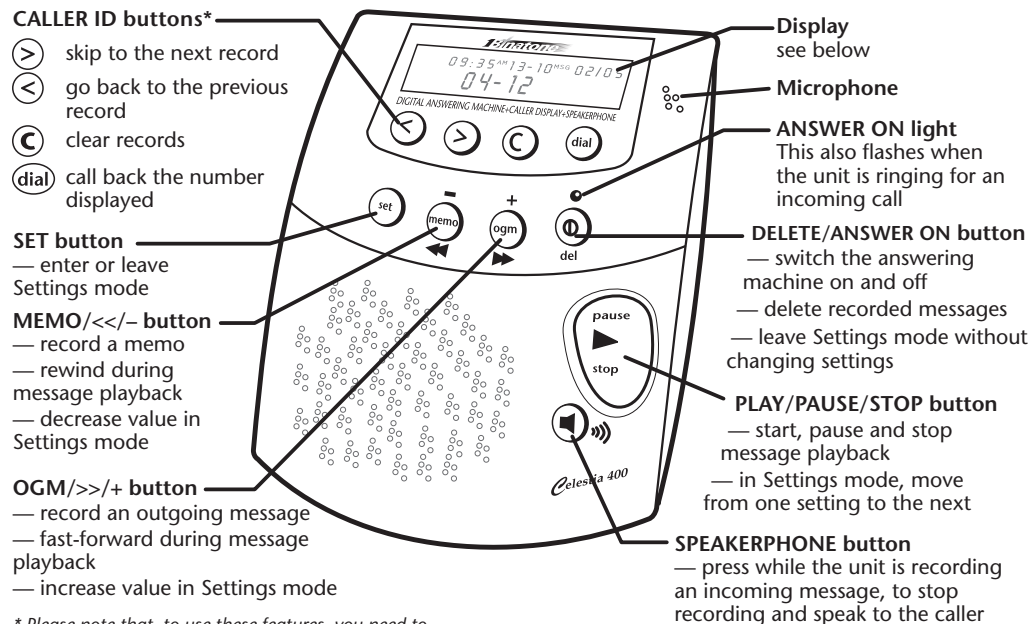

\* Please note that, to use these features, you need to subscribe to the BT Caller ID option, or the equivalent option from your service provider.

The (>) and (<) buttons can also be used to adjust the speaker and ringer volumes (see page 7)

## The display

While the Celestia 400 is idle, the display shows information as in this example:

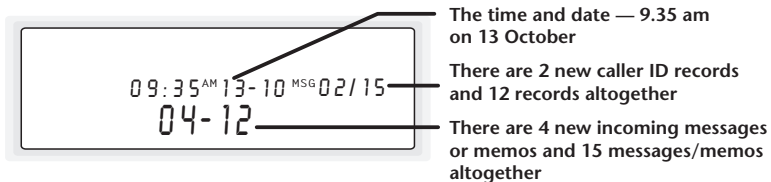

Other information and symbols that appear on the display include:

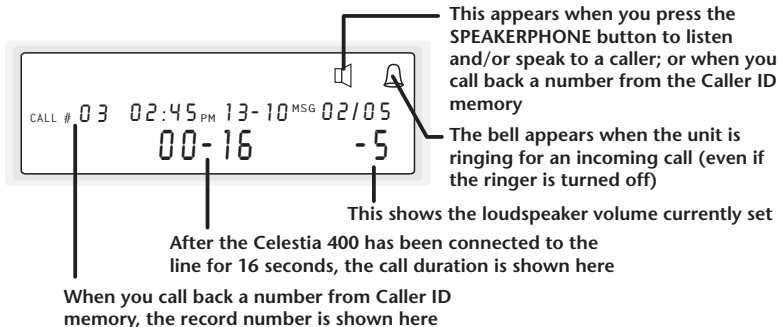

## Installation

You need to have a telephone connected to your line as well as your Celestia 400. If you wish to connect both units to the same telephone line socket, use a two-way adapter ('splitter') widely available from retailers.

Alternatively, you can connect the phone and the Celestia 400 to different extension sockets.

The Celestia 400 should be installed where the mains power cable will reach a 230V AC, 50 Hz switched socket. NEVER try to lengthen the mains power cable.

You can either wall mount the unit, using the template supplied, or stand it on a flat surface. If you leave the unit free-standing, you can fit the support stand as shown, for the best position, or in the front slot.

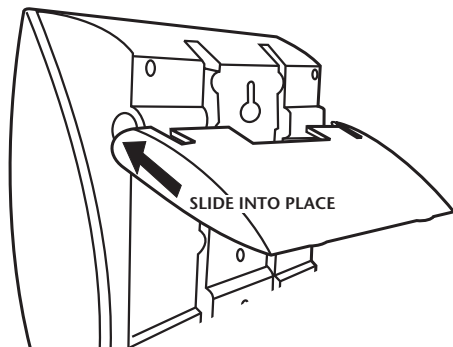

(If you prefer to have the unit standing upright, slide the support stand into the lower slot, rather than as shown.)

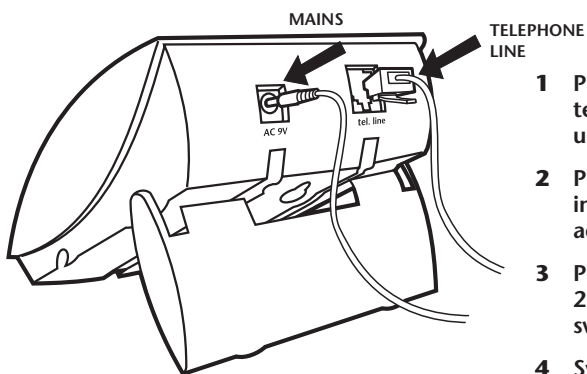

- 1 Plug the mains power lead and the telephone line cord into the back of the unit as shown
- 2 Plug the telephone line cable directly into the socket or into the two-way adapter (see note above)
- 3 Plug the mains adapter into a 230 V AC, 50 Hz mains socket, with the switch on the socket set to OFF
- 4 Switch on power at the mains socket

The Celestia 400 must be used with mains adapter, part no. XX002104D, supplied with the unit. Using any other adapter will result in non-compliance with EN41003, and will invalidate any approval given to this apparatus.

Do not clean any part of your Celestia 400 with solvent chemicals, abrasives or spray cleaners which might get inside the case and cause damage not covered by the guarantee. When necessary, clean it with a damp cloth.

Keep your Celestia 400 away from hot, humid conditions or strong sunlight.

### Conditions for use

You can connect the Celestia 400 to a public exchange line in the UK. It is not suitable for connection to a PBX.

The ringer equivalence numbers (RENs) of all instruments connected to an exchange line must not add up to more than 4. The Celestia 400 has a REN of 1; most other phones and fax machines have a REN of 1 unless marked otherwise.

NOTE: if you disconnect the Celestia 400 from mains power, your time and date settings will be lost. However, stored messages and Caller ID records will be retained.

**SAFETY WARNING**  
Do not install the Celestia 400 where it might get wet

To set the time and date, and the number of rings before the Celestia 400 will answer a call, refer to SETTINGS on pages 6 to 8.

## Recording your outgoing message

- 1 Press and hold **ogm** until you hear a 'beep'
- 2 Speak clearly into the microphone  
Your outgoing message (OGM) can be between 3 and 60 seconds long. The display shows the recording time as you speak. Do not pause for more than 10 seconds.
- 3 Press the **PLAY/PAUSE/STOP** button when you have finished speaking  
The machine will 'beep' then play back your OGM.

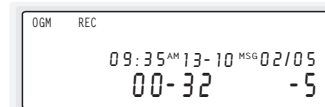

To check your OGM at any time

- Press **ogm**

## Recording a memo

- 1 Press and hold **memo** until you hear a 'beep'
- 2 Speak clearly into the microphone
- 3 Press the **PLAY/PAUSE/STOP** button when you have finished speaking  
Your memo will be stored as a new message.

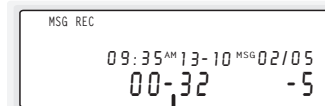

This shows the duration of recording

## Switching the machine on and off

- ▶ Press **1** once — the machine says: 'Answer on' and the light comes on
- ▶ Press **1** again to switch the machine off

## Incoming calls

When a call comes in, the caller's ID is shown on the display (if you subscribe to the Caller ID service or equivalent).

### To answer an incoming call

- ▶ Press **1** while the phone is ringing  
You can converse with the caller in hands-free mode. Remember to speak clearly into the microphone

### To intercept a call

You can intercept a call which the machine has answered.

- ▶ Press **1** while the OGM is playing or while the caller is speaking  
The machine stops recording the caller's message, and you can converse with the caller.

NOTE: if you lift the handset of any phone connected to the same line as the Celestia 400, the machine will stop what it's doing and free the line for you to speak to the caller.

When the OGM is playing to the caller, this appears

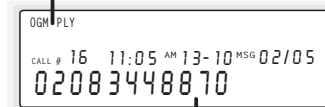

The caller's ID (phone number)



If the caller's ID is unavailable (e.g. on an international call) 'UNAVAILABLE' is shown; if the caller has withheld their ID by dialling 1470, 'WITHHELD' is shown.

## Message playback

- Press the PLAY/PAUSE/STOP button once to start message playback. If you have new messages and memos, the machine plays them. If you have no new messages, the machine plays all messages and memos.



### To pause during playback

- Press the PLAY/PAUSE/STOP button once

### To continue playback

- Press the PLAY/PAUSE/STOP button again

### To skip forward to the next message

- Press

### To skip back to the previous message

- Press

### To stop playback

- Press and hold the PLAY/PAUSE/STOP button

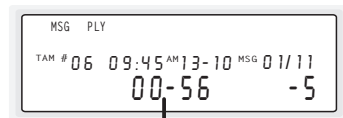

This shows the duration of playback

## Deleting messages

Remember to delete messages after you have listened to them — otherwise, the machine's memory may become full and it will not record any more messages. The machine will not delete new messages.

### To delete a message during playback

- Press once while the message is playing

### To delete all messages

- Press and hold

The machine will delete all old messages and give a confirmation 'beep'. If there are new messages, or no messages to delete, the machine will give an error tone.

## Remote operation

To set your security code for remote operation, refer to page 7.

Refer to the Remote Operation card for details of how to phone in from elsewhere and check whether you have messages.

Note that, if the answering machine is turned off, the Celestia 400 will answer calls after 16 rings, but it will not record messages unless you turn it on using your remote security code.

**During remote operation, the Celestia 400 will pause playback and 'beep' after 3 minutes. Press any key within 10 seconds to continue message playback; otherwise, your call will be cut off.**

## Checking Caller ID records

Up to 50 Caller ID records are stored in the Celestia 400's memory. When the Caller ID memories are full, new records will overwrite the oldest ones. Caller ID records are shown on the display as described on page 1. As you check each new record, it is added to the 'old record' count.

- Press or to display the first record

- Press or to scroll through the list of records

If you come to a record where the caller's ID was unavailable or withheld, you hear a 'beep' and the display shows 'UNAVAILABLE' or 'WITHHELD'.

## Returning a call

- Press or until the number you want is shown on the display
- Press to dial the number

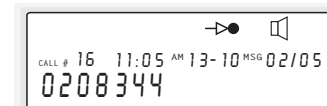

## Deleting Caller ID records

### To delete records one by one

- Press or until the number you want is shown on the display
- Press once to delete the record

### To delete all records

- Press and hold . The machine will delete all old records and give a confirmation 'beep'. If there are no records to delete, the machine will give an error tone.

## Guarantee and service

The Binatone Celestia 400 is guaranteed for 12 months from the date of purchase shown on your sales receipt. The Guarantee does not cover damage by misuse or negligence, or by excessive voltages—for example, faults on the telephone line, or lightning.

### While the unit is under Guarantee

Disconnect the plugs from the mains and the telephone line, then pack up your Celestia 400, using the original packaging. Return the unit to the shop where you bought it, **making sure you take your sales receipt as proof of purchase.**

In the unlikely event that you need to return your Celestia 400 to our Repair Centre while it is under guarantee, there will be a £5 handling charge.

### Repair after the Guarantee has expired

Disconnect and pack up your Celestia 400 as above. Call our Service Department on **01325 304473** and ask for details of the repair charge and the address to send the unit.

Return your Celestia 400 to the address given, remembering to include your name and address, plus a cheque or postal order for the value of the repair charge.

To go into Settings mode, press the **SET** button. Then pressing the **PLAY/PAUSE/STOP** button takes you through a number of options, as shown:

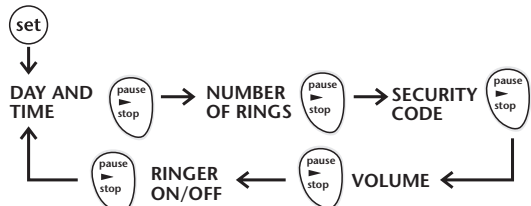

IN SETTINGS MODE, PRESS

- + memo or ogm to change the value of the current setting, step by step. Wait for a prompt between each key press.
- set to leave Settings mode, saving any changes you have made
- 1 to leave Settings mode without saving any changes

## Setting the time and date

*This is OPTIONAL — if you do not set the time and date, the Celestia 400 will automatically take its settings from the network when it answers a call.*

- 1 Press set — the Celestia says: ‘Set day and time’
- 2 Press memo or ogm to change the hour setting (01 to 12)  
Each time you press the button, you change the value by one hour; the Celestia speaks the number. When you reach the correct setting, move to the next step ...
- 3 Press the **PLAY/PAUSE/STOP** button
- 4 Press memo or ogm to change the minute setting (00 to 59). Press **PLAY/PAUSE/STOP**
- 5 Press memo or ogm to switch between am and pm. Press **PLAY/PAUSE/STOP**
- 6 Press memo or ogm to change the date setting (01 to 31). Press **PLAY/PAUSE/STOP**
- 7 Press memo or ogm to change the month setting (01 to 12). Press **PLAY/PAUSE/STOP**
- 8 Press memo or ogm to change the day setting (Monday to Sunday)
- 9 Press set to save the new setting and leave Settings mode  
OR press 1 to leave Settings mode without saving any changes  
OR press **PLAY/PAUSE/STOP** to move on to setting the number of rings

## Setting the number of rings

*This is the number of rings before the Celestia 400 will answer a call when the answering machine is switched on.*

- 1 Press set then **PLAY/PAUSE/STOP** — the Celestia says: ‘Set number of rings’.
- 2 Press memo or ogm to change the number of rings (2 to 9 and TS\*)
- 3 Press set to save the new setting and leave Settings mode  
OR press 1 to leave Settings mode without saving any changes  
OR press **PLAY/PAUSE/STOP** to move on to setting the security code



\* TS is Toll Saver, which saves you paying for an unnecessary call if you dial in to check your messages remotely. If there are new messages, the Celestia will answer your call after two rings; if there are no new messages, it will answer after four rings.

## Setting the security code

*You need a three-digit security code in order to operate the answering machine remotely.*

The default security code is 123. You can change it to any other three-digit code you will easily remember.

- 1 Press set
- 2 Press the **PLAY/PAUSE/STOP** button twice  
The Celestia says: ‘Set security code’.
- 3 Press memo or ogm to set the first digit. Press **PLAY/PAUSE/STOP**
- 4 Press memo or ogm to set the second digit. Press **PLAY/PAUSE/STOP**
- 5 Press memo or ogm to set the third digit. Press **PLAY/PAUSE/STOP**  
The Celestia tells you the security code you have set.
- 6 Press set to save the new setting and leave Settings mode  
OR press 1 to leave Settings mode without saving any changes  
OR press **PLAY/PAUSE/STOP** to move on to setting the security code



## Volume settings

You can adjust the volume of the **loudspeaker** during a call or during message playback by pressing > or <

You can adjust the volume of the **ringer** by pressing > or < while the Celestia 400 is ringing.

The new setting will apply the next time a call comes in.

You can also adjust the volume of the loudspeaker, the ringer and the beeper in Settings mode, as follows.

As you change the beeper and ringer volumes, the Celestia 400 plays a demonstration.

- 1 Press set
- 2 Press the **PLAY/PAUSE/STOP** button three times  
The Celestia says: ‘Monitor on’. The ‘speaker’ symbol appears on the display.
- 3 Press memo or ogm to set the speaker volume. Press **PLAY/PAUSE/STOP**
- 4 Press memo or ogm to set the beeper volume. Press **PLAY/PAUSE/STOP**  
The ‘ringer’ symbol appears on the display.
- 5 Press memo or ogm to set the ringer volume. Press **PLAY/PAUSE/STOP**
- 6 Press set to save the new settings and leave Settings mode  
OR press 1 to leave Settings mode without saving any changes  
OR press **PLAY/PAUSE/STOP** to move on to setting the security code

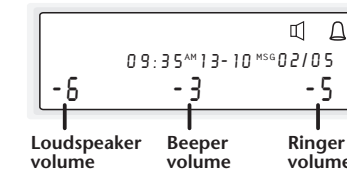

All volumes have a range from 1 to 9, with a default setting of 5.