



- Designed for high-quality sound reinforcement, professional recording and broadcasting
- UniLine™ polar pattern provides narrow 90° acceptance angle
- Superior off-axis rejection for maximum gain before feedback
- UniGuard™ RFI-shielding technology offers outstanding rejection of radio frequency interference (RFI)
- Easy-to-adjust, rugged, small-diameter, alternating gooseneck with virtually no "memory" permits quick positioning into desired shape
- UniSteep® filter provides a steep low-frequency attenuation to improve sound pickup without affecting voice quality

- Self-contained electronics eliminate need for external power module
- Accepts interchangeable elements to permit angle of acceptance from 90° to 360°
- Two-stage foam windscreen yields dramatically improved resistance to P-pops and other breath blasts
- Quick-mount design with 3-pin XLRM-type connector insert at base plugs into any standard XLRF-type surface or cable connector
- Included shock mount attenuates noise, shock and vibration transmitted through the mounting surface

The U857QU stands 19.17" (487.0 mm) from the table or podium; it is also available in a 23.74" (603.0 mm) version as U857QLU. The two models are identical in all other respects.

The U857QU requires 11V to 52V phantom power for operation.

Output from the microphone's XLRM-type connector is low impedance (Lo-Z) balanced. The signal appears across Pins 2 and 3; Pin 1 is ground (shield). Output phase is "Pin 2 hot" – positive acoustic pressure produces positive voltage at Pin 2.

An integral 80 Hz high-pass UniSteep® filter provides easy switching from a flat frequency response to a low-end roll-off. The roll-off position reduces the microphone's sensitivity to popping in close vocal use. It also reduces the pickup of low-frequency ambient noise (such as traffic, air-handling systems, etc.), room reverberation and mechanically coupled vibrations.

Avoid leaving the microphone in the open sun or in areas where temperatures exceed 110° F (43° C) for extended periods. Extremely high humidity should also be avoided.

U857QU/U857QLU SPECIFICATIONS*

ELEMENT	Fixed-charge back plate permanently polarized condenser
POLAR PATTERN	Line Cardioid
FREQUENCY RESPONSE	30-20,000 Hz
LOW FREQUENCY ROLL-OFF	80 Hz, 18 dB/octave
OPEN CIRCUIT SENSITIVITY	-35 dB (17.7 mV) re 1V at 1 Pa*
IMPEDANCE	250 ohms
MAXIMUM INPUT SOUND LEVEL	135 dB SPL, 1 kHz at 1% T.H.D.
DYNAMIC RANGE (typical)	115 dB, 1 kHz at Max SPL
SIGNAL-TO-NOISE RATIO[†]	74 dB, 1 kHz at 1 Pa*
PHANTOM POWER REQUIREMENTS	11-52V DC, 2 mA typical
SWITCH	Flat, roll-off
WEIGHT	
U857QU	5.7 oz (161 g)
U857QLU	5.9 oz (167 g)
DIMENSIONS	
U857QU	19.17" (487.0 mm) long
U857QLU	23.74" (603.0 mm) long
BOTH	0.48" (12.2 mm) head diameter, 0.74" (18.9 mm) base diameter
OUTPUT CONNECTOR	Integral 3-pin XLRM-type
OPTIONAL INTERCHANGEABLE ELEMENTS	UE-C cardioid (120°); UE-H hypercardioid (100°); UE-O omnidirectional (360°)
ACCESSORIES FURNISHED	AT8154 two-stage foam windscreen; AT8662 shock mount

[†]In the interest of standards development, A.T.U.S. offers full details on its test methods to other industry professionals on request.

*1 Pascal = 10 dynes/cm² = 10 microbars = 94 dB SPL

[†]Typical, A-weighted, using Audio Precision System One. Specifications are subject to change without notice.

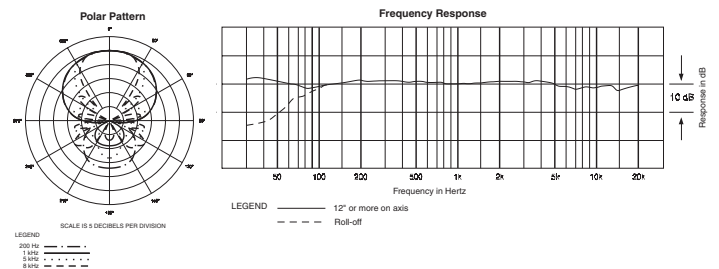

Shock Mount Installation

AT8662 mounting dimensions

- 1/16" (1.5 mm) pilot holes 3 places on 2.29" (58.2 mm) circle.
- 2.0" (51.0 mm) through-hole for mount clearance
- Outside edge of flange, 2.79" (71.0 mm) diameter

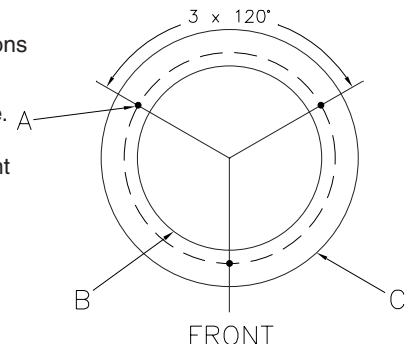

Drawing not actual size.

1. Find the center of the mounting location and mark it. Allow enough clearance to accommodate the shock mount's flange on the surface and make certain there are no physical obstructions below the desired location.
2. Using 2.0" (51.0 mm) hole saw, drill the large through-hole for the shock mount.
3. Set the shock mount into the hole and mark the location of the three mounting screw holes. Make certain to "center" the mount in the large hole before marking the three small mounting screw locations.
4. Using a 1/16" (1.5 mm) drill bit, drill three pilot holes for the mounting screws.
5. After installing the microphone, assure maximum shock mounting effectiveness by providing some slack in the connecting cable.