

# AT4060

## CARDIOID VACUUM TUBE CAPACITOR STUDIO MICROPHONE



### Description

The AT4060 is a cardioid vacuum tube capacitor microphone designed for use in the most demanding studio applications. It utilizes dual, gold-plated and aged, large-diaphragm elements for extended frequency response. The AT4060 has a wide dynamic range of 131 dB and the ability to accept up to 150 dB SPL without capsule or electronic-system distortion above 1% T.H.D. These capabilities, coupled with the benefits of exceptionally low self-noise and very high output, combine in a versatile microphone that meets the diverse requirements of contemporary recording situations, while still providing the warm sound of vintage valve design.

The AT4060 is the culmination of extensive field evaluations in studio environments with resultant significant advances in microphone performance factors. Each hand-selected tube is individually aged and tested, then employed in a uniquely-configured circuit for enhanced tube performance. Specially-tuned elements improve dynamic range and the ability to handle high SPLs without sacrificing high-frequency characteristics. Floating-construction mounting of the elements provides isolation from noise and vibration.

The AT4060 incorporates a dual-diaphragm configuration that allows undistorted reproduction of high sound pressure level signals at all frequencies. The 2-micron-thick, vapor-deposited gold diaphragms provide accurate reproduction of even the most subtle sounds, especially high-frequency signals not easily reproduced by conventional large-diaphragm condenser transducers. For a warm, true-to-life quality, the dual, large-diaphragm design provides remarkable low-frequency performance.

The diaphragm of every AT4060 is aged through five different steps to assure the optimum characteristics achieved will remain constant over years of use.

The symmetrical housing assembly surrounding the microphone capsule and its open acoustical environment allow the off-axis response to be ideally suited for studio work where natural reproduction of off-axis sound is of paramount importance.

The AT4060 operates in conjunction with the included AT8560 power supply. The power supply has low-impedance output (3-pin XLRM-type connector) and a ground-lift switch. Mains voltage (120V or 230V AC) is selectable via a switch on the back of the unit.

The AT4060 includes an AT8447 shock mount to provide mechanical isolation and secure mounting. This effective shock mount fits  $\frac{5}{8}$ "-27 threaded stands. A stand clamp without shock mount, the AT8430, is available as an optional accessory.

### Operation

As with any sophisticated vacuum tube equipment, the AT4060 requires a period of warm-up time before use. Allow at least 15 minutes after switching on the power supply for the unit's electronics to stabilize.

Always turn the power supply off while connecting or disconnecting any cables.

### Architects and Engineers Specifications

The microphone shall be a dual-element vacuum tube capacitor-type with a cardioid polar pattern and a frequency response of 20 Hz to 20,000 Hz. It shall operate from an external AT8560 power supply (included) capable of operating from either 120V or 230V AC. The dual elements shall be internally shock mounted.

Nominal open-circuit output voltage shall be 19.9 mV at 1 kHz, 1 Pascal. The output impedance shall be 200 ohms and output shall be balanced. The microphone shall accept a 150 dB SPL at 1 kHz while producing no greater than 1% T.H.D.

A 32.8' (10 m) cable with 6-pin XLR-type connectors shall be supplied for connection between the microphone and power supply.

The microphone shall have a length of 8.27" (210.0 mm), a maximum body diameter of 2.10" (53.4 mm), and a weight of 22.6 oz (640 grams). Finish shall be matte black. A separate AT8447 shock mount and rack-mount adapters for the power supply shall be included.

The Audio-Technica AT4060 is specified.

# AT4060

## Specifications†

ELEMENTS (TWO)	Externally polarized (DC bias) capacitor
POLAR PATTERN	Cardioid (Unidirectional)
FREQUENCY RESPONSE	20-20,000 Hz
OPEN CIRCUIT SENSITIVITY (1 kHz)	-34 dB (19.9 mV) ± 2 dB, re 1V at 1 Pa* <sup>1</sup>
IMPEDANCE	200 ohms
MAXIMUM INPUT SOUND LEVEL	150 dB SPL, 1 kHz at 1% T.H.D. 149 dB SPL, 1 kHz at 0.5% T.H.D.
NOISE, TYPICAL (A-WEIGHTED) <sup>2</sup>	19 dB SPL
DYNAMIC RANGE, TYPICAL	131 dB, 1 kHz at 150 dB SPL
SIGNAL-TO-NOISE RATIO, TYPICAL	75 dB, 1 kHz at 1 Pa*
POWER REQUIREMENTS	AT8560 power supply (120V/230V AC)
WEIGHT (LESS CABLES)	
Microphone only	22.6 oz (640 grams)
Microphone w/shock mount	33.5 oz (950 grams)
Power supply	4.19 lbs (1.9 kilograms)
DIMENSIONS	
Microphone	8.27" (210.0 mm) long, 2.10" (53.4 mm) maximum body diameter
Power supply	8.27" (210.0 mm) W x 8.86" (225.0 mm) D x 1.73" (44.0 mm) H
ACCESSORIES FURNISHED	AT8560 power supply; AT8447 shock mount for 5/8"-27 threaded stands; 32.8' (10 m) cable with 6-pin XLR-type connectors for use between microphone and power supply; AC power cable; rack-mount adapters for power supply; protective mic carrying case

† In the interest of standards development, A.T.U.S. offers full details on its test methods to other industry professionals on request.

\* 1 Pascal = 10 dynes/cm<sup>2</sup> = 10 microbars = 94 dB SPL

<sup>1</sup> Measured at diaphragm

<sup>2</sup> Using Audio Precision System One

## Optional Accessories:

- AT8137 large cylindrical foam windscreen.
- AT8314 2-conductor, shielded, vinyl-jacketed, broadcast-type cable with XLR-type connector at microphone end, XLRM-type connector at equipment end. Available in 10', 20', 25', 30', 50' & 100' lengths.
- AT8430 stand clamp for 5/8"-27 threaded stands.

### One-Year Limited Warranty

Audio-Technica microphones and accessories purchased in the U.S.A. are warranted for one year from date of purchase by Audio-Technica U.S., Inc. (A.T.U.S.) to be free of defects in materials and workmanship. In event of such defect, product will be repaired promptly without charge or, at our option, replaced with a new product of equal or superior value if delivered to A.T.U.S. or an Authorized Service Center, pre-paid, together with the sales slip or other proof of purchase date. **Prior approval from A.T.U.S. is required for return.** This warranty excludes defects due to normal wear, abuse, shipping damage, or failure to use product in accordance with instructions. This warranty is void in the event of unauthorized repair or modification, or removal or defacing of the product labeling.

**For return approval and shipping information,** contact the Service Department, Audio-Technica U.S., Inc., 1221 Commerce Drive, Stow, Ohio 44224.

Except to the extent precluded by applicable state law, **A.T.U.S. will have no liability for any consequential, incidental, or special damages; any warranty of merchantability or fitness for particular purpose expires when this warranty expires.**

This warranty gives you specific legal rights, and you may have other rights which vary from state to state.

Outside the U.S.A., please contact your local dealer for warranty details.

## Polar Pattern

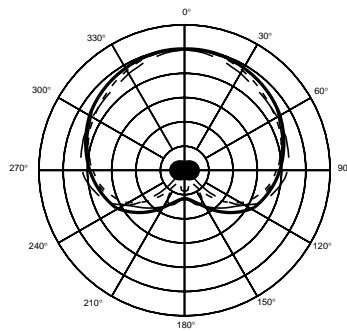

### LEGEND

200 Hz ———  
1 kHz ———  
5 kHz - - - - -  
8 kHz - - - - -

## Frequency Response

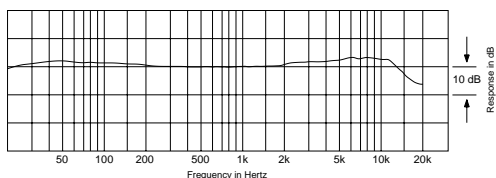

## Dimensions

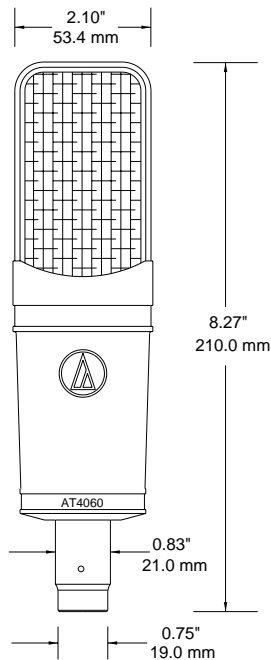

**audio-technica®**

Audio-Technica U.S., Inc., 1221 Commerce Drive, Stow, Ohio 44224

Audio-Technica Limited, Old Lane, Leeds LS11 8AG England

Form No. 0345-0825-00-B/W ©1998 Audio-Technica U.S., Inc. Printed in U.S.A.