

Bushnell®

NIGHT VISION INSTRUCTIONS

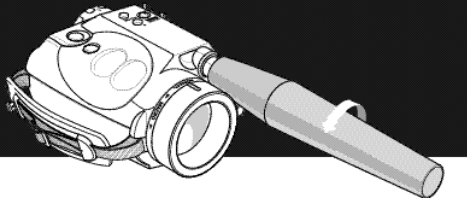

2.5x42

Audio Monocular • Monoculaire Audio
Audio Monocular • Audio-Spektiv

Model:
26-0300

Congratulations on the purchase of your Bushnell Night Vision Product. Bushnell Night Vision products are comprised of high quality image intensifier tubes and optics. Bushnell Night Vision products amplify existing light, allowing you to see in dark conditions too dark for the naked eye.

HOW NIGHT VISION WORKS

Bushnell Night Vision products collect and amplify existing light through the objective lens, which is then focused on the image intensifier. Inside the intensifier, a photocathode is "excited" by the light and converts the photon energy into electrons. These electrons accelerate across an electrostatic field inside the intensifier and strike a phosphor screen (like a green monochrome TV screen) which emits an image that you can see. It is the acceleration of electrons, which provides gain and enhances the image. This is a Generation I device.

Your Night Vision device offers a Directional Sound Amplification System (DSAS), providing you with the added benefit of a highly sophisticated sound amplification system. DSAS utilizes the latest developments in electronic sound amplification by combining our exclusive high sensitivity DIRECTIONAL microphone with a state of the art noise reduction system, providing unparalleled sound enhancement.

Your Night Vision device is ideal for a variety of professional and recreational uses including the following: Wild Life Observation, Astronomy, Boating / Marine Use, Police / Law Enforcement, Search and Rescue, Security, Property Management

GETTING STARTED

Installing Batteries

This device operates on two AA batteries. To install, unscrew the battery compartment cover located on the bottom of the unit. Insert the batteries into the battery compartment so that the (+) and negative (-) terminals of the batteries match the markings inside the compartment. Replace the battery cover carefully – do not over tighten.

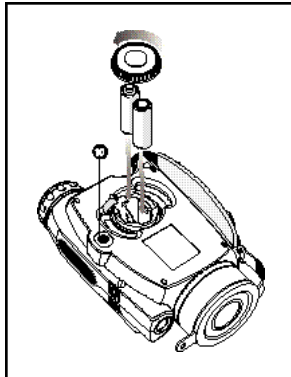

Use and Testing

This device operates on two AA batteries. Make sure they have been installed according to the instructions above.

Attach the receiving antenna of the DSAS directional microphone (1) and insert headphone plug into the audio output jack (2). If you wish to test your night vision device in a lighted area, be sure the objective lens cap is covering the objective lens (3) prior to pressing the "POWER" button. The objective lens cap has a pinhole opening to admit a small amount of light for testing purposes.

If testing or using the device in the dark, remove the objective lens cap and activate the device by pushing the "POWER" button (4).

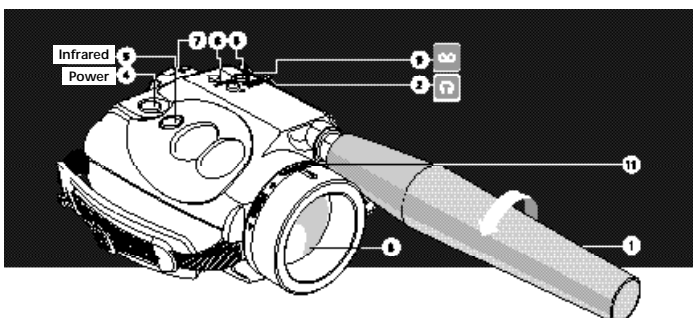

Set the preliminary focus adjustment by placing the adjusting mark (located on top of the objective focusing ring) opposite the letter "N" in the word "Normal" (11).

Place headphone in ears and activate the DSAS microphone by depressing the "ON" button (6).

If the subject is to be viewed in a completely dark area where no ambient light source (such as moonlight) is available, activate the Infrared Illuminator by pressing the Infrared Illuminator button (5) located next to the "POWER" button. Direct the device at an object at a distance approximately 100 yards and rotate the eyepiece (7) to give the best quality image. After the adjusting, do not rotate the eyepiece any longer irrespective of the distance and other conditions. Direct the device at the subject to be viewed and adjust the final focus by rotating the objective lens focusing ring until the image quality is optimal.

Adjust sound amplification volume to an optimal level by pressing the volume control buttons (8). If the sound is to be recorded, insert the tape recorder plug into the jack (9) and start recording.

The Green LED indicates that the light amplifier unit is on. The Red LED indicates that the Infrared Illuminator is on. The Yellow LED indicates that the DIRECTIONAL SOUND AMPLIFICATION SYSTEM is operating. Always remember to turn the unit off when done. Do not store this device while the indicators are lit. This device can be mounted on any tripod with a 1/4" tripod socket (10).

Caution: This device can be used in extreme cold weather. However, when the unit is brought back into a warm environment, you must wait approximately 5 hours before using the unit again. Damage may occur due to condensation that may have accumulated on the internal circuitry of the unit.

Spots In The Image

- You may see spots in the image. These vary from device to device and are cosmetic blemishes inside the device. These are normal for Night Vision devices and are NOT a defect.

TROUBLESHOOTING

Scope will not turn on.

Check that the batteries are installed properly. Replace the batteries with new ones. Check the battery contacts to ensure they are clean and free of corrosion. Check that the power is in the "ON" position.

Image is not focused.

Adjust the focus on the Eyepiece (7). Adjust the Objective Lens Focusing Ring. If still no improvement, clean the lenses; they may be foggy or dusty.

Visibility decreases or disappears.

Bright light sources such as headlights may cause visibility to degrade or disappear completely. Turn the Power OFF (4) and turn the scope away from the light source. The unit will restore itself in 1 or 2 minutes. Conditions such as fog or extremely dark environments will decrease visibility.

Scope flashes.

The scope may flash when used in a bright environment. It may also flash during the first few seconds of use in dark environments.

The sound amplification system is not amplifying properly.

Make sure the DIRECTIONAL antenna is tightly connected to the microphone. Check your headset connection; make sure your batteries are fresh.

CARE AND MAINTENANCE

Your Bushnell Night Vision device was designed to provide many years of reliable service. To ensure that you get the most enjoyment out of your Night Vision device, always obey the following warning and precautions:

- Do not point this device toward any light source greater than 1 lux such as car headlights, for an extended period of time. This device utilizes an internal flash protection system which minimizes potential damage, but long-term exposure to bright lights can damage the unit. Any such damage may void your warranty.
- This device was designed to be self-contained. Do not open the body of the device or otherwise attempt to service this device.
- Always store the device in a dry, well-ventilated room.
- Remove the batteries if the device is to be stored for longer than 2 months.
- Keep the device away from any heating and air conditioning vents or other heating devices, direct sunlight, and moisture.
- Avoid dropping or otherwise shocking the unit. Although designed for rugged outdoor use, this device incorporates a sophisticated optical system, which could be damaged in extreme cases of misuse.
- Clean the optical lenses with professional lens cleaning supplies.
- Clean the exterior of the device with a soft clean cloth.

SPECIFICATIONS

Magnification:	2.5 X
Objective Size:	42 mm
Vertical Resolution:	25 line/mm
Viewing Range (Ft.)*	4 -600 ft.
Range of Built-In Infrared Illuminator	90 yards
Field of View:	79 feet at 100 yards
Battery Type:	AA (2)
Operating Time:	Up to 20 hours
Temperature Range:	-22° to 104° F / -30° to 40° C
Eyeiece Adjustment:	+/- 5 diopter
Length:	6.7 inches / 170mm
Length with antenna:	14 inches / 365 mm
Width:	3.7 inches / 95mm
Height:	2.7 inches / 70mm
Weight:	17 oz. / 0.5 kg

Characteristics of the microphone:

Equivalent Noise Level:	20db
Sound Amplification:	0-66 db
Frequency Response:	500-10000 Hz
Sensitivity at frequency level of 1000 Hz	20+5mV/Pa

* Maximum distance at which a human figure can be recognized under ideal viewing conditions; defined as clear conditions (no fog, dust, etc.) under the light of 1/4 moon.

WARRANTY / REPAIR

One-Year LIMITED WARRANTY

Your Bushnell® Night Vision is warranted to be free of defects in materials and workmanship for one year after the date of purchase. In the event of a defect under this warranty, we will, at our option, repair or replace the product, provided that you return the product postage prepaid. This warranty does not cover damages caused by misuse or improper handling, installation or maintenance of the product.

Any return made under this warranty must be accompanied by the items listed below:

- 1) A check in the amount of \$15.00 to cover the cost of handling
- 2) Name and address for product return
- 3) An explanation of the defect
- 4) Product should be well packed in a sturdy outside shipping carton to prevent damage in transit and return postage prepaid to the address listed below:

IN U.S.A. Send To:

Bushnell Performance Optics
8500 Marshall Drive
Lenexa, Kansas 66214

In CANADA Send To:

Bushnell Performance Optics
25A East Pearce Street, Unit 1
Richmond Hill, Ontario L4B 2M9

For products purchased outside the United States and Canada please contact your local dealer for applicable warranty information. This warranty gives you specific legal rights. You may have other rights which vary from country to country.

©2001 Bushnell Corporation

Class 1 LED product per IEC 60825-1/nov 1993, appendix EN 60825-1A11/oct1996