

FLUKE®

Calibration

RUSKA 2470

Gas Lubricated Piston Pressure Gauge

Users Manual

LIMITED WARRANTY AND LIMITATION OF LIABILITY

Each Fluke product is warranted to be free from defects in material and workmanship under normal use and service. The warranty period is one year and begins on the date of shipment. Parts, product repairs, and services are warranted for 90 days. This warranty extends only to the original buyer or end-user customer of a Fluke authorized reseller, and does not apply to fuses, disposable batteries, or to any product which, in Fluke's opinion, has been misused, altered, neglected, contaminated, or damaged by accident or abnormal conditions of operation or handling. Fluke warrants that software will operate substantially in accordance with its functional specifications for 90 days and that it has been properly recorded on non-defective media. Fluke does not warrant that software will be error free or operate without interruption.

Fluke authorized resellers shall extend this warranty on new and unused products to end-user customers only but have no authority to extend a greater or different warranty on behalf of Fluke. Warranty support is available only if product is purchased through a Fluke authorized sales outlet or Buyer has paid the applicable international price. Fluke reserves the right to invoice Buyer for importation costs of repair/replacement parts when product purchased in one country is submitted for repair in another country.

Fluke's warranty obligation is limited, at Fluke's option, to refund of the purchase price, free of charge repair, or replacement of a defective product which is returned to a Fluke authorized service center within the warranty period.

To obtain warranty service, contact your nearest Fluke authorized service center to obtain return authorization information, then send the product to that service center, with a description of the difficulty, postage and insurance prepaid (FOB Destination). Fluke assumes no risk for damage in transit. Following warranty repair, the product will be returned to Buyer, transportation prepaid (FOB Destination). If Fluke determines that failure was caused by neglect, misuse, contamination, alteration, accident, or abnormal condition of operation or handling, including overvoltage failures caused by use outside the product's specified rating, or normal wear and tear of mechanical components, Fluke will provide an estimate of repair costs and obtain authorization before commencing the work. Following repair, the product will be returned to the Buyer transportation prepaid and the Buyer will be billed for the repair and return transportation charges (FOB Shipping Point).

THIS WARRANTY IS BUYER'S SOLE AND EXCLUSIVE REMEDY AND IS IN LIEU OF ALL OTHER WARRANTIES, EXPRESS OR IMPLIED, INCLUDING BUT NOT LIMITED TO ANY IMPLIED WARRANTY OF MERCHANTABILITY OR FITNESS FOR A PARTICULAR PURPOSE. FLUKE SHALL NOT BE LIABLE FOR ANY SPECIAL, INDIRECT, INCIDENTAL, OR CONSEQUENTIAL DAMAGES OR LOSSES, INCLUDING LOSS OF DATA, ARISING FROM ANY CAUSE OR THEORY.

Since some countries or states do not allow limitation of the term of an implied warranty, or exclusion or limitation of incidental or consequential damages, the limitations and exclusions of this warranty may not apply to every buyer. If any provision of this Warranty is held invalid or unenforceable by a court or other decision-maker of competent jurisdiction, such holding will not affect the validity or enforceability of any other provision.

Fluke Corporation
P.O. Box 9090
Everett, WA 98206-9090
U.S.A.

Fluke Europe B.V.
P.O. Box 1186
5602 BD Eindhoven
The Netherlands

11/99

To register your product online, visit register.fluke.com

Table of Contents

Chapter	Title	Page
1	Introduction	1-1
	How to Contact Fluke	1-1
	Safety Information	1-1
	Compressed Gas	1-1
	Lubricants and Seals	1-2
	Oxygen Compatibility	1-2
	Heavy Weights	1-2
	Personal Protective Equipment	1-2
	Symbols Used in this Manual	1-2
	Specifications	1-3
	Accuracy	1-4
2	General Piston Pressure Gauge Considerations	2-1
	Types of Piston Pressure Gauges	2-1
	Calculations	2-3
	Measurement of Pressure with the Piston Pressure Gauge	2-3
	Elastic Distortion of the Cylinder	2-4
	Gravity	2-4
	Buoyant Effect of the Air	2-4
	Temperature	2-5
	Reference Plane of Measurements	2-5
	Crossfloating	2-8
	Bibliography	2-8
3	Description	3-1
	General Information	3-1
	Description of the Mass Set	3-2
	Description of the Gauge Base	3-2
4	Installation	4-1
	Introduction	4-1
5	Operation	5-1

Precautions.....	5-1
General.....	5-2
Low Range Piston Assembly.....	5-2
Mid Range Piston Assembly.....	5-7
High Range Piston Assembly.....	5-10
Establishing Pressure.....	5-13
Gauge Pressures.....	5-13
Automating the Calculations and Data Storage.....	5-14
Leaks.....	5-15
Maintenance of the Gauge.....	5-15
6 Piston / Cylinder Cleaning Instructions	6-1
General Information and Preparation.....	6-1
Functional Testing of Piston/Cylinder Assemblies.....	6-2
Cleaning the Low Range Piston/Cylinder Assembly.....	6-2
Mid Range Piston/Cylinder.....	6-6
Cleaning the High Range Piston/Cylinder Assembly.....	6-8
Appendices	
A Explanation of "Pressure Calculation Worksheet".....	A-1
B Equation A-4 — Air Density.....	B-1
C Glossary.....	C-1

List of Tables

Table	Title	Page
1-1.	Symbols.....	1-2

List of Figures

Figure	Title	Page
2-1.	Simple Cylinder	2-1
2-2.	Re-Entrant Cylinder	2-1
2-3.	Controlled Clearance Cylinder.....	2-2
2-4.	Reference Plane Determination.....	2-6
2-5.	Head Correction Measurement.....	2-7
3-1.	Base with 2470 P/C Installed	3-2
3-2.	Base with 2468 P/C Installed	3-3
4-1.	FPI Mounting - RUSKA 2456 Piston Gauge Monitor	4-2
4-2.	Plumbing and Recommended Ancillary Equipment	4-3
5-1.	Section View, Low Range Piston/Cylinder.....	5-3
5-2.	Parts Required For Low Range Piston Operation	5-4
5-3.	Removing Low Range Piston and Cylinder from Container - Step 1	5-4
5-4.	Removing Low Range Piston and Cylinder from Container - Step 2	5-5
5-5.	Handling the Low Range Piston and Cylinder - Step 3	5-5
5-6.	Low Range Piston and Cylinder Showing O-Ring Groove	5-6
5-7.	Positioning the Upper Thrust Washer/Piston Retainer in the Cylinder Retaining Cap Recess.....	5-6
5-8.	Section View, Mid Range Piston/Cylinder	5-8
5-9.	Parts Required for Operation of the Mid Range P/C.....	5-9
5-10.	Mid Range Piston/Cylinder Assembly	5-9
5-11.	Retaining Nut and Bearing	5-10
5-12.	Section View, High Range Piston/Cylinder	5-11
5-13.	Parts Required for High Range Piston Operation	5-12
5-14.	Always Use Two Hands to Carry a Piston/Cylinder Assembly.....	5-12
5-15.	Order of Installation	5-13
5-16.	Float Position	5-14
6-1.	Materials for Cleaning Low Range Piston/Cylinder	6-3
6-3.	Preparing the Kim-Wipes - Step 1	6-4
6-4.	Preparing the Kim-Wipes - Step 2	6-5
6-5.	Preparing the Low Range Cleaning Tool - Step 1.....	6-5
6-6.	Preparing the Kim-Wipes - Step 2	6-6
6-7.	Materials for Cleaning the Mid Range Piston/Cylinder.....	6-6
6-8.	Preparing the Mid Range Cleaning Tool.....	6-7
6-9.	Materials for Cleaning the High Range Piston Cylinder.....	6-8
6-10.	Preparing the Kim Wipe for Cleaning the High Range Cylinder - Step 1	6-10

6-11. Preparing the Kim Wipe for Cleaning the High Range Cylinder - Step 2	6-11
6-12. Preparing the Kim Wipe for Cleaning the High Range Cylinder - Step 3	6-11
6-13. Cleaning the High Range Cylinder	6-11
6-14. Drying the High Range Cylinder	6-12

Chapter 1

Introduction

How to Contact Fluke

To order accessories, receive operating assistance, or get the location of the nearest Fluke distributor or Service Center, call:

- Technical Support USA: 1-800-99-FLUKE (1-800-993-5853)
- Calibration/Repair USA: 1-888-99-FLUKE (1-888-993-5853)
- Canada: 1-800-36-FLUKE (1-800-363-5853)
- Europe: +31-402-675-200
- China: +86-400-810-3435
- Japan: +81-3-3434-0181
- Singapore: +65-738-5655
- Anywhere in the world: +1-425-446-5500

Or, visit Fluke's website at www.fluke.com.

To register your product, visit <http://register.fluke.com>.

To view, print, or download the latest manual supplement, visit <http://us.fluke.com/usen/support/manuals>.

Safety Information

The following are general safety precautions that are not related to any specific procedures and do not appear elsewhere in this publication. These are recommended precautions that personnel must understand and apply during equipment operation and maintenance to ensure safety and health and protection of property.

Compressed Gas

Use of compressed gas can create an environment of propelled foreign matter. Pressure system safety precautions apply to all ranges of pressure. Care must be taken during testing to ensure that all pneumatic connections are properly and tightly made prior to applying pressure. Personnel must wear eye protection to prevent injury.

DO NOT use oxygen as a Pressure supply media. Use only dry, clean Nitrogen or equivalent.

DO NOT exceed the prescribed maximum inlet pressure for this device. See Chapter 1, Specifications, for more detail.

Lubricants and Seals

DO NOT use hydrocarbon lubricants in this device, use only approved lubricants.

Always use replacement parts specified by Fluke.

For more information regarding common replacement parts and recommended lubricants, see Appendix B.

Oxygen Compatibility

This Instrument has been designed with components that will not introduce hydrocarbons into the calibration process. The O-rings and lubricating grease supplied with the instrument must not be substituted with other laboratory supplies. For more information regarding common replacement parts and recommended lubricants, see Appendix B.

Cleaning the instrument for oxygen compatibility using HFCs and ultrasonic cleaning systems is permitted with the EXCEPTION OF THE PISTONS AND CYLINDERS. Ultrasonic cleaning may damage the crystalline structure of the tungsten carbide pistons and cylinders. The RUSKA procedures for piston/cylinder cleaning must be followed. See Chapter 5, Operation, for piston/cylinder cleaning instructions.

Heavy Weights

Lifting and movement of heavy weights can create an environment of strain and impact hazards. Care must be taken during testing to ensure that weight masses are lifted in a manner that avoids over-reaching or twisting, and that the masses are not dropped. Personnel must wear reinforced safety shoes to prevent injury.

Personal Protective Equipment

Wear eye protection and reinforced safety shoes approved for the materials and tools being used.

Warning





If the equipment is used in a manner not specified by the manufacturer, the protection provided by the equipment may be impaired.

Symbols Used in this Manual

In this manual, a **Warning** identifies conditions and actions that pose a hazard to the user. A **Caution** identifies conditions and actions that may damage the Gas Lubricated Piston Pressure Gauge or the equipment under test.

Symbols used on the Gas Lubricated Piston Pressure Gauge and in this manual are explained in Table 1-1.

Table 1-1. Symbols

Symbol	Description
	AC (Alternating Current)
	Earth Ground
	Important Information: refer to manual
	Shock Hazard
	Do not dispose of this product as unsorted municipal waste. Go to Fluke's website for recycling information.

Specifications

Low Range Piston

Pressure Range (Model 2465)	1.4 to 172 kPa (0.2 to 25 psi) psi gauge
Pressure Range (Model 2468)	1.4 to 345 kPa (0.2 to 50 psi) psi gauge
Pressure Uncertainty Rating	0.0010% (10 ppm) or 0.07 Pa (1.0E-05 psi), whichever is greater ^(1,2)
Uncertainty Threshold	7 kPa (1 psi)
Resolution	1 ppm or 1 mg, whichever is greater
Precision (Typical Type A Unc.)	3 ppm (3)
Long Term Stability	3 ppm per year
Piston/Cylinder Material	440C Stainless Steel/Tungsten Carbide
Thermal Coefficient	1.5E-05 per deg. C
Sink Rate at Maximum Pressure	typical <2 mm per minute, maximum 4 mm per minute

Mid Range Piston

Pressure Range (Model 2465)	12 to 700 kPa (1.7 to 100 psi) absolute or gauge
Pressure Range (Model 2468)	12 to 1380 kPa (1.7 to 200 psi) absolute or gauge
Pressure Uncertainty Rating	0.0010% (10 ppm) or 0.07 Pa (1.0E-05 psi), whichever is greater ^(1,2)
Uncertainty Threshold	35 kPa (5 psi)
Resolution	1 ppm or 1 mg, whichever is greater
Precision (Typical Type A Unc.):	3 ppm (3)
Long Term Stability	3 ppm per year
Piston/Cylinder Material	Tungsten Carbide/Tungsten Carbide
Thermal Coefficient	9.1E-06 per deg. C
Sink Rate at Maximum Pressure	typical <2 mm per minute, maximum 4 mm per minute

High Range Piston

Pressure Range	700 to 20680 kPa (100 to 3000) absolute or gauge
Pressure Uncertainty Rating	0.0030% (30 ppm) or 3.7 Pa (5.4E-04 psi), whichever is greater ^(1,2)
Uncertainty Threshold	248 kPa (36 psi)
Resolution	1 ppm or 1 mg, whichever is greater
Precision (Typical Type A Unc.)	3 ppm (3)
Long Term Stability	3 ppm per year
Piston/Cylinder Material	Tungsten Carbide/Tungsten Carbide
Thermal Coefficient	9.1E-06 per deg. C
Sink Rate at Maximum Pressure	typical <2 mm per minute, maximum 4 mm per minute

Mass Set

Approximate Total Mass	17.8 kg
Approximate Carrier Mass	0.58 kg
Smallest Increment	5.9 gram
Mass Material	300 Series, Non-magnetic, Austenitic, Stainless Steel ⁽³⁾
Adjustment Method	Completely machined with no fill cavities
Mass Uncertainty	0.0005% (5 ppm) or 5E-07 kg, whichever is greater
Optional Fine Increment Trim Set	ASTM Class 1, 20g to 1 mg

⁽¹⁾ Absolute mode uncertainty higher due to reference pressure sensor.

⁽²⁾ Approximate 95% level of confidence (Refer to Chapter 1, Accuracy, and to Calibration Report.)

⁽³⁾ Mass carrier composite construction 300 Series, Non-magnetic, Austenitic, Stainless Steel and other non-magnetic material.

Temperature Range

Operating	18 °C to 28 °C
Storage	-40 °C to 70 °C when thermometer and low range piston & Cylinder are stored separately from each other.

Humidity Range

Operating	20% to 75% noncondensing
Storage	0% to 90% noncondensing

Pressure Medium

Clean dry gas, Nitrogen or equivalent, regulated to a pressure Compatible with each particular Piston/cylinder assembly. Dew Point of less than or equal to -60 °F

Pressure

Maximum Working Pressure

2470 piston/Cylinder installed in 2470 Column adapter

With High Range Piston/Cylinder 3000 psig

2465 piston/Cylinder installed in 2465 Column adapter

With Mid Range Piston/Cylinder 100 psig (Do Not Exceed 6.31 Kg Mass Load)

With Low Range Piston/Cylinder 25 psig (Do Not Exceed 6.31 Kg Mass Load)

2468 piston/Cylinder installed in 2465 Column adapter

With Mid Range Piston/Cylinder 200 psig (Do Not Exceed 12.31 Kg Mass Load)

With Low Range Piston/Cylinder 50 psig (Do Not Exceed 12.31 Kg Mass Load)

Note

*The pressurized housing with the 2470 adapter has been tested to 4000 psig.
The pressurized housing with the 2465 adapter has been tested to 1000 psig.*

Accuracy

The gauge is capable of measuring pressures to the accuracy indicated below. See the calibration report for the actual accuracy of this gauge. The claim for accuracy is valid only when the gauge is operated according to the instructions provided with the equipment. In addition, the claim is valid when the value of gravity acting upon the weights is known to +/-0.001 cm sec².

Accuracy is defined as the departure of the measured pressure from the true pressure. The value is based on a simple error analysis of the calibration experiment and represents the sum of the systematic errors and two standard deviations of the random variability of the measurement process.

Gauge Pressure (0.0035% Class)

High Range Piston (0.013 sq in area)	0.0035 percent of reading or 0.002 psi, whichever is greater
Mid Range Piston (0.13 sq in area)	0.0035 percent of reading or 0.0002 psi, whichever is greater
Low Range Piston (0.52 sq in area)	0.0035 percent of reading or 0.00005 psi, whichever is greater

Chapter 2

General Piston Pressure Gauge Considerations

Types of Piston Pressure Gauges

The piston pressure gauge is sometimes regarded as an absolute instrument because of the principle by which it measures pressure. An absolute instrument is defined here as one capable of measuring a quantity in the fundamental units of mass, length, time, etc. It may be suggested that only certain types of piston pressure gauges qualify in this category.

Figures 2-1, 2-2, and 2-3 illustrate the three most common types of cylinder arrangements.

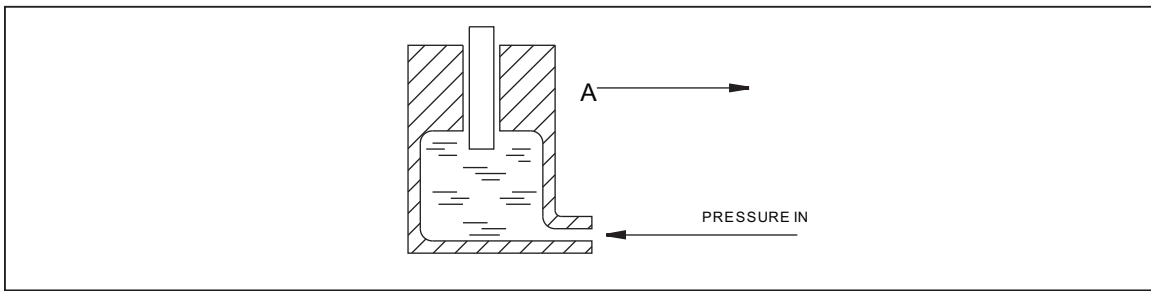

Figure 2-1. Simple Cylinder

glg01.eps

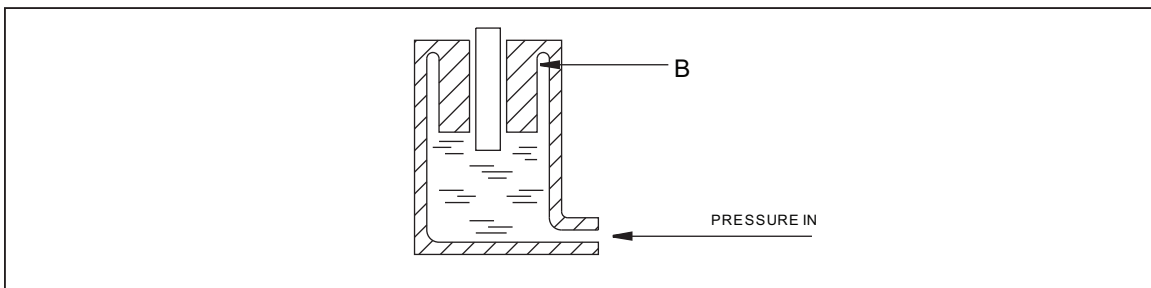
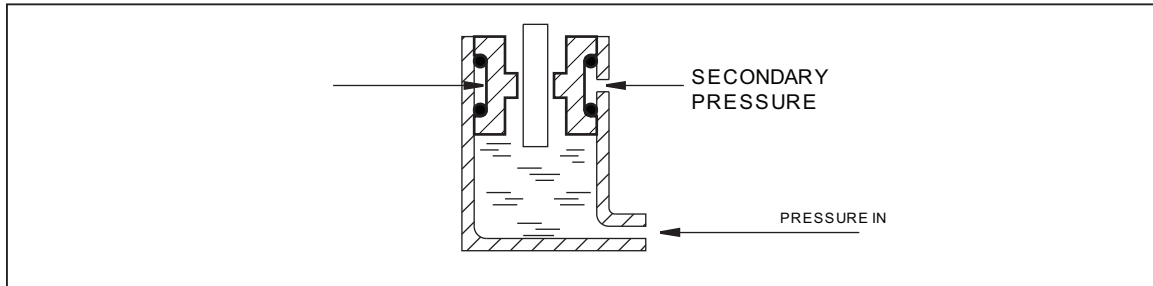

Figure 2-2. Re-Entrant Cylinder

glg44.eps



glg45.eps

Figure 2-3. Controlled Clearance Cylinder

When the simple cylinder of 2-1 is subjected to an increase in pressure, the fluid, exerting a relatively large total force normal to the surface of confinement, expands the cylinder and thus increases its area. A pressure-drop appears across the cylinder wall near point A, resulting in an elastic dilation of the cylinder bore.

It can be shown that the effective area of the piston and cylinder assembly is the mean of the individual areas of the piston and of the cylinder; therefore as the pressure is increased, the cylinder expands and the effective area becomes greater. The rate of increase is usually, but not always, a linear function of the applied pressure. The piston also suffers distortion from the end-loading effects and from the pressure of the fluid, but to a much lesser extent than the cylinder. It is evident then, that the simple cylinder of 2-1 would be inadequate for a primary piston pressure gauge unless some means of predicting the change in area were available.

The increase in the effective area of the simple cylinder is also accompanied by an increase in the leakage of the fluid past the piston. Indeed, the leakage becomes so great at some pressures that insufficient floating time can be maintained for a proper pressure measurement.

In Figure 2-2, the pressure fluid is allowed to surround the body of the cylinder. The pressure drop occurs across the cylinder wall near the top of the cylinder at point B, but in the opposite direction to that of the simple cylinder in Figure 2-1. In consequence, the elastic distortion is directed toward the piston, tending to decrease the area of the cylinder.

Again, the change in area with changing pressure places a limit on the usefulness of the cylinder in 2-2 for it as a primary instrument. But some benefit results from the use of this cylinder in the construction of a piston pressure gauge because higher pressures may be attained without a loss in float time. A small sacrifice is made in the float time at lower pressures because the total clearance between piston and cylinder must necessarily be greater at low pressure for the cylinder in 2-2 than for the cylinder in Figure 2-1.

In the controlled-clearance design of Figure 2-3, the cylinder is surrounded by a jacket to which a secondary fluid pressure system is connected. Adjustment of the secondary, or jacket, pressure permits the operator to change the clearance between the cylinder and piston at will. A series of observations involving piston sink rates at various jacket pressures leads to the empirical determination of the effective area of the assembly. Throughout the world, the controlled-clearance piston pressure gauge is an accepted standard of pressure.

Piston pressure gauges having very high resolutions may be made by using simple and reentrant cylinders. A determination of the distortion coefficients of such gauges may be made by direct comparison with a controlled-clearance gauge. Most piston pressure gauges have some elastic distortion, but some, used in the very low pressures, have only small coefficients and, in some instances, correction for distortion may be neglected.

Measurement of pressure with the piston pressure gauge is subject to uncertainties resulting from effects other than those of elastic distortion. But, it was appropriate that the subject of elastic distortion be discussed first, since this characteristic is largely responsible for the various designs that have been developed.

Measurement processes proposed for high accuracy are disturbed by limitations in the performance of the equipment, by small changes in the environment, and by operational procedures. The disturbances can be reduced to a degree by exercising control of the apparatus. Some of the disturbances are difficult to control; it is easier to observe their magnitudes and apply corrections for their effects.

The factors that affect a pressure measurement process when conducted with a piston pressure gauge are described below. It is important that the operator is acquainted with these factors and become accustomed to recognizing their presence. The success of the measurement will depend upon the degree to which control has been maintained, or to the completeness by which corrections were applied for these factors.

- Elastic distortions of the piston and cylinder.
- Effects of gravity on the masses.
- Temperature of the piston and cylinder.
- Buoyant effect of the atmosphere upon the masses.
- Hydraulic and gaseous pressure gradients within the apparatus.

Calculations

For a consolidation of these various corrections, see Appendix A of this manual. Appendix A contains a Pressure Calculation Worksheet (both SI and English units) with instructions. The Pressure Calculation Worksheet will step the user through the necessary corrections as applied to calibrations with a piston pressure gauge.

Measurement of Pressure with the Piston Pressure Gauge

Pressure results from the application of a force onto an area. Numerically, it is the quotient of the force divided by the area onto which it is applied:

$$P = \frac{F}{A}$$

Where:

- | | |
|----------|-------------------------|
| <i>P</i> | Represents the pressure |
| <i>F</i> | Represents the force |
| <i>A</i> | Represents the area |

Elastic Distortion of the Cylinder

As the pressure is increased within a piston pressure gauge, the resulting stress produces a temporary and reversible deformation of the cylinder. The net effect is a change in the effective area of the piston-cylinder combination. If the change in the area is a linear function of the applied pressure, the relationship may be described by the equation:

$$A_e = A_0(1 + b_1P + b_2P^2)$$

Where:

- P is the nominal pressure
- A_e is the effective area at a pressure, P
- A_0 is the area of the piston-cylinder assembly at a reference pressure level
- b_1 & b_2 are coefficients of elastic distortion which are determined experimentally

Gravity

Since pressure is defined as force per unit area, anything that changes the force applied to the piston of a piston pressure gauge also changes the pressure produced by that gauge. Therefore, the effects of gravity on the masses loaded on the piston must be considered. The gravity correction is usually very significant and must be used during calculations to achieve the advertised accuracy of the piston pressure gauge.

Confusion has resulted from the English System of units concerning the terms, mass and weight. The International System of units does not leave room for ambiguity and should be used whenever possible.

It is recognized that some facilities still operate under the English System of units. Therefore, this manual provides calibration data and calculation instructions in both the English and the International System of units.

Corrections for local gravity can vary by as much as 0.5% thus it is very important to have a reliable value for the local acceleration of gravity. A gravity survey with an uncertainty better than 0.00001 m/s² is recommended.

Buoyant Effect of the Air

According to Archimedes's principle, the weight of a body in a fluid is diminished by an amount equal to the weight of the fluid displaced. The weight of an object (in air) that has had its mass corrected for the effects of local gravity is actually less than that corrected value indicates. This reduction in weight is equal to the weight of the quantity of air displaced by the object, or the volume of an object multiplied by the density of the air. But the volume of an irregular shaped object is difficult to compute from direct measurement. Buoyancy corrections are usually made by using the density of the material from which the object is made. If the value of mass is reported in units of apparent mass vs. brass standards rather than of true mass, the density of the brass standards must be used. Apparent mass is described as the value the mass appears to have, as determined in air having a density of 0.0012 g/cm³, against brass standards of a density of 8.4 g/cm³, whose coefficient of cubical expansion is $5.4 \times 10^{-5}/^{\circ}\text{C}$, and whose value is based on true mass in value (see reference 4).

Although the trend is swinging toward the use of true mass in favor of apparent mass, there is a small advantage in the use of the latter. When making calculations for air buoyancy from values of apparent mass, it is unnecessary to know the density of the mass. If objects of different densities are included in the calculation, it is not necessary to distinguish the difference in the calculations. This advantage is obtained at a small sacrifice in accuracy and is probably not justified when considering the confusion that is likely to occur if it becomes necessary to alternate in the use of the two systems.

A satisfactory approximation of the force on a piston that is produced by the load is given by:

$$F = M_A \left(1 - \frac{P_{AIR}}{P_{BRASS}} \right) g$$

Where:

F	is the force on the piston
M_A	is the mass of the load, reported as "apparent mass vs. brass standards"
P_{AIR}	Is the density of the air
P_{BRASS}	Is the density of brass (8.4 g/cm ³)
g	is the acceleration due to local gravity

Temperature

Piston pressure gauges are temperature sensitive and must, therefore, be corrected to a common temperature datum.

Variations in the indicated pressure resulting from changes in temperature arise from the change in effective area of the piston due to expansion or contractions caused by temperature changes. The solution is a straightforward application of the thermal coefficients of the materials of the piston and cylinder. The area corresponding to the new temperature may be found by substituting the difference in working temperature from the reference temperature and the thermal coefficient of area expansion in the relation as follows:

$$A_{0(t)} = A_{0(r)} [1 + c (t - r)]$$

Where:

$A_{0(t)}$	is the effective area at temperature, t
$A_{0(r)}$	is the effective area at zero pressure and reference temperature, r
c	is the coefficient of thermal expansion

Reference Plane of Measurements

The measurement of pressure is linked to gravitational effects on the pressure medium. Whether in a system containing a gas or a liquid, gravitational forces produce vertical pressure gradients that are significant and must be evaluated. Fluid pressure gradients and buoyant forces on the piston of a pressure balance require the assignment of a definite position at which the relation $P = F / A$ exists.

It is common practice to associate this position directly with the piston as the datum to which all measurements made with the piston are referenced. It is called the reference plane of measurement, and its location is determined from the dimensions of the piston. If the submerged portion of the piston is of uniform cross section, the reference plane is found to lie conveniently at the lower extremity as shown in 2-4. If, however, the portion of the piston submerged is not uniform, the reference plane is chosen at a point where the piston, with its volume unchanged, would terminate if its diameter were uniform.

The reference plane of the standard is the effective bottom of the measurement piston. This location can be correlated to the index on the mass stack using the L1 dimension (found on Calibration Report for the Piston/Cylinder) and the D Dimension (found on Calibration Report for the Mass set).

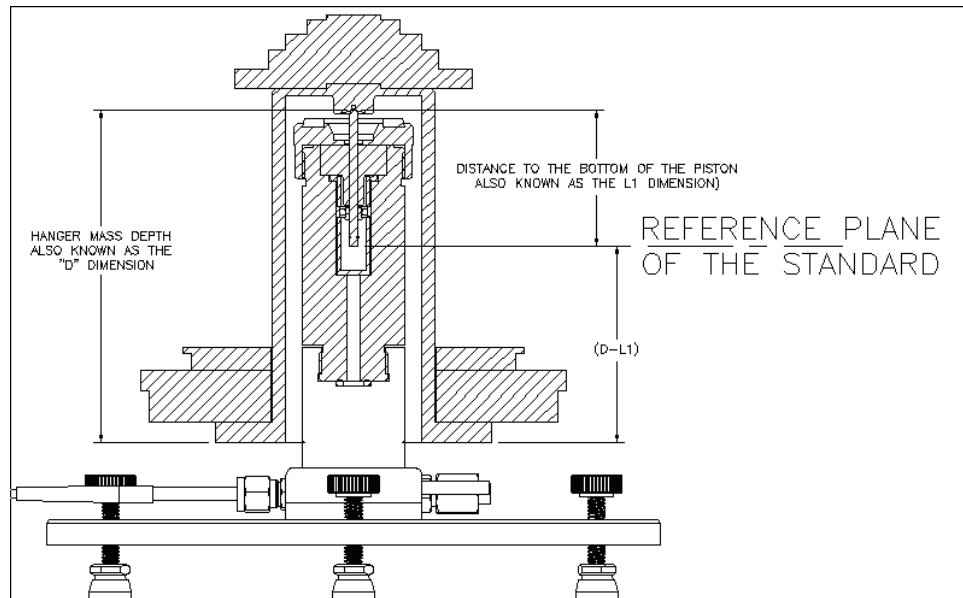
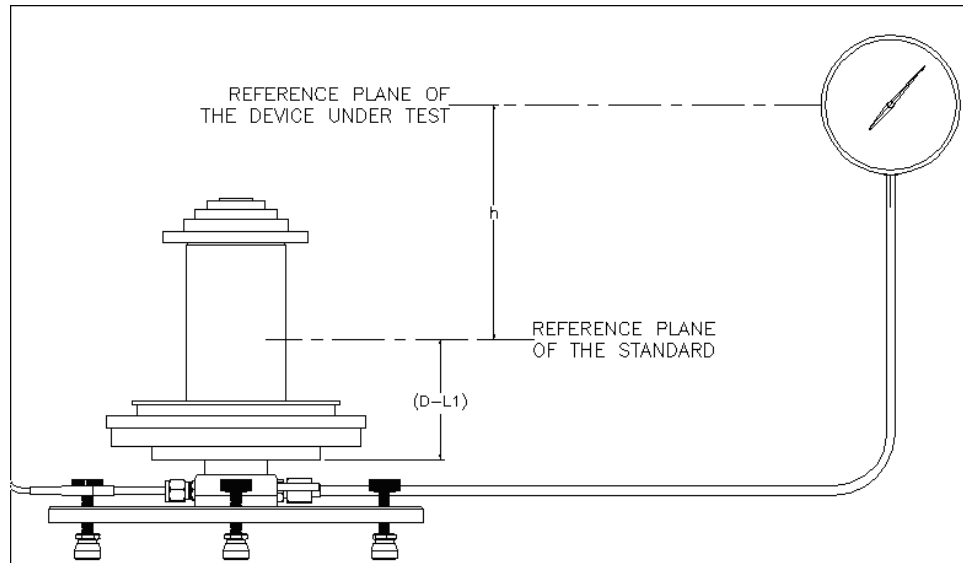

Figure 2-4. Reference Plane Determination

glg02.bmp

When a pressure for the piston pressure gauge is calculated, the value obtained is valid at the reference plane. The pressure at any other plane in the system may be obtained by multiplying the distance of the other plane from the reference plane by the pressure gradient and adding (or subtracting) this value to that observed at the piston reference plane.



glg03.bmp

Figure 2-5. Head Correction Measurement

$$P_H = (P_m - P_{AIR}) * h * g$$

Where:

- h is the vertical distance between the reference plane of the Standard and the reference plane of the DUT (Device Under Test)
- ρ_{air} is the density of the air
- ρ_m is the density of the test media
- g is the acceleration due to local gravity
- $L1$ is the vertical distance from the mass loading location to the effective bottom of the piston.
- D is the vertical distance from the mass loading location to the bottom of the Hanger Mass

Note

For instances where the reference plane of the DUT is LOWER than the reference plane of the standard, the h is a negative number and therefore P_H becomes a negative number.

In addition, gas lubricated piston pressure gauge calculations should account for the fact that the pressure gradient mentioned in the preceding paragraph changes as system pressure is changed. This is because the specific gravity of gas varies as a function of pressure, not remaining approximately constant, as does a hydraulic fluid.

For good work, a piston pressure gauge should be provided with an index mark for associating the reference of the piston with other planes of interest within a system. The design of this index will vary with the design and manufacture of the instrument, it may be in the form of an index rod with scribed lines on it, an index groove on the column of the instrument, or, other type of fixed indicator. Not only does the mark serve to establish fixed values of pressure differences through a system, it indicates a position of the piston with respect to the cylinder at which calibration and subsequent use should be conducted. If the piston is tapered, it is important to maintain a uniform float position for both calibration and use. This Position is referred to as the "Mid-Float" position as it represents the middle of the calibrated range of the Piston/Cylinder.

In normal operation, the system is pressurized until the piston is in a floating position slightly above the index mark. After a period of time, the piston and its load will sink to the line at which time the conditions within the system are stable. If there is a question as to the error that may be produced by accepting a float position that is too high or too low, the error will be equivalent to a fluid head of the same height as the error in the float position. This statement assumes that the piston is uniform in area over this length.

Crossfloating

It was mentioned earlier that some piston pressure gauges must be calibrated against a standard gauge. In the jargon of the laboratory, this process is called crossfloating. When crossfloating one gauge against another, the two are connected together and brought to a common balance at various pressures. The balancing operation is identical with that employed on an equal-arm balance where the mass of one object is compared to another. In each instance the operator must decide when the balance is complete. In a crossfloat, the two gauges are considered to be in balance when the sink rate of each is normal for that particular pressure. At this condition there is no pressure drop in the connecting line, and consequently no movement of the pressure medium. The condition can be difficult to recognize, particularly if there is no means of amplification in the method of observing. The precision of the comparison will depend directly upon the ability of the operator to judge the degree to which the balance is complete. This procedure is repeated for several pressures, and the values of areas obtained are plotted against the nominal pressure for each point. A least-squares line is fitted to the plots as the best estimate value of the area at any pressure.

There are two accepted methods for determining the balance of the two pressures. First, the sink rates can be observed and graphed using high sensitivity sensors. Second, a sensitive null-pressure transducer can be interposed which will display small pressure differences directly.

When using a suitable amplifying device, the scatter in the plotted areas from a good quality piston gauge should not exceed a few parts per million.

Bibliography

1. Bridgman, P. W., *The Physics of High Pressure*, G. Bell & Sons, London, 1952.
2. Cross, J. L., "Reduction of Data for Piston Gauge Pressure Measurements". NBS Monograph 65 (1963).
3. Dadson, R. S., "The Accurate Measurement of High Pressures and the Precise Calibration of Pressure Balances", *Proc. Conf. Thermodynamic and Transport Properties of Fluids*, London, pp. 32-42, 1957, Institute of Mechanical Engineers.
4. "Design and Test of Standards of Mass", NBS Circular No. 3 (Dec., 1918), Included in NBS Handbook 77, Volume III.
5. Johnson, D. P., J. L. Cross, J. D. Hill, and H. A. Bowman, "Elastic distortion Error in the Dead Weight Piston Gauge", *Ind. Engineering Chem.*, 40, 2046 (Dec., 1957).

6. Johnson, D. P., and D. H. Newhall, "The Piston Gauge is a Precise Measuring Instrument", *Trans. of ASME*, April, 1953.
7. Newhall, D. H. and L. H. Abbot, "Controlled-Clearance Piston Gauge", *Measurements and Data*, Jan.-Feb. 1970.
8. "Pressure Measurement", *Measurements & Data Home Study Course*, No. 17, *Measurements and Data*. September-October, 1969.
9. Tate, D. R., *Gravity Measurements and the Standards Laboratory*, National Bureau of Standards Technical Note No. 491 (1969).
10. Heydemann and Welch, Chapter 4, Part 3, "Pure and Applied Chemistry", Butterworths.
11. Kirk K. Mosher, Ruska Instrument Corporation, "The Traceability Chain of the Piston Pressure Gauge to NIST", presented at the Canadian National Conference of Standards Laboratories, 1991.
12. Ken Kolb, Ruska Instrument Corporation, "Reduced Uncertainty and Improved Reliability for the Pneumatic Piston Pressure Gauge through Statistical Process Control" published in the "Proceedings" for the Annual Measurement Science Conference, 1991.

Chapter 3

Description

General Information

The RUSKA Gas Lubricated Piston Pressure Gauge, model 2470 is a pneumatic pressure standard designed for the accurate generation and measurement of gas pressures to 3000 psig. This measurement is accomplished in the basic manner of using the fundamental pressure equation $\text{PRESSURE} = \text{FORCE}/\text{AREA}$ (see Chapter 2, General Piston Pressure Gauge Considerations, for more information). The gauge is used as the precision measuring device in the RUSKA Gas Lubricated Piston Pressure Gauge System.

It may be seen from the above general equation that when a known force produced by a known mass is applied to a piston of a known area, a pressure will be produced that may be calculated (see Appendix A for detailed information). The RUSKA gauge is arranged for the application of carefully determined masses on a piston of known area.

A key feature of the gauge is its ability to accurately reproduce its performance at the lower pressures. The low viscosity of the gas provides excellent lubrication for the close-fitting piston/cylinder assembly. Relative motion between the piston and cylinder is necessary and is obtained by hand rotation of the masses and table which will then distribute the gas molecules throughout the annulus of the assembly. It is the relative absence of friction between piston and cylinder walls that characterizes the performance for which the gauge is so highly respected.

The nominal range of pressure (interval) over which the gauge is capable of operating is the span from 1.4 kPa (0.2 psig) to 20.6 MPa (3000 psig). This interval is covered by three interchangeable piston/cylinder assemblies having sufficient overlap for establishing continuity of measurement and for making detailed investigations of subintervals within the total range (span).

Some of the most important industrial uses of the gas lubricated piston pressure gauge is that of a standard for calibrating transducers, Bourdon-tube type gauges, manometers, and other dead weight gauges. Frequently, the gauge is used in combination with the pressure null transducer (RUSKA model 2413 or similar) for cross float calibrations between gaseous and hydraulic media.

Description of the Mass Set

All masses of the Mass Set as supplied with this gauge are made of non-magnetic, austenitic (series 300) stainless steel (1). They are machined from rolled stock or forgings, and the removal of any metal is performed in such a way as to maintain balance about the centerline. Final mass adjustment is usually accomplished by drilling a symmetrical pattern of holes concentric with the axis.

Description of the Gauge Base

The Gauge base incorporates simple, sturdy construction and is equipped with three adjustable feet.

1. Mass carrier composite construction 300 Series, Non-magnetic, Austenitic, Stainless Steel and other non-magnetic material.

The base has an integral thermowell to accommodate a glass thermometer, or precision temperature probe (Platinum Resistance Thermometer). The thermowell allows for accurate temperature measurement of the test media and Piston/Cylinder.

The base features pre-drilled holes to facilitate installation of inductive Float Position sensors (RUSKA Model 2456 Piston Gauge Monitor or equal).

The most exciting feature of the base is the “Split-Column” design. This design allows for piston cylinders of different configuration to be mounted on the same base and operated with the same mass set. The Split Column allows for the operation of the base with the standard 2470 Piston/Cylinder as shown in Figure 3-1 and with the 2468 Low-Range or the 2468 Mid-Range Piston/Cylinders as shown in Figure 3-2.

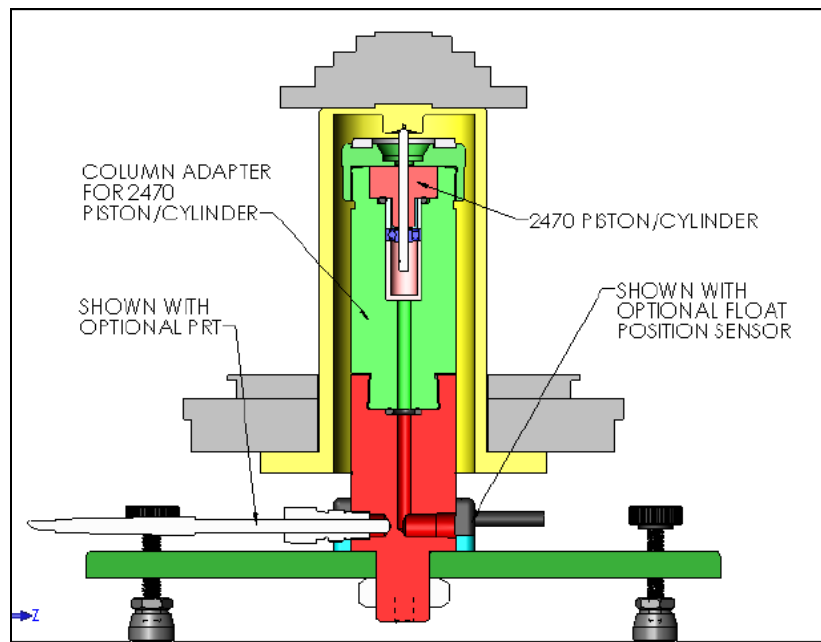
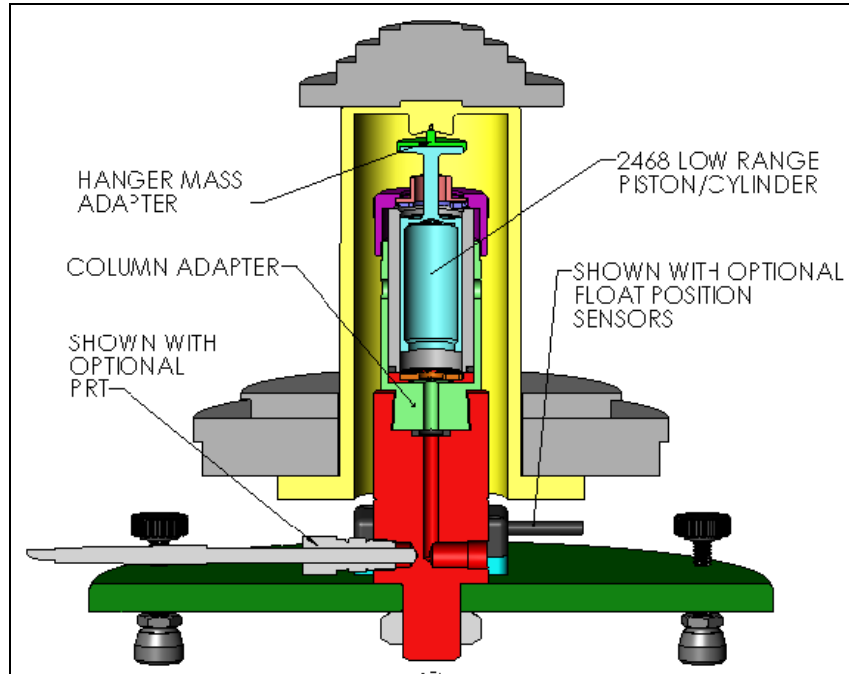

Figure 3-1. Base with 2470 P/C Installed

gmq04.bmp



gmq05.bmp

Figure 3-2. Base with 2468 P/C Installed

Chapter 4

Installation

Introduction

The gauge should be installed in a room where the temperature is maintained between 18 °C to 28 °C. The actual temperature is not as important as the stability in temperature. There should not be excessive personnel traffic and air drafts. Airborne dust is undesirable, but clean-room standards are not required.

1. Remove the gauge from its shipping box and locate it on a clean, level, sturdy work surface. The surface should be able to support fifty pounds of weight without deflecting and be secure enough to be free from vibration.
2. Level the base by turning the three leveling screws until the bubble in the level vial is centered.
3. Connect the pressure housing fitting to the pressurizing source and to the test instrument with 1/4" O.D. stainless steel tubing which has a working pressure rating of 3,000 psi or more. The tube requires a 37 degree flare for AN4 tube nut. Final tightening of the tube nuts should be delayed until after the base has been leveled. The pressure housing may be reoriented on the base if it is desired, but when the thermometer is on the left side, the numerals are inverted.
4. The pressurizing source should appropriate regulator, valves, and system volume adjuster to control the supply gas pressure from 0 to 3000 psi. Refer to Figure 4-2 for the recommended plumbing schematic. The RUSKA Series 3990 Manual Pressure Control Packs is recommended for this application.
5. Loosen the tube nut to the pressure housing fitting and level the instrument base.
6. Lock the level screws with the nuts located beneath the base plate. A 7/16" open-end wrench is required.
7. Tighten the pressure fitting nut being careful that the residual stress in the connecting tube is small and that the instrument base is not forced out of level.

If the RUSKA 2456 Piston Gauge Monitor is being used with the instrument. Attach the RUSKA 2456 to the instrument base as follows:

1. Install the PRT holder fitting in the thermowell on the base.
2. Install the PRT (Platinum Resistance Thermometer) in the fitting using a dab of Heat sink compound on the tip of the PRT. (Heat sink compound is provided with the kit which adapts the RUSKA 2470 base to the RUSKA 2456). The heat sink compound will reduce the response time of the PRT.
3. Mount the (2) FPI spacer blocks (P/N 2455-2470-001) to the top of the base plate as shown in Figure 4-1 using the screw provided.

4. Mount the FPIs (Float Position Sensors) to the blocks, orient the FPI sensors such that their cables are trail away from the base in the same direction as the PRT cable.
5. Route the cables from the FPIs and the PRT such that they do not interfere with other activities on the calibration bench.
6. Connect the PRT and FPIs to the RUSKA 2456 per instructions found in the RUSKA 2456 Manual.
7. Readjust the leveling screws if necessary until gauge is level in 2 axes by using the bubble gauge.
8. Install the desired piston and cylinder assembly into the housing. See Chapter 5, Operation, for operation of the gauge.
9. If the optional glass thermometer is being used, insert it into the 1/4 NPT hole in the right hand side of the Base Assembly. The graduated end of the thermometer will protrude through the hole in the right hand side of the base casting. Here too, a small amount of heat sink compound applied to the bulb of the thermometer will shorten the response time of the thermometer.

⚠ Caution

Always remove the thermometer before shipping the gauge base.

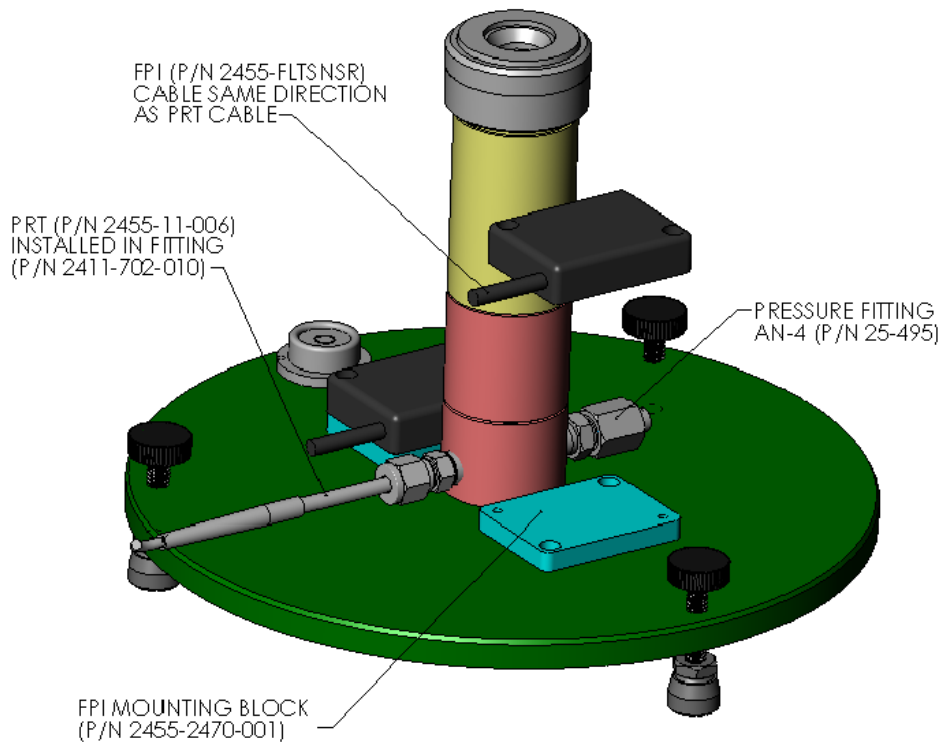

Figure 4-1. FPI Mounting - RUSKA 2456 Piston Gauge Monitor

gmq06.bmp

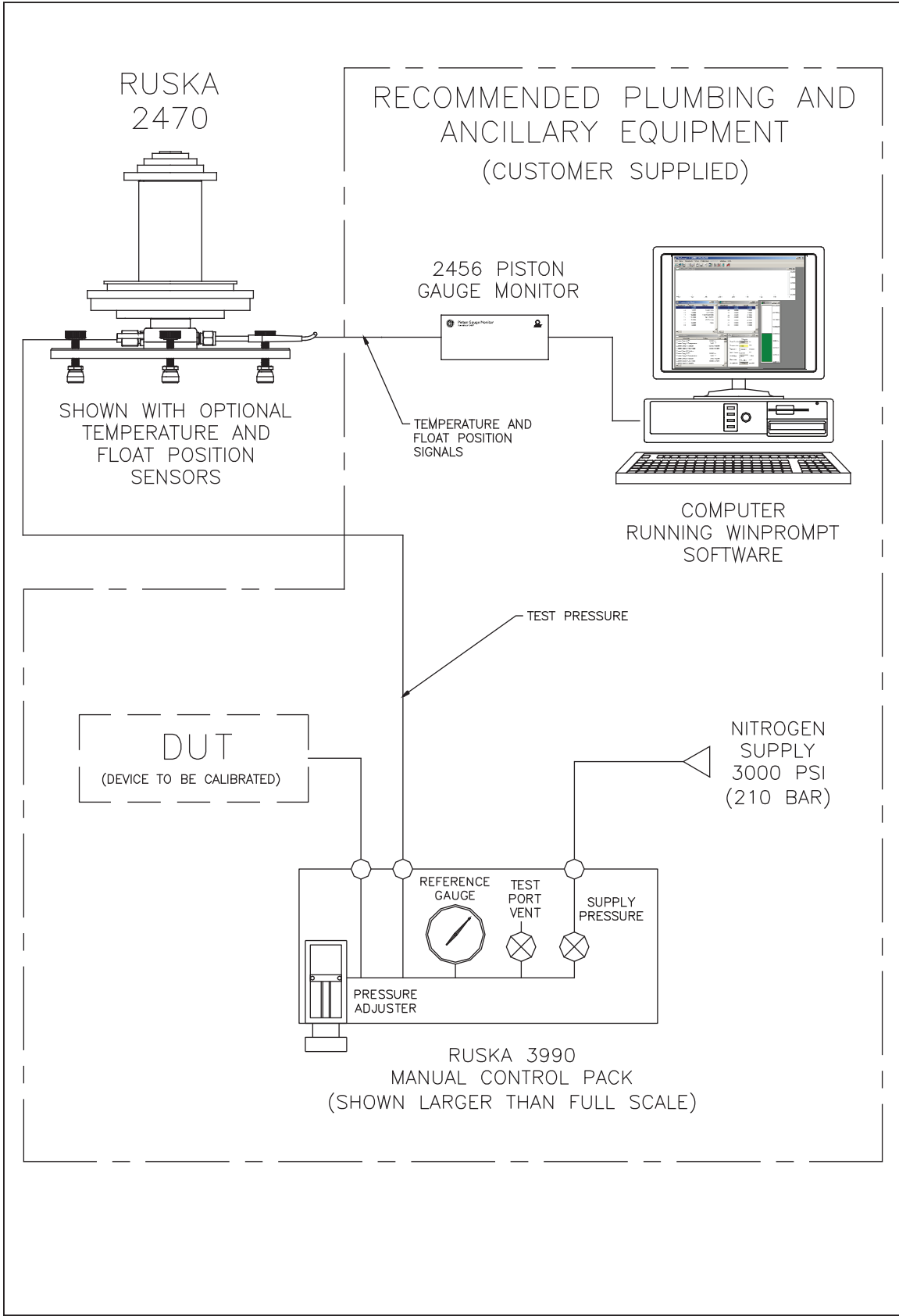

Figure 4-2. Plumbing and Recommended Ancillary Equipment

gmq07.eps

Chapter 5

Operation

Precautions

1. Do not over pressure the piston
2. Do not increase or decrease the pressure in the gauge rapidly. Always use a metering valve for flow control. If possible, hold a hand lightly on the weights to protect the piston from injury. The maximum rate is 0.7 MPa (100 psi) per minute.
3. Before operation, be sure the retaining ring of the high pressure piston is securely in place.
4. Do not operate the gauge with a dirty or sticky piston.
5. Do not rotate the pistons against the upper or lower stop longer than necessary because the bearings, of necessity, are not lubricated.
6. Because of extremely small tolerances between mating parts, every effort should be made to insure careful handling of gauge parts. All parts, especially those concerned with the piston and cylinder, should be kept scrupulously clean. Acid from finger prints can etch a piston or cylinder. Handle piston and cylinder using cotton gloves on the hands to prevent acid etching of piston and cylinder walls.
7. Pistons and cylinders are matched assemblies. Each piston will operate properly only in its particular cylinder.
8. Any sound which indicates metal-to-metal contact between the piston and cylinder is a signal for the operator to stop the gauge immediately. Failure to do so may cause damage to the piston and/or cylinder.
9. Always give the serial number of the instrument when ordering replacement parts.
10. The circular weight-loading table of the Low Range Piston must never be permitted to enter the bore of the mating cylinder. The assembly must always be handled as described in Chapter 6, Piston/Cylinder Cleaning Instructions. Precautions must always be taken to prevent uninformed and inexperienced persons from carelessly picking up this assembly for inspection.
11. The Low Range Piston/Cylinder (2460-5) must always be assembled in the cylinder housing with the O-ring relief on the cylinder in the downward position. See Figure 5-1.

General

The cross-section drawings of the Gauge found in Figures 5-1, 5-8 and 5-12 will aid in identifying and assembling the appropriate parts, and in determining the order of installation.

If the High Range Piston Assembly is to be used, the 2470 Column adapter is required.

1. If not in place, remove the 2465/2468 P/C from the column, store safely in its P/C container per instructions below.
2. Install the 2470 style column top (P/N 2470-1-143). Tighten the column top firmly by hand while holding the bottom section of the column with the opposite hand. The column adapter should make a pressure tight seal against the Column O-ring (P/N 54-703-109).
3. The O-Ring should be lightly lubricated with Dupont Krytox Grease (45-351) before installation. All excess lubricant should be wiped off, leaving only a slight film

Conversely the Low or the Mid-range P/C is to be used:

1. Remove the 2470 P/C from the column and store it in the P/C shipping container.
2. Unscrew the 2470 style column top and install the 2465 style Pressure housing adapter (P/N 2465-4-1).
3. Tighten the column top firmly by hand while holding the bottom section of the column with the opposite hand. The column adapter should make a pressure tight seal against the Column O-ring (P/N 54-703-109).
4. The O-Ring should be lightly lubricated with Dupont Krytox Grease (45-351) before installation. All excess lubricant should be wiped off, leaving only a slight film.

Low Range Piston Assembly

Refer to Figures 5-1, and 5-2. If the Low Range Piston Assembly is to be used:

1. Drop the filter (24-580) and filter retainer (2460-4-27) into the base.
2. Drop the lower thrust bearing (2460-4-25) into the recess at the top of the filter retainer. (See Figure 5-2.) The O-ring (54-703-119) rests on top of the filter retainer and seals against the bottom of the cylinder.
3. The O-Ring should be lightly lubricated with Dupont Krytox Grease (45-351) before installation. All excess lubricant should be wiped off, leaving only a slight film

The lower thrust bearing must be in the gauge when the Low Range Piston is being used.

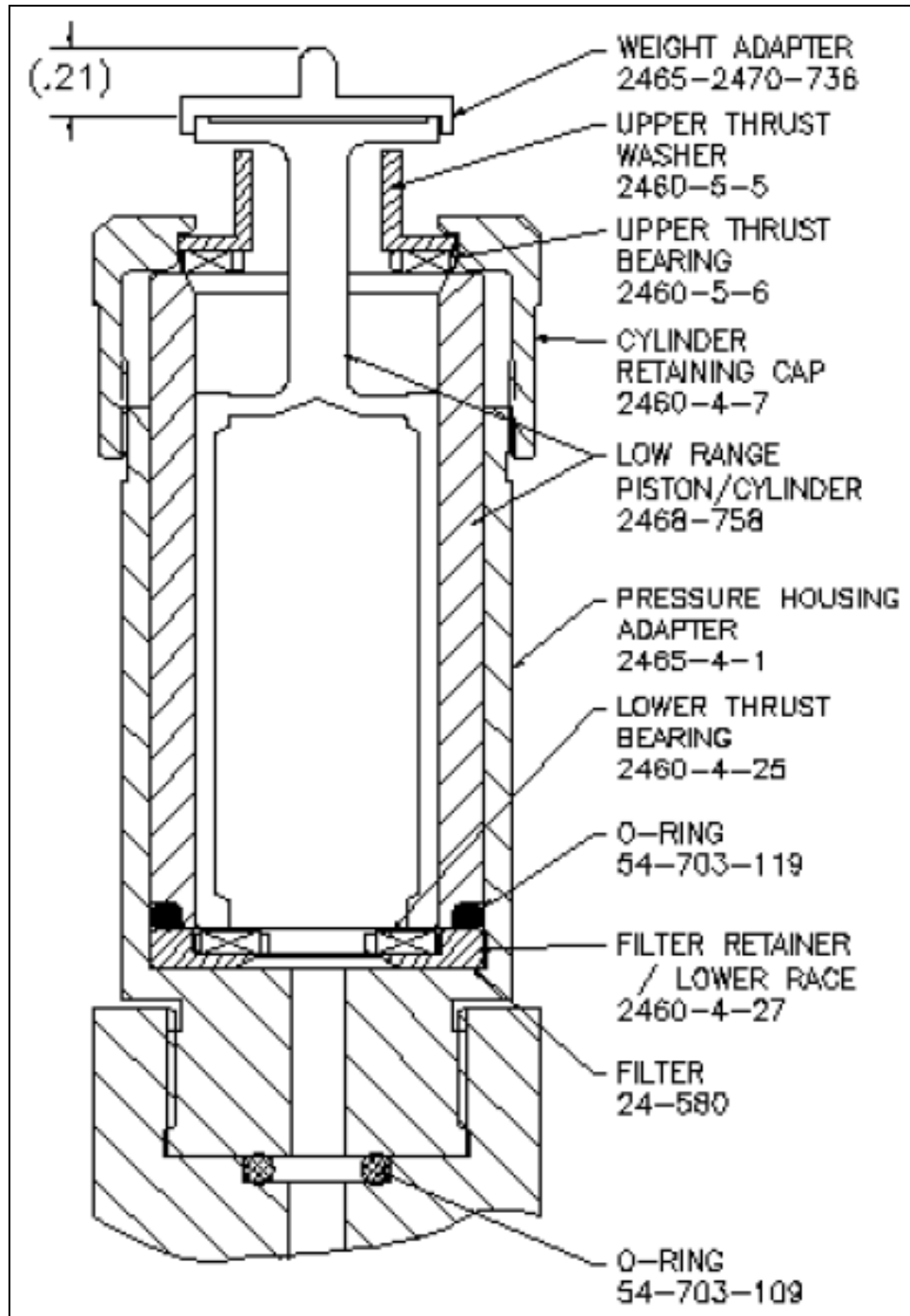
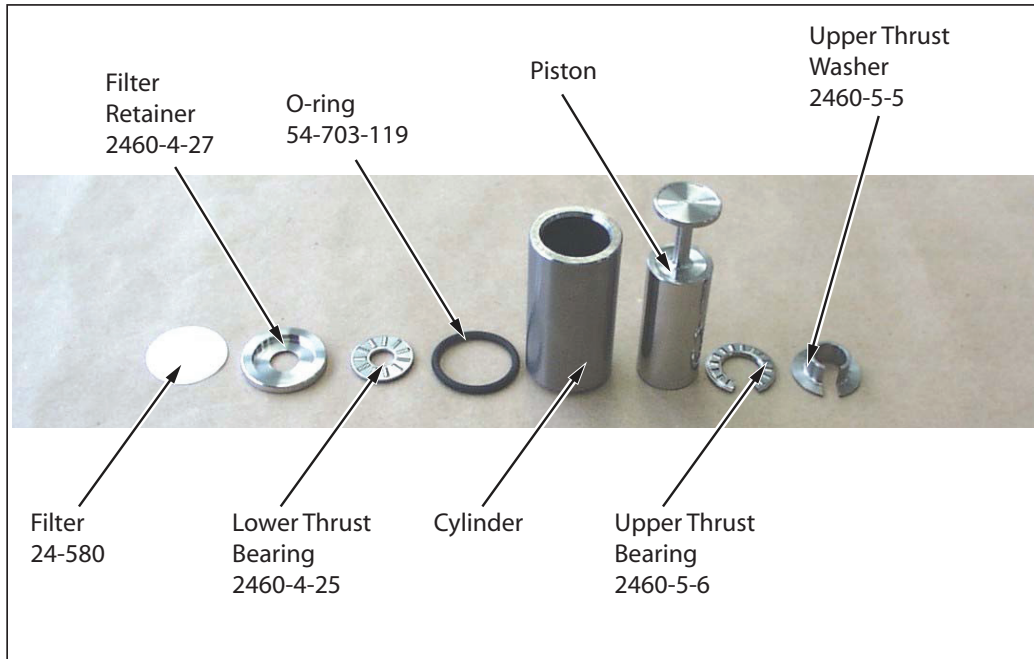

Figure 5-1. Section View, Low Range Piston/Cylinder

gmq09.bmp



gmq10.eps

Figure 5-2. Parts Required For Low Range Piston Operation

⚠ Caution

When handling the Low Range Piston and Cylinder Assembly, do not allow the weight loading table to enter the cylinder bore. When handling the assembly, maintain a firm grasp on the weight loading table until the assembly is in the housing. See Figures 5-3, 5-4, and 5-5 for proper handling of the Low Range Piston and Cylinder.



gmq11.bmp

Figure 5-3. Removing Low Range Piston and Cylinder from Container - Step 1



Figure 5-4. Removing Low Range Piston and Cylinder from Container - Step 2

gmq12.bmp



Figure 5-5. Handling the Low Range Piston and Cylinder - Step 3

gmq13.bmp

4. The Low Range Cylinder (2460-5-1) and Low Range Piston Assembly (2460-55) should then be placed in the gauge after being cleaned according to the instructions in Chapter 6, Piston/Cylinder Cleaning Instructions.

⚠ Caution

The O-ring groove on the cylinder should be in the downward position when the cylinder is placed in the gauge. See Figures 5-1 and 5-6.



gmq14.bmp

Figure 5-6. Low Range Piston and Cylinder Showing O-Ring Groove

5. When screwing the Retaining Cap (2460-4-7) onto the cylinder, a slight upward force may be necessary on the piston to properly seat the Piston Retainer (2460-5-5) into the inner recess of the Retaining Cap. See Figure 5-7.



gmq15.bmp

Figure 5-7. Positioning the Upper Thrust Washer/Piston Retainer in the Cylinder Retaining Cap Recess

6. Tighten this cap securely by hand while holding the column with the opposite hand.
7. Before proceeding, check the level vial to verify that the base is level, adjust the level of the base if necessary.

8. Install the weight adapter (P/N 2465-2470-736) to the top of the low range piston cylinder. Take care to account for the adapter in the pressure calculations.
 - Add the Mass of the adapter to the tare for the Piston
 - Add the height of the adapter to the L1 dimension for the Cylinder (approximately .21 inches)

The gauge is now ready for operation.

Mid Range Piston Assembly

Refer to Figures 5-8, 5-9, 5-10, and 5-11.

If the Mid Range Piston Assembly is to be used:

1. The Lower Thrust Bearing (2460-4-25) mentioned in the preceding section, Chapter 5, Low Range Piston Assembly, must be left in the gauge with the Filter, Filter Retainer, and O-Ring as described in that section.
2. Next, insert the Lower Cylinder Spacer, O-Ring, and the piston and cylinder after they have been cleaned according to the instructions in Chapter 6, Piston /Cylinder Cleaning Instructions. The O-Rings should be lubricated with Dupont Krytox 240 Grease (45-351) before installation. All excess lubricant should be wiped off, leaving only a slight film.
3. Place the Cylinder Retainer (2460-70-2) over the cylinder.
4. Place the Cylinder Retaining Cap (2460-4-7) onto the housing.
5. Tighten this cap securely by hand while holding the column with the opposite hand.
6. Before proceeding, check the level vial to verify that the base is level, adjust the level of the base if necessary.
7. Install the weight adapter (P/N 2465-2470-736) to the top of the low range piston cylinder. Take care to account for the adapter in the pressure calculations.
 - Add the Mass of the adapter to the tare for the Piston
 - Add the height of the adapter to the L1 dimension for the Cylinder (approximately .21 inches)

The gauge is now ready for operation.

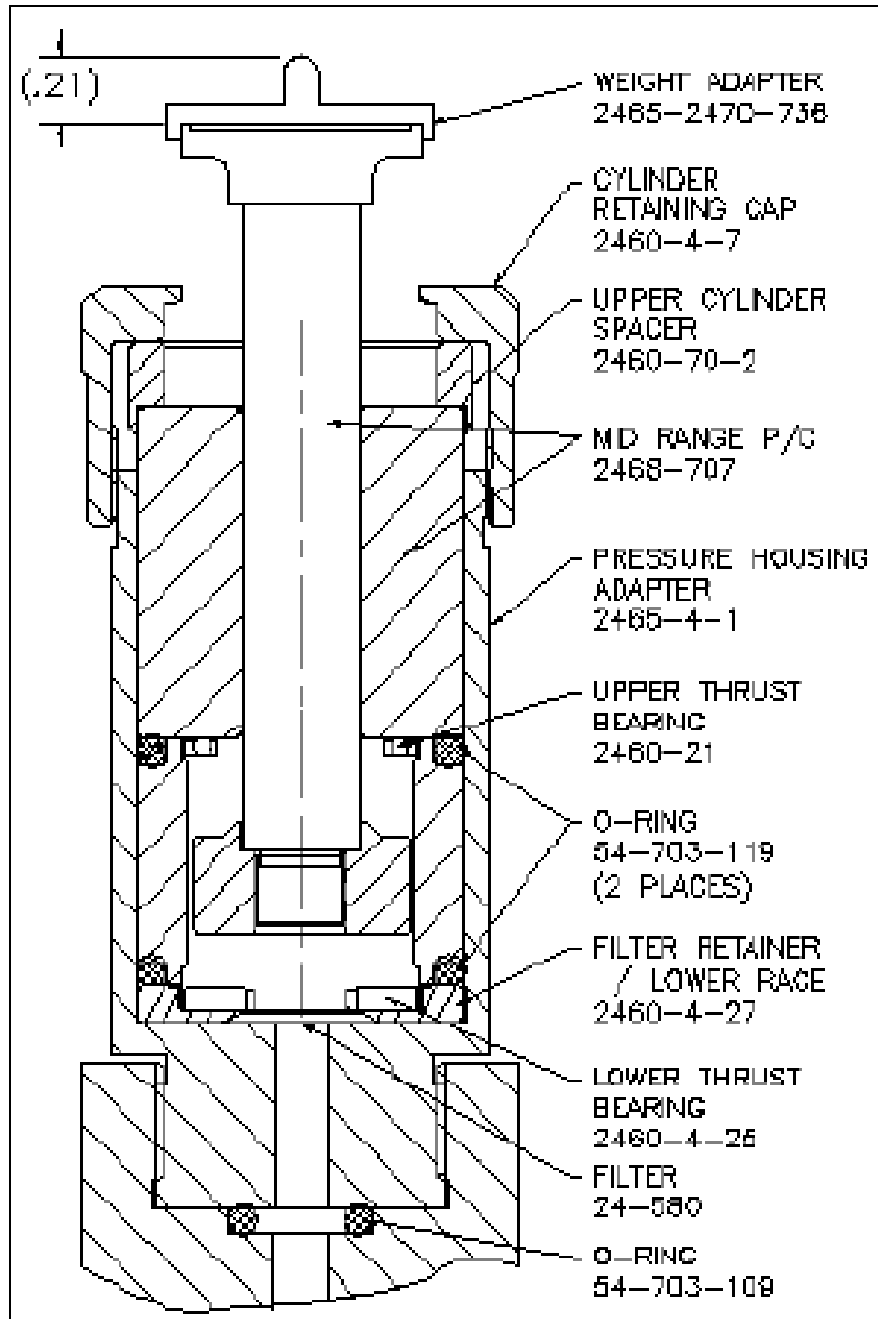
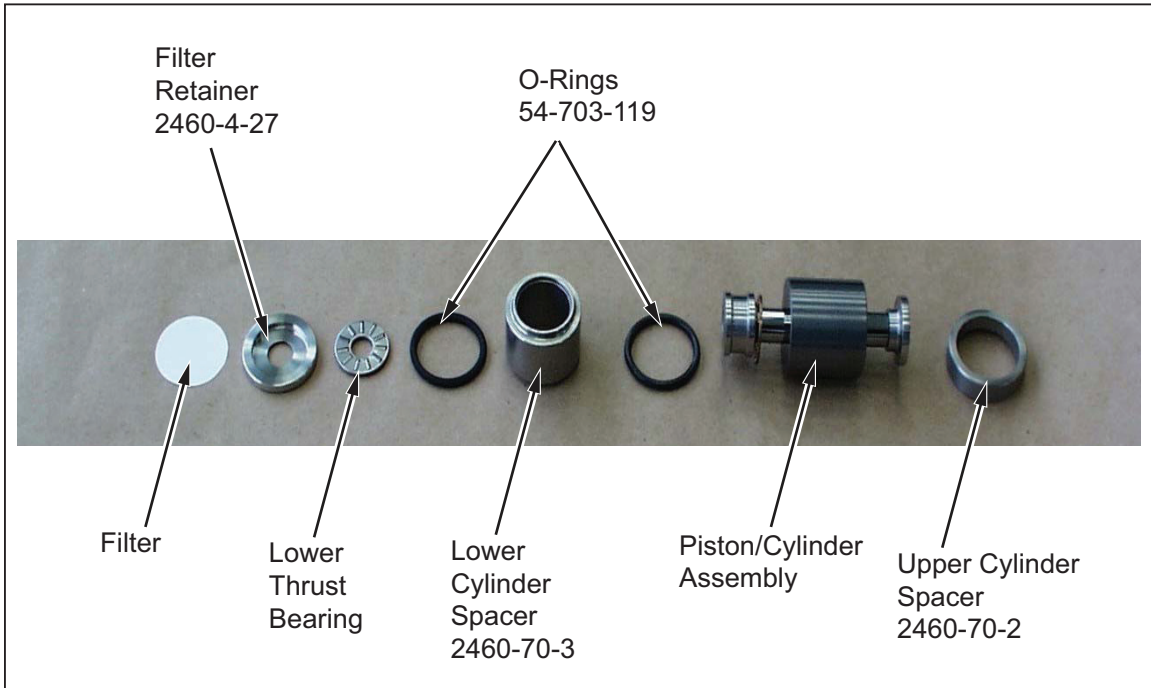

Figure 5-8. Section View, Mid Range Piston/Cylinder

gmq16.bmp



gmq17.eps

Figure 5-9. Parts Required for Operation of the Mid Range P/C



gmq18.bmp

Figure 5-10. Mid Range Piston/Cylinder Assembly

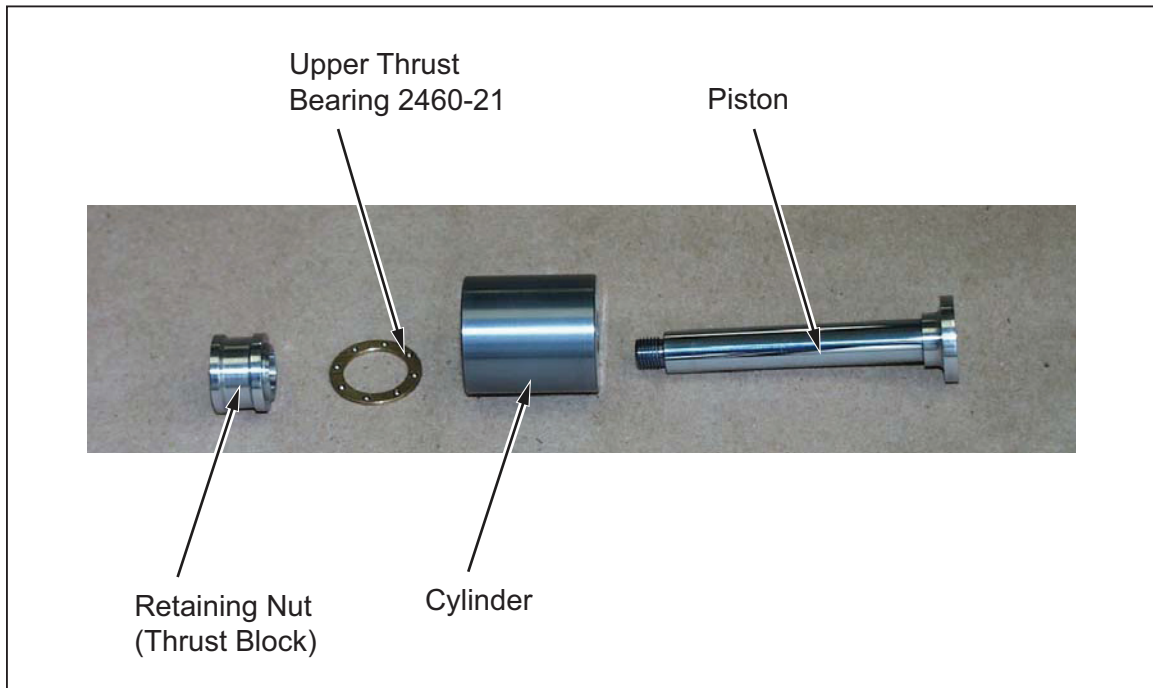

Figure 5-11. Retaining Nut and Bearing

gmq19.eps

High Range Piston Assembly

Refer to Figure 5-12, 5-13, 5-14 and 5-15.

The High Range Piston and Cylinder is installed as follows:

1. Insert the Filter (2470-1-9), Filter Retainer (2470-1-8), and O-Ring (54-703-112) into the column as shown in Figure 5-15. The O-Ring should be lubricated with Dupont Krytox 240 Grease (45-351) before installation. All excess lubricant should be wiped off, leaving only a slight film.
2. The piston and cylinder, after they have been cleaned in accordance with the cleaning instructions in Chapter 6 and assembled per Figure 5-12, paying particular attention to the orientation of the Thrust Bearing (2470-8). Verify that the Pin Vise 90-870, has been cleaned and is free of any grease or dirt.
3. Gently clamp top end of the piston/cylinder assembly in the pin-vise as shown in Figure 5-14. Take care to clamp the vise only on the uppermost .25 inches (6 mm) of the piston.
4. Gently lift the Piston/Cylinder/Bearing assembly and place it into the column.
5. Remove the pin vise. Whenever carrying the Piston/Cylinder assembly with the pin vise, protect the piston/cylinder from damage due to falls by positioning one's free hand below the assembly as shown in Figure 5-14.
6. Tighten the Cylinder retaining cap (2470-1-4) securely by hand while holding the column with the opposite hand.
7. Before proceeding, check the level vial to verify that the base is level, adjust the level of the base if necessary.

The gauge is now ready for operation.

When working at high pressures (over 100 psi), or after reducing a high pressure to a lower pressure, the high range piston can sometimes seem sticky even if it is clean. Rotating the masses while gently bouncing the weights up and down usually frees the piston in a minute or so. However, if the piston is actually dirty, no amount of rotating or bouncing will make it perform properly. In that case the piston and cylinder must be cleaned.

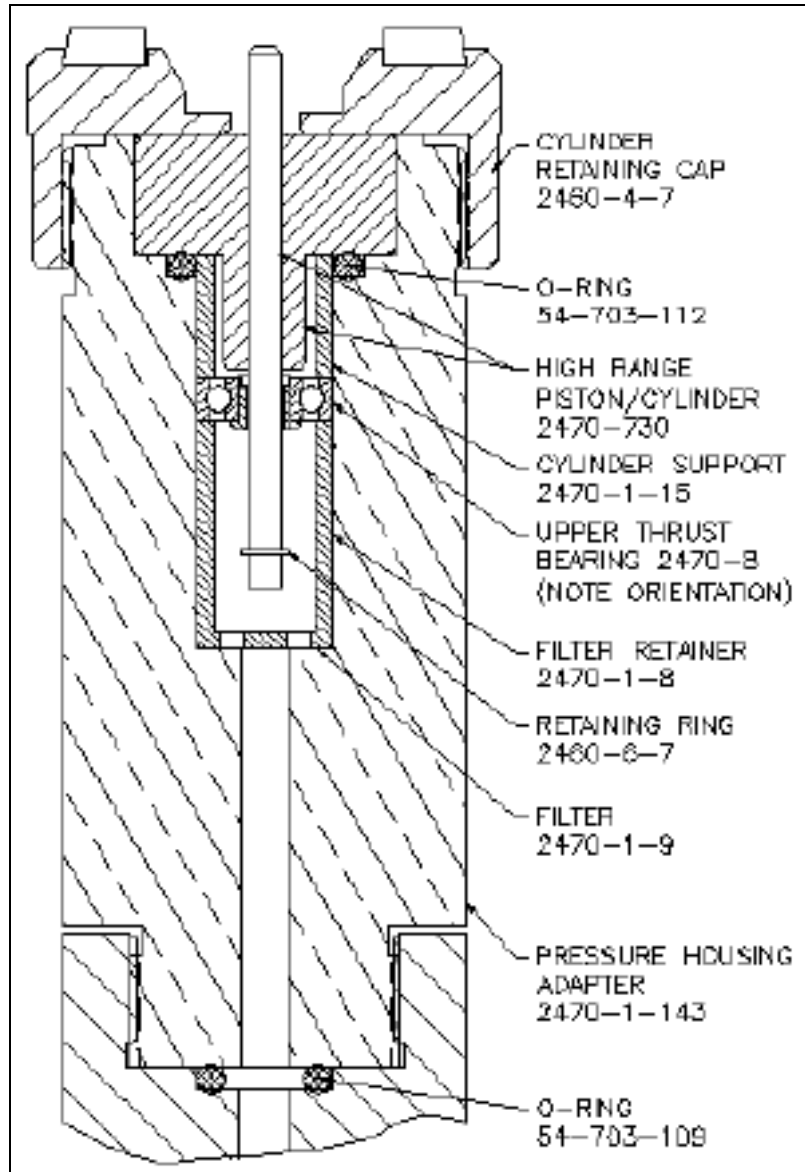

Figure 5-12. Section View, High Range Piston/Cylinder

gmq20.bmp

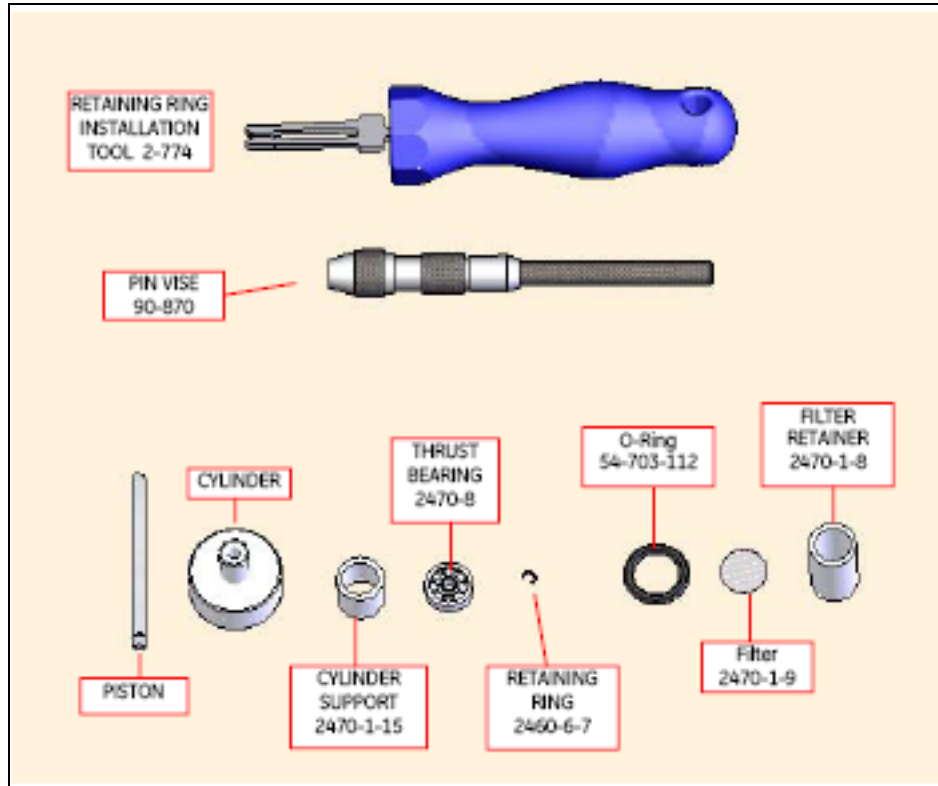

Figure 5-13. Parts Required for High Range Piston Operation

gmq21.bmp

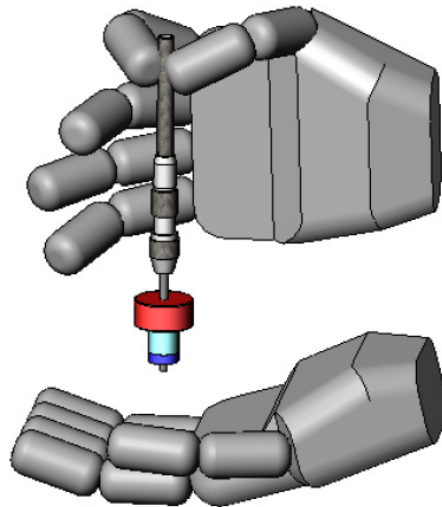

Figure 5-14. Always Use Two Hands to Carry a Piston/Cylinder Assembly

gmq22.bmp

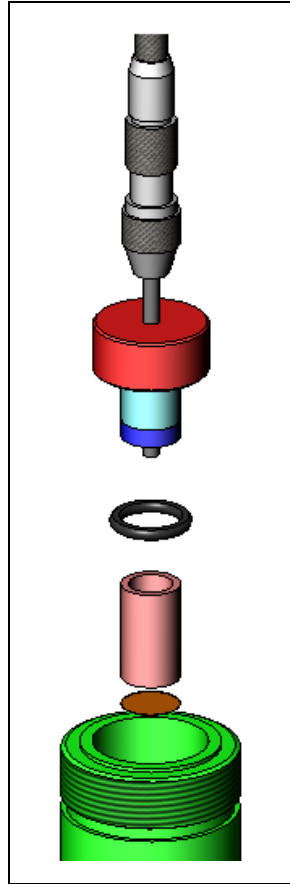

Figure 5-15. Order of Installation

gmq23.bmp

Establishing Pressure

Gauge Pressures

Pressure should be admitted slowly into the gauge, preferably through a metering valve. It is very convenient to have a volume adjusting pump such as RUSKA Series 3990 Manual Pressure Control Packs to adjust the system pressure. The RUSKA Series 3990 Manual Pressure Control Packs provides a supply gas regulator, valves, monitor gauge, and system volume adjuster all integrated into a compact package. The RUSKA Series 3990 Manual Pressure Control Packs facilitates the control of the input pressure to the gauge and provides facility to change the float position.

The index mark for the plane of reference on the RUSKA 2470 base is a circumferential groove around the base of the column. This reference is compared to the bottom face of the hanger mass as shown in Figure 5-16.

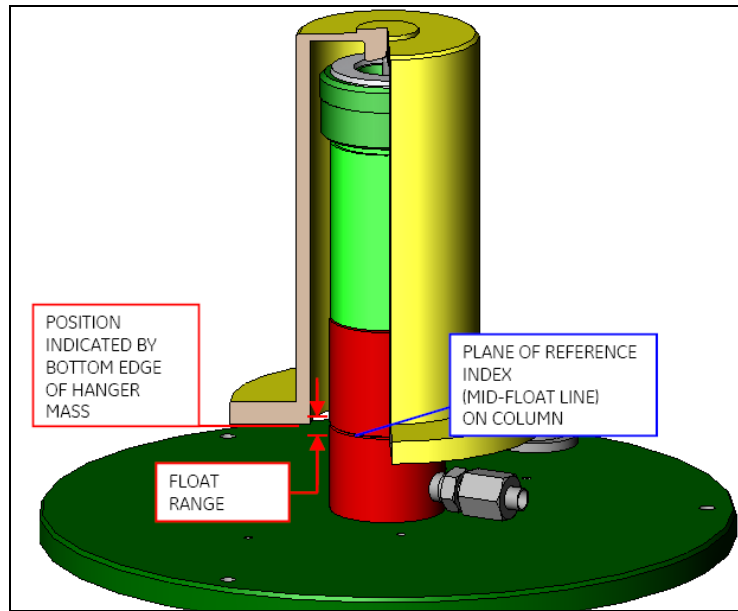

gmq08.bmp

Figure 5-16. Float Position

When the piston is floating and rotating slowly (suspended on a gas cushion between piston stops) and not oscillating and the system is at equilibrium, and the Floating position of the piston is within +/- .06 inches (1.5 mm) of the Mid-float line on the column, a reading may be taken. To reduce the variability of the process, it is a “best practice” for the metrologist to take the reading at mid-float every time.

The weights are to be rotated slowly by hand. The weights will rotate for sometime before they begin to slow. When the rotation of the weights comes to a stop, they can be rotated in the opposite direction. This allows the operator to observe any irregularities in the motion of the piston. For example, if the piston and weights begin to loose rotation speed very quickly, a dirty piston and cylinder is indicated. Chapter 6 of this manual, Piston/Cylinder Cleaning Instructions, includes detailed information for piston cleanliness checks.

A thermometer well is provided on side of the gauge base opposite the pressure fitting. If a glass thermometer is preferred, one is provided with the base. Thermometer (P/N 99291-145-28-SB) is filled with a mercury-free temperature media.

Pressure corrections for temperature, head height, Gravity, etc, are made according to the calculations and worksheets found in Appendix A.

Automating the Calculations and Data Storage

Performing the pressure correction calculations and documenting calibration data requires many redundant calculations and tedious recordkeeping. To facilitate this process and reduce the labor of these activities, the RUSKA 2456 Piston Gauge Monitor is a highly recommended. The RUSKA 2456 is equipped with a precision PRT (Platinum Resistance Thermometer) and electronic Float Position sensors.

Pressure corrections for temperature, head height, Gravity, etc, are made according to the calculations and worksheets found in Appendix A.

The RUSKA 2456 is provided with a copy of the RUSKA WinPrompt® software. The RUSKA 2456 captures real time information for float position and P/C temperature and feeds this data into the RUSKA WinPrompt® software (running on the customer’s computer). WinPrompt® automates all of the calculations performed on the Pressure Calculation worksheet noted in Appendix A.

- WinPrompt® provides simplicity and efficiency combined with accuracy and consistency in pressure generation and measurement using a deadweight gauge. It automatically converts pressure to mass and mass to pressure while correcting for piston temperature, head height, absolute and gauge references, local gravity, and air density. WinPrompt® can be operated from a single window for industrial use or from additional detailed windows available for the metrologist.

WinPrompt® Features:

- Stores calibration coefficients for working standards including piston/cylinder effective area, thermal coefficient of expansion, pressure deformation coefficients, and all calibrated mass values and associated density. It also stores all of the critical system and environmental parameters including local gravity, head corrections, and air density.
- Performs all necessary calculations of pressure-to-mass and mass-to-pressure in both S.I. and English units.
- Computes the buoyant effect of the ambient air on the piston gauge masses and compensates accordingly.
- Creates calibration procedures for performing repetitive type calibrations. Procedures include sequence of pressure values, pressure reference, corrections, and window sizes and locations.
- Captures and saves information for direct import into Microsoft Word, Microsoft Excel, and other DDE-enabled applications for custom reports. Saves all information captured during the calibration for review and re-printing of calibration reports.
- Additionally, WinPrompt® supports several interfaces to RUSKA deadweight gauges that can provide:
- Direct acquisition of float position, sink rate, piston temperature, vacuum, ambient temperature, barometric pressure, and humidity with continuous correction of calculated pressure.
- Real-time graphing of acquired values.

Leaks

Leaks in the pressure system that is used with the gauge cannot be tolerated. Small leaks cause rapid piston fall rates and can create an error in the measured pressure. Every effort should be made to insure a leak-free system.

Maintenance of the Gauge

The gauge has no moving parts other than the Piston/Cylinder assemblies. The gauge requires no maintenance other than the periodic cleaning of the piston/cylinder assemblies and replacing O-rings as necessary. O-Rings should be lightly lubricated with Dupont Krytox Grease (45-351) before installation. All excess lubricant should be wiped off, leaving only a slight film.

Chapter 6

Piston / Cylinder Cleaning Instructions

General Information and Preparation

When it is necessary to clean the Piston/Cylinder Assembly, the Piston Pressure Gauge must be partially disassembled and some of the components set aside until later. Upon removal of the internal components, a degree of risk is involved because of the possibility of exposing the parts to harmful dirt, corrosive fingerprints, and being dropped to the table or floor. The small, carbide measuring piston will not likely survive an accidental drop. The remainder of the components, if dropped, may also be damaged to the extent of sustaining raised burrs and may no longer be useable.

Each manual operation that is performed on a mechanical device is accompanied by a finite degree of damage. The damage, however small it may be for the individual operations, is cumulative. It results from the imperfect execution of each manual operation. After a given length of time, the device may be expected to fail because of performance deterioration beyond the level of tolerance. It is important, therefore, to perform the manual operations with the greatest possible skill in order to keep the harmful side effects at a minimum.

There are two types of contamination that affect not only the performance of a piston pressure gauge but also the mechanical state of the critical components. One contaminant is the ordinary hard particle of matter that scratches and abrades the finely-finished surfaces as it becomes entrapped between the close-fitting members. The scratches invariably result in raised edges from the displacement of the metal and spoil the original relationship of the members. The second type of contaminant is of a chemical nature and produces harmful effects by attacking the finished metallic surfaces in a corrosive manner. Ordinary fingerprints contain water-soluble, acidic salts, having extremely high corrosive activity with the metals of the critical instrument parts. Since these parts must necessarily be handled in making a piston exchange, they may be protected from exposure to both types of contaminants by the use of clean paper wipers.

There are a number of industrial paper wipers such as Kimwipes available that are relatively free of lint. After a little practice, the corrosion-sensitive parts may be safely handled with these wipers instead of with the bare fingers. Even when using the wipers as insulators, the hands should first be washed and thoroughly dried before beginning the disassembly.

The space allotted to the discussion of cleanliness is not intended to imply to the technician the impossibility of performing the job correctly, but rather to give him reassurance that the results will be quite satisfactory if he follows common-sense procedures of eliminating contaminations by use of proper techniques.

Being forewarned of the hazards, the technician should wipe the bench and all instrument surfaces in the vicinity of the Piston Pressure Gauge before starting disassembly operations. A wad of Kim-Wipes slightly wetted with a solvent, such as high grade alcohol or acetone will help pick up particles that invariably accumulate near the gauge.

A clean space should be prepared on a work bench. Cover this space with paper towels so that cleaned parts will not be contaminated.

REMOVE ALL PRESSURE FROM THE PISTON PRESSURE GAUGE BY VENTING THE PRESSURE HOUSING TO THE ATMOSPHERE.

Unscrew the knurled retaining cap from the top of the housing and lay it aside on a clean Kim-Wipe.

Functional Testing of Piston/Cylinder Assemblies

The piston/cylinder assembly should be tested for cleanliness and proper operation before and after each use. Perform the following steps to test for proper operation and to show that the assembly is clean.

1. Install the piston/cylinder assembly into the DWG base and secure the retaining cap.
2. Pressure the base until the piston alone is floating near mid-stroke.
3. With a gentle stroke of the finger, rotate the piston while also causing it to bounce in the cylinder. After a few strokes allow the piston to coast on its own. Although the rotation of the mid and high ranges may be lengthy, the free rotation of the low range may last only a brief few seconds. At any rate, all ranges should rotate freely with no sudden changes in rotation speed and should coast to a gradual stop. The last bit of rotation just before stopping is often the most useful in judging if the piston is functioning correctly.
4. If the piston does not perform as indicated above, it should be cleaned and retested. If the subsequent cleaning does not improve the results, the assembly may be damaged and should not be used until a qualified inspection is made as to the source of the failure.

Cleaning the Low Range Piston/Cylinder Assembly

Cleaning supplies (refer to Figure 6-1) consist of:

- Solvent, such as high grade alcohol or acetone
 - Low-lint paper wipers, such as Kimberly Clark, Kimwipes number 34155
 - Cleaning tool number 2460-56
 - Wooden applicator sticks, such as Puritan number 807-12
 - Cashmere Bouquet brand hand soap
 - Bottle brush, such as RUSKA part number 7-682
 - Size 0 rubber stopper, such as RUSKA part number 81-536
 - Warm tap water
1. Prepare a clean work area near a running tap water source.
 2. Prepare several sets of folded wipers as shown in Figures 6-2 through 6-4. Two wipers can be folded together for wiping the outside of the piston and cylinder. A single folded wiper can be inserted into, then wrapped around the cleaning tool for cleaning the bore of the cylinder.
 3. Disassemble the piston/cylinder assembly.
 4. Pre-clean the piston and cylinder using solvent soaked wipers.

5. Prepare additional wipers as necessary for drying the piston and cylinder once they have been washed with soap and water.
6. Scrub the bore of the cylinder using a soft bottle brush, Cashmere Bouquet soap and warm tap water.
7. Rinse thoroughly and dry immediately using the pre-folded wipers wrapped around the cleaning tool.
8. Set the cylinder aside and cover with a clean dry wiper.
9. Insert the rubber stopper into the bottom of the piston.
10. Using a soft paper wiper, Cashmere Bouquet soap and warm tap water, scrub the outside of the piston.
11. Rinse thoroughly and dry immediately. The rubber stopper can be removed after drying, but be careful not to touch the piston body.
12. Set the piston aside and cover with a clean dry wiper. Allow the piston and cylinder to set for about 15 minutes before reassembly.
13. Clean the upper thrust bearing and washer using solvent soaked wipers and set aside.
14. Inspect the O-ring for any sign of damage, replace as necessary.
15. Apply a slight amount of lubricant to the O-ring and wipe off any excess.
16. Place the cylinder upright (the O-ring groove at the bottom) on the work area.
17. Carefully insert the piston into the top of the cylinder and allow it to sink freely into the cylinder. Do not force the piston into the cylinder or it may be damaged. If lint becomes a problem a clean dry gas source can be used to blow the lint off of the parts prior to assembly.
18. Install the upper thrust bearing around the stem of the piston top.
19. Install the thrust washer on top of the thrust bearing.
20. Install the assembly into the instrument base and test according to Chapter 6, Functional Testing of Piston/Cylinder Assemblies section.



Figure 6-1. Materials for Cleaning Low Range Piston/Cylinder

gmq24.bmp



Figure 6-2. Preparations for Cleaning the Low Range Cylinder

gmq25.bmp



Figure 6-3. Preparing the Kim-Wipes - Step 1

gmq26.bmp



Figure 6-4. Preparing the Kim-Wipes - Step 2

gmq27.bmp



Figure 6-5. Preparing the Low Range Cleaning Tool - Step 1

gmq28.bmp



Figure 6-6. Preparing the Low Range Cleaning Tool - Step 2

gmq29.bmp

Mid Range Piston/Cylinder

Cleaning supplies (see Figure 6-7) consist of:

- Solvent, such as high grade alcohol or acetone
- Low-lint paper wipers, such as Kimberly Clark, Kimwipes number 34155.
- Cleaning tool No. 2460-70-5
- Wooden applicator sticks, such as Puritan No. 807-12.
- Cashmere Bouquet brand hand soap
- Bottle brush, such as RUSKA part number 7-681.
- Warm tap water



Figure 6-7. Materials for Cleaning the Mid Range Piston/Cylinder

gmq30.bmp



gmq31.bmp

Figure 6-8. Preparing the Mid Range Cleaning Tool

1. Prepare a clean work area near a running tap water source.
2. Prepare several sets of folded wipers as shown in Figures 6-2 through 6-4. Two wipers can be folded together for wiping the outside of the piston and cylinder. A single folded wiper can be inserted into, then wrapped around the cleaning tool for cleaning the bore of the cylinder.
3. Disassemble the piston/cylinder assembly.
4. Pre-clean the piston and cylinder using solvent soaked wipers. Prepare additional wipers as necessary for drying the piston and cylinder once they have been washed with soap and water.
5. Scrub the bore of the cylinder using a soft bottle brush, Cashmere Bouquet soap and warm tap water.
6. Rinse thoroughly and dry immediately using the pre-folded wipers wrapped around the cleaning tool.
7. Set the cylinder aside and cover with a clean dry wiper.
8. Using a soft paper wiper, Cashmere Bouquet soap and warm tap water, scrub the outside of the piston.
9. Rinse thoroughly and dry immediately.
10. Set the piston aside and cover with a clean dry wiper. Allow the piston and cylinder to set for about 15 minutes before reassembly.
11. Clean the thrust bearing, retaining nut, upper retaining ring and lower o-ring spacer using solvent soaked wipers and set aside.
12. Inspect the o-rings for any sign of damage, replace as necessary.
13. Apply a slight amount of lubricant to the o-rings and wipe off any excess.
14. Place the cylinder upright on the work area.
15. Carefully insert the piston into the top of the cylinder and allow it to sink freely into the cylinder. Do not force the piston into the cylinder or it may be damaged.

16. If lint becomes a problem a clean dry gas source can be used to blow the lint off of the parts prior to assembly.
17. Install the thrust bearing around the bottom of the piston.
18. Install the retaining nut on the bottom of the piston and tighten by hand. Do not use wrenches to tighten the nut.
19. Install the O-ring spacer and O-rings into the instrument base.
20. Install the assembly into the instrument base and test according to Chapter 6, Functional Testing of Piston/Cylinder Assemblies.

Cleaning the High Range Piston/Cylinder Assembly

Cleaning supplies (refer to Figure 6-9) consist of:

- Solvent, such as high grade alcohol or acetone
- Low-lint paper wipers, such as Kimberly Clark, Kimwipes number 34155
- Retaining Ring Installation Tool, such as RUSKA part number 2-774
- Wooden applicator sticks, such as Puritan number 807-12
- Pin Vise such as RUSKA part number 90-870(1)
- Cashmere Bouquet brand hand soap
- Bottle brush, such as RUSKA part number 7-680
- Warm tap water



Figure 6-9. Materials for Cleaning the High Range Piston Cylinder

gmq32.bmp

1. Prepare a clean work area near a running tap water source.
2. Prepare several sets of folded wipers as shown in Figures 6-2 through 6-4. Two wipers can be folded together for wiping the outside of the piston and cylinder. Prepare several twisted wipers as shown in Figures 6-10 through 6-12 to wipe the bore of the cylinder.
3. Disassemble the piston/cylinder assembly.
4. Insert the retaining clip from the bottom of the piston into the installation tool, rinse with solvent and set aside.

5. Pre-clean the piston and cylinder using solvent soaked wipers.
6. Prepare additional wipers as necessary for drying the piston and cylinder once they have been washed with soap and water.
7. Scrub the bore of the cylinder using a soft bottle brush, Cashmere Bouquet soap and warm tap water.
8. Rinse thoroughly and dry immediately using the pre-twisted wipers.
9. Set the cylinder aside and cover with a clean dry wiper.
10. Using soft paper wiper, Cashmere Bouquet soap and warm tap water, scrub the outside of the piston.
11. Rinse thoroughly and dry immediately.
12. Set the piston aside and cover with a clean dry wiper. Allow the piston and cylinder to set for about 15 minutes before reassembly.
13. Clean the thrust bearing, cylinder container and upper retaining ring using solvent soaked wipers and set aside.
14. Inspect the o-rings for any sign of damage, replace as necessary.
15. Apply a slight amount of lubricant to the o-rings and wipe off any excess.
16. Place the cylinder upright (narrow neck downward) on the work area.
17. Carefully inset the piston into the top of the cylinder and allow it to sink freely into the cylinder. Do not force the piston into the cylinder or it may be damaged.
18. If lint becomes a problem a clean dry gas source can be used to blow the lint off of the parts prior to assembly.
19. Install the thrust bearing around the bottom of the piston with the flange of the outer race facing the bottom of the cylinder.
20. Install the retaining clip onto the bottom of the piston using the installation tool. The end of the piston must be supported during the retaining clip installation so as not to risk breaching the piston.
21. Install the assembly into the instrument base and test according to Chapter 6, Functional Testing of Piston/Cylinder Assemblies.
22. Prior to using the pin vise, be sure it is clean and in good working order. Disassemble the pin vise and clean the components with solvent soaked wipers.



Figure 6-10. Preparing the Kim Wipe for Cleaning the High Range Cylinder - Step 1

gmq33.bmp

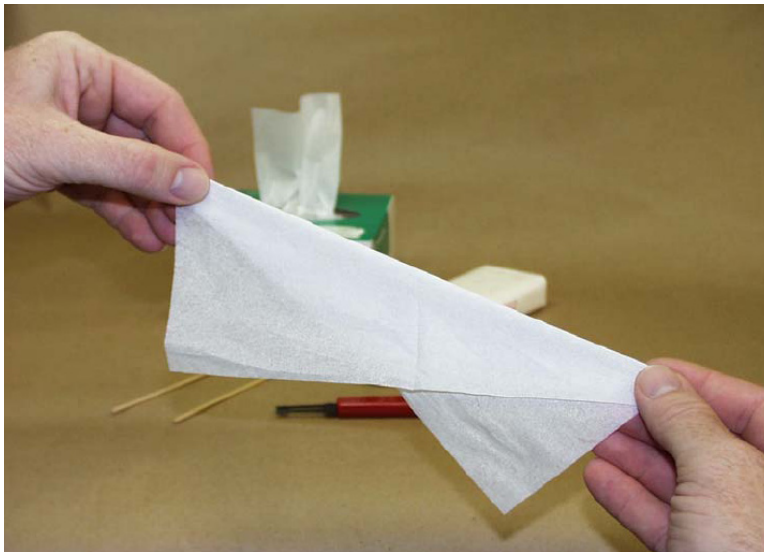

Figure 6-11. Preparing the Kim Wipe for Cleaning the High Range Cylinder - Step 2

gmq34.bmp



Figure 6-12. Preparing the Kim Wipe for Cleaning the High Range Cylinder - Step 3

gmq35.bmp



Figure 6-13. Cleaning the High Range Cylinder

gmq36.bmp



Figure 6-14. Drying the High Range Cylinder

gmq37.bmp

Appendix A

Explanation of "Pressure Calculation Worksheet"

Introduction

See Tables at the end of this appendix.

These tables may be used with gas and hydraulic piston pressure gauges that are operated with an atmospheric reference or vacuum reference. P_A represents the pressure at the piston reference gauge level, P_B represents the pressure desired at the device under test, and P_H is the head pressure created by the pressure medium and the difference in height between the piston pressure gauge and the device under test.

- A. A minimum of six significant figures must be used in all calculations involving reported constants, masses, etc. The manufacturer's claims for accuracy assume the local gravity to be known to at least six significant figures
- B. When the piston pressure gauge is used as a standard of pressure, it is convenient to perform the pressure-to-mass calculations in advance of operating the standard. Since the piston gauge temperature fluctuates while it is operated, a confusing point in the procedure is the necessity for the temperature of the gauge to be predicted prior to operation. This "expected temperature" however is used to allow the pressure calculations to be performed. Once the piston pressure gauge is floating at the intended pressure, a final temperature observation is made and then "trim" masses are loaded onto the piston gauge to correct for any temperature variations that exist between the expected and the actual temperatures. The final column in the worksheet is used to calculate the temperature coefficient, which defines the amount of trim that is required to correct for this temperature change.

It is usually prudent to select an expected temperature (t), which is lower than any temperature that will be experienced. This is so that the operator can always add mass to correct for the actual temperature. Adding mass is generally more convenient than subtracting mass from the planned loading arrangement. Standard metric trim mass set is entirely suitable for this purpose.

All of the calculations will be performed to this expected temperature (t). A final trim would be calculated to adjust the piston gauge to the temperature of the piston at the time of the actual measurement. This correction is calculated in the last column of the worksheet. This column represents the number of grams to be added to the stack of masses for a difference in the actual temperature from the expected temperature, (t). The final trim is computed using the following formula and loaded onto the piston gauge;

$$\text{“Temp. Coef.”} \times (\text{actual temperature} - \text{expected temperature})$$

- C. The Symbol $A_{o(t)}$ represents the effective area of the piston and its cylinder at atmospheric pressure, when operating at temperature (t); it is obtained from the relation

$$A_{o(t)} = A_{o(23)} (1 + c \Delta t)$$

where:

$$\begin{aligned} A_{o(23)} &= \text{reported area of the piston at 23 degrees Celsius} \\ c &= \text{thermal coefficient of superficial expansion} \\ \Delta t &= (t - 23) \end{aligned}$$

- D. Gravity and Buoyancy Correction: When the masses are applied to the piston in the presence of the buoyant atmosphere, buoyancy corrections are necessary and are combined with gravity corrections. For convenience, the combined correction K_1 (or K_2) is applied as a multiplier with the result indicating the quantity of apparent mass that is required to produce the desired force (F) on the piston.

For English Units

$$K_1 = (g_s / g_1) [\rho_{am} / (\rho_{am} - \rho_{air})]$$

where:

$$\begin{aligned} g_s &= \text{acceleration due to standard gravity, } 980.665 \text{ cm/sec}^2 \\ g_1 &= \text{acceleration due to local gravity in cm/sec}^2 \\ \rho_{air} &= \text{density of air in g/cm}^3; \text{ see Equation A-4} \\ \rho_{am} &= \text{density of apparent mass;} \\ &\quad \text{for Apparent Mass versus Brass, } 8.4 \text{ g/cm}^3 \\ &\quad \text{for Apparent Mass versus Stainless Steel, } 8.0 \text{ g/cm}^3 \end{aligned}$$

When selecting masses from the calibration report, assure that the values selected are in the same Apparent Mass unit of measure that was used to calculate the K_1 or K_2 values.

The apparent mass (Column 9) is obtained from:

$$M_A = F K_1$$

where:

$$\begin{aligned} M_A &= \text{apparent mass; record in Column 9} \\ F &= \text{force required on piston; as found in Column 8} \\ K_1 &= \text{multiplier which was determined by previous equation} \end{aligned}$$

For SI Units:

$$K_2 = 1/[g_1(1 - \rho_a / \rho_b)]$$

where:

g_1 = acceleration due to local gravity in m/sec²

ρ_{air} = density of air in g/cm³; see Equation A-4

ρ_{am} = density of apparent mass;

for Apparent Mass versus Brass, 8.4 g/cm³

for Apparent Mass versus Stainless Steel, 8.0 g/cm³

When selecting masses from the calibration report, assure that the values selected are in the same Apparent Mass unit of measure that was used to calculate the K_1 or K_2 values.

The apparent mass (Column 9) is obtained from:

$$M_A = F K_2$$

where:

M_A = apparent mass versus brass; record in Column 9

F = force required on piston; as found in Column 8

K_2 = multiplier which was obtained by previous equation

When the masses are applied to the piston in an evacuated bell jar, the above equations for K_1 and K_2 can still be used. In this situation, the density of air (ρ_{air}) will be zero which will cause the buoyancy portion of the equation to become 1. Also, the results will indicate the quantity of true mass (not apparent mass) that must be applied to the piston.

- E. Column 1, P_B , is the desired pressure at the reference plane of the device being calibrated.
- F. Column 2 is the mass density of the pressure medium being used in the piston pressure gauge system. For hydraulic piston pressure gauges, this number can be considered constant for all pressures. RUSKA Instrument has two types of hydraulic piston fluids available. One is a Spinesstic 22™ part number 55-500 which has a density of 0.031 pounds per cubic inch (858 kilograms per cubic meter). The other is a Dioctyl Sebacate (DOS) part number 55-521-1 which has a density of 0.033 pounds per cubic inch (913 kilograms per cubic meter). For gas medium piston gauges, the values in Column 2 will be different for different system pressures. Equations are provided to calculate the density of air or nitrogen as a function of the system pressure.
- G. Column 3 is required to adjust the mass density of the pressure medium for local gravity. It is also used to correct the pressure head that exist between the reference ports of the piston gauge and device under test.
- H. Column 4, P_H , is the pressure correction that is required if the reference plane of the device being calibrated is not the same plane as the reference plane of the piston pressure gauge. The difference between the two planes, h, is positive if the reference plane of the device being calibrated is higher than the reference plane of the piston pressure gauge.

- I. Column 5 is the pressure required at the reference plane of the piston pressure gauge to produce the desired pressure at the reference plane of the device being calibrated. When the piston gauge is operating in the absolute mode, the Reference pressure, P_R , is subtracted to obtain the differential pressure that the piston is required to generate.
- J. The value of $1 + b_1P_A + b_2P_A^2$, which is used to determine the piston area at different system pressures, is recorded in column 6. For some pistons, b_1 and/or b_2 are equal to zero. Always observe the sign in front of b_1 and b_2 as found in the calibration report.
- K. Column 7 is used to record $A_{e(t)}$ which is the area of the piston at pressure P_A and at the expected temperature (t).
- L. Column 8, the weight load, is the force required on a piston of given area to produce a given pressure

$$F = P_A A_{e(t)}$$

where:

- F = Weight load or force on the piston
- P_A = Pressure as indicated in Column 5
- $A_{e(t)}$ = Effective piston area at the expected temperature (t).

- M. Column 9 is the apparent mass that is required to produce the force listed in Column 8.
- N. Column 10 is a listing of the different masses to be loaded on the piston pressure gauge to create the pressure listed in Column 5. The masses which will be listed here are in addition to the **tare** components (piston, surface tension effects, bell jar reference pressure, etc.). The mass of the tare components must be subtracted from the mass shown in Column 9 before selection of the miscellaneous masses is started.

After subtracting the TARE mass from the Total Mass shown in Column 9, we must now subdivide/distribute the remaining required mass value among the available masses that will be loaded onto the Piston Table Assembly. It is most likely that there may be many combinations of available masses that could be used to yield the required Total Mass. However, it is strongly recommended that an orderly and sequential method be used. From the Mass Set Table (calibration report) first determine if the Sleeve Mass is required (which would be the case if the realization of the Total Mass value would require the use of the larger platter masses). If yes, then subtract its mass value from the Total Mass value which results in a new "remainder". From this "remainder" mass value, choose the next largest available mass value that may be subtracted. If the choice is from one of several "nominal" mass platters then choose the first one in the available sequence. Subtract this value from the "remainder", which now results in another new "remainder" mass value. Continue this process until the "remainder", which now results in another new "remainder" mass value. Continue this process until the "remainder" is smaller than the smallest available mass from the mass set. At every step, record the selected mass (its mass ID number) into Column 10.

- O. Column 11, the remainder from Column 10, is the mass that must be placed on the piston pressure gauge to complete the mass needed to set the desired pressure. This "remainder", recorded in Column 11, is realized with the Trim Mass set provided with all RUSKA Mass Sets. The RUSKA supplied Trim Mass Sets are defined as Class 3, Type 1 (per ASTM E617, formerly Class S1 per NBS Cir. 547).

These fractional masses should also be used to adjust the mass load for piston pressure gauge operating temperatures that differ from the expected temperature (t). These fractional masses could also be used to adjust the mass load for the piston pressure gauge if the reference plane of the device being calibrated is at a different elevation than planned in the original head correction.

- P. In the English system, the remainder can be recorded in pounds in Column 11, and in grams in Column 12. The conversion factor to convert pound mass to grams is 453.59237 g/lbm.
- Q. Column 13 is used to calculate a temperature coefficient. This temperature coefficient is used to correct for any piston temperature variation from the expected temperature value that was used to calculate the mass loads for the various pressure points in the worksheet. See item B above.

PISTON PRESSURE GAUGE PRESSURE CALCULATION WORKSHEET (SI UNITS)

Date _____ Expected Temperature, (t) _____ °C

Reference Plane Difference, h _____ m $A_{0(t)} = A_{0(23)} [1 + c(t-23^\circ\text{C})]$ _____ m²

Mass Set Serial No. _____ Local Gravity, g_L _____ m/sec²

Piston Serial No. _____ Air Density, ρ_{air} _____ kg/m³

$A_{0(23)} = A_0$ at 23 °C _____ m² Gravity & Buoyancy, K₂ _____ Gravity & Buoyancy, K₂ _____ kg

b₁ _____ /MPa _____ /Pa Tare, Mass _____ kg

b₂ _____ /Mpa₂ _____ /Pa² Reference Pressure, P_R _____ mtorr Pa

c _____ /°C _____ Pa

1	2	3	4	5	6	7	8	9	10	11	12
P _B NOMINAL PRESSURE	ρ_{medium} (Mass Density)	$\rho_w =$ ($\rho_{\text{medium}} - \rho_{\text{air}}$) kg/m ³ x g _L	P _H = $\rho_w \times h$	P _A = P _B + P _H - P _R	$1 + b_1 P_A$ + $b_2 P_A^2$	$A_{e(t)} =$ $A_{0(t)} \times$ Column 6	F = $P_A \times A_{e(t)}$	M = F x K ₂	Masses to be used	Remainder	Temp. Coef. = Column 9 x 1000g/kg x c
Pa	kg/m ³	N/m ³	Pa	Pa		m ²	N	kg	Tare Plus	grams	g/°C

Appendix B

Equation A-4 — Air Density

Equation A-4 — Air Density

Air Density (P_{AIR}) in units of g/cm^3 , is calculated as follows;

$$\rho_{air} = \left(0.0004646 \times (P - 4990221.6 \times U \times e^{(-5315.56/(273.15 + t))})\right) / (273.15 + t)$$

where:

P = Barometric Pressure, (mmHg)

t = Air Temperature, ($^{\circ}\text{C}$)

U = Relative Humidity, (%RH)

Nitrogen Density — English Units (0 to 1000 PSIG)

To calculate the density of Nitrogen at pressures from 0 psig to 1000 psig, use the following equation;

$$DENSITY \left(\text{lbm} / \text{in}^3\right) = \left(2.826 \times 10^{-6}\right) \times P$$

where;

$P = PRESSURE$ in psi absolute (if P is in gauge, convert it to an absolute value by adding barometric pressure, e.g. $P + 14.7$)

Nitrogen Density — English Units (1,000 to 15,000 PSIG)

To calculate the density of Nitrogen at pressures from 1,000 psig to 15,000, use the following equation;

$$DENSITY \left(\text{lbm} / \text{in}^3\right) = \left(2.37465 \times 10^{-4}\right) + \left(2.74396 \times 10^{-6}\right)P - \left(9.46069 \times 10^{-11}\right)P^2$$

where;

$P = PRESSURE$ in psi absolute (if P is in gauge, convert it to an absolute value by adding barometric pressure, e.g. $P + 14.7$)

Nitrogen Density — SI Units (0 to 6.9 MPa)

To calculate the density of Nitrogen at pressures from 0.01 MPa gauge to 6.9 MPa, use the following equation;

$$DENSITY (kg / m^3) = (1.1347 E - 05) \times P$$

where;

$P = PRESSURE$ in Pa absolute (if P is in gauge, convert it to Pa absolute by adding barometric pressure, e.g. $P + 101325$)

Nitrogen Density — SI Units (6.9 MPa to 100 MPa)

To calculate the density of Nitrogen at pressures from 6.9 MPa gauge to 100 MPa, use the following equation;

$$DENSITY (kg / m^3) = 6.573 + (11.016)P - (0.055087)P^2$$

where;

$P = PRESSURE$ in MPa absolute (if P is in gauge, convert it to MPa absolute by adding barometric pressure, e.g. $P + 101325$)

Zero Air Density — SI Units (0 MPa to 20.7 MPa)

To calculate the density of Zero Air at pressures to 20.7 MPa, use the following equation;

$$DESNSITY (kg / m^3) = (1.17 E - 05) \times P$$

where;

$P = PRESSURE$ in Pa absolute (if P is in gauge, convert it to Pa absolute by adding barometric pressure, e.g. $P + 101325$)

Helium Density — SI Units (0 to 6.9 MPa)

To calculate the density of Nitrogen at pressures from 0.01 MPa gauge to 6.9 MPa, use the following equation;

$$DENSITY (kg / m^3) = (1.585 E - 06) \times P$$

where;

$P = PRESSURE$ in Pa absolute (if P is in gauge, convert it to Pa absolute by adding barometric pressure, e.g. $P + 101325$)

Helium Density — SI Units (6.9 MPa to 100 MPa)

To calculate the density of Nitrogen at pressures from 6.9 MPa gauge to 100 MPa, use the following equation;

$$DENSITY (kg / m^3) = 0.3136 E - 01 + (1.508)P - (3.886 E - 03)P^2$$

where;

$P = PRESSURE$ in MPa absolute (if P is in gauge, convert it to MPa absolute by adding barometric pressure, e.g. $P + 0.101325$)

Conversion Factors

Table B-1. Conversion Factors

To Convert From	To	Multiply By
Pa	N/m ²	1
N/m ²	Pa	1
Pa	MPa	10 ⁻⁶
MPa	Pa	10 ⁶
N/m ²	MPa	10 ⁻⁶
MPa	N/m ²	10 ⁶
Pa	PSI	1.450377 X 10 ⁻⁴
PSI	Pa	6894.76
MPa	PSI	145.0377
PSI	MPa	6.89476 X 10 ⁻³

Where:

- Pa = pascal
- MPa = megapascal
- N = newton
- M = meter
- PSI = pounds per square inch

Appendix C

Glossary

Glossary

Ao

Effective area of the piston/cylinder at zero pressure and at the reference temperature.

Absolute

Pressure measurement referenced to absolute vacuum. See also Gauge.

Apparent Mass Reference Density

Density used to computer Apparent Mass values.

b1

Linear coefficient of elastic distortion.

b2

Quadratic coefficient of elastic distortion.

Buoyancy

An object submerged in a fluid is buoyed up by the fluid. The air surrounding the deadweight gauge masses reduces the downward force acting on the piston. The equilibrium pressure acting on the bottom of the piston is also less. The buoyant effect of "normal" air acting on stainless steel deadweight gauge masses reduces the pressure by approximately 0.015% or 150 parts per million. See also Mass Apparent; Reference Density; and Density of Air.

c

Coefficient of thermal expansion.

Constant

Allows entry of a fixed value for the variable.

Cross Float

The calibration of one Deadweight Gauge against another Deadweight Gauge.

D

Reference dimension for the hanger mass.

Density, Air

Density of the air used to computer the buoyant effect of air on the masses. May be entered directly or computed from ambient temperature, humidity and pressure.

Density, Gas

Density of the gas medium used to compute head corrections. Gas density may be entered directly or may be computed from the gas used and the current pressure.

Density, Oil

Density of the oil medium used to compute head corrections. Oil density may be entered directly or may be selected from the list of available mediums.

Density, True

The actual density (mass per unit volume) of the mass or piston. See also Reference Density; Density of Air; and Mass Apparent.

DUT

Device under test, the device being calibrated.

English Units:

Pressure	psi
Ao	in ²
b1	in ² /in ² /psi
b2	in ² /in ² /psi ²
c	in ² /in ² /°C
Mass	lbm
Head Height	in
Elevation	ft
Length	in
Sink Rate	in/min
Vacuum	microns
Temperature	°C
Trim	g
Gravity	cm/sec ²
Density	g/cm ³
Humidity	% RH

Elevation

Elevation above sea level for computing approximate Gravity.

Float Position

Distance of the piston from mid-float. Positive values are higher, negative values are lower than mid-float.

Formula

Calculates the variable using other variables. See Gravity; Air Density.

Gauge

Pressure measurement referenced to current atmospheric pressure.

Gravity

Force of gravity on the masses. May be entered directly or computed from Latitude and Elevation.

Gravity Factor

Mass correction factor for local gravity.

Head Height

Vertical distance between reference planes. A positive value indicates the Device Under Test is higher than the standard.

Head Correction

Pressure correction for head height.

Humidity

Current ambient relative humidity. Used to compute air density if not entered as a constant.

+INF, -INF

Infinity. The number is bigger than can be represented. Computing altitude at zero pressure will give this value.

L1

Distance from the top of the mass loading surface to the bottom of the piston.

Latitude

Distance from the equator in degrees and minutes of latitude. Used to compute local gravity if not entered as a constant.

Mass, Apparent

May be Apparent Mass versus Brass Standards or Apparent Mass versus Steel Standards. An expression of the effective mass of a given object with an assumed density, typically that of the standard used to measure the mass value. In a practical sense, Apparent Mass versus Brass Standards describes what an object appears to weigh when compared to a brass standard in the presence of a buoyant atmosphere. See also Buoyancy; Reference Density; True Mass; and Density of Air.

Mass, Nominal

Pressure converted to mass before corrections are applied.

Mass, Tare

Mass of the least number of components required to generate a pressure, in many cases the piston only.

Mass, Total

Mass used to generate a pressure. Included both platter masses and trim masses.

Mass, Trim

Small masses used to generate an exact pressure.

Mass, True

A quantitative expression of the amount of matter in an object. See also Mass Apparent

Mass Set File

Contains all information for a mass set.

Medium

The fluid or gas used to generate pressure.

+NAN, -NAN

Not A Number. The value cannot be computed (i.e., division by zero).

Piston/Cylinder File

Contains all information for a single piston/cylinder set.

Pressure, Ambient

Local atmospheric pressure.

Pressure, Corrected

Pressure after corrections have been applied.

Pressure Factor

Correction for the effect of pressure on the area of the piston.

Pressure Units:

MPa	Megapascals
kPa	kilopascals
hPa	hectopascals
Pa	Pascals
bar	bars
psi	pounds per square inch
kg/cm ²	kilograms per square centimeter
mmHg 0°C	millimeters of mercury at 0 °C
cmHg 0°C	centimeters of mercury at 0 °C
inHg 0°C	inches of mercury at 0 °C
inHg 60°F	inches of mercury at 60 °F
cmH ₂ O 4°C	centimeters of water at 4 °C
inH ₂ O 4°C	inches of water at 4 °C
inH ₂ O 20°C	inches of water at 20 °C
inH ₂ O 25°C	inches of water at 25 °C
feet	feet of altitude
meters	meters of altitude
knots	airspeed knots
km/hr	airspeed kilometers per hour

Reference Density

Assumed density of the mass standard used to calibrate the mass. For mass values reported under the designation Apparent Mass versus Brass Standards, the Reference Density is typically 8.4 g/cm³. For the designation Apparent Mass versus Stainless Steel Standards, the Reference Density is typically 8.0 g/cm³. The appropriate value must be used for the Reference Density to achieve proper buoyancy corrections for gauge mode operation. For more information see Mass True; Mass Apparent.

Reference Pressure

The pressure all other pressures are measured against. See Absolute; Gauge.

Requires

Indicates what other mass (e.g. hanger mass) is required before the selected mass can be loaded onto the piston.

Rotation

Direction the masses are rotating when measurement is taken.

SI Units:

Pressure	MPa
Ao	m ²
b1	m ² /m ² /MPa
b2	m ² /m ² /MPa ²
c	m ² /m ² /°C
Mass	kg
Head Height	cm
Elevation	m
Length	m
Sink Rate	cm/min
Vacuum	mtorr
Temperature	°C
Trim	g
Gravity	cm/sec ²
Density	g/cm ³
Humidity	% RH

Sink Rate

Rate of descent of piston into cylinder.

Sleeve Mass Offset

Offset is used when a low mass sleeve is used and is loaded with additional masses.

Standard Deadweight Gauge (Dwg A)

Known gauge that other devices are compared against.

Temperature, Ambient

Temperature of the room.

Temperature, DWG

Temperature of the gas or oil measured at the deadweight gauge.

Temperature Factor

Correction for the effect of temperature on the area of the piston.

Temperature, Reference

Temperature selected by manufacturer for reporting piston/cylinder area.

Test Deadweight Gauge (Dwg B)

Unknown gauge in a cross-float calibration.

True Density

Actual density of the mass or piston.

True Mass

Mass based on actual material density as if weighted in vacuum; a.k.a. Newtonian Mass.

Uncertainty

The amount of possible error in the value.

Vacuum

The difference between absolute vacuum and the vacuum actually used.

