



# OWNER'S GUIDE

MODEL SERIES

147Y834P401

147W834H401

HYDROSTATIC TRACTORS

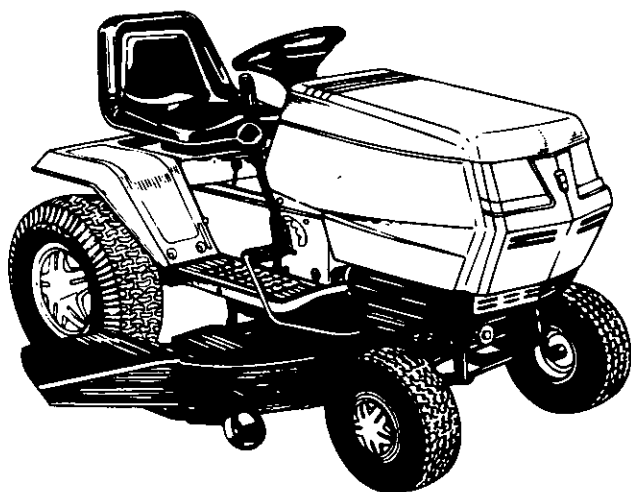

## IMPORTANT: READ SAFETY RULES AND INSTRUCTIONS CAREFULLY

**Warning:** This unit is equipped with an internal combustion engine and should not be used on or near any unimproved forest-covered, brush-covered or grass-covered land unless the engine's exhaust system is equipped with a spark arrester meeting applicable local or state laws (if any). If a spark arrester is used, it should be maintained in effective working order by the operator. In the State of California the above is required by law (Section 4442 of the California Public Resources Code). Other states may have similar laws. Federal laws apply on federal lands. A spark arrester for the muffler is available through your nearest engine authorized service dealer or contact the service department, P.O. Box 368022 Cleveland, Ohio 44136-9722.

**MTD PRODUCTS INC. P.O. BOX 368022 CLEVELAND, OHIO 44136-9722**

# IMPORTANT

## SAFE OPERATION PRACTICES

THIS SYMBOL POINTS OUT IMPORTANT SAFETY INSTRUCTIONS WHICH, IF NOT FOLLOWED, COULD ENDANGER THE PERSONAL SAFETY AND/OR PROPERTY OF YOURSELF AND OTHERS. READ AND FOLLOW ALL INSTRUCTIONS IN THIS MANUAL BEFORE ATTEMPTING TO OPERATE YOUR UNIT. WHEN YOU SEE THIS SYMBOL—  **HEED ITS WARNING.**

 **DANGER:** Your lawn mower was built to be operated according to the rules for safe operation in this manual. As with any type of power equipment, carelessness or error on the part of the operator can result in injury. This lawn mower is capable of amputating hands and feet and throwing objects. Failure to observe the following safety instructions could result in serious injury or death.

### I. GENERAL OPERATION

1. Read, understand, and follow all instructions in the manual and on the machine before starting. Keep this manual in a safe place for future and regular reference and for ordering replacement parts.
2. Only allow responsible individuals familiar with the instructions to operate the machine. Know controls and how to stop the machine quickly.
3. Do not put hands or feet under cutting deck or near rotating parts.
4. Clear the area of objects such as rocks, toys, wire, etc., which could be picked up and thrown by the blade. A small object may have been overlooked and could be accidentally thrown by the mower in any direction and cause injury to you or a bystander. To help avoid a thrown objects injury, keep children, bystanders and helpers at least 75 feet from the mower while it is in operation. Always wear safety glasses or safety goggles during operation or while performing an adjustment or repair, to protect eyes from foreign objects. Stop the blade(s) when crossing gravel drives, walks or roads.
5. Be sure the area is clear of other people before mowing. Stop machine if anyone enters the area.
6. Never carry passengers.
7. Disengage blade(s) before shifting into reverse and backing up. Always look down and behind before and while backing.
8. Be aware of the mower and attachment discharge direction and do not point it at anyone. Do not operate the mower without either the entire grass catcher or the chute guard in place.
9. Slow down before turning. Operate the machine smoothly. Avoid erratic operation and excessive speed.
10. Never leave a running machine unattended. Always turn off blade(s), place transmission in neutral, set park brake, stop engine and remove key before dismounting.
11. Turn off blade(s) when not mowing.
12. Stop engine and wait until blade(s) comes to a complete stop before (a) removing grass catcher or unclogging chute, or (b) making any repairs, adjusting or removing any grass or debris.
13. Mow only in daylight or good artificial light.
14. Do not operate the machine while under the influence of alcohol or drugs.
15. Watch for traffic when operating near or crossing roadways.
16. Use extra care when loading or unloading the machine into a trailer or truck. This unit should not be driven up or down a ramp onto a trailer or truck under power, because the unit could tip over, causing serious personal injury. The unit must be pushed manually on a ramp to load or unload properly.
17. Never make a cutting height adjustment while engine is running if operator must dismount to do so.
18. Wear sturdy, rough-soled work shoes and close-fitting slacks and shirts. Do not wear loose fitting clothes or jewelry. They can be caught in moving parts. Never operate a unit in bare feet, sandals, or sneakers.
19. Check overhead clearance carefully before driving under power lines, wires, bridges or low hanging tree branches, before entering or leaving buildings, or in any other situation where the operator may be struck or pulled from the unit, which could result in serious injury.

20. Disengage all attachment clutches, thoroughly depress the brake pedal, and shift into neutral before attempting to start engine.
21. Your mower is designed to cut normal residential grass of a height no more than 10". Do not attempt to mow through unusually tall, dry grass (e.g., pasture) or piles of dry leaves. Debris may build up on the mower deck or contact the engine exhaust presenting a potential fire hazard.

### II. SLOPE OPERATION

 Slopes are a major factor related to loss of control and tip-over accidents which can result in severe injury or death. All slopes require extra caution. If you cannot back up the slope or if you feel uneasy on it, do not mow it.

For your safety, use the slope gauge included as part of this manual to measure slopes before operating this unit on a sloped or hilly area. If the slope is greater than 15° as shown on the slope gauge, do not operate this unit on that area or serious injury could result.

#### DO:

Mow up and down slopes, not across.  
Remove obstacles such as rocks, limbs, etc.  
Watch for holes, ruts or bumps. Uneven terrain could overturn the machine. **Tall grass can hide obstacles.**  
Use slow speed. Choose a low enough gear so that you will not have to stop or shift while on the slope. Always keep machine in gear when going down slopes to take advantage of engine braking action. Follow the manufacturer's recommendations for wheel weights or counterweights to improve stability.  
Use extra care with grass catchers or other attachments. These can change the stability of the machine.  
Keep all movement on the slopes **slow** and **gradual**. Do not make sudden changes in speed or direction. Rapid engagement or braking could cause the front of the machine to lift and rapidly flip over backwards which could cause serious injury.  
Avoid starting or stopping on a slope. If tires lose traction, disengage the blade(s) and proceed slowly **straight** down the slope.

#### DO NOT:

**Do not** turn on slopes unless necessary; then, turn slowly and gradually downhill, if possible.  
**Do not** mow near drop-offs, ditches or embankments. The mower could suddenly turn over if a wheel is over the edge of a cliff or ditch, or if an edge caves in.  
**Do not** mow on wet grass. Reduced traction could cause sliding.  
**Do not** try to stabilize the machine by putting your foot on the ground.  
**Do not** use grass catcher on steep slopes.

### III. CHILDREN

 Tragic accidents can occur if the operator is not alert to the presence of children. Children are often attracted to the machine and the mowing activity. Never assume that children will remain where you last saw them.

1. Keep children out of the mowing area and in watchful care of an adult other than the operator.
2. Be alert and turn machine off if children enter the area.
3. Before and when backing, look behind and down for small children.

(continued on page 5)

# SLOPE GAUGE

(Keep this sheet in a safe place for future reference.)

USE THIS SHEET AS A GUIDE TO DETERMINE SLOPES WHERE YOU MAY NOT OPERATE SAFELY.

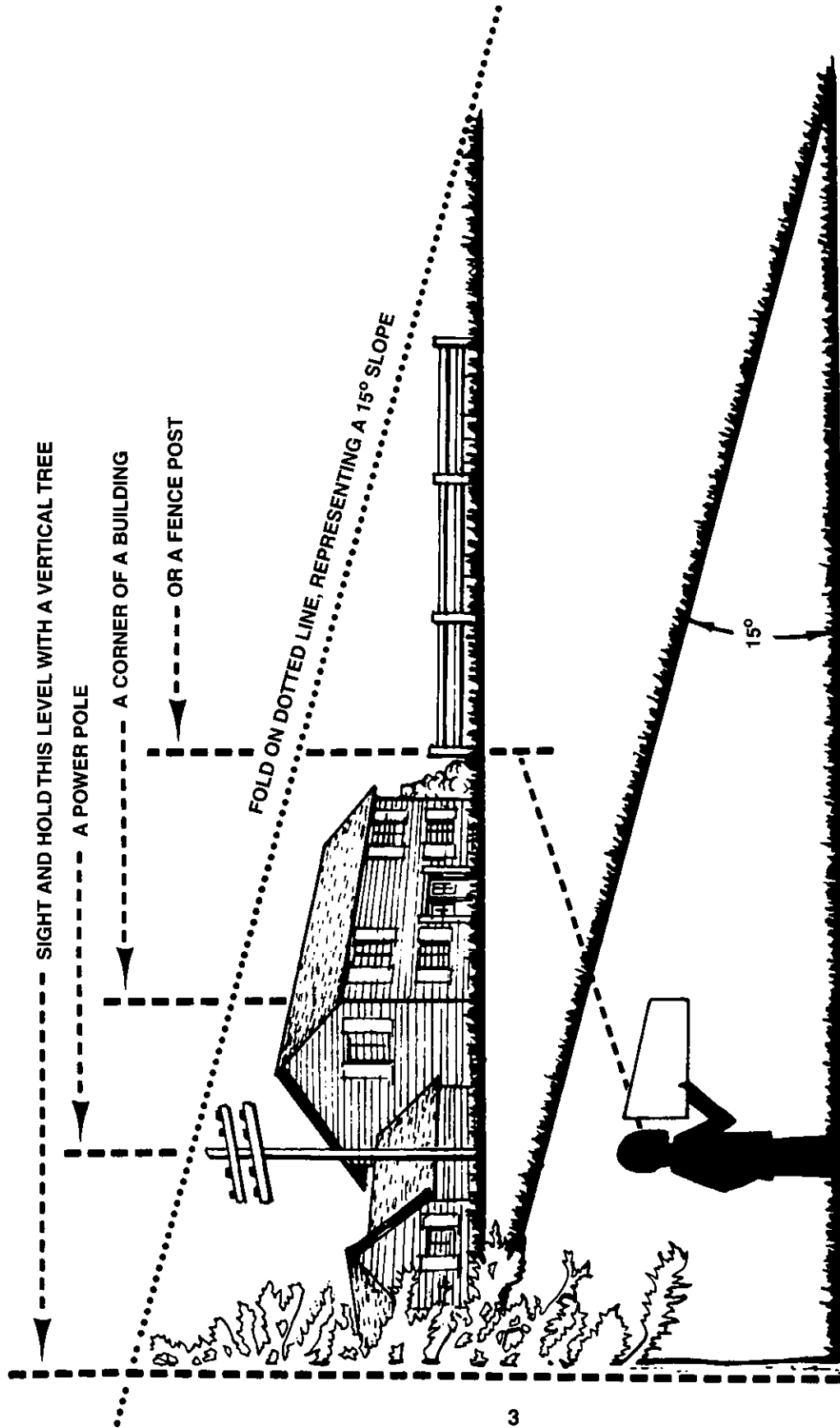

Do not mow on inclines with a slope in excess of 15 degrees (a rise of approximately 2-1/2 feet every 10 feet). A riding mower could overturn and cause serious injury. If operating a walk-behind mower on such a slope, it is extremely difficult to maintain your footing and you could slip, resulting in serious injury.

Operate RIDING mowers up and down slopes, never across the face of slopes.

Operate WALK-BEHIND mowers across the face of slopes, never up and down slopes.

# CONTENTS OF HARDWARE PACK

Remove this sheet from your owner's manual and lay the hardware on the illustration for identification purposes. After assembly, keep the Slope Gauge which is on the reverse side of this sheet for future use.

(Hardware pack may contain extra items which are not used on your unit.)

Part numbers are shown in parentheses.)

## A ATTACHING THE DECK LINKS



Eyebolts  
(711-0817)  
(Not Shown to  
Scale) Quantity — 3



Hex Nuts  
1/2-13 Thread  
(712-0206) Quantity — 3

## D ATTACHING THE DECK WHEELS (The wheels may already be attached to the cutting deck.)

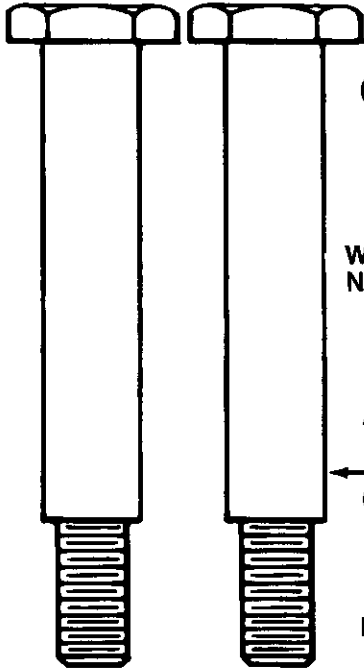

(46" Deck  
Only)

Deck  
Wheels are  
Not Shown

Front  
Axle Bolts  
3-1/4"  
Long  
(738-3056)

Flat Washers  
1/2" I.D.  
(736-0192)

Cupped  
Washers  
3/8" I.D.  
(736-0105)

Rear  
Axle Bolts  
2-1/4" Long  
(738-0533)

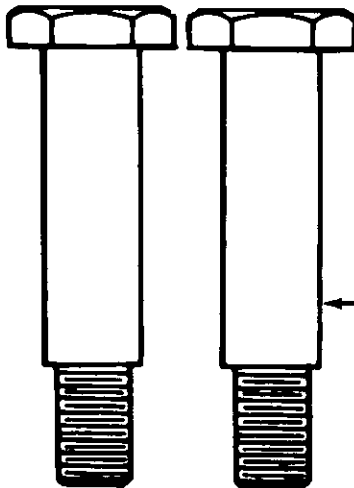

## C ATTACHING THE DECK

NOTE: This  
hardware may  
be assembled  
to the deck.

Flat  
Washers  
1/2" I.D.  
(736-0192)

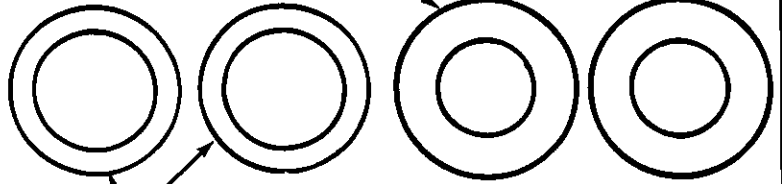

Spacers  
(750-0757 -  
46" Deck)  
(750-0932 -  
50" Deck)

Hairpin Clips  
(714-0101)

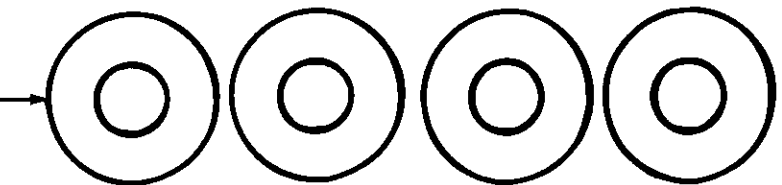
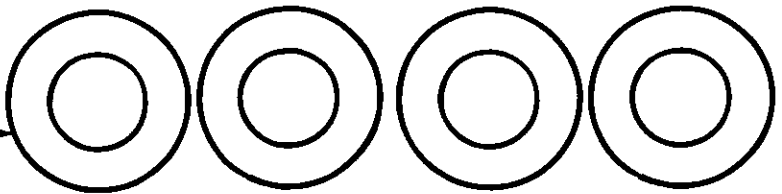
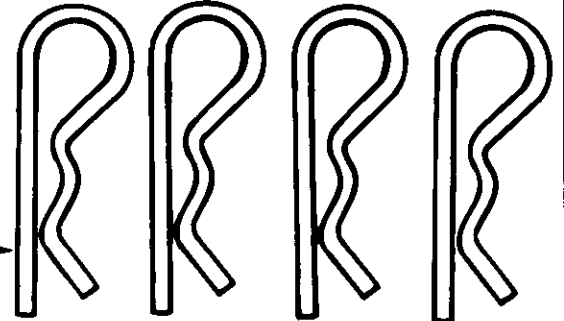

Hex Nuts  
3/8-16 Thread  
(712-0798)



INCHES

4

Cut Along This Line

4. Never carry children, even with the blades off. They may fall off and be seriously injured or interfere with the safe machine operation.
5. Never allow children under 14 years old to operate the machine. Children 14 years and over should only operate machine under close parental supervision and proper instruction.
6. Use extra care when approaching blind corners, shrubs, trees or other objects that may obscure your vision of a child or other hazard.
7. Remove key when machine is unattended to prevent unauthorized operation.

**IV. SERVICE**

1. Use extreme care in handling gasoline and other fuels. They are extremely flammable and the vapors are explosive.
  - a. Use only an approved container.
  - b. Never remove fuel cap or add fuel with the engine running. Allow engine to cool at least two minutes before refueling.
  - c. Replace fuel cap securely and wipe off any spilled fuel before starting the engine as it may cause a fire or explosion.
  - d. Extinguish all cigarettes, cigars, pipes and other sources of ignition.
  - e. Never refuel the machine indoors because fuel vapors will accumulate in the area.
  - f. Never store the fuel container or machine inside where there is an open flame or spark, such as a gas hot water heater, space heater or furnace.
2. Never run a machine inside a closed area.
3. To reduce fire hazard, keep the machine free of grass, leaves or other debris build-up. Clean up oil or fuel spillage. Allow machine to cool at least 5 minutes before storing.
4. Before cleaning, repairing or inspecting, make certain the blade and all moving parts have stopped. Disconnect the spark plug wire, and keep the wire away from the spark plug to prevent accidental starting.
5. Check the blade and engine mounting bolts at frequent intervals for proper tightness. Also, visually inspect blade for damage (e.g., excessive wear, bent, cracked). Replace with blade which meets original equipment specifications.

6. Keep all nuts, bolts and screws tight to be sure the equipment is in safe working condition.
7. Never tamper with safety devices. Check their proper operation regularly. Use all guards as instructed in this manual.
8. After striking a foreign object, stop the engine, remove the wire from the spark plug and thoroughly inspect the mower for any damage. Repair the damage before restarting and operating the mower.
9. Grass catcher components are subject to wear, damage and deterioration, which could expose moving parts or allow objects to be thrown. For your safety protection, frequently check components and replace with manufacturer's recommended parts when necessary.
10. Mower blades are sharp and can cut. Wrap the blade(s) or wear gloves and use extra caution when servicing blade(s).
11. Check brake operation frequently. Adjust and service as required.
12. Muffler, engine and belt guards become hot during operation and can cause a burn. Allow to cool down before touching.
13. Do not change the engine governor settings or overspeed the engine. Excessive engine speeds are dangerous.
14. Observe proper disposal laws and regulations. Improper disposal of fluids and materials can harm the environment and the ecology.
  - a. Prior to disposal, determine the proper method to dispose of waste from your local Environmental Protection Agency. Recycling centers are established to properly dispose of materials in an environmentally safe fashion.
  - b. Use proper containers when draining fluids. Do not use food or beverage containers that may mislead someone into drinking from them. Properly dispose of the containers immediately following the draining of fluids.
  - c. DO NOT pour oil or other fluids into the ground, down a drain or into a stream, pond, lake or other body of water. Observe Environmental Protection Agency regulations when disposing of oil, fuel, coolant, brake fluid, filters, batteries, tires and other harmful waste.

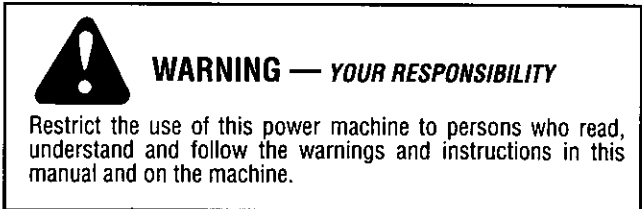

---

## UNPACKING

---

### TO REMOVE UNIT FROM CRATE

1. Remove all screws from the top of the crate using a 1/4" hex head socket or a flat blade screwdriver.
2. To remove ends, grasp top board on the end, and pull towards you in a downward motion.
3. Set panel aside to avoid tire punctures.
4. Repeat procedure for each side of the crate.
5. Remove and discard plastic bag which covers unit.
6. Loose parts (may include the owner's guide, steering wheel, battery fluid, chute deflector, etc.) are on the seat and wrapped in plastic. Carefully cut and remove the plastic wrap. Remove loose parts from the seat, or the seat and loose parts will be in a box on the tractor running board.
7. Remove the deck from beneath the tractor. Make certain brake and hydrostatic transmission are released. See the controls section of this manual for location of the parking brake release and the hydrostatic relief lever. Push unit off of the skid.
8. Remove page four from this manual and lay out the contents of the hardware pack according to the illustration for identification.

---

## ASSEMBLY INSTRUCTIONS

---

### BATTERY INFORMATION



- A. Battery acid must be handled with great care as contact with it can burn and blister the skin. It is also advisable to wear protective clothing (goggles, rubber gloves and apron) when working with it.\*
- B. Should battery acid accidentally splatter into the eyes or onto the face, rinse the affected area immediately with clean cold water. If there is any further discomfort, seek prompt medical attention.
- C. If acid spills on clothing, first dilute it with clean water, then neutralize with a solution of ammonia/water or baking soda/water.
- D. Since battery acid is corrosive, do not pour it into any sink or drain. Before discarding empty electrolyte containers, rinse them with a neutralizing solution.
- E. NEVER connect or disconnect charger clips to battery while charger is turned on as it can cause sparks.
- F. Keep all lighted materials (cigarettes, matches, lighters) away from the battery as the hydrogen gas generated during charging can be combustible.
- G. As a further precaution, only charge the battery in a well-ventilated area.

**\*Always shield eyes, protect skin and clothing when working near batteries.**



### DANGER

**Battery contains sulfuric acid.** Antidote: EXTERNAL—Flush with water. INTERNAL—Drink large quantities of water or milk. Follow with milk of magnesia, beaten eggs or vegetable oil. Call physician immediately. EYES: Flush with cool water for at least 15 minutes, then get prompt medical attention.

**Since batteries produce explosive gases, keep all lighted materials (cigarettes, lighters, matches, etc.) away.** Be sure to charge battery only in well-ventilated areas. Make certain venting path of battery (drain tube) is always open.

**KEEP BATTERIES  
OUT OF THE REACH OF CHILDREN!**

**IMPORTANT: After assembly, service engine with gasoline, and check oil level as instructed in the separate engine manual packed with your unit.**

**NOTE: Reference to right or left hand side of the unit is observed from the driver's seat, facing forward.**

### TOOLS REQUIRED FOR ASSEMBLY

- (1) 1/4" socket wrench or flat blade screwdriver
- (1) 1/2" wrench or socket wrench
- (1) 9/16" wrench or socket wrench
- (2) 7/16" wrenches or socket wrenches
- (1) Pair of pliers

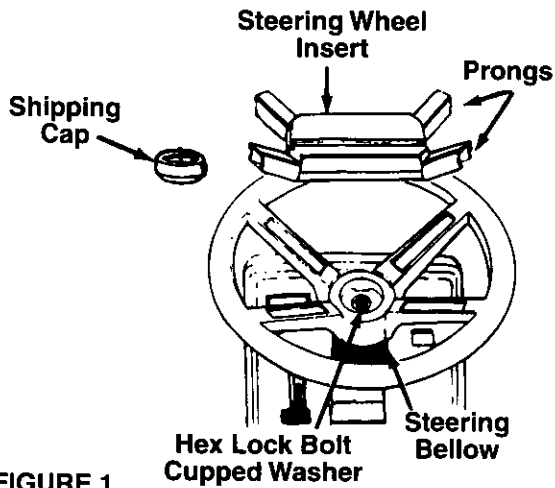

FIGURE 1.

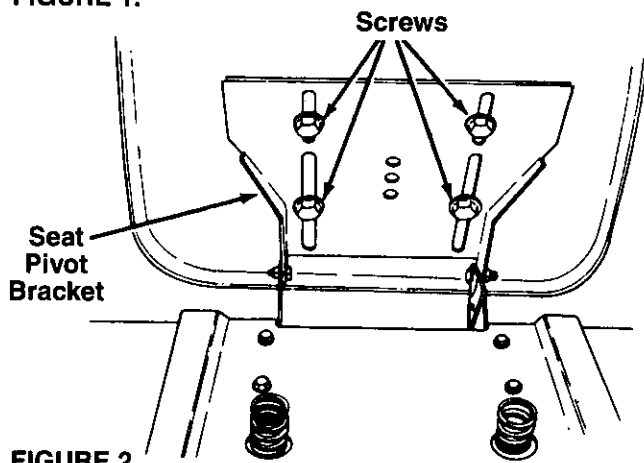

FIGURE 2.

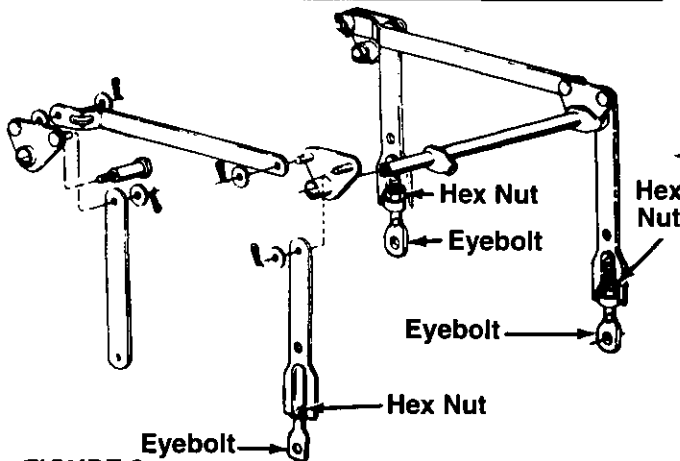
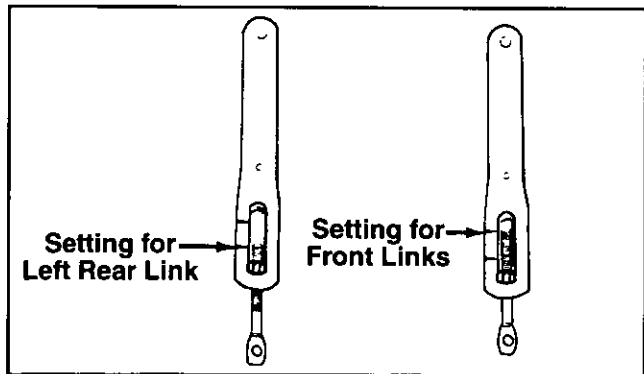

FIGURE 3.

## STEERING WHEEL INSTALLATION

1. The hardware for attaching the steering wheel has been packed inside the steering wheel. Carefully pry off the shipping cap and remove the hardware. Discard the shipping cap.
2. Remove the steering bellow from the lift lever on the right hand side of tractor. Place steering bellow over the steering shaft extending through the dash. See figure 1.

**NOTE:** If the openings on each end of the steering bellow are two different sizes, the smaller end goes down against the dash of the tractor.

3. With the wheels of the tractor pointing straight forward, place the steering wheel over the steering shaft, positioning steering wheel as desired.
4. Place the washer with the cupped side down over the steering shaft. Secure with hex lock bolt. See figure 1.
5. Snap the steering insert over the four spokes of the steering wheel.

## SEAT ASSEMBLY

Remove the four screws from the bottom of the seat. Place the seat in position against the seat pivot bracket, lining up the slotted holes in the pivot bracket with the holes in the seat. Select desired position for the seat, and secure with the four screws. See figure 2.

## ATTACHING THE DECK LINKS (Hardware A)

The three adjustable deck links have been shipped unassembled. Attach as follows.

1. Start 1/2" hex nuts on eyebolts provided. Insert the hex nuts and eyebolts into the adjustable lift links as shown in figure 3.
2. Thread eyebolts into the lift links and hex nuts. The left rear link should be adjusted so the eyebolt is to the **lower** mark as shown. The two front links should be adjusted to the **higher** mark.

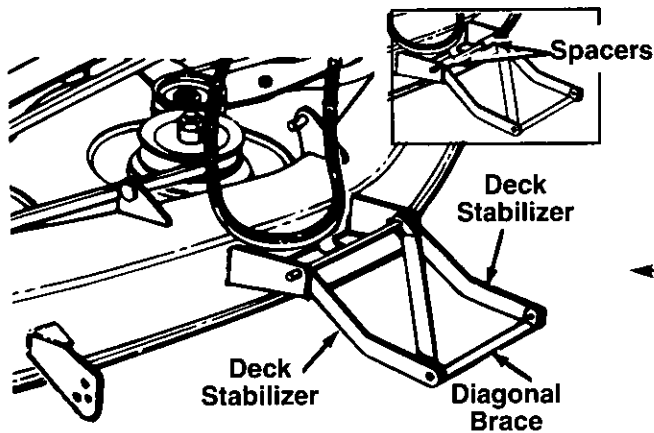

FIGURE 4.

### ATTACHING THE CUTTING DECK (Hardware C)

1. Move the tractor lift handle all the way back to the full raised position. Turn the tractor steering wheel all the way to the left.
2. The two deck stabilizers and the diagonal brace which are attached to the front of the deck are folded back over the deck for shipping purposes. Unfold them at this time. See figure 4.

**NOTE:** If the hardware for attaching the deck is assembled to your deck, remove the hairpin clips and flat washers from each deck bracket. Remove the spacers from the rod which is through the deck stabilizer by removing the hairpin clips and sliding out the rod. Replace the rod and hairpin clips. See figure 4, inset.

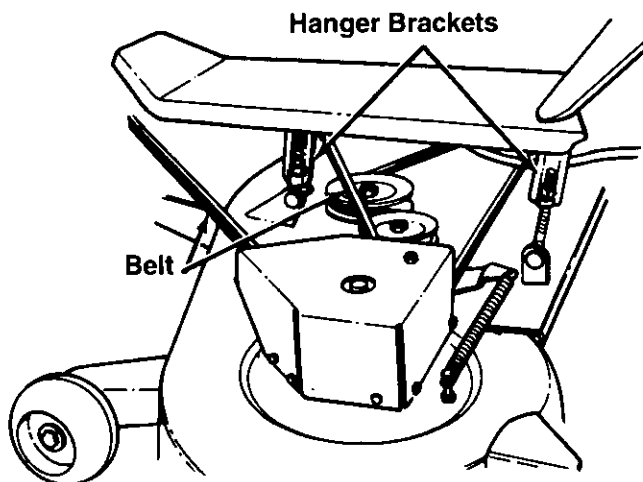

FIGURE 5.

3. Slide the deck under the tractor from the right side as you lift the stabilizers and diagonal brace over the right front wheel.
4. Move tractor lift handle forward to the lowest position.
5. Attach the four tractor hanger brackets to the deck as follows. The left front tractor hanger bracket goes through the center of the V-belt. See figure 5. Attach the rear hanger brackets first, then the front, using four flat washers and hairpin clips.
6. Disassemble the front cross bar from the tractor by removing two hairpin clips. Use the cross bar to attach the deck stabilizers, the diagonal brace and two spacers to the tractor frame.

**46" Deck:** Use the rear set of holes.

**50" Deck:** Use the forward set of holes.

Secure with the two hairpin clips just removed. See figure 6.

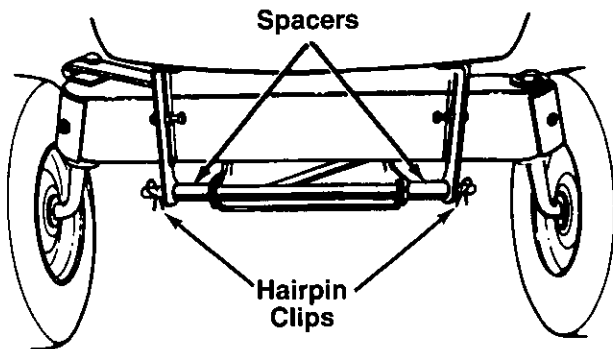

FIGURE 6.

7. Place the deck belt around the engine pulley and idler pulley.
8. Check all belt guards for clearance. The belt guards must be between 1/16" and 1/8" away from the belt when the PTO lever or switch is in the engaged or on position (be certain to disengage the PTO lever after checking).

### ATTACHING THE CHUTE DEFLECTOR



**WARNING:** Do not operate the tractor unless the chute deflector has been properly installed.

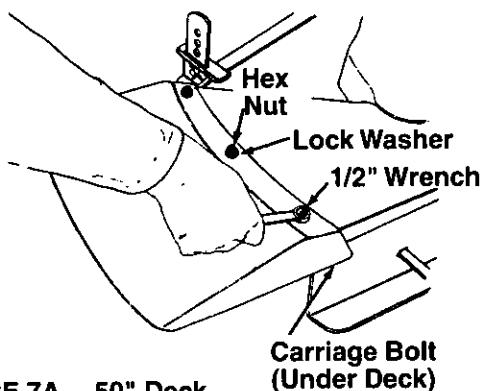

FIGURE 7A.—50" Deck

- Remove the bolts, nuts and cupped washers which are attached to the deck next to the chute opening. Place the chute deflector in position as shown in figure 7A or 7B. Secure with hardware just removed.



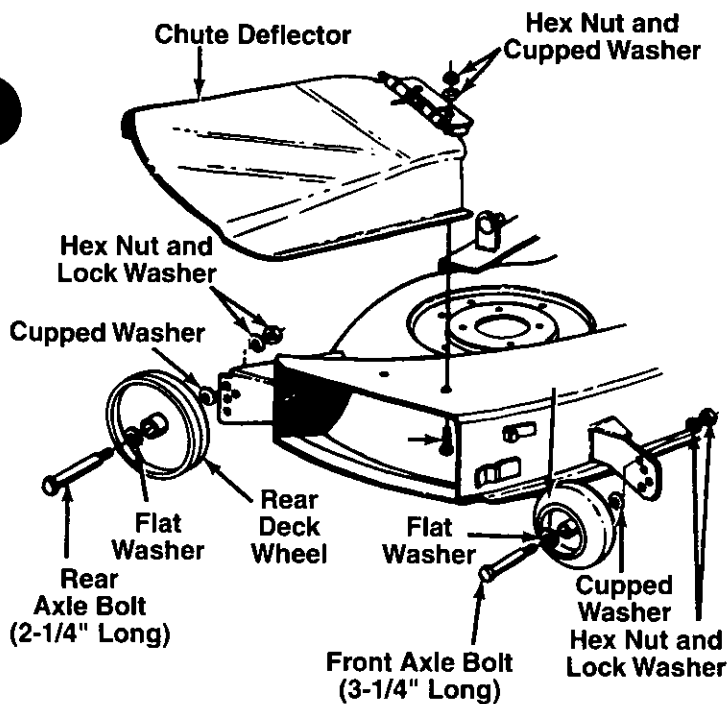

FIGURE 7B.—46" Deck

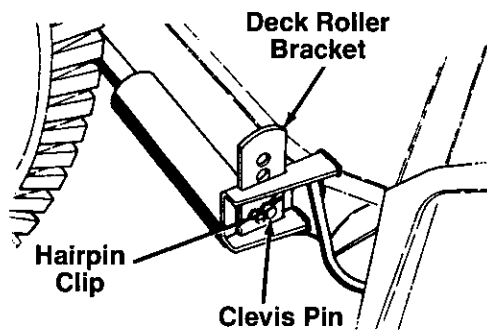

FIGURE 8.—50" Deck Only

## ATTACHING THE DECK WHEELS (Hardware D) (46" Deck Only)

If the deck wheels are not already attached, attach the wheels to the deck as follows. All wheels must be placed in the same relative position.

**Front Wheels:** Front axle bolts are the longer bolts. Front deck wheels have a rounded surface.

**Rear Wheels:** Rear axle bolts are the shorter bolts. Rear deck wheels are flatter.

Place flat washer 1/2" I.D. on axle bolt, then the deck wheel and cupped washer (crowned side of washer goes against the wheel). See figure 7B. Secure to deck with lock washer and hex nut. Tighten securely. Assemble remaining wheels in same manner.

## ATTACHING THE DECK ROLLER (50" Deck Only)

Remove the hairpin clips and clevis pins from each end of the deck roller. Insert the deck roller brackets up through the brackets provided on the rear of the deck. Attach with clevis pins and hairpin clips just removed, using the same hole location on each side of the deck. See figure 8.

## TIRE PRESSURE

The tires on your unit may be over-inflated for shipping purposes. Reduce the tire pressure before operating the unit. Check the side wall of the tires for proper inflation pressure.



**WARNING: Maximum tire pressure under any circumstances is 30 p.s.i. Equal tire pressure should be maintained on all tires.**

## LEVELING THE DECK

After attaching the deck to the tractor, check to be certain it is adjusted properly.

1. Check tire pressure in all four tires. See sidewall of tire for recommended inflation pressure.
2. Make certain all deck wheels or both ends of the deck roller are mounted in same relative hole locations.
3. Place the tractor on a level surface.
4. 46" Deck: Lower the deck until it reaches the ground. All four deck wheels should reach the ground at the same time.
5. Both Decks: Place the deck approximately 1" above the ground. Check to be certain the distance from the bottom edge of the deck to the ground is the same on both sides of the deck.

If adjustment is necessary, adjust the deck links on the left side of the deck as follows.

1. Make certain the PTO is disengaged. Remove the hairpin clip and washer from the weld bolt. Thread eyebolt up or down the link as necessary, and reassemble.

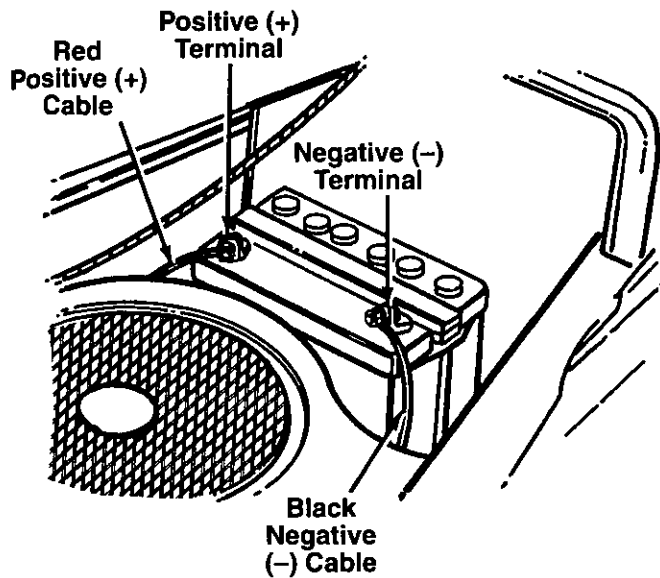

FIGURE 9.

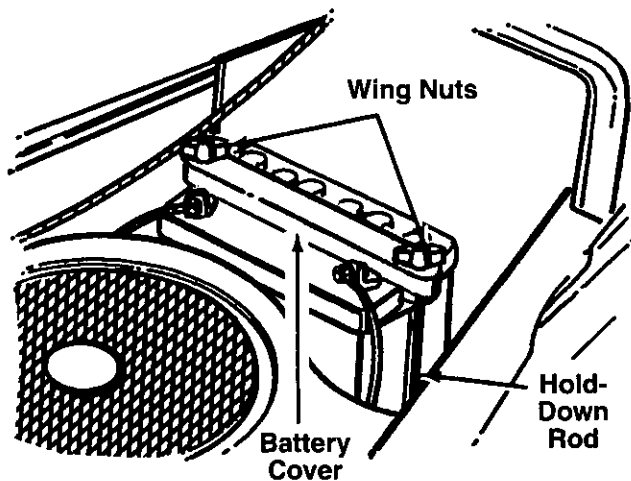

FIGURE 10.

2. Check to be certain the front of the deck is 1/4" to 3/8" lower than the rear of the deck. If it is not, adjust the two front links to obtain this distance.

### FINAL ASSEMBLY

1. Make certain all nuts and bolts are tightened securely.

### INSTALLING THE BATTERY

**NOTE:** If battery is put into service after date shown on top of battery, charge for minimum of 1 hour at 6-10 amps.

1. Lift the hood of the tractor. Remove the wing nuts from the hold-down rods which secure the battery cover to the battery. See figure 10.
2. Remove the plastic cover from the negative terminal.
3. Remove the hex bolt and nut from the negative (black) cable. Attach negative cable to the negative terminal with this bolt and nut.
4. Place battery cover over battery and secure with wing nuts removed in step 1.

**NOTE:** It may be necessary to pull up on the hold-down rods in order to start the wing nuts.

## CONTROLS

### IGNITION/LIGHT SWITCH

To start engine insert key into ignition switch and turn clockwise to the **START** position. Release key to the **ON** position once engine has fired. The lights are controlled by the ignition switch. After the tractor is running, turn the key counterclockwise to the **LIGHTS ON** position. See figure 11.



**WARNING:** To prevent accidental starting and/or battery discharge, remove the key from the ignition switch when the tractor is not in use.

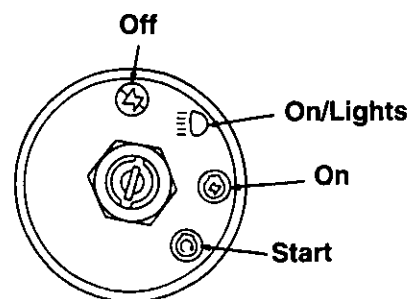

FIGURE 11.

## THROTTLE CONTROL

The throttle control is located on the left side of the dashboard and is used to regulate the engine speed. See figures 12 and 13. The engine should be operated from 3/4 to full throttle (FAST) when operating any equipment that uses the tractor engine as a source of power such as the mowing deck, snow thrower or rotary tiller.

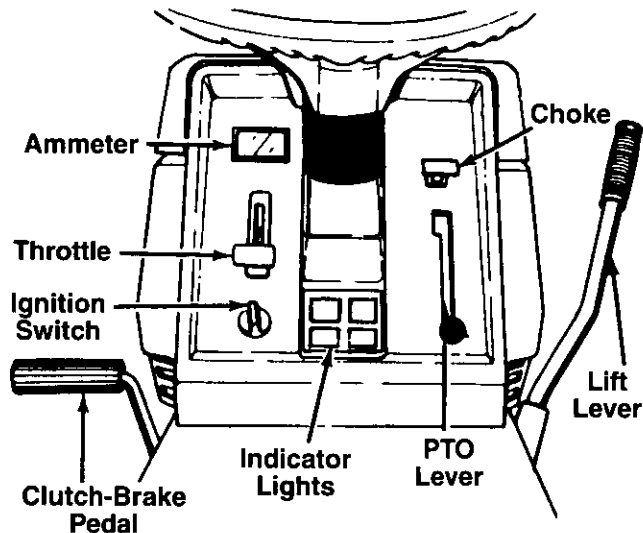

FIGURE 12.—Model 147W834H

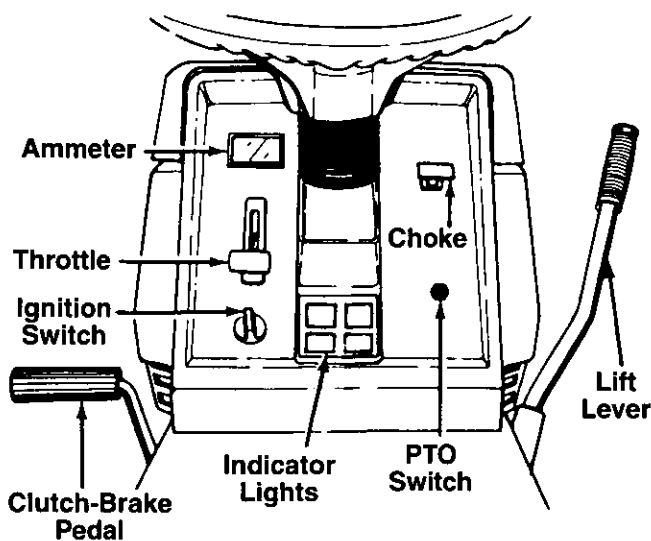

FIGURE 13.—Model 147Y834P

## CHOKE CONTROL

The choke control is located on the right side of the dashboard and is operated manually. Details for the choke operation are covered in the separate engine manual packed with your unit. See figures 12 and 13.

## AMMETER

The ammeter registers the rate of battery charge or discharge. The ammeter will register on the discharging side when starting the engine. It should register on the opposite side (charging) when the engine is running in the fast position until the battery is completely charged. With a fully charged battery or with the engine idling, the ammeter will not show a charge. See figures 12 and 13.

## HYDROSTATIC CONTROL LEVER

The hydrostatic control lever is located on top of the fender on the left side of the tractor. This single control lever, connected to the hydrostatic transmission, controls both the speed and direction of the tractor. Infinite speed control is achieved by moving the control lever forward or backward. The farther forward or backward you move the control lever, the faster you will travel. Pulling the control lever into neutral (N) area will stop the tractor. To increase rear wheel torque (pulling power), move the control lever towards neutral (N) position. The lawn tractor responds similar to shifting to a lower gear with a gear type transmission. See figure 14.

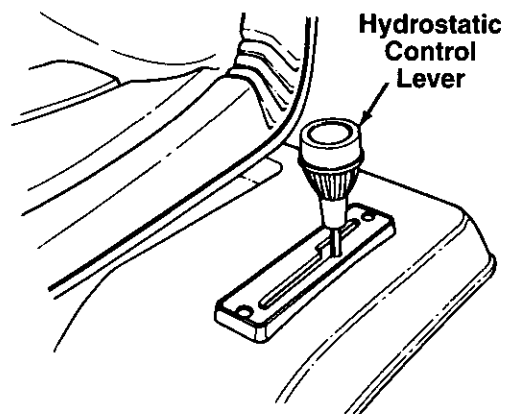

FIGURE 14.

## CLUTCH-BRAKE PEDAL

The clutch-brake pedal is located on the left side of the tractor. See figures 12 and 13. Depressing the pedal disengages the engine from the hydrostatic transmission and applies the brake.

**NOTE:** The clutch-brake pedal must be depressed to start the engine.

## PARKING BRAKE

To set the parking brake, depress the clutch-brake pedal and pull up the parking brake knob. It will stay in the raised position. To release the parking brake, depress and release the clutch-brake pedal. See figure 15.

**NOTE:** The parking brake must be set if the operator leaves the seat with the engine running.

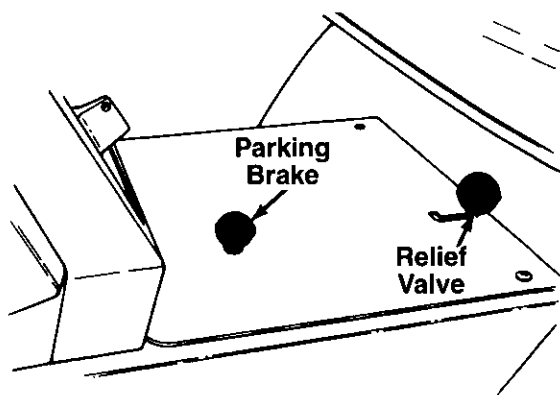

FIGURE 15.

### RELIEF VALVE

A hydrostatic relief valve is provided so the unit can be moved without the engine running. The lever which operates the relief valve is located on the console. See figure 15.

To operate the relief valve, place the hydrostatic control lever in neutral, release the parking brake, push the lever forward and to the right to lock. Be certain to release the lever by pushing it to the left before operating the engine.

### LIFT LEVER

The five position lift lever is used to change the operating position of the attachments. To operate, pull the lever towards you. To release, move the lever to the right and then forward. See figures 12 and 13.

### POWER TAKE-OFF (PTO) LEVER

(Model 147W834H)

The PTO lever is located on the right side of the dashboard. The PTO lever is used to engage and disengage the power to the attachments. To engage the PTO, lift the lever slowly and lock it into the notch. See figure 12.

**NOTE:** The PTO lever *must* be in the disengaged position (down) when starting the engine, when shifting into reverse and if the operator leaves the seat.

### POWER TAKE-OFF (PTO) SWITCH

(Model 147Y834P)

The power take-off control switch operates the front electric PTO clutch. Pull the switch knob to engage ("RUN"), or push the knob to disengage ("OFF") the PTO clutch. (See figures 13 and figure 16.)

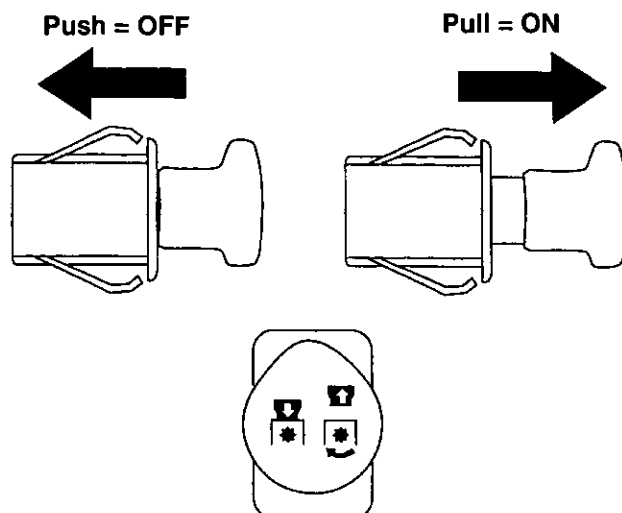

FIGURE 16.

### INDICATOR LIGHTS

Your tractor is equipped with three indicator lights, located on the dash panel. If a light illuminates when attempting to start the unit, proceed as follows:

CLUTCH—Depress the clutch pedal.

PTO—Disengage the PTO.

OIL—Check the crankcase oil level, and add oil as required.

## OPERATION



### WARNING

#### AVOID SERIOUS INJURY OR DEATH

- GO UP AND DOWN SLOPES, NOT ACROSS. • AVOID SUDDEN TURNS.
- DO NOT OPERATE THE UNIT WHERE IT COULD SLIP OR TIP.
- IF MACHINE STOPS GOING UPHILL, STOP BLADE(S) AND BACK DOWNHILL SLOWLY.
- DO NOT MOW WHEN CHILDREN OR OTHERS ARE AROUND.
- NEVER CARRY CHILDREN.
- LOOK DOWN AND BEHIND BEFORE AND WHILE BACKING.
- KEEP SAFETY DEVICES (GUARDS, SHIELDS, AND SWITCHES) IN PLACE AND WORKING.
- REMOVE OBJECTS THAT COULD BE THROWN BY THE BLADE(S).
- KNOW LOCATION AND FUNCTION OF ALL CONTROLS.
- BE SURE BLADE(S) AND ENGINE ARE STOPPED BEFORE PLACING HANDS OR FEET NEAR BLADE(S).
- BEFORE LEAVING OPERATOR'S POSITION, DISENGAGE BLADE(S), PLACE THE SHIFT LEVER IN NEUTRAL, ENGAGE BRAKE LOCK, SHUT ENGINE OFF AND REMOVE KEY.

READ OPERATOR'S MANUAL

### GAS AND OIL FILL-UP

Check oil level and add if necessary. Service the engine with gasoline as instructed in the separate engine manual packed with your tractor. Read instructions carefully.

**IMPORTANT:** Your tractor is shipped with oil; however, you must check the oil level before operating. Be careful not to overfill.

The gasoline tank is located under the seat. The filler neck is behind the seat. Do not overfill.



**WARNING:** Never fill fuel tank indoors, with engine running or while engine is hot.

## HYDROSTATIC TRANSMISSION FLUID AND FILTER

Change hydrostatic transmission fluid and filter initially after 10 to 20 hours of operation, and every 200 hours of operation or once a year thereafter.

## OPERATING THE TRACTOR

**IMPORTANT:** This unit is equipped with a **safety interlock system** for your protection. The purpose of the safety interlock system is to prevent the engine from cranking or starting unless the clutch-brake pedal is depressed and the PTO lever or switch is in the disengaged or OFF position. In addition, the PTO lever or switch must be in the disengaged or OFF position when the unit is put into reverse or the engine will shut off. If the operator leaves the seat with the PTO engaged or ON and/or without setting the parking brake, the engine will shut off.



**WARNING:** Do not operate the tractor if the interlock system is malfunctioning because it is a safety device, designed for protection.

1. **Model 147W834H:** Place the PTO lever in the disengaged (down) position.

**Model 147Y834P:** Place the PTO switch in the OFF position.

2. Depress the clutch-brake pedal and set the parking brake.
3. Place the hydrostatic control lever in the NEUTRAL (N) position.
4. Set the throttle control in the FAST position.
5. Pull out the choke control. (A warm engine requires less choking.)
6. Turn the ignition key to the right to the START position. After the engine starts, release the key. It will return to the ON position.
7. Slowly push in the choke as the engine warms up.
8. Depress the clutch-brake pedal so the parking brake is released and then release the clutch-brake pedal.
9. Move the hydrostatic control lever forward. The farther forward you move the hydrostatic control lever, the faster you will travel.

10. To stop the tractor, pull the hydrostatic control lever into NEUTRAL (N) or depress the clutch-brake pedal.

11. To shut off the engine, turn the ignition key to the left to the OFF position. Remove the key to prevent accidental starting while equipment is unattended.

Be sure that the lawn is clear of stones, sticks, wire, or other objects which could damage lawn tractor or engine. For best results and to insure more even grass distribution, do not mow when lawn is excessively wet.



**WARNING:** Before leaving the operator's position for any reason, disengage the blades, place the shift lever in neutral, engage the parking brake, shut engine off and remove the key.

When stopping the unit to empty a grass bag, etc., follow the instructions above. This procedure will also eliminate "browning" the grass, which is caused by hot exhaust gases from a running engine.

**IMPORTANT:** If you strike a foreign object, stop the engine. Remove wire from spark plug, thoroughly inspect the mower for any damage, and repair the damage before restarting and operating the mower.

**NOTE:** If any problems are encountered, refer to the *Trouble Shooting Guide*.

GRASS COLLECTOR Model 190-083 is available as optional equipment for tractors with 46" decks only.



**WARNING:** The mower should not be operated without the entire grass catcher or chute deflector in place.

**NOTE:** Under normal usage bag material is subject to wear, and should be checked periodically. Be sure to use only factory authorized replacement bag.

---

## ADJUSTMENTS

---



**WARNING:** Disconnect the spark plug wires and ground against the engine before performing any adjustments, repairs or maintenance.

### SEAT ADJUSTMENT

To adjust the position of the seat, loosen the four screws on the bottom of the seat. See figure 2. Slide the seat forward or backward as desired. Retighten the four screws.

## HYDROSTATIC NEUTRAL CONTROL ADJUSTMENT

The hydrostatic transmission control is in correct adjustment when the tractor does not move with the engine running, the clutch engaged and the hydrostatic control lever in the neutral position.

If adjustment is necessary, follow these steps:

1. Raise both rear wheels off the ground by placing blocks under the rear frame.
2. Remove the transmission panel by removing the parking brake knob and truss machine screws.
3. Loosen the hex jam nut on the speed selector adjusting rod. See figure 17.

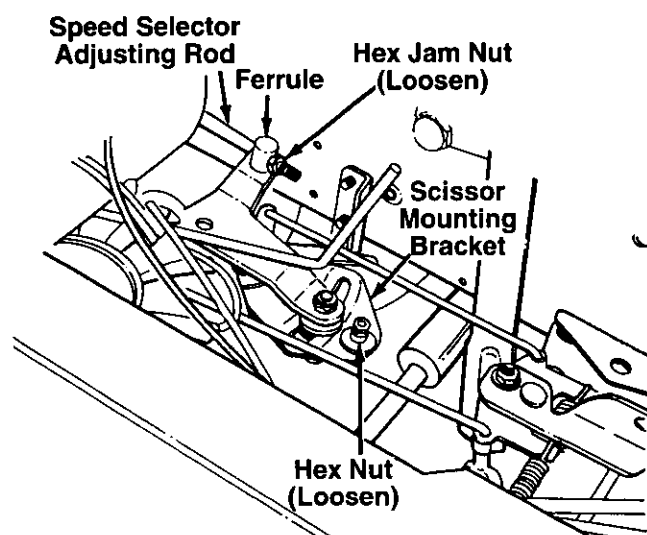

FIGURE 17.

4. Loosen the hex nut on the scissor mounting bracket. See figure 17.
5. Start the engine and run at full throttle.
6. Move the hydrostatic control lever until you find neutral (rear wheels do not rotate in either direction).



**WARNING:** Be careful of the cooling fan on the hydrostatic transmission.

7. Depress the clutch-brake pedal all the way and set the parking brake.
8. Shut off the engine.
9. Tighten the hex nut on the scissor mounting bracket.
10. Thread the speed selector rod in or out of the ferrule until the hydrostatic control lever lines up in the neutral position on the speed control index bracket.
11. Tighten hex jam nut against the ferrule.
12. Replace the transmission panel and parking brake knob.
13. Remove the blocks from under the frame and test the operation of the tractor.

## DECK LEVELING ADJUSTMENT

To correct for uneven cut, see deck leveling in the Assembly section.

## STEERING SHAFT ADJUSTMENT

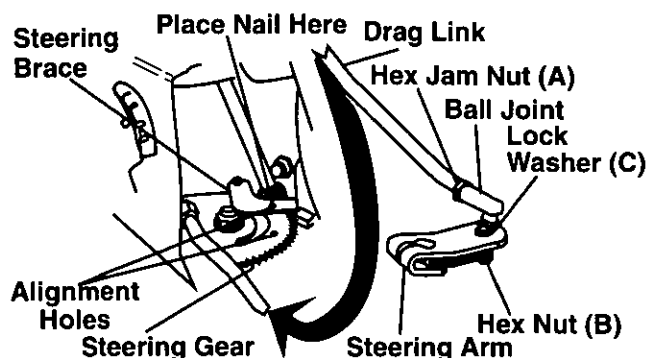

FIGURE 18.

If the tractor turns tighter in one direction compared to the other, the steering drag link must be adjusted. To adjust the drag link follow these steps. Refer to figure 18.

1. Loosen hex jam nut (A) at the rear of the ball joint.
2. Loosen and remove hex nut (B).
3. Lift the threaded portion of the ball joint out of the steering arm. Please do not misplace the hardware used to hold ball joint to steering arm. You will need it again.
4. Set the front wheels facing straight ahead.
5. Turn the steering wheel to the right or the left to match the alignment holes in the steering brace and the steering gear.
6. Once aligned, drop a nail through the steering brace and steering gear alignment holes.
7. Adjust the ball joint in or out on the drag link until the threaded portion of the ball joint slips through the hole in the steering arm. Make sure lock washer (C) is in position between the ball joint and the steering arm.
8. Tighten hex jam nut (A) against the ball joint.
9. Reattach the ball joint to the steering arm with hex nut (B). Finger tighten only at this time.
10. Turn the steering wheel fully to the left and the right to make sure that the drag link does not touch any part of the tractor frame. If the drag link does touch, start at step 1 and redo the adjustment.
11. Tighten hex nut (B).
12. Remove the nail used to align the steering gear.

## BRAKE ADJUSTMENT (See figure 19)

The brake is located by the right rear wheel inside the frame. During normal operation of this machine, the brakes are subject to wear and will require periodic examination and adjustment.



**WARNING:** Do not adjust the brake while the engine is running. Be sure to block the wheels of the tractor before making the brake adjustment.

To adjust the brake, remove the cotter pin. Adjust the castle nut so the brake starts to engage when the brake lever is 1/4" to 5/16" away from the axle housing.

**NOTE:** Figure 19 is shown with the unit tipped up on rear wheels for clarity only.

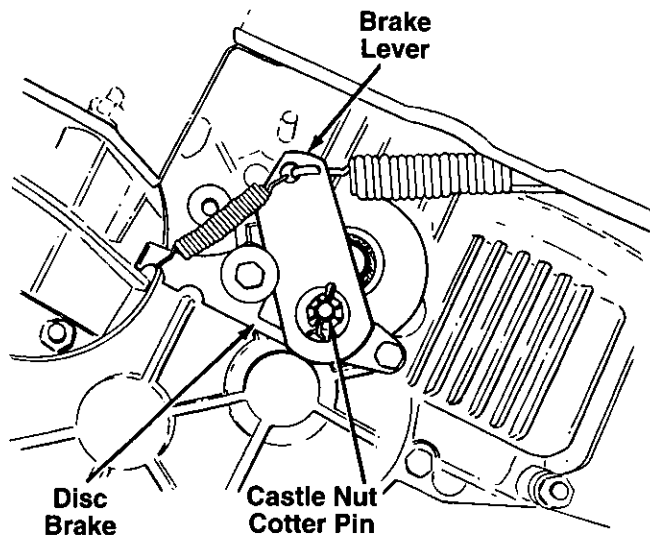

FIGURE 19.

## CARBURETOR ADJUSTMENTS



**WARNING:** If any adjustments are made to the engine while the engine is running (e.g. carburetor), disengage all clutches and blades. Keep clear of all moving parts. Be careful of heated surfaces and muffler.

Minor carburetor adjustments may be required to compensate for differences in fuel, temperature, altitude and load. Refer to separate engine manual for carburetor adjustment information.

**NOTE:** A dirty air cleaner will cause an engine to run rough. Be certain air cleaner is clean and attached to the carburetor before adjusting carburetor.

---

## LUBRICATION

---



**WARNING:** Always stop engine and disconnect spark plug wires before cleaning, lubricating or doing any kind of work on lawn tractor.

### STEERING GEARS

Lubricate teeth of steering gears with automotive multi-purpose grease after every 25 hours of operation or once a season. Refer to figure 18.

### STEERING SHAFT

Lubricate steering shaft at least once a season with light oil.

### HYDROSTATIC TRANSMISSION

The hydrostatic transmission is filled with approximately 60 ounces of API classification SH/CD 20W50 motor oil. Change the hydrostatic fluid and filter initially after 10 to 20 hours of operation, and every 200 hours of operation or once a year thereafter. Refer to Maintenance section.

### LINKAGE

Once a season lubricate all the pivot points on the clutch, brake and lift linkage with SAE 30 engine oil.

### FRONT WHEELS

The front wheels are provided with grease fittings. The rear wheels must be removed from the axle for lubrication. Lubricate at least once a season with automotive multi-purpose grease.

### PIVOT POINTS

Lubricate all pivot points with light oil at least once a season.

### BALL JOINTS

The ball joints and drag link ends are permanently lubricated.

---

## MAINTENANCE

---



**WARNING:** Disconnect the spark plug wire and ground against the engine before performing any adjustments, repairs or maintenance.

### TROUBLE SHOOTING

Refer to the trouble shooting section of this manual.

### HYDROSTATIC TRANSMISSION

The hydrostatic transmission is cooled by the oil, fan and fins. If the hydrostatic transmission runs hot, check to see if the fan is in operating condition and the fins are clean.

**NOTE:** DO NOT use high pressure water spray or steam to clean the hydrostatic transmission.

#### Hydrostatic Transmission Fluid and Filter

The hydrostatic transmission contains approximately 60 ounces of API classification SH/CD 20W50 motor oil. For operation in colder climates, 10W40 oil may be used. Also, a 15W50 synthetic engine oil would provide excellent all climate performance and extended time between oil changes. Use only filter part number HG-50037.

Change the hydrostatic transmission fluid and filter initially after 10 to 20 hours of operation, and every 200 hours of operation or once a year thereafter.

To change the hydrostatic transmission fluid and filter:

1. Remove oil filter on left side of transaxle and drain oil.
2. Clean around filter base and install new oil filter. Order part number HG-50037.
3. Raise rear of tractor and remove right rear wheel by removing hub cap, cotter pin and flat washer.
4. Level tractor by blocking rear axle.
5. Using a 1/4" allen wrench, remove the oil level plug from right side of transaxle. See figure 20.

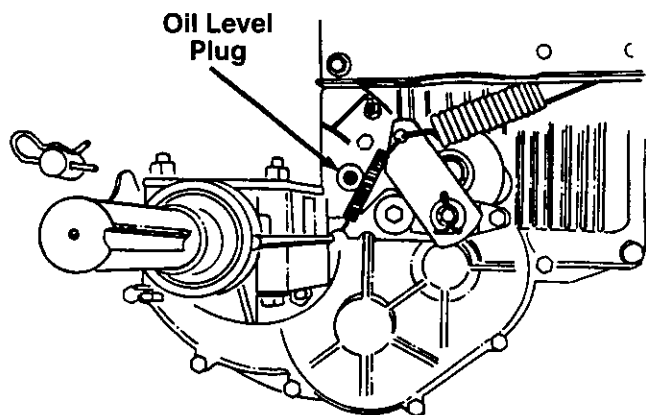

FIGURE 20.

6. Remove the transmission panel by removing the parking brake knob and truss machine screws.
7. Clean around filler hose (inside right frame) and bend hose upward. See figure 21.
8. Remove plastic vent from top of filler hose and insert a funnel. Fill transaxle with oil to the point of overflowing out of oil level hole.
9. Replace oil level plug and plastic vent.
10. Start tractor and run for 1 minute. Recheck oil level. Add oil if necessary.
11. Reassemble in reverse order.
12. Remove the blocks from under rear axle and test the operation of the tractor.

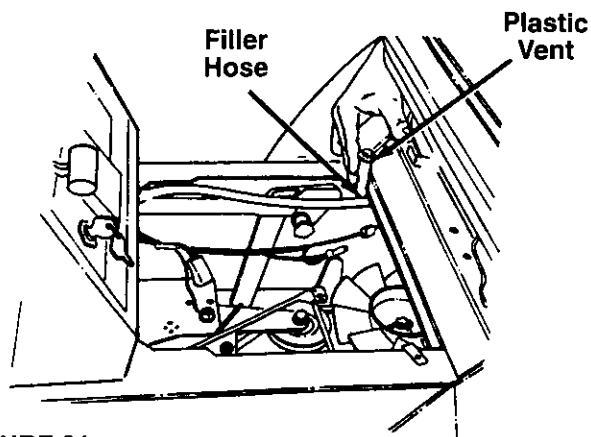

FIGURE 21.

### CUTTING BLADES



**WARNING:** Protect hands by using heavy gloves or a rag to grasp the cutting blades.

The blades may be removed for sharpening or replacement as follows:

#### 50" Decks only:

1. Remove the bolt and washer which holds the blade and adapter to the blade spindle. Remove the blade and adapter from the blade spindle.
2. Remove the two bolts, lock washers and nuts holding the blade to the adapter. See figure 22A.

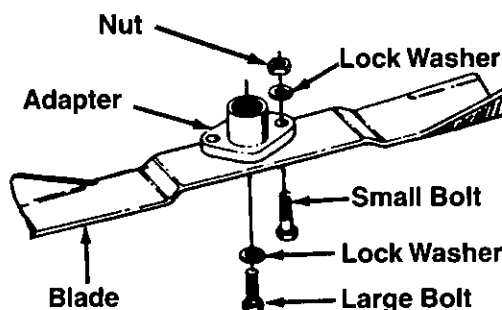

FIGURE 22A.—50" Deck

#### 46" Decks Only:

1. Remove the hex flange nut that holds the blade to the spindle.

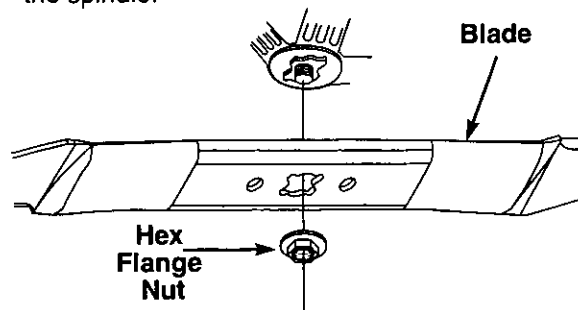

FIGURE 22B.—46" Deck



When sharpening the blades, follow the original angle of grind as a guide. It is **extremely important** that each cutting edge be ground equally to prevent an unbalanced blade. An unbalanced blade will cause excessive vibration when rotating at high speeds, may cause damage to the mower and could break, causing personal injury.

The blade can be tested for balance by balancing it on a round shaft screwdriver. Remove metal from the heavy side until it balances evenly.

When replacing the blade, be sure to install the blade with the side of the blade marked "Bottom" (or with part number) facing the ground when the mower is in the operating position.

### TORQUE SPECIFICATIONS

#### 46" Deck:

##### Blade

Hex Flange Nut: 70 ft.-lbs., 90 ft.-lbs.

##### Blade Spindle Screws

If disassembled for any reason, tighten the blade spindle screws between 200 and 275 inch pounds.

#### 50" Deck:

##### Blade

3/8" Dia. Bolt: 450 in. lb. min., 600 in. lb. max.

5/16" Dia. Bolt: 200 in. lb. min., 350 in. lb. max.

##### Blade Spindle Nuts

If disassembled for any reason, tighten the blade spindle nuts between 200 and 350 in. lbs.

To ensure safe operation of your unit, **all** nuts and bolts must be checked periodically for correct tightness.

## ENGINE

**Refer to the separate engine manual for all engine maintenance instructions.**

Service **air cleaner** every 10 hours under normal conditions. Clean every few hours under extremely dusty conditions. To service the air cleaner, refer to the separate engine manual packed with your unit.

The **spark plugs** should be cleaned and the gap reset once a season. Spark plug replacement is recommended at the start of each mowing season; check engine manual for correct plug type and gap specifications.

Maintain **engine oil** as instructed in the separate engine manual packed with your unit. **Read and follow instructions carefully.**

## FUEL FILTER

Your unit is equipped with a replaceable in-line fuel filter. Replace filter whenever contamination or discoloration is noticed. Order replacement filter through your authorized engine service dealer.

## CLEANING ENGINE AND DECK

Any fuel or oil spilled on the tractor should be wiped off promptly. Grass, leaves and other dirt must not be left to accumulate around the cooling fins of the engine or on any part of the machine.

Clean the underside of the deck after each mowing.

## WHEEL ADJUSTMENT

The caster (forward slant of the king pin) and the camber (tilt of the wheels out at the top) require no adjustment. Automotive steering principles have been used to determine the caster and camber on the tractor. The front wheels should toe-in 1/8 inch.

To adjust the toe-in, follow these steps.

1. Remove the hex nut and lock washer, and drop the end of the tie rod from the axle bracket. See figure 23.
2. Loosen the hex jam nut on tie rod.
3. Adjust the tie rod assembly for correct toe-in.

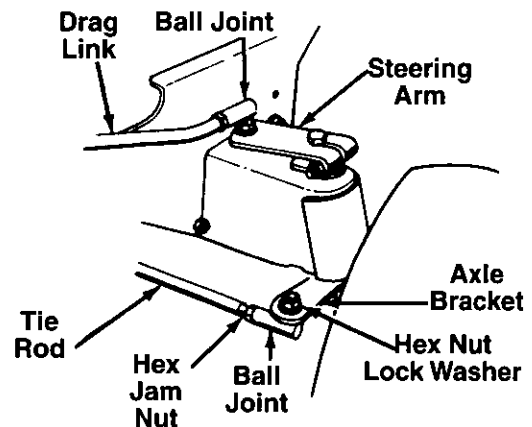

FIGURE 23.

Dimension "B" should be approximately 1/8" less than Dimension "A." See figure 24. To increase Dimension "B," screw tie rod into tie rod end. To decrease Dimension "B," unscrew tie rod from tie rod end. Reassemble tie rod. Check dimensions. Readjust if necessary.

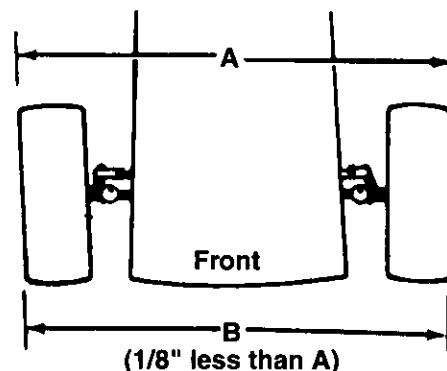

FIGURE 24.

## DRAG LINK

If the drag link or ball joints are changed, the new assembly must be adjusted to the exact same length as the original. If adjusted incorrectly, it will allow the tractor to turn sharper one direction than the other.

To take off the drag link, remove the nuts and lock washers holding the ball joint to the steering gear and right front axle bracket. See figure 23.

## BATTERY CARE AND MAINTENANCE

The battery is sealed and maintenance free.

### CHARGING THE BATTERY

The engine is equipped with an alternator which charges battery when tractor is operated. Under normal conditions, the battery only needs to be charged before, during and after off-season storage. Follow the instructions under "Off-Season Storage."

### REMOVE / INSTALLING / JUMP STARTING



**WARNING:** When removing or installing the battery, follow these instructions to prevent the screwdriver from shorting against the frame.

**Removing the Battery:** Disconnect negative cable first, then positive cable.

**Installing the Battery:** Connect positive cable first, then negative cable.

### Jump Starting

1. First, connect end of one jumper cable to the positive terminal of the good battery, then the other end to the positive terminal of the dead battery.
2. Connect the other jumper cable to the negative terminal of the good battery, then to the FRAME OF THE UNIT WITH THE DEAD BATTERY.



**WARNING:** Failure to use this procedure could cause sparking, and the gas in either battery could explode.

### CLEAN THE BATTERY

Clean the battery by removing it from the unit and washing with a baking soda and water solution. If necessary, scrape the battery terminals with a wire brush to remove deposits. Coat terminals and exposed wiring with grease or petroleum jelly to prevent corrosion.

### BATTERY FAILURES

Some common causes for battery failure are: incorrect initial activation, lack of water, adding chemicals other than water after initial activation, undercharging, overcharging, corroded connections, freezing. These failures do not constitute warranty.

## TIRES

Maximum tire pressure under any circumstances is 30 p.s.i. Equal tire pressure should be maintained on all tires. Check tire side walls for proper inflation.

When installing a tire to the rim, be certain rim is clean and free of rust. Lubricate both the tire and rim generously. Never inflate to over 30 p.s.i. to seat beads.



**WARNING:** Excessive pressure (over 30 p.s.i.) when seating beads may cause tire/rim assembly to burst with force sufficient to cause serious injury.

## BELT REPLACEMENT

### DECK BELTS (See figure 25)

1. Remove the deck from the tractor by following "Attaching the Deck" instructions in the Assembly section in reverse order. Refer to page 8.
2. Remove the left hand pulley cover by unhooking the spring and removing five self-tapping screws.
3. Remove the first drive belt.
4. Remove the right hand pulley cover by removing three self-tapping screws.
5. Pivot the spring-loaded idler, and lift belt off.
6. Remove the belt from around the three deck pulleys.
7. Reassemble new belts in reverse order.

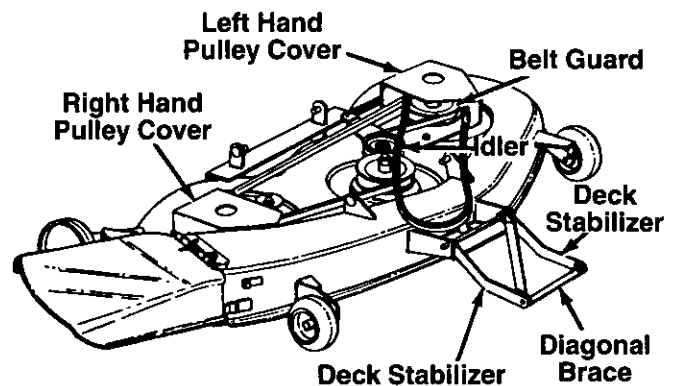

FIGURE 25.—46" Deck Shown

### DRIVE BELT (See figure 26)

1. Depress the clutch pedal and set parking brake.
2. Remove the deck from the tractor by following "Attaching the Deck" instructions in the Assembly section in reverse order.
3. Raise and block the front wheels of the tractor so you can work under it.
4. Remove the four self-tapping screws which hold the belt keeper assembly to the frame at the engine pulley. Push the belt keeper assembly forward, out of the way. See figure 26.

5. Loosen the hex bolt which acts as a belt keeper by the front idler pulley.
6. Loosen the rear idler pulley. Remove the belt from around both idler pulleys.
7. Unplug the electric PTO (if equipped).
8. Roll belt up off engine pulley, onto the pulley hub to obtain slack in the belt.
9. Remove belt from the transmission pulley, lifting the belt up over the fan on top of the pulley.
10. Remove belt from the engine pulley.

Reassemble using a new belt, following instructions in reverse order.

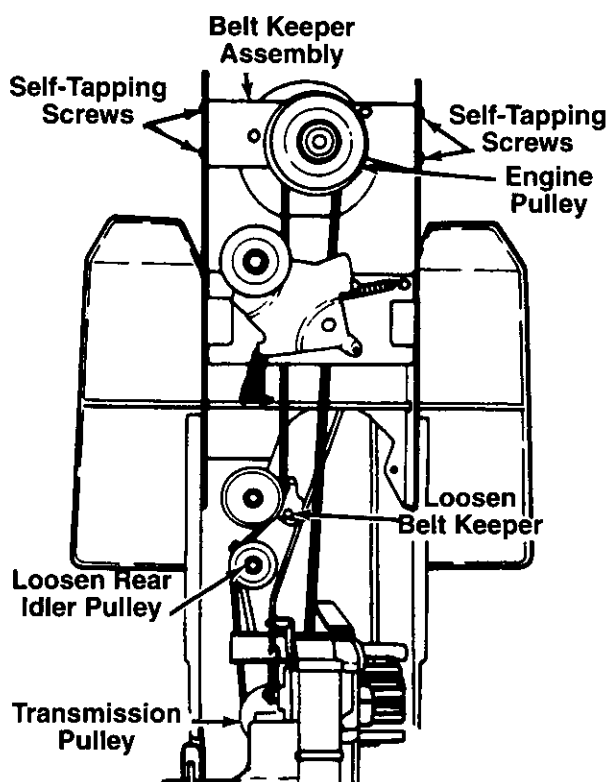

FIGURE 26.

## OFF-SEASON STORAGE

If the machine is to be inoperative for a period longer than 30 days, prepare for storage as follows.

1. Clean the engine and the entire unit thoroughly.
2. Lubricate all lubrication points. Wipe the entire machine with an oiled rag to protect the surfaces.
3. Refer to the engine manual for correct engine storage instructions. The engine must be completely drained of fuel to prevent gum deposits from forming on essential carburetor parts, fuel lines and fuel tanks.
4. **Charge battery fully.** The battery loses some of its charge each day when the unit is not used. NEVER store battery without a full charge. Recharge battery before returning to service or every two months, whichever occurs first.
5. When storing unit for extended periods, disconnect battery cables. Removing battery from unit is recommended.
6. Store unit in a clean, dry area. Do not store next to corrosive materials, such as fertilizer.

**NOTE:** When storing any type of power equipment in an unventilated or metal storage shed, care should be taken to rustproof the equipment. Using a light oil or silicone, coat the equipment, especially any chains, springs, bearings and cables.

## OPTIONAL EQUIPMENT

At the time of manufacture of tractor, the following optional equipment is available.

Description	Model No.
40" Single Stage Snow Thrower	OEM-190-832
45" Two Stage Snow Thrower	OEM-190-624
48" Dozer Blade	OEM-190-840
46" Deck Mulching Kit	OEM-190-118
Grass Collector for <u>46" Deck Only</u>	OEM-190-083
Tire Chains—23 x 9.5	OEM-190-964
100 lb. Wheel Weights	190-784-000
Sleeve Hitch Kit	OEM-190-929
Electric Lift Kit	OEM-190-749
Row Crop Cultivator	OEM-190-984
28" PTO Driven Rear Mounted Tiller	OEM-190-756
38" 8 HP Rear Mounted Tiller	OEM-190-766
Single Disc Harrow	OEM-190-980
10" Moldboard Plow	OEM-190-978
Gang Reel (Set of three)	45-0195*
38" Lawn Sweeper	45-0222*
Heavy Duty Lawn Roller	45-0179*
Heavy Duty Dump Cart	45-0171*
Tine De-Thatcher	45-0186*

\* Available through your local dealer or from Agri-Fab Inc., 303 W. Raymond Street, Sullivan, Illinois 61951.

# TROUBLE SHOOTING GUIDE

PROBLEM	POSSIBLE CAUSE(S)	CORRECTIVE ACTION
Engine will not crank	Safety switch button not depressed	There are two switches in the starting circuit of your unit: the clutch pedal switch and the deck lift lever switch. Make certain the actuator is fully depressing the buttons on each switch.
	Battery installed	The battery must be installed with negative terminal attached to black ground wire. Negative terminal is incorrectly identified at the post by "NEG", "N" or "-". The positive terminal, identified by "POS", "P" or "+", must be attached to the big red wire which goes to the solenoid.
	Battery is dead or weak	Charge with 6 amp charger until fully charged.
	Blown fuse or circuit breaker	Replace fuse with automotive type fuse. Fuses seldom fail without a reason. The problem must be corrected. Check for loose connections in the fuse holder. Replace fuse holder if necessary. A dead short may be in the cranking or charging circuit where the insulation may have rubbed through and exposed the bare wire. Replace the wire or repair with electrician's tape if the wire strands have not been damaged. Note: Look for a wire pinched between body panels, burned by the exhaust pipe or muffler or rubbed against a moving part.
Engine cranks but will not start	Throttle or choke not in starting position	Check owner's guide for correct position for throttle control and choke for starting.
	No spark to spark plug	Spark plug lead disconnected. Connect lead. Place spark plug lead away from engine block about 1/8". Crank engine. There should be a spark. If not, have engine repaired at authorized engine service dealer.  Faulty spark plug. To test, remove spark plug. Attach spark plug lead to spark plug. Ground the spark plug body against the engine block. Crank the engine. The spark plug should fire at the electrode. Replace if it does not.
	No fuel to the carburetor	Gasoline tank empty. Fill. Fuel line or in-line fuel filter plugged. Remove and clean fuel line. Replace filter if necessary.
	Air filter dirty	If the air cleaner is dirty, the engine may not start. Clean or replace as recommended by the engine manufacturer.
Engine smokes	Engine loses crankcase vacuum	Dipstick not seated or broken. Replace defective part. Engine breather defective. Replace.
Excessive vibration	Bent or damaged blade spindle	<b>Stop engine immediately.</b> Check all pulleys, blade adapters, keys, nuts and bolts for tightness and damage. Tighten or replace any damaged parts.
	Bent blade	<b>Stop engine immediately.</b> Replace damaged blade. Only use original equipment blades.
Mower will not discharge grass or leaves uncut strips	Engine speed low Speed selection Blades short or dull	Throttle must be set at full throttle. Use lower ground speed. The slower your ground speed, the better the quality of cut. Sharpen or replace blades (uncut strip problem only).

If the above steps fail to correct the problem, take the unit to your local authorized service dealer for repair.

# Models 147W834H and 147Y834P

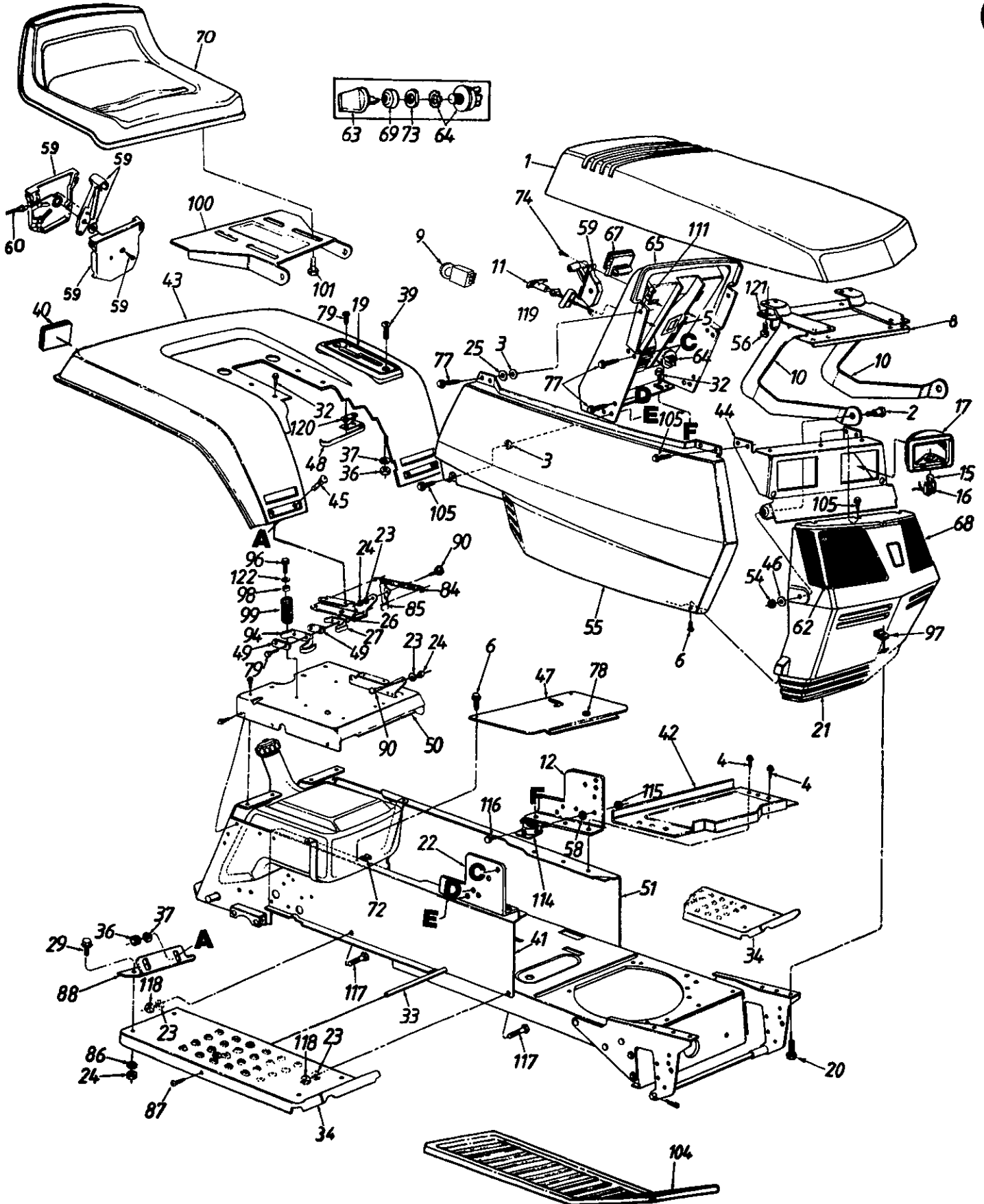

# Models 147W834H and 147Y834P

## PARTS LIST FOR GARDEN TRACTORS

REF. NO.	PART NO.	CODE	DESCRIPTION	REF. NO.	PART NO.	CODE	DESCRIPTION
1	731-1433		Hood Ass'y.	58	736-0222		Ext. L-Wash. 1/4" I.D.
2	738-0141		Shld. Bolt .437" Dia. x .35"	59	831-0823A		Throttle Control Box Ass'y.
3	726-0233		Bolt Retainer 1/4" I.D.	60	746-0630		Throttle Control Wire—39" Lg.
4	710-0776A		Hex AB-Tap Scr. 1/4 x .62" Lg.	62	731-0948		Lens—R.H.
5	783-0462		Switch Retainer (147Y834P)	63	725-1341B		Ignition Key
6	710-0351		Truss Mach. B-Tap Scr. #10 x .5" Lg.	64	725-1717	N	Ignition Switch
8	783-0121		Hood Reinforcement	65	731-0962		Dash Panel (147W834H)
9	725-1716	N	PTO Switch (147Y834P)		731-0963		Dash Panel (147Y834P)
10	783-0123		Hood Hinge	67	725-0925		Ammeter
11	746-0614A		Choke Control	68	731-0949		Lens—L.H.
12	17294B		Dash Support Brkt.—L.H.	69	725-1347		Ignition Switch Cap
15	725-0963		Lamp	70	757-0372		Seat Ass'y.
16	725-1650		Twist Lock—Lamp Socket	72	726-0139		Speed Nut #10Z
17	731-0705		Headlight Housing	73	725-1346		Ignition Switch Nut
19	731-1053A		Speed Control Index Brkt.	74	710-0779A		Truss Mach. AB-Tap Scr. #10 x .5" Lg.
20	710-0118		Hex Bolt 5/16-18 x .75" Lg.*	77	710-0642		Hex Wash. Hd. Tap Scr. 1/4 x .75" Lg.
21	731-1442A		Grille	78	731-0405		Snap Bushing
22	17293B		Dash Support Bracket—R.H.	79	710-0227		Hex Wash. Hd. AB-Tap Scr. #8 x .50" Lg.
23	736-0119		L-Wash. 5/16" I.D.*	84	732-0581B		Ext. Spring 5.31" Lg.
24	712-3010		Hex Nut 5/16-18 Thd. (Gr. 5)	85	17239A		Seat Lift Brkt.
25	736-0176		FI-Wash. 1/4" I.D. x .93" O.D.	86	736-0242		Bell-Wash. .345" I.D. x .88" O.D.
26	726-0278		Insulator Boss Plate	87	710-0323		Truss Machine Scr. 5/16-18 x .75" Lg.
27	725-1439		Seat Spring Switch	88	17406		Fender Bracket—R.H.
29	710-0376		Hex Bolt 5/16-18 x 1.0" Lg.*		17407		Fender Bracket—L.H.
32	710-0726		Hex Wash. Hd. AB-Tap Scr. 5/16 x .75" Lg.	90	738-0296		Shld. Bolt .437" Dia. x .268"
33	738-0435		Running Board Rod	92	738-0155		Shld. Bolt .437" Dia. x .162"
34	16922		Running Board—R.H.	94	725-1303		Spring Switch
	16921		Running Board—L.H.	96	710-0650		Hex Flange TT-Tap Scr. 5/16-18 x .875" Lg.
36	712-0287		Hex Nut 1/4-20 Thd.*	97	726-0211		U-Nut 5/16-18 Thd.
37	736-0329		L-Wash. 1/4" I.D.*	98	722-0160		Bushing
39	710-0166		Truss Mach. Scr. 1/4-20 x 1.0" Lg.	99	732-0588		Compression Spring
40	730-3000		Reflector	100	783-0039A	N	Seat Pivot Bracket
41	17360C	N	R.H. Side Frame	101	710-0870		Hex Tap Scr. 3/8-16 x .62"
42	783-0346A	N	Battery Plate	104	731-1052		Foot Pad
43	783-0351		Rear Fender	105	710-0599		Hex Tap Scr. 1/4-20 x .5" Lg.
44	17223		Light Bracket	111	712-0185		Speed Nut 1/4-20 Thd.
45	710-0167		Carriage Bolt 1/4-20 x .50" Lg.*	114	725-1426		Solenoid
46	736-0278		FI-Wash. .328" I.D. x .68" O.D.	115	712-0271		Hex Sems Nut 1/4-20 Thd.
47	17393B	N	Transmission Panel	116	710-0289		Hex Bolt 1/4-20 x .5" Lg.*
48	725-1643		Reverse Safety Switch	117	710-1012		Rib Neck Bolt 5/16-24 x .75" Lg.
49	726-0279		Insulator Plate	118	712-0123		Hex Nut 5/16-24 Thd.
50	683-0108A	N	Seat Plate	119	17782		Retainer Clip
51	17361C		L.H. Side Frame	120	726-0320		Insulator Nut Plate
54	712-0158		Hex Cent. L-Nut 5/16-18 Thd.	121	17762		Hood Reinforcement Spacer
55	731-1434		Side Panel Ass'y.	122	736-0159		FI-Wash. 5/16" I.D.
	731-1435		Side Panel Ass'y.—L.H.				
56	710-1005		Hex Wash. Hd. B-Tap Scr. 1/4 x .5" Lg.				

# Models 147W834H and 147Y834P

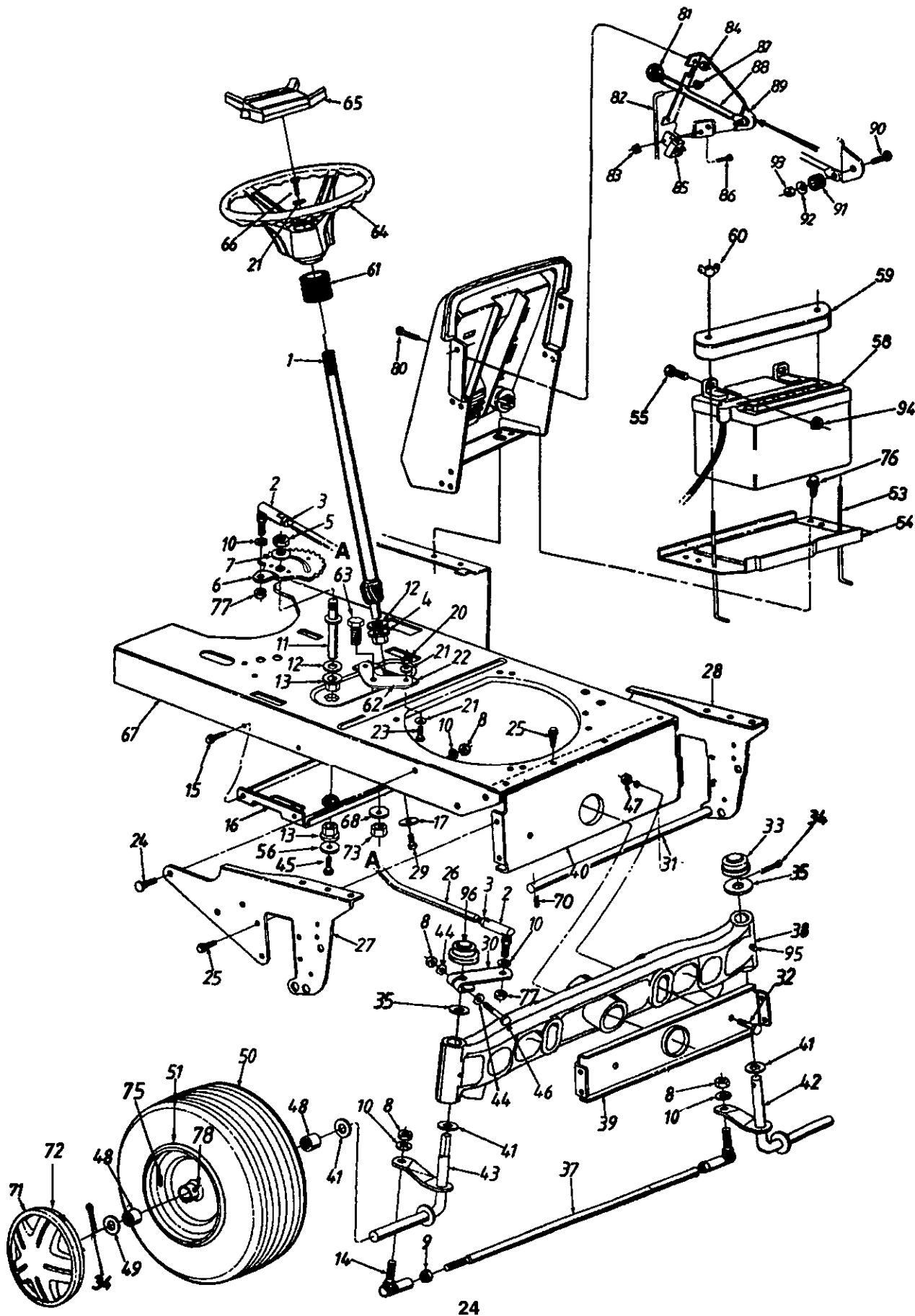



# Models 147W834H and 147Y834P

## PARTS LIST FOR GARDEN TRACTORS

REF. NO.	PART NO.	CODE	DESCRIPTION	REF. NO.	PART NO.	CODE	DESCRIPTION
1	738-0963	N	Steering Shaft Ass'y.	49	736-0316		FI-Wash. .71" I.D. x 1.5" O.D.
2	723-0448		Ball Joint 7/16-20 Thd.	50	634-0084		Wheel Ass'y. Comp.**
3	712-0240		Hex Jam Nut 7/16-20 Thd.		734-1727		Tire Only
4	741-0656		Hex Flange Brg.	51	634-0067		Rim Only
5	712-0318		Hex Jam Nut 5/8-18 Thd.	52	712-0291		Hex L-Nut 1/4-20 Thd.
6	717-0943C	N	Steering Gear Segment	53	711-0222A		Battery Hold Down Rod
7	736-0317		Bell-Wash. 5/8" I.D. x 1.25" O.D.	54	783-0346A	N	Battery Plate
8	712-0241		Hex Nut 3/8-24 Thd.	55	710-3015		Hex Bolt 1/4-20 x .75" Lg. (Gr. 5)
9	712-0711		Hex Jam Nut 3/8-24 Thd.	56	736-0343		FI-Wash. .33" I.D. x 1.25" O.D.
10	736-0169		L-Wash. 3/8" I.D.*	58	725-0453E	N	Battery
11	738-0768		Steering Gear Segment Shaft	59	731-1683		Battery Cover
12	736-0187		FI-Wash. .64" I.D. x 1.24" O.D.	60	712-3087		Wing Nut Plastic 1/4-20 Thd.
13	748-0227A		Hex Flange Brg. .63" I.D.	61	731-0954		Steering Bellow
14	723-3018		Ball Joint Ass'y.	62	783-0465	N	Steering Brace
15	710-0599		Hex Wash. Hd. TT-Tap Scr. 1/4-20 x .5" Lg.	63	738-0966	N	Shld. Bolt .5" Dia. x .925" Lg.
16	16888A		Deck Idler Support Brkt.	64	631-0027		Steering Wheel
17	748-0389		Cap 1.25" x .16"	65	731-0955		Steering Wheel Insert
19	736-0119		L-Wash. 5/16" I.D.*	66	710-0643		Hex L-Bolt 5/16-18 x 1" Lg.
20	712-0123		Hex Nut 5/16-24 Thd.*	67	17359C	N	Lower Frame
21	736-0242		Bell-Wash. .345" I.D. x .88" O.D.	68	736-0452		Bell-Wash. .396" I.D. x 1.14" O.D.
22	16894		Bearing Retainer Brkt.	70	714-0149B		Internal Cotter Pin
23	710-0157		Hex Bolt 5/16-24 x .75" Lg.	71	734-1788A	N	Hub Cap
24	710-0793		Ribbed Neck Bolt 3/8-24 x .8" Lg.	72	727-0425A		Spring Clip
25	710-0604		Hex Wash. TT-Tap Scr. 5/16-18 x .62" Lg.	73	712-3017		Hex Nut 3/8-16 Thd.
26	711-1106	N	Steering Drag Link	76	710-0896		Hex Wash. B-Tap Scr. 1/4 x .62" Lg.
27	783-0338		Pivot Bar Side Plate—R.H.	77	712-0262		Hex Jam L-Nut 3/8-24 Thd.
28	783-0337		Pivot Bar Side Plate—L.H.	78	737-0280		Grease Fitting
29	710-1309		Pan Hd. Scr. 5/16-18 x .63" Lg.	79	734-0255		Air Valve
30	983-0061A		Steering Arm Ass'y.	80	710-0286		Truss Mach. Scr. 1/4-20 x .5" Lg.†
31	738-0777A		Deck Connecting Rod	81	720-0232		Shift Knob†
32	738-0527		Shld. Bolt .498" Dia. x 2.45" Lg.	82	747-0708A		Deck Control Rod†
33	731-0484A		Cap	83	712-0272		Hex Sems Nut #10-24 Thd.†
34	714-0121		Cotter Pin 5/32" Dia.	84	712-0271		Hex Sems Nut 1/4-20 Thd.†
35	736-0316		Flat Washer	85	725-0465A		Safety Switch†
37	747-0753		Tie Rod	86	710-0473		Truss Mach. Scr. #10-24 x .5"†
38	719-0343		Pivot Bar Ass'y.	87	726-0106		Push Nut†
39	16889A		Pivot Bar Support Brkt.—Front	88	747-0513A		Blade Clutch Lever†
40	16890A		Pivot Bar Support Brkt.—Rear	89	783-0371		Deck Clutch Control Brkt.†
41	736-0188		FI-Wash. .76" I.D. x 1.49" O.D.	90	710-0106		Hex Bolt 1/4-20 x 1.25" Lg.*†
42	638-0007A		Front Axle Ass'y.—L.H.	91	735-0126		Rubber Washer†
43	638-0008A		Front Axle Ass'y.—R.H.	92	736-0173		FI-Wash. .281" I.D. x .73"†
44	736-0286		Bowed Washer	93	712-0324		Hex L-Nut 1/4-20 Thd.†
45	710-0538		Hex L-Scr. 5/16-18 x .62" Lg.	94	712-0271		Hex Sems Nut 1/4-20 Thd.
46	710-0331		Hex Bolt 3/8-24 x 2.25" Lg.	95	737-3000		Grease Fitting
47	712-0431		Hex L-Nut 3/8-16 Thd.*	96	726-0341		Cap
48	741-0516		Flange Brg. .75" I.D.				

† Model 147W834H Only.  
†† Model 147Y834P Only.

\* For faster service obtain standard nuts, bolts and washers locally.  
If these items cannot be obtained locally, order by part number and size as shown on parts list.

# Models 147W834H and 147Y834P

**IMPORTANT:** Use only Original Equipment Manufacturer (O.E.M.) V-belts when replacing belts. They are of special construction (type of cord, cord location, length, etc.). Use of V-belts other than O.E.M. belts generally will provide only temporary service. For best results, use only factory approved parts.

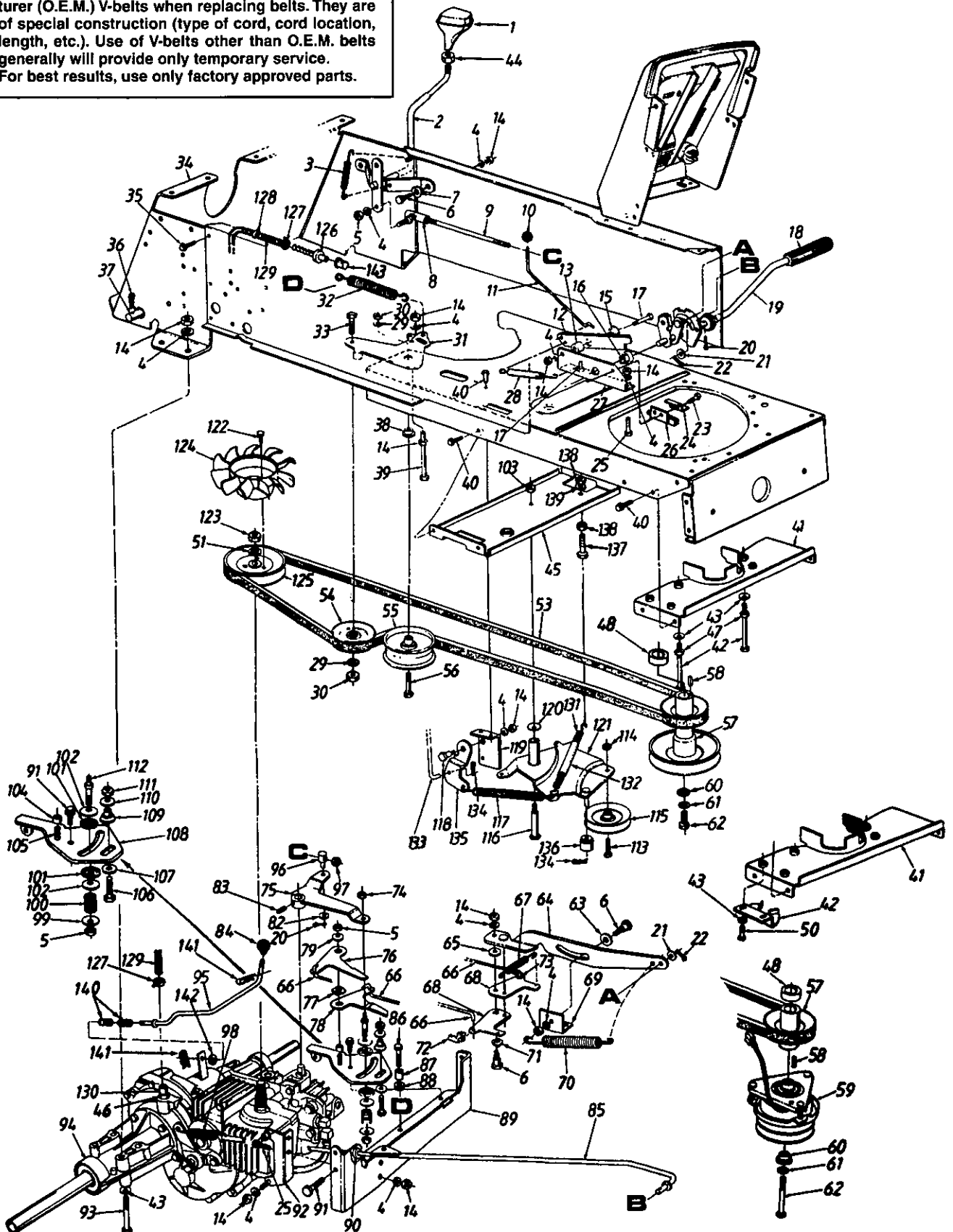

**PARTS LIST FOR GARDEN TRACTORS**

REF. NO.	PART NO.	CODE	DESCRIPTION	REF. NO.	PART NO.	CODE	DESCRIPTION
1	631-0009		Shift Knob	61	736-0171		L-Wash. 7/16" I.D.
2	647-0010		Speed Control Lever Ass'y.	62	710-0757		Hex Bolt 7/16-20 x 1.5" Lg.†
3	732-0433		Ext. Spring 2.75" Lg.		710-1049		Hex Bolt 7/16-20 x 3.75" Lg.††
4	736-0119		L-Wash. 5/16" I.D.*	63	736-0179		FI-Wash. .531" I.D. x 1.25" O.D.†
5	712-0123		Hex Nut 5/16-24 Thd.*	64	683-0030		Neutral Return Link Ass'y.
6	738-0296		Shld. Bolt .437" Dia. x .268"	65	736-3074		FI-Wash. .344" I.D. x 1.12" O.D. (Hdn.)
7	736-0141		Spr. Wash. .445" I.D. x .75" O.D.	66	747-0880		Connecting Rod
8	723-3012		Ball Joint 5/16-24 Thd.	67	732-0387		Ext. Spring 2.5" Lg.
9	747-0857		Speed Selector Adjusting Rod	68	17757		Balancer Brkt.
10	720-0166		Ball Knob	69	17755A		Bracket
11	747-0876		Brake Lockout Rod	70	732-0717		Ext. Spring 3.94" Lg.
12	16980A	N	Brake Lockout Brkt.	71	736-0141		Spr.-Wash. .445" I.D. x .75" O.D.
13	750-0214		Spacer .34" I.D. x .88" O.D.	72	726-0281		Rod End Clevis Clip—R.H.
14	712-3010		Hex Nut 5/16-18 Thd. (Gr. 5)	73	726-0280		Rod End Clevis Clip—L.H.
15	748-0234		Shld. Spacer .27" Lg.	74	712-0116		Hex Ins. L-Nut 3/8-24 Thd.
16	741-0225		Hex Flange Bearing	75	683-0032A		Pintle Bracket Ass'y.
17	710-0528		Hex Bolt 5/16-18 x 1.25" Lg.	76	783-0053		Flat Scissors
18	735-0196		Foot Pad	77	736-0174		Spr. Wash. .625" I.D. x .885" O.D.
19	17911		Foot Pedal Ass'y.	78	783-0054		Offset Scissors
20	714-0111		Cotter Pin 3/32" Dia. x 1" Lg.	79	736-3078		FI-Wash. .344" I.D. x 1" O.D. (Hdn.)
21	736-0275		FI-Wash. .34" I.D. x .68" O.D.	82	736-0185		FI-Wash. .406" I.D. x .75" O.D.
22	714-0115		Cotter Pin 1/8" Dia. x 1" Lg.	83	710-0257		Hex Socket Set Screw
23	710-0436		Hex B-Tap Scr. #10 x .62" Lg.	84	720-0187		Ball Knob
24	17962		Switch Plate	85	747-0859		Brake Rod
25	710-0118		Hex Bolt 5/16-18 x .75" Lg.	86	710-0778		Hex Wash. Hd. Scr. 1/4-20 x 1.5"
26	725-1657A		Safety Switch (Clutch)	87	750-0555		Spacer .39" Lg.
27	16924A		Clutch Ass'y. Mtg. Brkt.	88	712-3006		Hex Nut 1/4-20 Thd. (Gr. 5)
28	732-0395		Ext. Spring 2.51" Lg.	89	783-0051		Transaxle Torque Brkt.
29	736-0169		L-Wash. 3/8" I.D.*	90	731-0555A		Grommet
30	712-3017		Hex Nut 3/8-16 Thd. (Gr. 5)	91	710-0604		Hex TT-Tap Scr. 5/16-18 x .62"
31	783-0056		Idler Brkt.	92	783-0050		Transaxle Torque Brace
32	732-0470		Ext. Spring 4.75" Lg.	93	710-0189		Hex Bolt 5/16-18 x 3" Lg.
33	710-0344		Hex Bolt 3/8-16 x 1.5" Lg.	94	718-0241A		Transaxle (See Breakdown)
34	17344A		Hitch Plate	95	747-0909		Bypass Rod
35	710-0726		Hex AB-Tap Scr. 5/16 x .75" Lg.	96	711-0198		Ferrule 3/8-24 Thd.
36	714-0147		Hitch Pin	97	712-0711		Hex Jam Nut 3/8-24 Thd.
37	738-0482		Hitch Rod	98	732-0716		Ext. Spring 4.01" Lg.
38	738-0347		Shld. Spacer .625" I.D.	99	736-3008		FI-Wash. .312" I.D. x .75" O.D.
39	710-0176		Hex Bolt 5/16-18 x 2.75" Lg.	100	732-0718		Comp. Spring 1.19" Lg.
40	710-0599		Hex TT-Tap Scr. 1/4-20 x .5" Lg.	101	761-0196		Friction Washer
41	17358D		Belt Guard Brkt.	102	736-0219		Bell-Wash. .40" I.D. x 1.13" O.D.
42	710-0833		Hex Bolt 5/16-18 x 5.25" Lg.†	103	712-0375		Hex Cent. L-Nut 3/8-16 Thd.
	17418		Torque Bracket††	104	750-0808		Spacer
43	736-0242		Bell-Wash. .345" I.D. x .88" O.D.	105	710-1012		Rib Neck Bolt 5/16-18 x .62" Lg.
44	712-3008		Hex Jam Nut 3/8-16 Thd. (Gr. 5)	106	710-0299		Hex Bolt 1/4-28 x 1" Lg. (Gr. 5)
45	16888A		Deck Idler Support Brkt.	107	736-3090		FI-Wash. .26" I.D. x .72" O.D.
46	721-0330		O-Ring	108	783-0052		Scissors Mtg. Brkt.
47	712-3010		Hex Nut 5/16-18 Thd. (Gr. 5)†	109	750-0918		Centering Gauge Spacer
48	711-3301		Clutch Spacer	110	736-0270		Bell-Wash. 1/4" I.D.
50	710-3008		Hex Bolt 5/16-18 x .75" Lg. (Gr. 5)††	111	712-0138		Hex Nut 1/4-28 Thd.*
53	754-0435		"V"-Belt	112	738-0879		Friction Disc Stud
54	756-0116		Idler Pulley	113	710-0459		Hex Bolt 3/8-24 x 1.5" Lg.
55	756-0515		FI-Idler Pulley	114	712-0214		Hex Cent. L-Nut 3/8-24 Thd.
56	710-3096		Hex Bolt 3/8-16 x 2" Lg. (Gr. 8)	115	756-0293A		V-Belt Idler
57	756-0636		Engine Pulley†	116	738-0129		Shld. Bolt .498" Dia. x 2.05
	756-0637		Engine Pulley††	117	732-0478		Ext. Spring 6.12" Lg.
58	714-0118		Sq.-Key 1/4" x 1.5" Lg.†		732-0180		Ext. Spring 4" Lg.††
	714-0128		Sq.-Key 1/4" x 1" Lg.††	118	738-0155		Shld. Bolt .437" Dia. x .162"
59	717-1434		Electric Clutch††		710-0158		Hex Bolt 5/16-24 x 1.75" Lg.††
60	732-0322		FI-Wash. .44" I.D. x 1.25"†	119	13833		Parking Brake Mtg. Brkt.
	738-0785		Shld. Spacer††				

**PARTS LIST FOR GARDEN TRACTORS (CONTINUED)**

REF. NO.	PART NO.	CODE	DESCRIPTION	REF. NO.	PART NO.	CODE	DESCRIPTION
120	736-0105		Bell-Wash. .38" I.D. x .88" O.D.	132	731-0757		Convolved Conduit†
121	14076A		Idler Brkt. Deck Ass'y.	133	747-0708A		Deck Control Rod†
122	710-3007		Hex Tap Scr. #12 x 3/8" Lg.	134	714-0104		Internal Cotter Pin†
123	712-3035		Hex Jam Nut 9/16-18 Thd.	135	13887		Deck Control Pivot Brkt.†
124	731-1449		Fan	136	748-0278		Spacer†
125	756-0635A		Input Pulley	137	710-0501		Hex Bolt 1/4-20 x 2" Lg.*
126	731-1480		Plastic Vent	138	712-0287		Hex Nut 1/4-20 Thd.*
127	726-0324		Hose Clamp	139	736-0329		L-Wash. 1/4" I.D.*
128	725-0157		Cable Tie	140	732-0145		Comp. Spring 1" Lg.
129	751-0588		Hose 1/2" I.D. x 18" Lg.	141	714-0104		Hairpin Clip
130	731-1485		Hose Fitting	142	736-0463		FI-Wash. 1/4" I.D.
131	732-0308		Ext. Spring 6.37" Lg.†	143	731-1481		Plastic Vent Cap

†Model 147W834P Only.

††Model 147Y834P Only.

## Models 147W834H and 147Y834P

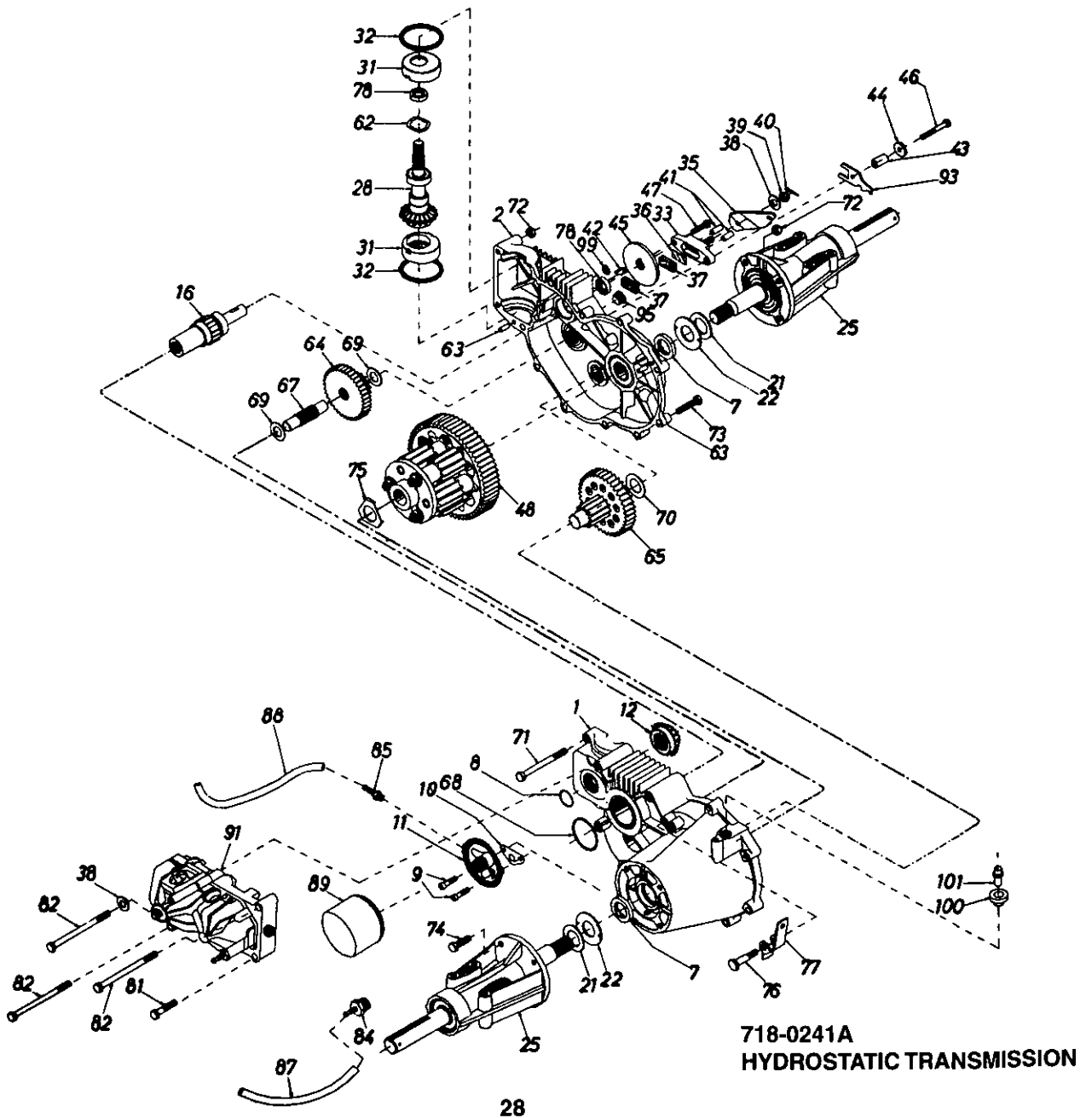

# Models 147W834H and 147Y834P

## PARTS LIST FOR 718-0241A HYDROSTATIC TRANSMISSION

REF. NO.	PART NO.	DESCRIPTION	QTY.
1	HG-52881	Housing-L.H. Ass'y.	1
2	HG-52879	Housing-R.H. Ass'y.	1
7	HG-44782	Oil Seal .984" x 1.5" x .25"	2
8	HG-50070	Quad Ring	1
10	HG-44920	Filter Base Gasket	1
11	HG-70053	Filter Base Ass'y.	1
12	HG-62876	Pinion Ass'y.	1
16	HG-62877	Brake Shaft Ass'y.	1
21	HG-44805	Washer, 1.0" x 1.63" x .08"	2
22	HG-44806	Washer, 1.0" x 2.06" x .09"	2
25	HG-82888	Axle Mounting Horn Ass'y.	2
28	HG-70054	Input Ass'y.	1
31	HG-44800	Ret. Bearing	2
32	HG-44802	O-Ring 2-1/2" O.D.	2
33	HG-62589	(Sub) Brake Yoke Ass'y.	1
35	HG-44094	Brake Arm	1
36	HG-44134	Puck Plate	1
37	HG-44132	Brake Puck	2
38	HG-44130	Washer, 7/16" x 7/8" O.D. x .060 H.T.	2
39	HG-44142	Nut, Castle 5/16-24 PL	1
40	HG-44101	Cotter Pin	1
41	HG-44127	Brake Actuating Pin	2
42	HG-44143	Hi-Pro Key 3/16" x 5/8"	1
43	HG-23711	Torsion Spring Spacer	1
44	HG-44278	Washer 7/8 O.D. x .260 I.D. x 1/8	1
45	HG-44090	Disc Brake	1
46	HG-44300	Bolt 1/4-20" x 2 W/Nylok Gr. 5	1
47	HG-44433	Bolt 1/4-20" x 1 W/Nylok Gr. 5	1
48	HG-62834	Differential Ass'y.	1
62	HG-44843	Wave Washer	1
63	HG-44757	Dowel Pin	2
64	HG-44776	Reduction Gear 14T-38T	1
65	HG-70051	Final Drive Pinion Ass'y.	1
67	HG-44779	Jack Shaft	1
68	HG-44781	O-Ring	1
69	HG-44795	FI-Wash. 5/8" I.D. x 1-5/32" O.D. Ht.	2
70	HG-44794	FI-Wash. 7/8" I.D. x 1-1/2" O.D. Ht.	1
71	HG-44827	Hex Bolt H.D. 5/16-18" x 3-1/2"	2
72	HG-43064	Hex Lock Nut 5/16-18" 2-Way Plt.	4
73	HG-44841	Hex Bolt 5/16-18" x 1-1/2" Gr. 5 Plt.	11
74	HG-45089	Hex Bolt 5/16-18" x 1	7
75	HG-44880	Differential Washer .050	1
76	HG-44785	Shld. Bolt	1
77	HG-44786	Freewheel Actuating Arm	1
78	HG-44761	Oil Seal .625" x 1.0" x .25"	2
81	HG-43084	Hex Bolt 5/16-18" x 1-3/4"	1
82	HG-44820	Hex Bolt 5/16-18" x 4-1/2"	3
84	HG-50009	SAE Port Straight Fitting 7/8"	1
85	HG-50010	SAE Port Straight Fitting 7/16"	1
87	HG-50011	Hose, 8-1/2" Long	1
88	HG-50012	Hose 10-1/2" Long	1
89	HG-50037	Spin-On Filter	1
91	HG-BDU-10L-256	Transmission	1
93	17434A	Bracket	1
95	HG-9005110-5600	Straight Thread Plug	1
99	HG-50136	Washer 5/16" I.D. x 9/16" O.D.	1
100	HG-50133	Vent Bushing	1
101	HG-50134	Vent	1
102	HG-70052	Seal Kit	1

# Models 147W834H and 147Y834P

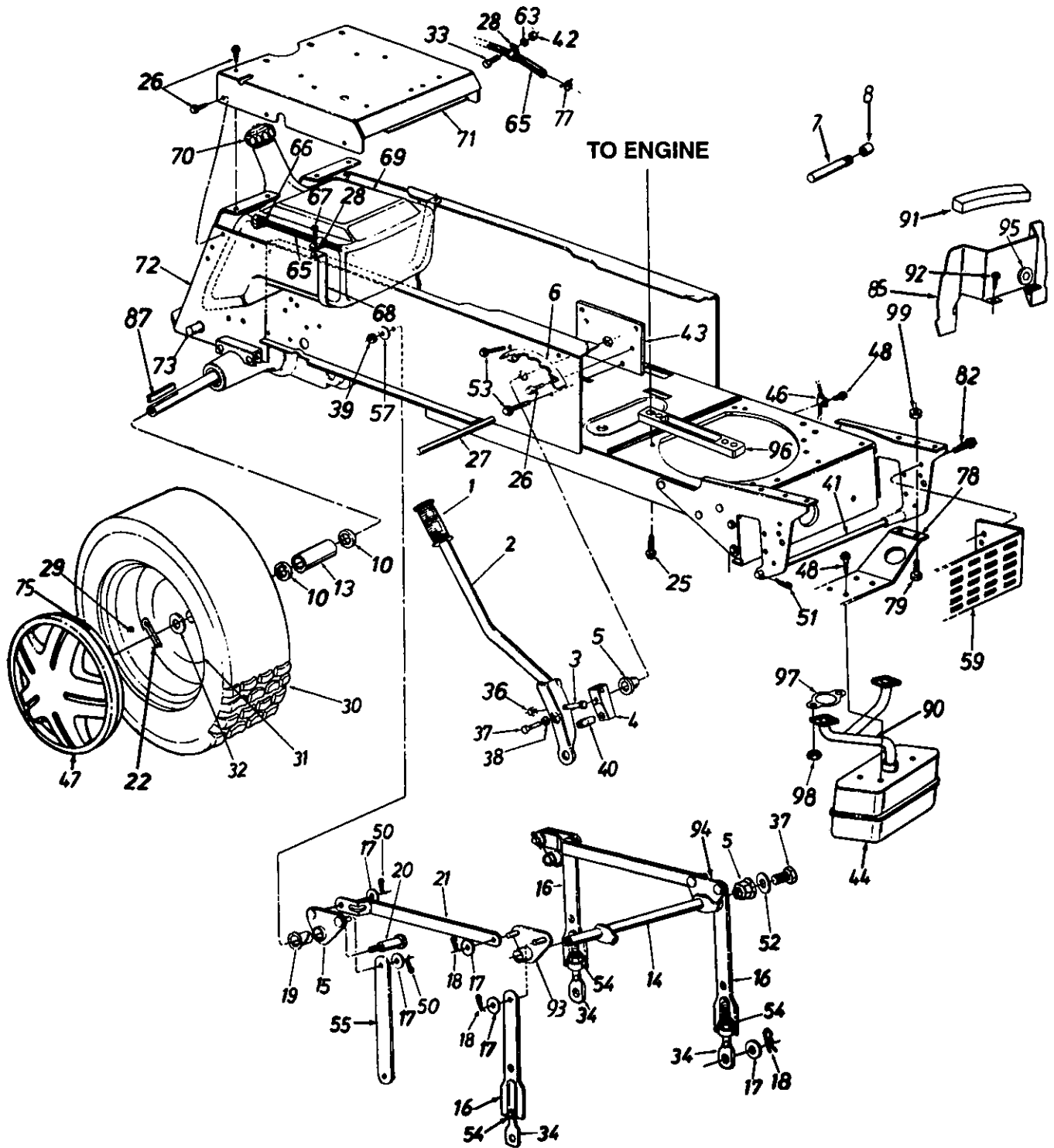

# Models 147W834H and 147Y834P

## PARTS LIST FOR GARDEN TRACTORS

REF. NO.	PART NO.	CODE	DESCRIPTION	REF. NO.	PART NO.	CODE	DESCRIPTION
1	720-0233		Grip	44	751-0617		Muffler
2	97282		Lift Handle Ass'y.	46	726-0273		Mounting Clamp
3	710-0442		Hex Bolt 5/16-18 x 1.5" Lg.*	47	734-1789A	N	Hub Cap
4	748-0274A		Lift Shaft Drive	48	710-0599		Hex TT-Tap Scr. 1/4-20 x .5" Lg.
5	741-0225		Plastic Hex Brg. 5/8" I.D.	50	714-0111		Cotter Pin .09 Dia. x 1.0" Lg.
6	14231		Index Brkt. Deck Lift	51	714-0149B		Int. Cotter Pin
7	737-0286		Oil Drain Pipe	52	736-0231		Flat Wash. .34" I.D. x 1.12" O.D. x .125"
8	751-0572		Oil Drain Plug				
10	736-0163		FI-Wash. 1.03" I.D. x 1.62" O.D.	53	710-0600		Hex AB-Tap Scr. 5/16-24 x .5"
13	750-0762		Spacer 1" I.D. x 1.25" O.D.	54	712-0206		Hex Nut 1/2-13 Thd.
14	983-0101		Lift Shaft Ass'y.	55	14399		Deck Link
15	13895		Lift Pivot Brkt. Ass'y.	57	736-0219		Bell-Wash. .4" I.D. x 1.13" O.D.
16	17303		Adj. Deck Lift Link	59	783-0023A	N	Heat Shield
17	736-0192		FI-Wash. 1/2" I.D. x 1.00" O.D. x .090"	63	736-0329		L-Wash. 1/4" I.D.*
				65	751-0535-60		Fuel Line 60" Lg.
18	714-0101		Hairpin Cotter	66	726-0205		Hose Clamp
19	741-0591		Flange Brg. .63" I.D.	67	710-0776		Hex AB-Tap Scr. 1/4 x .62" Lg.
20	738-0445		Shld. Bolt 5/8" Dia. x .96" Lg. 3/8-16	68	17424		Fuel Tank Strap
				69	751-0566		Gas Tank
21	13790		Connecting Link	70	751-0531B		Gas Gauge
22	714-0142		Cotter Pin 3/16" Dia. x 1.5" Lg.	71	683-0101A	N	Seat Plate
25	710-1007		Hex TT-Tap 3/8-16 x 1.5" Lg.	72	17344A		Hitch Plate
26	710-0726		Hex Thd. Rolling Scr. 5/16-18 x .75" Lg.	73	738-0482		Hitch Rod
				75	727-0425A		Spring Clip
27	738-0435		Running Board Rod	77	726-0272		Hose Clamp
28	726-0272		Clamp	78	17958		Muffler Mounting Brkt.
29	734-0255		Air Valve	79	710-0258		Hex Bolt 1/4-20 x .85" Lg.
30	634-0086		Rear Wheel Ass'y. Comp.	82	710-0604		Hex TT-Tap Scr. 5/16"-18 x .62"
	734-1728		Tire Only	85	783-0280		Heat Shield
31	734-1015		Rear Wheel Rim Only	87	714-0120		Sq. Key 1/4" x 3" Lg.
32	736-0345		Flat Washer	90	751-0608		Exhaust Pipe
33	710-0258		Hex Bolt 1/4-20 x .62" Lg.	91	722-0199		Foam Seal (2 on Hood)
34	711-0817		Eye Bolt Adj. Link 1/2-13 Thd.	92	710-1246		Hex Tap Scr. #8-32 x .5" Lg.
36	712-0158		Hex Cent. L-Nut 5/16-18 Thd.	93	683-0098		Pivot Brkt. Ass'y.—R.H.
37	710-0237		Hex Bolt 5/16-24 x .62" Lg.*	94	683-0097		Pivot Brkt. Ass'y.—L.H.
39	712-0181		Hex Top L-Nut 3/8-16 Thd.	95	726-0328		Grommet
40	732-0369		Compression Spring	96	783-0279		Engine Mtg. Spacer
41	738-0777A		Deck Connecting Rod	97	721-0377		Gasket
42	712-3006		Hex Nut 1/4-20 Thd. (Gr. 5)	98	712-3086		Flange Nut M8 x 1.25 Thd.
43	14170		Index Brkt. Reinforcement Plate	99	712-0271		Hex Sems Nut 1/4-20 Thd.

\* For faster service obtain standard nuts, bolts and washers locally. If these items cannot be obtained locally, order by part number and size as shown on parts list.

# Model 147W834H

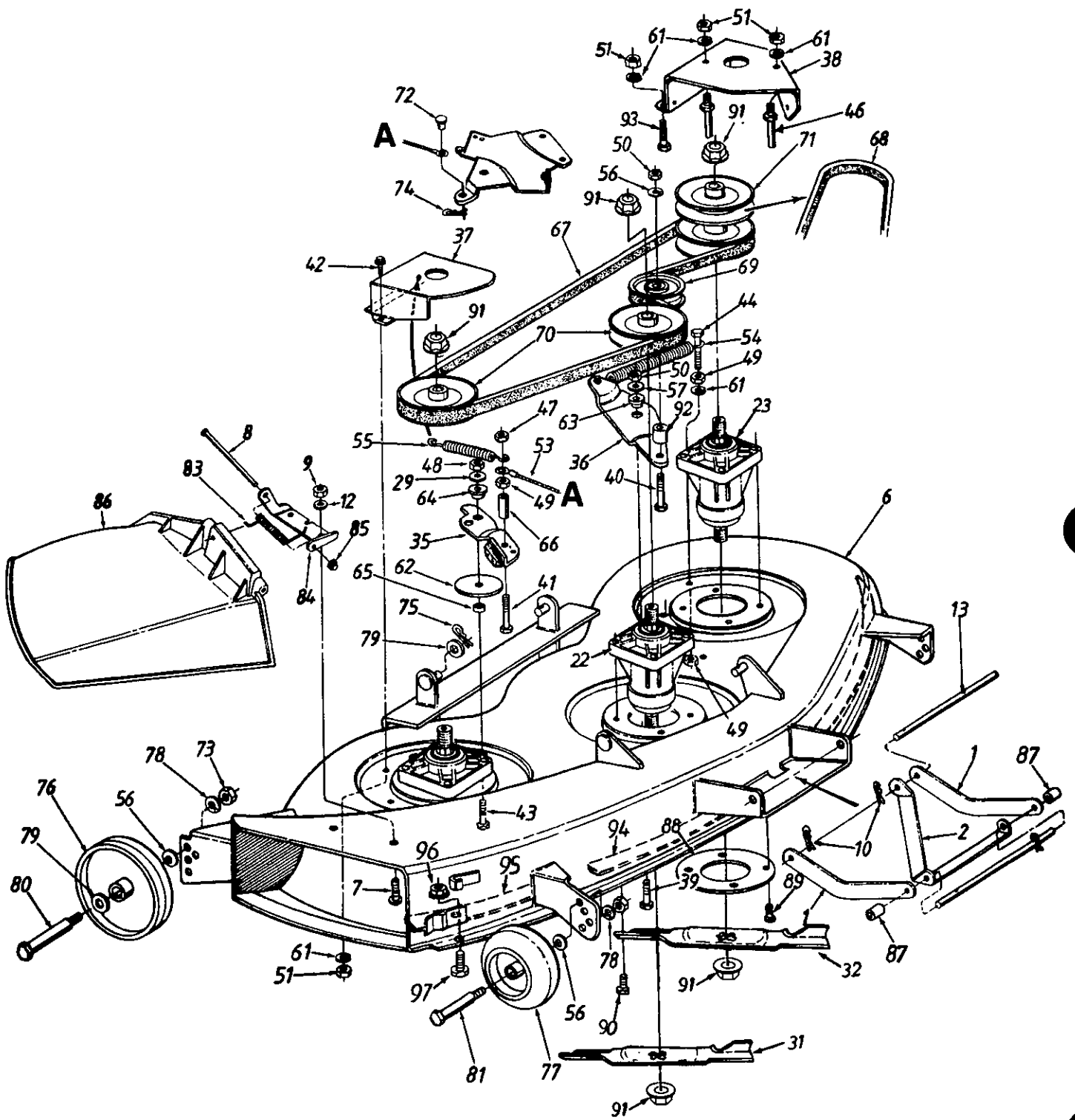



# Model 147W834H

## PARTS LIST FOR 46" MOWING DECK

REF. NO.	PART NO.	CODE	DESCRIPTION	REF. NO.	PART NO.	CODE	DESCRIPTION
1	17347		Deck Stabilizer	63	738-0347		Shld. Spacer .625" I.D.
2	17264		Diagonal Brace	64	748-0234		Shld. Spacer
6	683-0052		46" Deck Ass'y. Comp.	65	750-0214		Spacer .34" I.D.
7	710-0258		Hex Bolt 1/4-20 x .62" Lg.	66	750-0470		Spacer .326" I.D.
8	711-0792		Hinge Pin	67	754-0349		V-Belt
9	712-3006		Hex Nut 1/4-20 Thd. (Gr. 5)	68	754-0350		V-Belt
10	714-0149B		Hairpin Clip	69	756-0627		FI-Idler Pulley 3.5" O.D.
12	736-0270		Bell-Wash. 1/4" I.D.	70	756-0969		Pulley 5.0" Dia.
13	738-0392		Deck Connecting Rod	71	756-0977		Double Pulley 5.0" Dia.
22	618-0240	N	Spindle Ass'y. (R.H. & Center)	72	711-0701		Clevis Pin 1/4" Dia. x .53" Lg.
23	618-0241	N	Spindle Ass'y. (L.H.)	73	712-0798		Hex Nut 3/8-16 Thd.
29	736-0119		Lock Wash. 5/16" I.D.*	74	714-0104		Intern. Cotter Pin 5/16" Dia.
31	742-0645	N	Blade 14.88" Lg. (Middle)	75	714-0145		Intern. Cotter Pin 3/8 Dia.
32	742-0644	N	Blade 16.28" Lg. (R.H. & L.H.)	76	734-0973		Deck Wheel 5" Dia.
35	17116		Deck Brake Brkt. Ass'y.	77	734-3058B		Deck Wheel w/Insert 5" Dia.
36	17213		Idler Bracket	78	736-0169		L-Wash. 3/8" I.D.*
37	17258A		Belt Cover Brkt.—R.H.	79	736-0192		FI-Wash. .531" I.D.
38	783-0066A		Belt Cover—L.H.	80	738-0533		Shoulder Bolt .498" Dia. x 1.64" Lg.
39	710-0152		Hex Bolt 3/8-24 x 1.0" Lg.				Shoulder Bolt
40	710-0151		Hex Bolt 3/8-24 x 2" Lg.	81	738-3056		Torsion Spring
41	710-0559		Hex Bolt 1/4-28 x 1.75" Lg.	83	732-0602		Hinge Mtg. Brkt.
42	710-0599		Hex Wash. Hd. Tap-Scr. 1/4-20 x .5" Lg.	84	703-1693		Push Nut
				85	726-0106		Chute Ass'y. Comp. (Incl. Ref. 8, 83, 84, 85, 86)
43	710-0624		Hex Bolt 5/16-24 x 1.5" Lg. (Grade 5)	86	731-1032		Spacer 5/8" I.D. x 7/8" O.D.
44	710-0698		Hex Bolt 1/4-28 x 1.5" Lg.	87	750-0932A	N	Spindle Reinforcement Plate
46	711-0993		Belt Guard Pin 1/4" Dia.	88	17982		Hex Wash. Hd. Scr. 5/16-18 x 1" Lg.
47	712-0117		Hex Cent. L-Nut 1/4-28 Thd.	89	710-0650		Hex Wash. Hd. Scr. 5/16-18 x .75" Lg.
48	712-0123		Hex Nut 5/16-24 Thd.				Hex Flange Nut 5/8-18 Thd.
49	712-0138		Hex Nut 1/4-28 Thd.	90	710-1260		Spacer .38" I.D.
50	712-0241		Hex Nut 3/8-24 Thd.				Hex Bolt 1/4-20 x .5" Lg.
51	712-3006		Hex Nut 1/4-20 Thd. (Gr. 5)	91	712-0417A		Skirt—Center
53	727-0426		Brake Cable Ass'y.	92	711-0242		Skirt—Right Hand
54	732-0594A		Extension Spring 6.17" Lg.	93	710-0289		Hex Sems Nut 1/4-20 Thd.
55	732-0429A		Extension Spring 3.97" Lg.	94	783-0141		Carriage Bolt 1/4-20 x .5" Lg.
56	736-0105		Bell-Wash. .38" I.D. x .88" O.D.	95	783-0142		
57	736-0331		Bell-Wash. .39" I.D. x 1.13" O.D.	96	712-0271		
61	736-0329		L-Wash. 1/4" I.D.*	97	710-0167		
62	736-0416		FI-Wash. 5/16" I.D. x 3" O.D.				

\* For faster service obtain standard nuts, bolts and washers locally. If these items cannot be obtained locally, order by part number and size as shown on parts list.

# Model 147Y834P

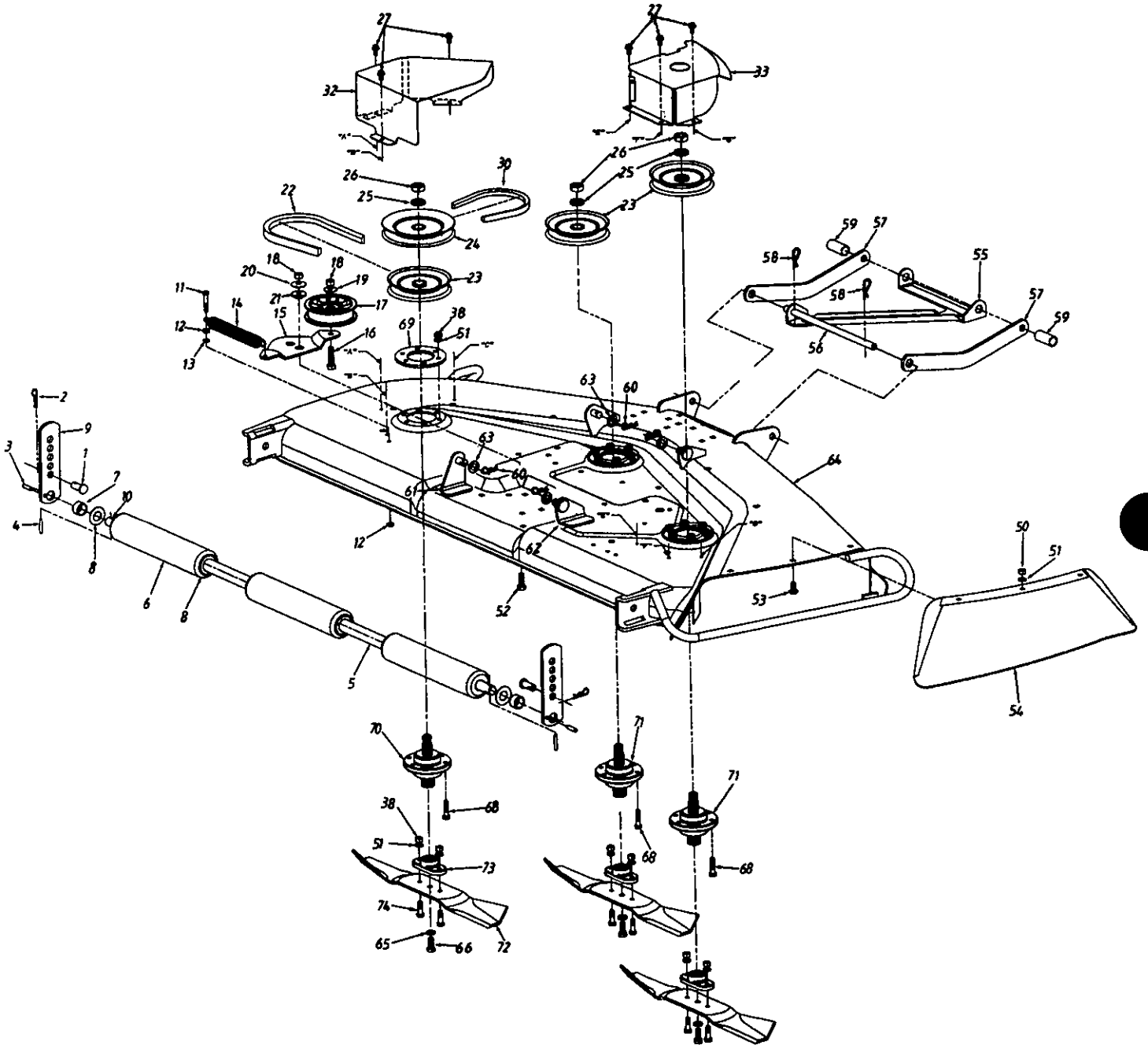

# Model 147Y834P

## PARTS LIST FOR 50" MOWING DECK

REF. NO.	PART NO.	CODE	DESCRIPTION	REF. NO.	PART NO.	CODE	DESCRIPTION
1	711-0310		Clevis Pin	30	754-0364		"V"-Belt
2	714-0101		Hairpin Clip	32	783-0131		Belt Guard—L.H.
3	715-0108		Spring Pin 1/4" x 1" Lg.	33	783-0130		Belt Guard—R.H.
4	715-0246		Spring Pin 3/16" x 1-1/4" Lg.	38	712-3057		Hex Nut 5/16-24 Thd. (Gr. 5)
5	750-0288		Spacer .82" I.D.	50	712-0267		Hex Nut 5/16-18 Thd.*
6	731-0335		Deck Roller	51	736-0119		L-Wash. 5/16" I.D.*
7	750-0212		Spacer .75" I.D.	52	710-0152		Hex Bolt 3/8-24 x 1" Lg.
8	736-0188		Fl-Wash. .76" I.D. x 1.5" O.D.	53	710-0451		Carr. Bolt 5/16-18 x .75" Lg.
9	12650		Height Adjuster	54	12649		Chute Guard
10	738-0295		Roller Shaft	55	17264		Diagonal Brace
11	710-0698		Hex Bolt 1/4-28 x 1.5" Lg. (Gr. 5)	56	738-0392		Connecting Rod
12	712-0138		Hex Nut 1/4-28 Thd.	57	17347		Stabilizer Link
13	736-0329		L-Wash. 1/4" I.D.	58	714-0149B		Hairpin Clip
14	732-0594A		Ext. Spring 7.33" Lg.	59	750-0932A		Spacer 1.75" Lg.
15	783-0139		Idler Brkt.	60	714-0145		Hairpin Clip
16	710-0459		Hex Bolt 3/8-24 x 1.5" Lg.	63	736-0192		Fl-Wash. 1/2" I.D. x .93" O.D.
17	756-0627		Idler Pulley	64	983-0060		Deck Ass'y.
18	712-0241		Hex Nut 3/8-24 Thd.	65	736-0217		L-Wash. 3/8" I.D.—H.D.
19	736-0105		Bell-Wash. 3/8" I.D.	66	710-0877		Hex Bolt 3/8-24 x .88" Lg. (Gr. 5)
20	736-0331		Bell-Wash. .39" I.D. x 1.13" O.D.	68	710-0672		Hex Bolt 5/16-24 x 1-1/4" Lg. (Gr. 5)
21	738-0347		Shld. Spacer .625" I.D.				
22	754-0291A		"V"-Belt	69	14249A		Spindle Reinforcement Plate
23	756-0519		Deck Pulley	70	918-0119		Spindle Ass'y. (L.H.)
24	756-0604		Upper Deck Pulley	71	918-0118		Spindle Ass'y. (R.H. & Center)
25	736-0158		L-Wash. 5/8" I.D.	72	742-0171B		Blade
26	712-0318		Hex Jam Nut 5/8-18 Thd.	73	748-0300		Blade Adapter
27	710-0599		Hex Tap Scr. 1/4-20 x .5"	74	710-0888		Hex Bolt 5/16-24 x 1" Lg.

# Model 147W834H

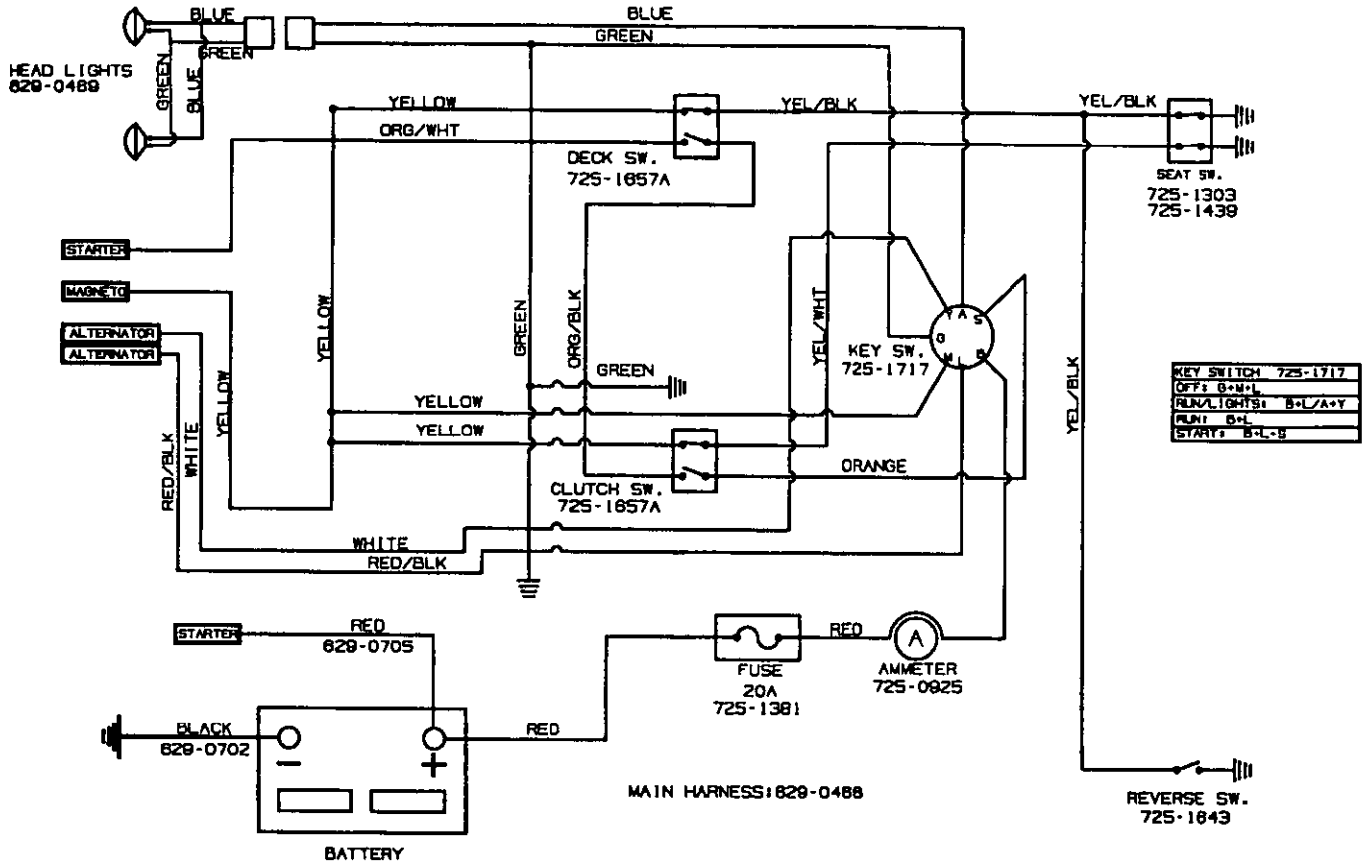

# Model 147Y834P

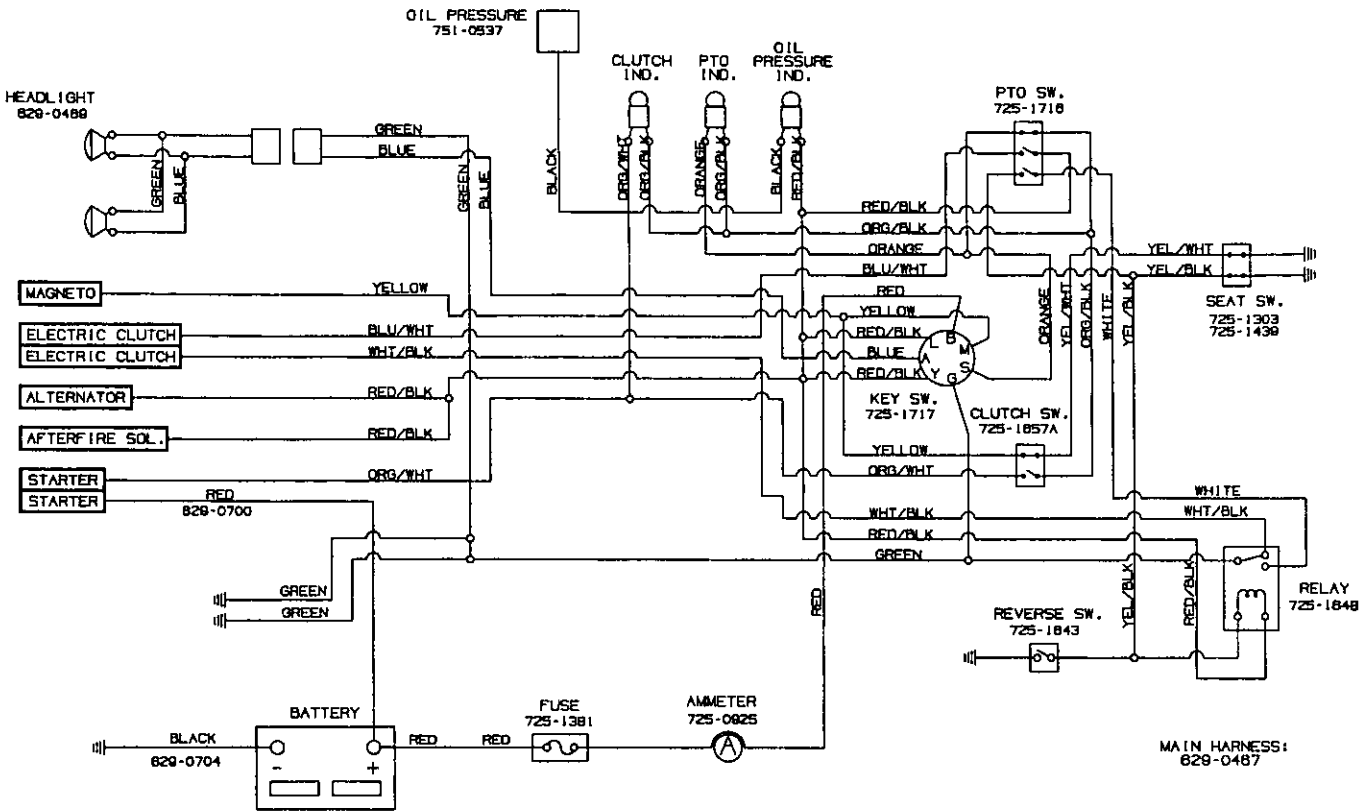



# MANUFACTURER'S LIMITED WARRANTY FOR:



For TWO YEARS from the date of retail purchase within the United States of America, its possessions and territories, MTD Products will, at its option, repair or replace, for the original purchaser, free of charge, any part or parts found to be defective in material or workmanship. This warranty covers units which have been operated and maintained in accordance with the owner's instructions furnished with the unit, and which have not been subject to misuse, abuse, commercial use, neglect, accident, improper maintenance or alteration.

Normal wear parts or components thereof are subject to separate terms as noted below in the "No Fault Ninety Day Consumer Warranty" clause.

All normal wear part failures will be covered on this product for a period of 90 days regardless of cause. After 90 days, but within the two year period, normal wear parts failures will be covered ONLY IF caused by defects in material or workmanship of OTHER component parts. Normal wear parts are defined as batteries\*, belts, blades, blade adapters, grass bags, rider deck wheels, seats, snow thrower skid shoes, shave plates and tires.

**How to obtain service:** Warranty service is available, with proof of purchase, through your local authorized service dealer. To locate the dealer in your area, please check the yellow pages or contact the Customer Service Department of MTD Products, P O Box 368022, Cleveland, Ohio 44136-9722.

Phone 1 (800) 800-7310. The return of a complete unit will not be accepted by the factory unless prior written permission has been extended by the Customer Service Department of MTD Products.

**Transportation charges:** Transportation charges for the movement of any power equipment unit or attachment are the responsibility of the purchaser.

**Units exported out of the United States:** MTD Products does not extend any warranty for products sold or exported outside of the United States of America, its possessions and territories, except those sold through MTD Products' authorized channels of export distribution.

#### Other Warranties:

1. The engine or component parts thereof carry separate warranties from their manufacturers. Please refer to the applicable manufacturer's warranty on these items.
2. \*Batteries are covered by a 90-day replacement warranty.
3. Log splitter pumps, valves and cylinders or component parts thereof are covered by a one year warranty.
4. All other warranties, express or implied, including any implied warranty of merchantability or fitness for a particular purpose, are hereby expressly disclaimed in their entirety.
5. The provisions as set forth in this warranty provide the sole and exclusive remedy of MTD Products' obligations arising from the sales of its products. MTD Products will not be liable for incidental or consequential loss or damage.

**How state law relates to this warranty:** This limited warranty gives you specific legal rights, and you may also have other rights which vary from state to state. Certain disclaimers are not allowed in some states and therefore they may not apply to you under all circumstances.

**Note:** This warranty does not cover routine maintenance items such as lubricants, filters, blade sharpening and tune-ups, or adjustments such as brake adjustments, clutch adjustments or deck adjustments. Nor does this warranty cover normal deterioration of the exterior finish due to use or exposure.

