

Parts Manual for

SNAPPER®

YARD TRACTOR ELECTRIC CLUTCH HYDRO DRIVE RMO & ACS "RD" SERIES 0

MODEL
RD18S40 (2690624)
RD18VG40 (2690623)

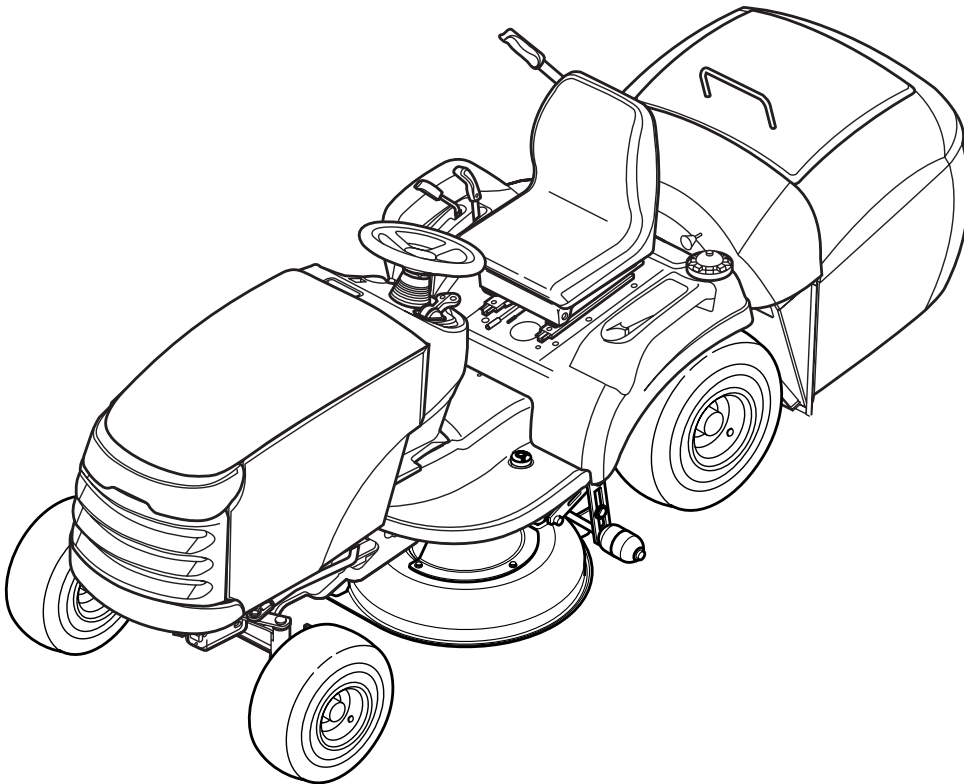

SNAPPER® McDonough, GA, 30253 U.S.A.

PAGE	GROUP
4	Wheels & Tires Group
6	Hood, Grille & Dash Group
8	Steering Group
10	Frame & Front Axle Group
14	Controls Group
18	Cruise Control Group
20	Transmission Group - Tuff Torq K-46BF
24	Seat Deck & Fuel Tank Group
26	Engine Group - 18 HP INTEK Single Cyl.
28	Engine Group - 18 HP & 20 HP VANGUARD Twin Cyl.
30	40" Mower Deck - Belt, Idle Arm & Hitch
32	40" Mower Deck - Housing, Arbors & Blade
34	40" Mower Deck - Height Adjustment & Roller Bar
38	Hopper Group
42	Deflector Group
44	Decals Group
46	Electrical Group

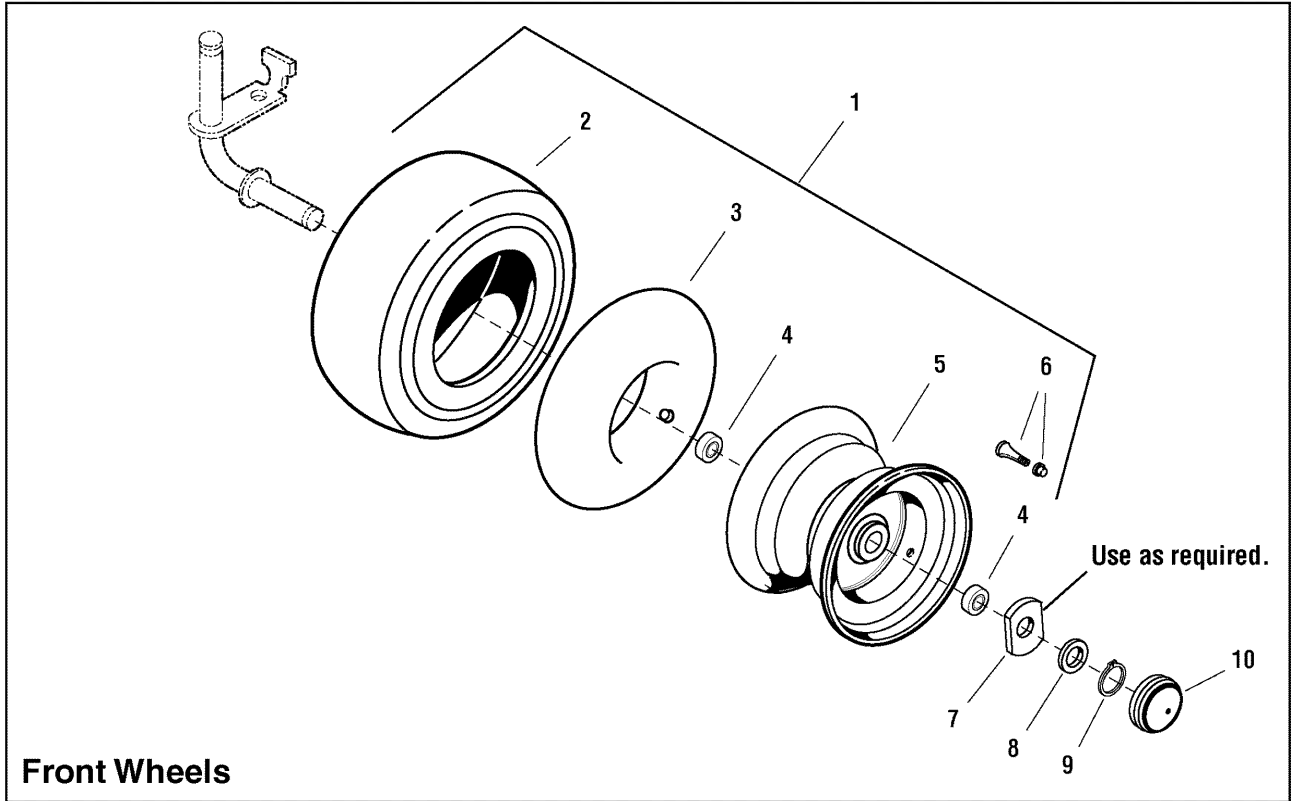

Front Wheels

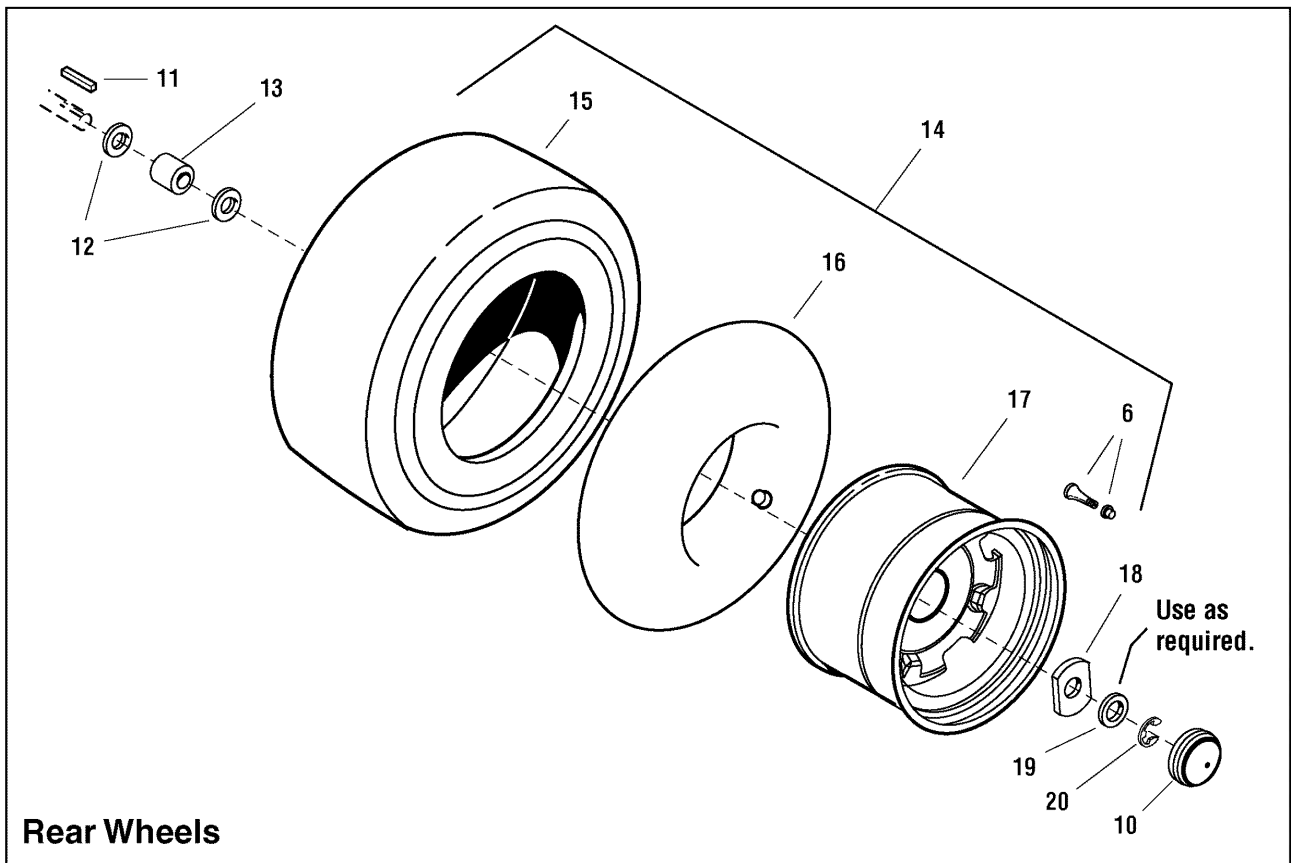

Rear Wheels

Wheels & Tires Group

Item	Part No	Qty	Description	Note
1	1722065	2	WHEEL & TIRE ASSEMBLY, Front	<i>(Includes Ref. Nos. 2, 3, 4, 5)</i>
2	1722838	1	TIRE, 15 x 6, Super Turf	
3	1664090	1	TUBE, Tire, Front, 4.10/3.50	
4	1717056	2	BEARING, Ball	
5	1722837	1	WHEEL, 4-1/2" x 6"	
6	2172353	4	VALVE STEM & CAP ASSEMBLY	
7	1722726A	4	WASHER, Special, (As Required)	
8	1919394	4	WASHER, 1, (As Required)	
9	2932577	2	RING, Retaining, External #98	
10	1722676	4	CAP, Hub, Gray	
11	1729279	2	KEY, Parellel, 3/16 x 3/16 x 1-1/2	
12	2960202	4	WASHER, 3/4	
13	1709527	2	SPACER	
14	1721694	2	WHEEL & TIRE ASSEMBLY	
15	1722826	1	TIRE, 20 x 10, 8 Super Turf	
16	2173477	1	TUBE, Tire, 20 x 8, Rear	
17	1722835	1	WHEEL, 7 x 7.96, W/ 3/4 OD Shaft	
18	1722717A	2	WASHER, Special	
19	1960114	2	WASHER, 3/4	
20	2927794	2	RING, "E" External	

Footnotes:

Hood, Grille & Dash Group

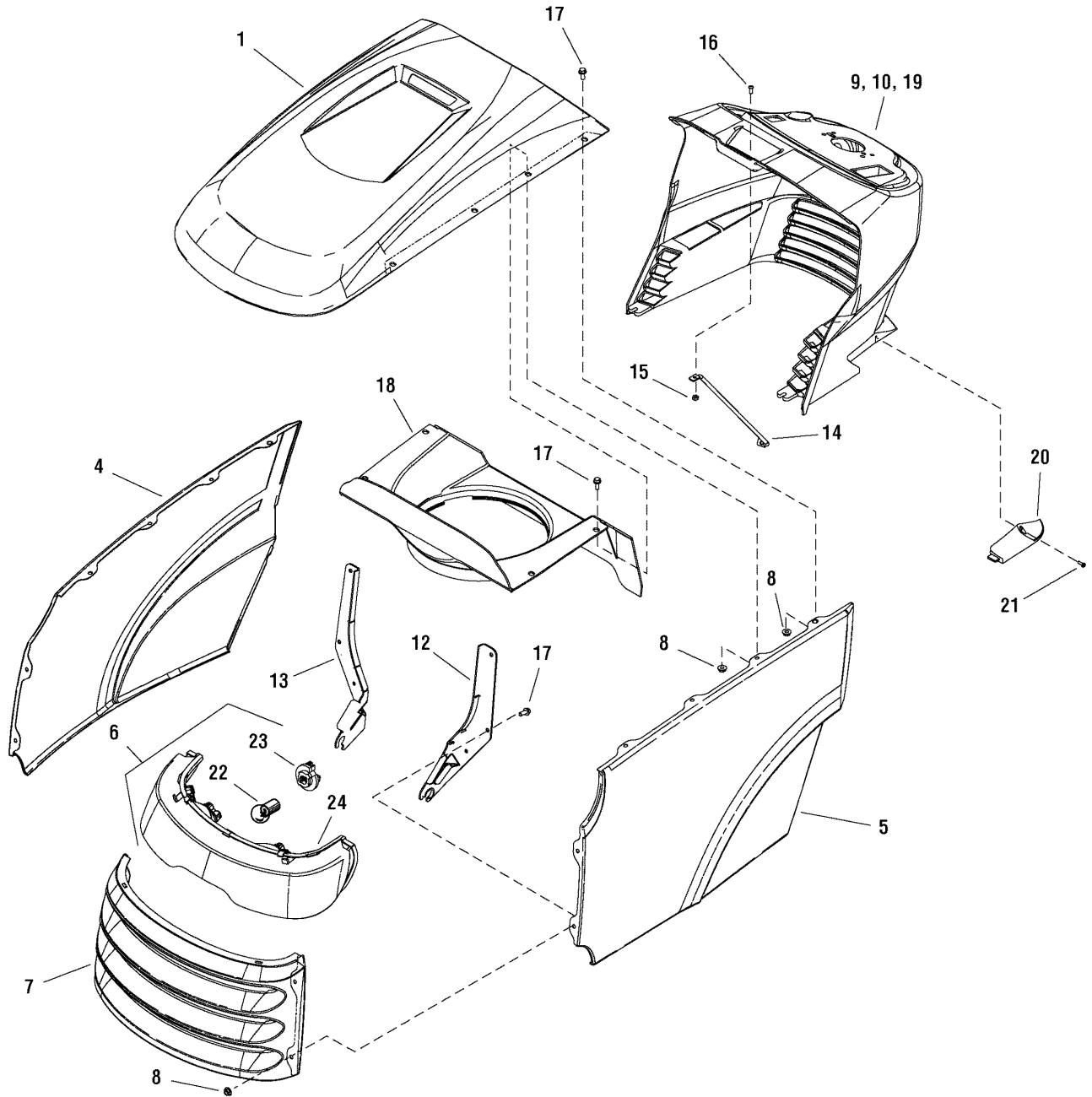

Hood, Grille & Dash Group

Item	Part No	Qty	Description	Note
1	1728031D	1	HOOD, W/Scoop	
4	1721804D	1	PANEL, R.H. Side	
5	1721803D	1	PANEL, L.H. Side	
6	1721810	1	HEADLIGHT ASSEMBLY	<i>(Includes Ref. Nos. 22, 23 & 24)</i>
7	1721802D	1	GRILLE	
8	1930641	12	NUT, Hex Flange 1/4-20 Whiz Lock	
9	1726827	1	DASHBOARD	<i>(Used only on YT & LT models)</i>
10	1726894	1	DASHBOARD, W/Hydraulic Lift Slot	<i>(Used only on GT models)</i>
12	1721808A	1	HINGE, Hood L.H.	
13	1721809A	1	HINGE, Hood R.H.	
14	1723123	1	ROD, Dash Support	
15	1933896	1	NUT, Hex Lock 10-24 w/Nylon Insert	
16	1960392	1	SCREW, Pan Head Phillips #10-24 x 1	
17	1960295	12	SCREW, Hex Whiz Lock Flange 1/4-20 x 5/8	
18	1733457A	1	DUCT, Air Inlet	
19	1726895	1	DASHBOARD, w/Buzzer Hole	<i>(Used only on Barons models)</i>
20	1722285	1	COVER, Dash	<i>(Used only on Barons models)</i>
21	1722607	1	SCREW, Pan Head Torx #8-16 x 1/2 Plastite	<i>(Used only on Barons models)</i>
22	1677371	4	BULB, Headlight	
23	1723451	4	SOCKET ASSEMBLY, Seal	
24	1722902	1	REFLECTOR, Headlight	

Footnotes:

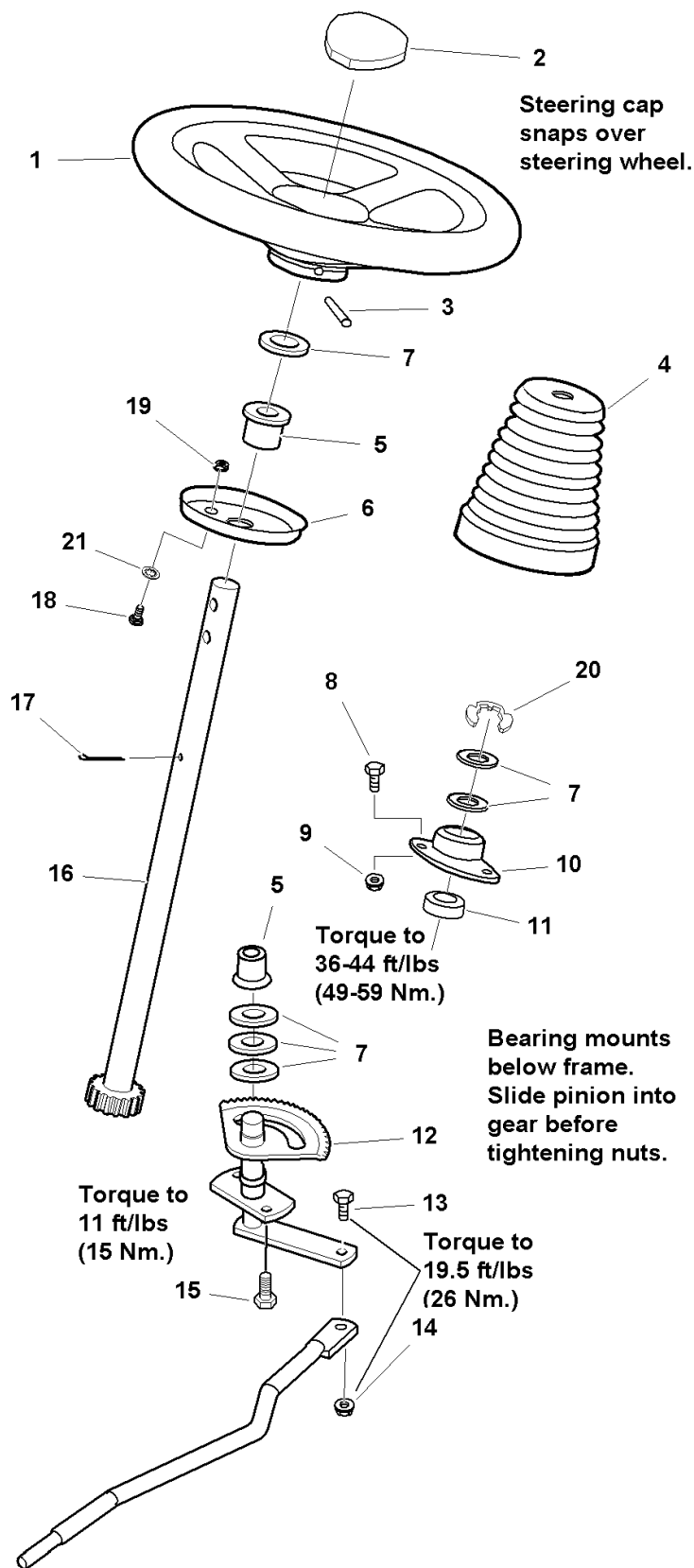

Steering Group

Item	Part No	Qty	Description	Note
1	1722318	1	STEERING WHEEL, Straight Shaft	
2	1725024	1	CAP, Steering Wheel, Plain	
3	1960540	1	PIN, Spring	
4	1722749	1	COVER, Black Rubber	
5	2176440	2	BUSHING	
6	1721736A	1	PLATE, Mounting Steering	
7	1960114	6	WASHER	
8	1933260	2	CAPSCREW, Hex Head Flange Lock, 3/8-16 x 3/4	
9	1931211	2	NUT, Hex Whiz Lock, 3/8-16	
10	1722459	1	BEARING, Flange	
11	1722461	1	SPACER	
12	1724470A	1	GEAR & SHAFT ASSEMBLY	
13	1960032	1	CAPSCREW, Hex Head, 3/8-16 x 1-1/4	
14	1930645	1	NUT, Hex Flange Lock, 3/8-16	
15	1664847	2	CAPSCREW, Hex Head Taptite, 5/16-18 x 3/4	
16	1723604	1	SHAFT ASSEMBLY	
17	1919314	1	PIN, Cotter	
18	1931317	2	CARRIAGE BOLT, 1/4-20 x 3/4	
19	2928372	2	NUT, Hex, 1/4-20	
20	1611710	1	RING, Clipring Extension	
21	1960114	2	WASHER	

Footnotes:

Frame & Front Axle Group

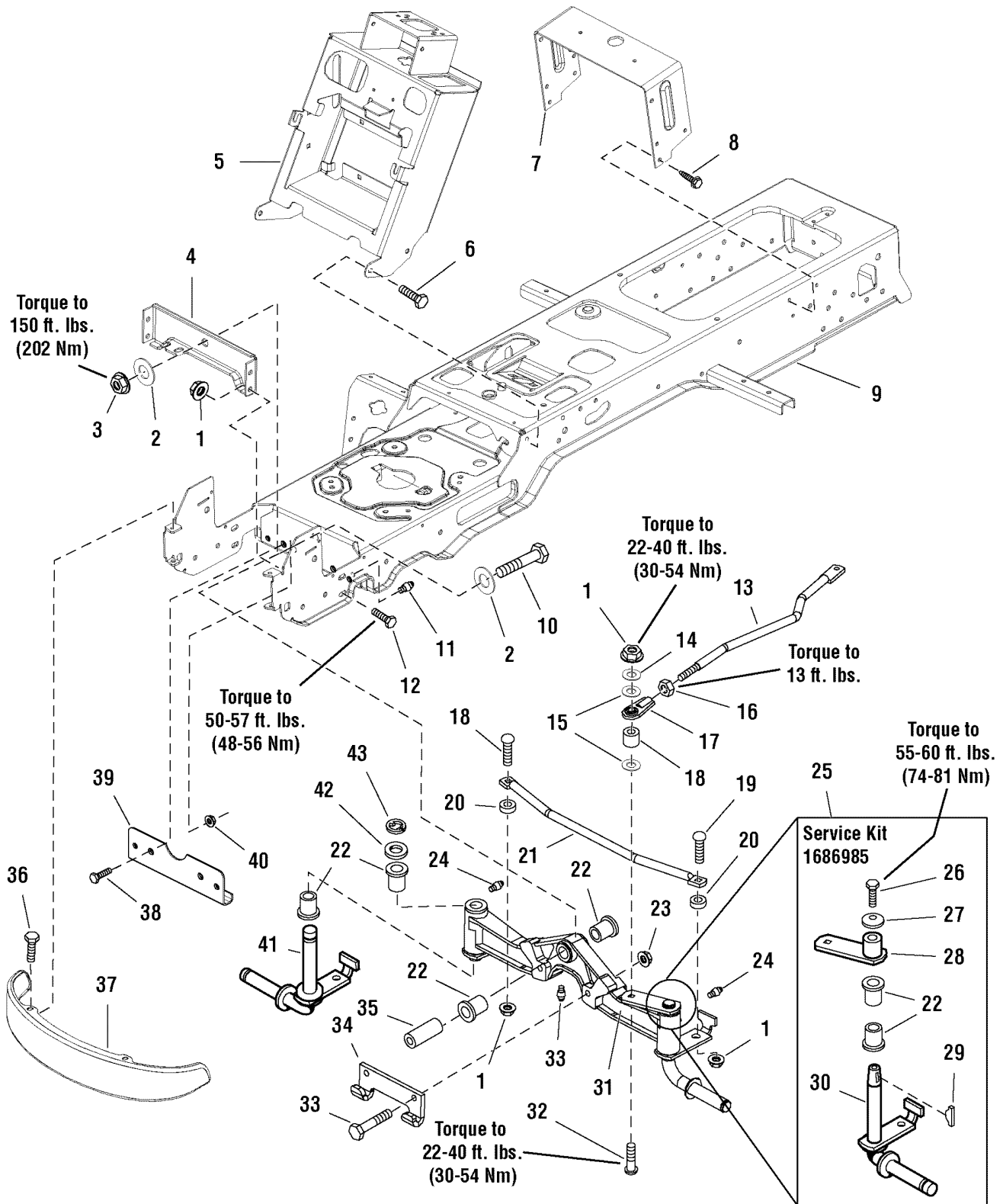

Frame & Front Axle Group

Item	Part No	Qty	Description	Note
1	1930645	7	NUT, Hex Flange Lock, 3/8-16	
2	1960035	2	WASHER	
3	2960646	1	NUT, Hex Flange, 5/8-11	
4	1722212A	1	PLATE, Axle	
5	1724081A	1	TOWER & SUPPORT ASSEMBLY	
6	1923683	4	CAPSCREW, Hex Head Taptite, 3/8-16 x 3/4	
7	1723528A	1	SUPPORT	
8	1664847	4	CAPSCREW, Hex Head Taptite, 5/16-18 x 3/4	
9	1727396A	1	FRAME ASSEMBLY	
10	2960645	1	CAPSCREW, 5/8-11 x 3-1/2	
11	1704314	2	FITTING, Grease for Wear Plate, 1/4-20, with Ball	
12	1933260	4	CAPSCREW, Hex Head, Flange Lock, 3/8-16 x 3/4	
13	1722541	1	LINK, Drag	
14	1922755	1	WASHER	
15	1960103	2	WASHER	
16	1919262	1	NUT, Hex Jam, 1/2-20	
17	1702779A	1	JOINT, Ball	
18	1708236	1	SPACER	
19	1931350	2	CARRIAGE BOLT, 3/8-16 x 1	
20	1611705	2	SPACER	
21	1722626A	1	ROD, Tie	
22	1721682	6	BUSHING	
23	1930650	2	NUT, Hex Flange Lock, 7/16-14	
24	1704314	3	FITTING, Lube	
25	1686985	1	SPINDLE REPLACEMENT KIT, LH	(Includes Ref. Nos. 22, 26, 27)
26	2823485	1	CAPSCREW, 3/8-16 x 7/8, GR8	
27	1663151	1	WASHER, Spring, 3/8	
28	1725112	1	HUB & ARM ASSEMBLY	
29	2830671	1	KEY, Woodruff	
30	1724264	1	SPINDLE, LH	
31	1722200A	1	AXLE ASSEMBLY, w/ LH Spindle, Complete	(Includes Ref. Nos. 2)
32	1931352	1	CARRIAGE BOLT, 3/8-16 x 1-1/2	
33	1927531	2	CAPSCREW, Hex Head, 7/16-14 x 2, GR8	
34	1721918A	1	HOOK, "J"	
35	1721752	1	SPACER	
36	1960086	4	SCREW, Torx Head, 5/16-18 x 7/8	
37	1721805A	1	BUMPER, Black, Steel, Standard	

Footnotes:

Frame & Front Axle Group

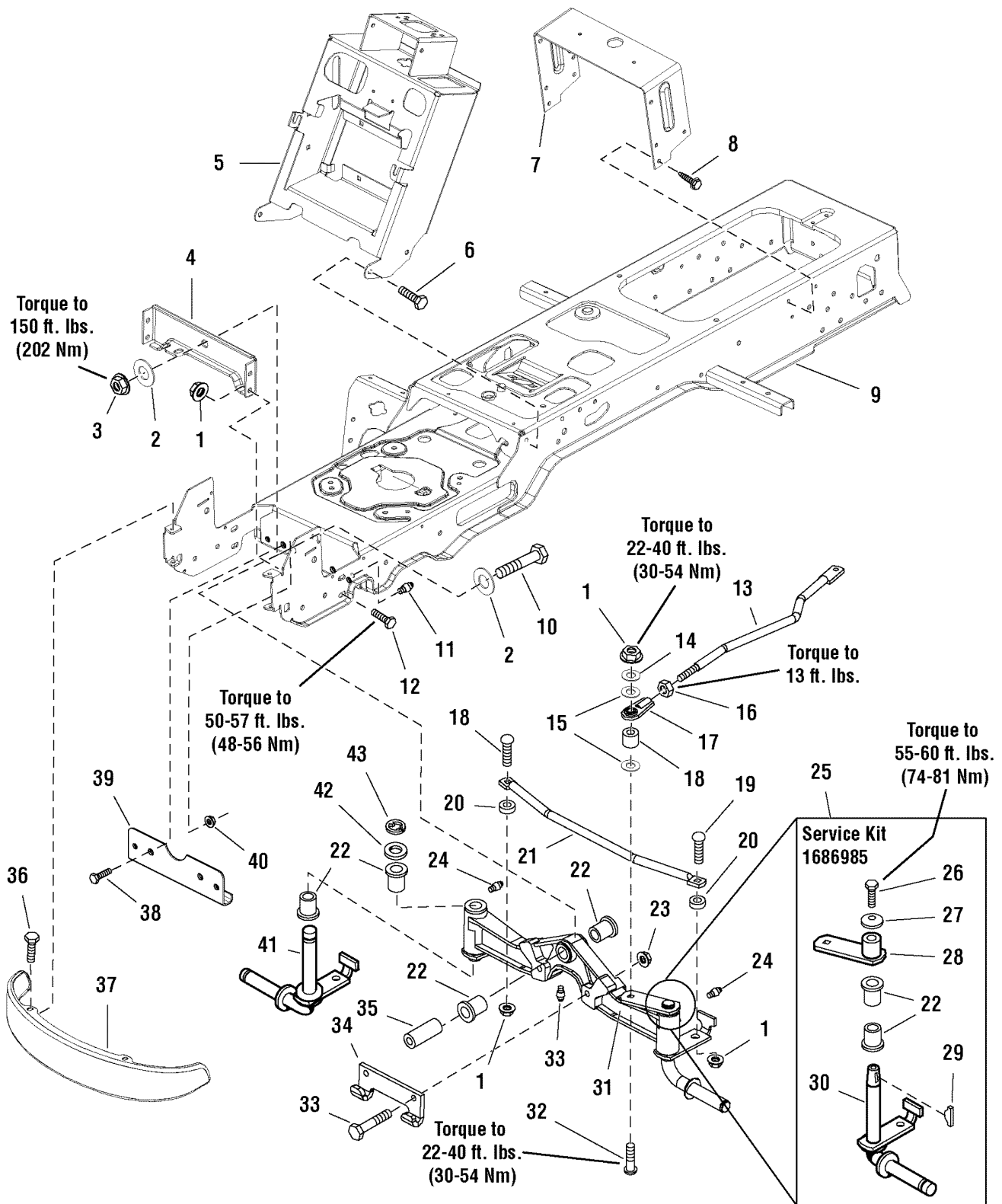

Frame & Front Axle Group

Item	Part No	Qty	Description	Note
37	1723502	1	BUMPER, Chrome, Optional	
38	1930591	2	CAPSCREW, Hex Whiz Lock, 5/16-18 x 3/4	
39	1724801A	1	PLATE, Axle Wear	
40	1931277	2	NUT, Hex Falnge Whiz Lock, 5/16-18	
41	1722199	1	SPINDLE, RH	
42	1919394	1	WASHER	
43	2932577	1	RETAINING RING	

Footnotes:

Controls Group

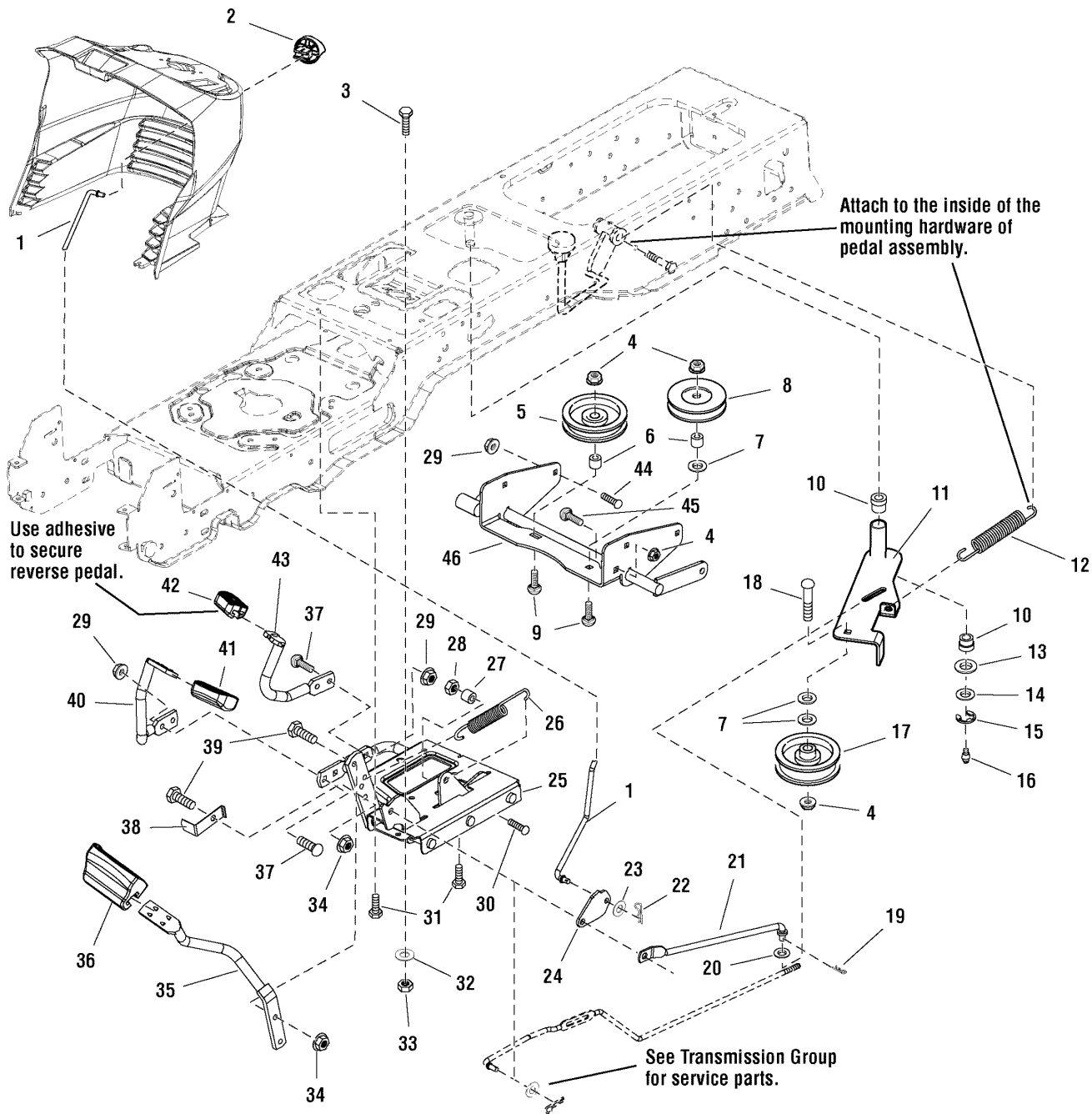

Controls Group

Item	Part No	Qty	Description	Note
1	1721353	1	ROD, Brake	
2	1721891	1	KNOB, Push On, Red	
3	1930591	1	CAPSCREW, Hex Head Flange Lock, 5/16-18 x 3/4	
4	1960687	3	NUT, Hex Flange, 3/8-16 ESNA	
5	1721134	1	PULLEY ASSEMBLY, 3 OD, W/Bearing	
6	1667811	2	SPACER	
7	1922755	3	WASHER, 3/8	
8	1710545	1	PULLEY, Idler 4 OD	
9	1960315	2	CARRIAGE BOLT, 3/8-16 x 2 G5	
10	1663114	2	BUSHING	
11	1727370	1	ARM & HUB ASSEMBLY, Idler	
12	1733844	1	SPRING, Extension	
13	1960020	1	WASHER, 5/8	
14	1924366	1	WASHER, 5/8	
15	1704420	1	RING, Clipping	
16	1704314	1	FITTING, Lube, 1/4 Ball Check	
17	1710539	1	PULLEY, Idler 3-1/4 OD	
18	1960315	1	CARRIAGE BOLT, 3/8-16 x 2 G5	
19	1918447	1	PIN, Cotter	
20	1924940	1	WASHER	
21	1727408	1	ROD, Brake (Flat Ends)	
22	1722460	1	PIN, Quick	
23	1919326	1	WASHER	
24	1721354A	1	LATCH, Brake	
25	1726763	1	CONTROL ASSEMBLY, Foot Pedal	
26	1721995	1	SPRING, Extension	
27	1686612	1	CAM, Roller	
28	1920397	1	NUT, Hex Lock ESNA, 1/4-20	
29	1960636	8	NUT, Hex KEPS, 5/16-18	
30	1931320	1	CARRIAGE BOLT, 1/4-20 x 1-1/4	
31	1664847	3	CAPSCREW, Hex head Washer Taptite, 5/16-18 x 3/4	
32	1919381	1	WASHER	
33	1919438	1	NUT, Hex Lock ESNA, 5/16-18	
34	1927557	3	NUT, Hex Flange Lock, 5/16-18	
35	1722535A	1	PEDAL, Brake	
36	1721577	1	PAD, Brake Pedal	
37	1931334	4	CARRIAGE BOLT, 5/16-18 x 7/8	

Footnotes:

Controls Group

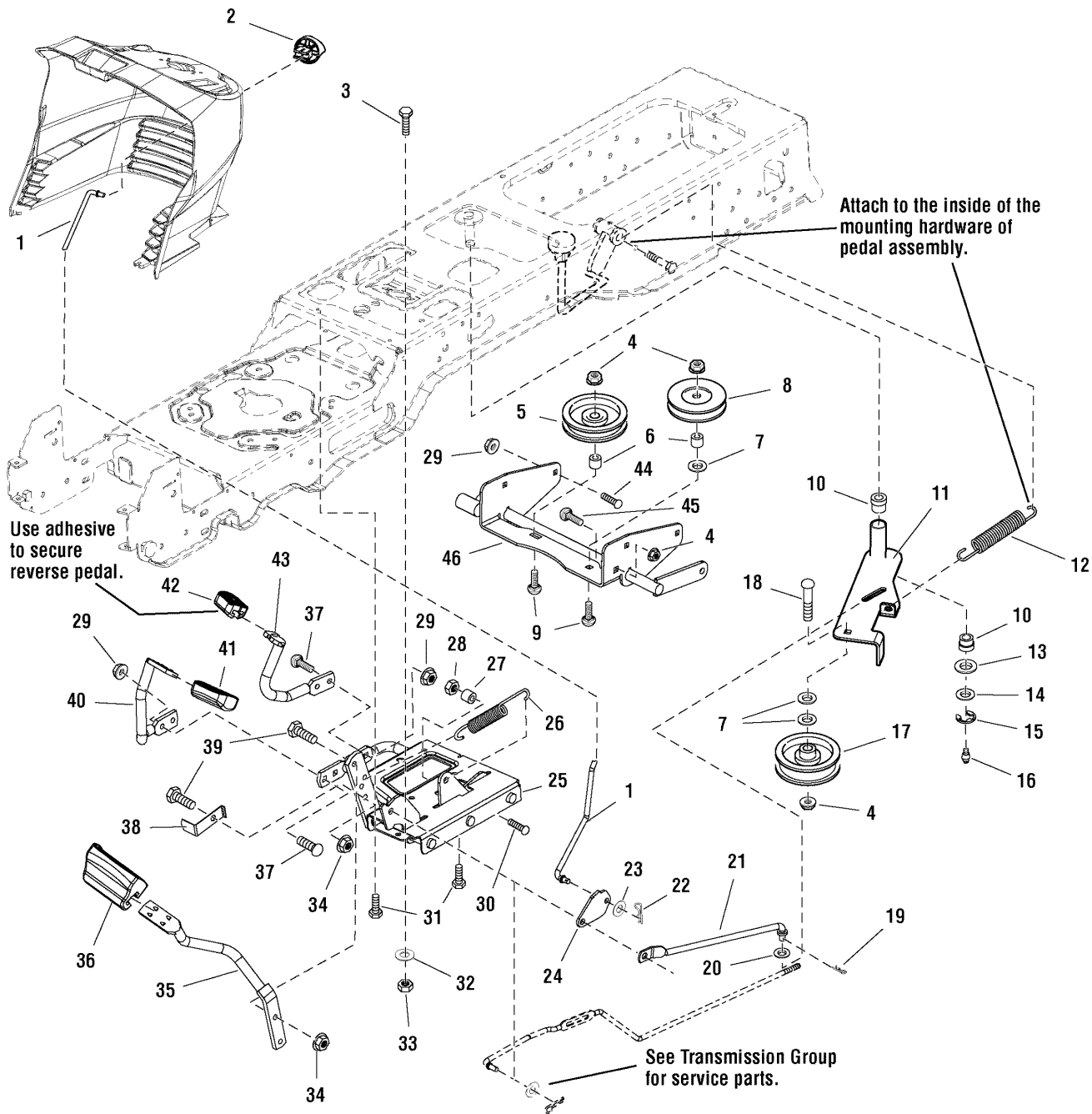

Controls Group

Item	Part No	Qty	Description	Note
38	1722083A	1	ACTUATOR, Switch	
39	1921333	3	CAPSCREW, Hex Head, 5/16-18 x 1	
40	1722070A	1	PEDAL, Forward	
41	1721675	1	PAD, Foot Pedal Forward	
42	1721674	1	PAD, Foot Pedal Reverse	
43	1722071A	1	PEDAL, Reverse	
44	1931333	4	CARRIAGE BOLT, 5/16-18 x 3/4	
45	1931348	1	CARRIAGE BOLT, 3/8-16 x 3/4	
46	1726087A	1	SUPPORT, Idler	

Footnotes:

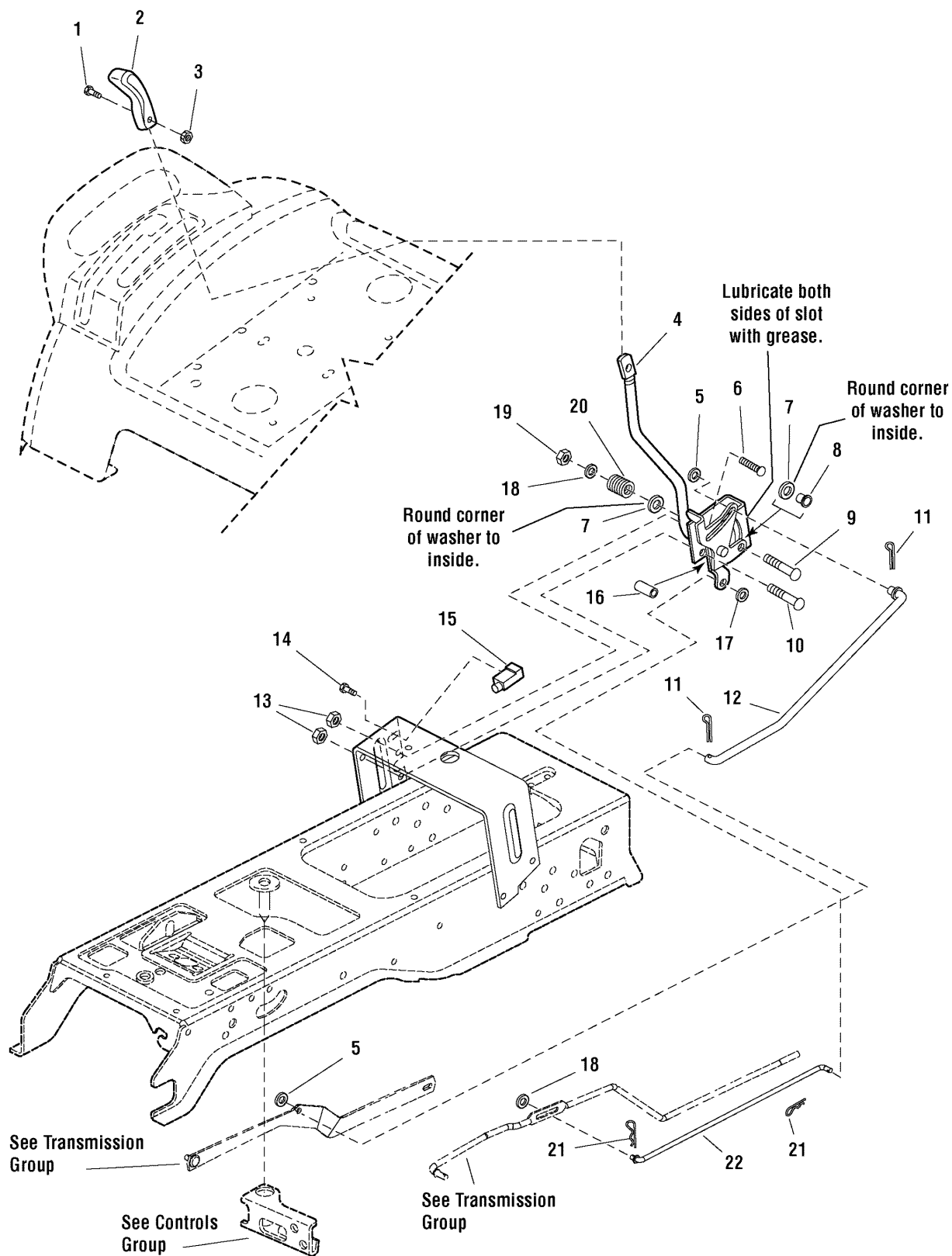

Cruise Control Group

Item	Part No	Qty	Description	Note
1	1960666	1	CAPSCREW, Torx Socket Head, 1/4-20 x 7/8	
2	1722303	1	KNOB, Cruise	
3	1920397	1	NUT, Hex ESNA Lock, 1/4-20	
4	1723258	1	LEVER & BRACKET ASSEMBLY, Cruise	
5	1960103	3	WASHER	
6	1931333	1	CARRIAGE BOLT, 5/16-18 x 3/4	
7	926192	2	WASHER, 9/16 x 1-1/4 x 1/8	
8	1709043	1	SPACER	
9	1931342	1	CARRIAGE BOLT, 5/16-18 x 2-3/4	
10	1960273	1	CARRIAGE BOLT, 5/16-18 x 2-1/4	
11	1918447	2	PIN, Cotter	
12	1726059	1	ROD, Cruise	
13	1960636	2	NUT, Hex KEPS, 5/16-18	
14	1960001	2	CAPSCREW, Hex Head Plastite, 10-14 x 5/8	
15	1717050	1	SWITCH, Push, Neutral Start, Gray	
16	1722080	1	SPACER	
17	1919326	1	WASHER	
18	1919381	2	WASHER	
19	1919438	1	NUT, Hex ESNA Lock, 5/16-18	
20	1677746	1	SPRING, Compression	
21	1722460	2	PIN, Quick	
22	1723099	1	ROD, Cruise Return	

Footnotes:

Transmission Group - Tuff Torq K-46BF

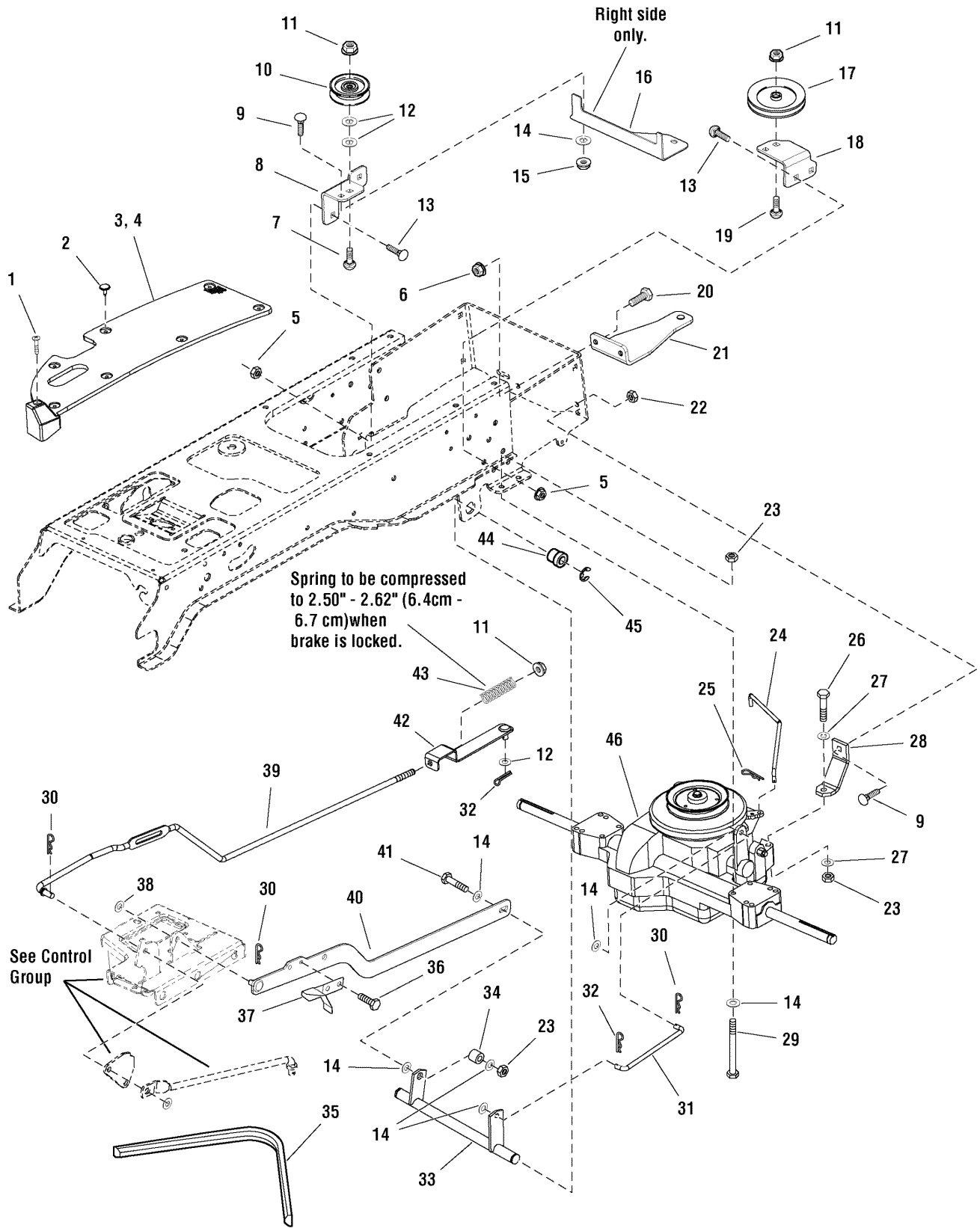

Transmission Group - Tuff Torq K-46BF

Item	Part No	Qty	Description	Note
1	1960676	2	SCREW, Pan Head Torx Taptite, 1/4-20 x 1-1/4	
2	1704351	15	FASTENER, Panel 3/4 Head	
3	1722173	1	PAD, Footrest, RH Black Vinyl Textured	
4	1722174	1	PAD, Footrest with Differential Lock, LH Black Vinyl Texture	
5	1960637	4	NUT, Hex KEPS, 3/8-16	
6	1928352	2	NUT, Hex Flange, 3/8-16 Whiz Lock Large	
7	1931353	1	CARRIAGE BOLT, 3/8-16 x 1-3/4 G5	
8	1726052A	1	SUPPORT, Idler, RH	
9	1931333	3	CARRIAGE BOLT, 5/16-18 x 3/4 G5	
10	2174561	1	PULLEY, 3 in.	
11	1960687	3	NUT, Hex Flange 3/8-16 ESNA	
12	1922755	3	WASHER, 3/4	
13	1931350	4	CARRIAGE BOLT, 3/8-16 x 1 G5	
14	1919326	10	WASHER, 5/16	
15	1960684	2	NUT, Hex KEPS, 5/16-18 Conical Washer	
16	1727431A	1	BRACKET, Chute Locator	
17	1710545	1	PULLEY, Idler, 4 in.	
18	1726053A	1	SUPPORT, Idler, LH	
19	1931352	1	CARRIAGE BOLT, 3/8-16 x 1-1/2 G5	
20	1921210	2	CAPSCREW, Hex Head, 3/8-16X1.000 G5 BLK	
21	1727400A	1	DRAWBAR, 1/4 in. Thick	
22	1960636	1	NUT, Hex KEPS, 5/16-18	
23	1919438	6	NUT, Hex Lock ESNA Light, 5/16-18NC-3B	
24	1727526	1	ROD, Transmission Release	
25	1960221	1	CLIP, Hair Pin Spring	
26	1921978	1	CAPSCREW, Hex Head, 5/16-18 x 2 G5	
27	1960141	2	WASHER, 5/16	
28	1726055A	1	STRAP, Torque, 1/4 Thick 4 in. Long	
29	1923141	4	CAPSCREW, Hex Head, 5/16-18 x 2-3/4 G5	
30	1722460	3	PIN, Quick	
31	1723045	1	ROD, Control	
32	1918447	2	PIN, Cotter	
33	1727552	1	SHAFT & ARMS ASSEMBLY, Control	
34	1666697	1	SPACER, Powered Metal	
35	1727407	1	V-BELT, Drive Belt	
36	1924856	2	CAPSCREW, Hex Washer Head Taptite, 5/16-18 x 1/2	
37	1727215A	1	ACTUATOR, Switch	

Footnotes:

Transmission Group - Tuff Torq K-46BF

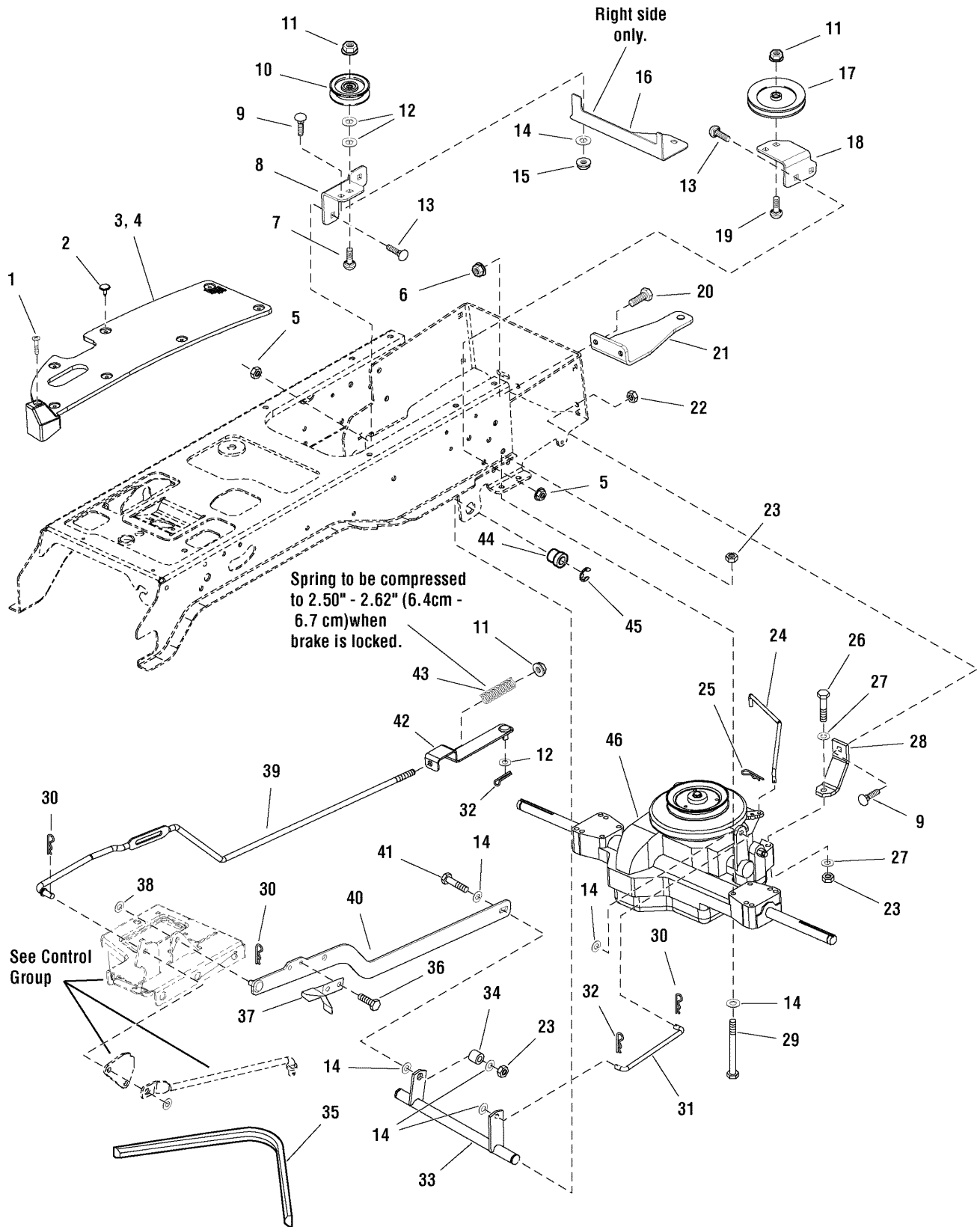

Transmission Group - Tuff Torq K-46BF

Item	Part No	Qty	Description	Note
38	1924940	1	WASHER, 3/8	
39	1726057	1	ROD, Brake	
40	1727473	1	ARM & PIN ASSEMBLY, Speed Control	
41	1921333	1	CAPSCREW, Hex Head, 5/16-18 x 1 G5	
42	1723267	1	BRACKET & PIN ASSEMBLY, Brake	
43	1729277	1	SPRING, Compression	
44	2176440	2	BUSHING, Nylon	
45	2927794	2	RING, E Retaining	
46	1727712	1	TRANSMISSION ASSEMBLY, Tuff Torq K46BF	

Footnotes:

Seat Deck & Fuel Tank Group

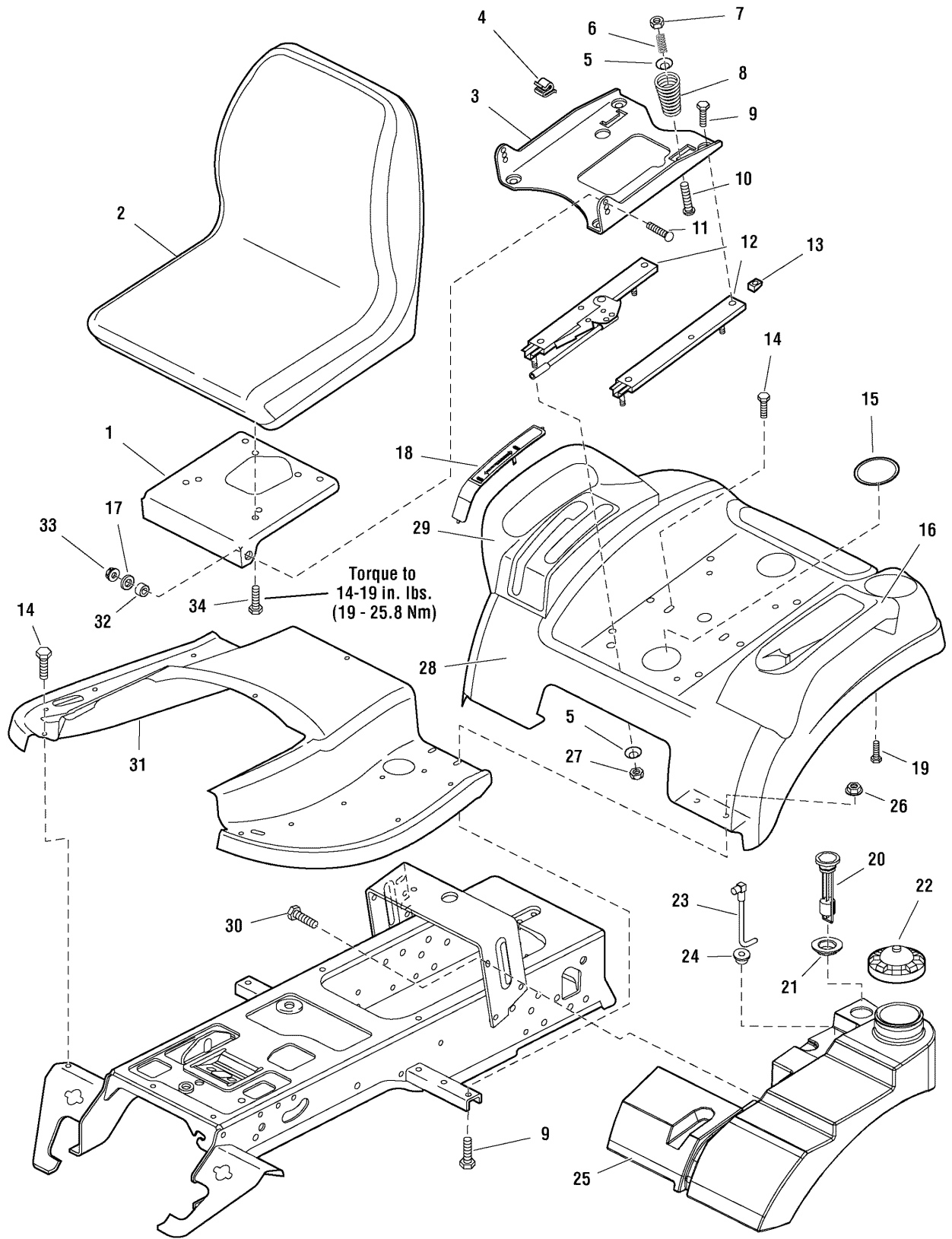

Seat Deck & Fuel Tank Group

Item	Part No	Qty	Description	Note
1	1722129A	1	BRACKET, Seat	
2	1725019	1	SEAT, 15" Back, Snapper Logo	
3	1722128A	1	SUPPORT, Seat	
4	2172434	1	CLIP, Wire	
5	1709256A	6	WASHER, Spring	
6	1714263	2	SPRING, Compression	
7	1919438	2	NUT, Hex Lock ESNA, 5/16-18	
8	1717051	2	SPRING, Compression	
9	1930591	8	CAPSCREW, Hex Head Whizlock, 5/16-18 x 3/4	
10	1931339	2	CARRIAGE BOLT, 5/16-18 x 2	
11	1931350	2	CARRIAGE BOLT, 3/8-16 x 1	
12	1722356	1	SLIDE, Seat, (2 Piece Set)	
13	1935255	4	NUT, Speed, 5/16-18	
14	1930601	4	CAPSCREW, Hex Head Taptite, 5/16-18 x 5/8	
15	1722309	1	PLUG, Hole Black	
16	1722109	1	POD, LH, w/Cup Holder	
17	1924940	2	WASHER	
18	1722313	1	COVER, Cruise, w/Symbols	
19	2960664	4	CAPSCREW, Hex Head Washer Dog Point, 1/4-20 x 7/8	
20	1722300	1	GAS GAUGE	
21	1722337	1	GROMMET	
22	1715917	1	CAP, Gas	
23	1722340	1	TUBE & ELBOW ASSEMBLY	
24	1654930	1	BUSHING	
25	1722652	1	TANK, Fuel	
26	1931277	4	NUT, Hex Whiz Lock, 5/16-18	
27	1960636	4	NUT, Hex KEPS, 5/16-18	
28	1727233D	1	DECK, Seat, Red	
29	1722108	1	POD, RH, W/2 Slots	
30	2934665	1	CAPSCREW, Hex Head Whizlock, 5/16-18 x 5/8	
31	1722105D	1	TUNNEL, Footrest, Red	
32	1663752	2	SPACER	
33	1930645	2	NUT, Hex Flange Lock, 3/8-16	
34	1960667	4	CAPSCREW, Hex Head Flange Lock, 5/16-18 x 3/4	

Footnotes:

Engine Group - 18 HP INTEK Single Cyl.

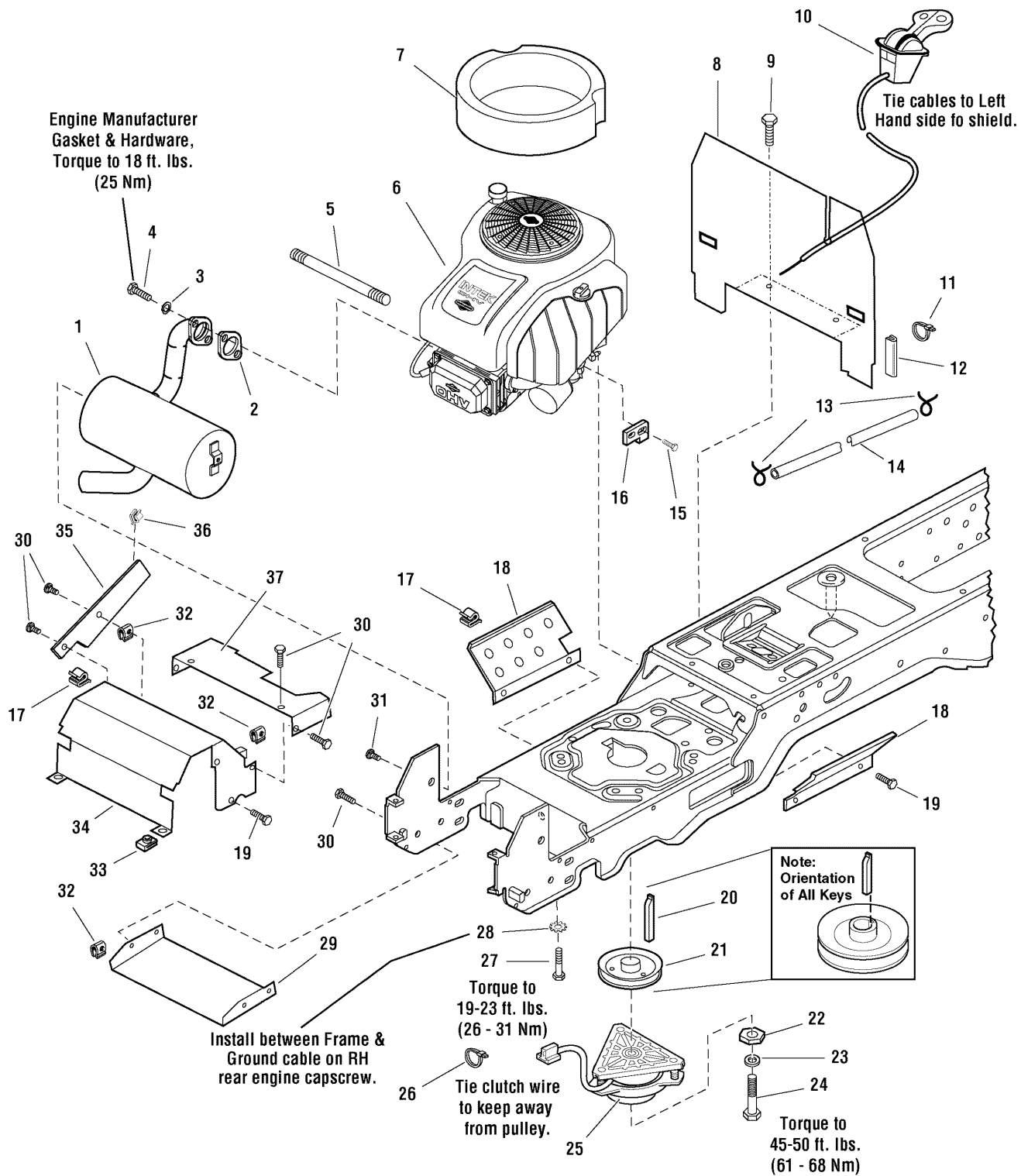

Engine Group - 18 HP INTEK Single Cyl.

Item	Part No	Qty	Description	Note
1	1723467	1	MUFFLER	
2		2	* GASKET	
3	1917356	4	LOCKWASHER, 5/16	
4	2960660	4	CAPSCREW, Socket Head, 5/16-18 x 7/8, G8	
5	1723165	1	HOSE, Oil Drain	
6		1	* ENGINE, 18HP Briggs & Stratton INTEK Single	(Mod. 31H777-0118-E1)
7	1722950	1	SEAL, Circle	
8	1722388A	1	BULKHEAD	
9	1925003	2	CAPSCREW, Hex Head Taptite, 1/4-20 x 1/2	
10	1724013	1	CONTROL, Throttle/Choke	
11	2925094	1	TIE	
12	1723894	1	EDGING, Rubber	
13	2960112	2	CLAMP, Hose Type E	
14	1723174	1	HOSE, 59" Long	
15	1726466	1	SCREW, Trox Head Taptite, #8-32 x 1/2	
16	1726465	1	PLATE, Limiter RPM	
17	2934683	2	CLIP, Wire	
18	1722392A	2	SHIELD	
19	1929000	3	SCREW, Hex Head Taptite, 1/4-20 x 3/8	
20	1720463	1	KEY	
21	1722288	1	PULLEY & HUB ASSEMBLY, 4-1/2 OD	
22	1708264	1	WASHER, Hex	
23	1918199	1	LOCKWASHER, 7/16	
24	1960648	1	CAPSCREW, Hex Head, 7/16-20 x 2-3/4	
25	1720532	1	CLUTCH, Electric, OGURA	
26	2932747	1	TIE	
27	2930598	4	CAPSCREW, Hex Head Taptite, 3/8-16 x 1-1/2	
28	2920427	1	LOCKWASHER, External Tooth, 3/8	
29	1722414A	1	SHIELD, Muffler Bottom	
30	1960295	6	CAPSCREW, Hex Head Flange Lock 1/4-20 x 5/8	
31	1924856	2	CAPSCREW, Hex Head Taptite, 5/16-18 x 1/2	
32	1960368	5	NUT, Speed, 1/4-20	
33	1935255	2	NUT, Speed, 5/16-18	
34	1722389A	1	DUCT, Muffler Top	
35	1723897A	1	GUARD, Manifold Pipe	
36	2172434	1	CLIP, Wire	
37	1722390A	1	DUCT, Muffler Extension	

Footnotes:

Note* See your local Briggs & Stratton distributor for parts and service.

Engine Group - 18 HP & 20 HP VANGUARD Twin Cyl.

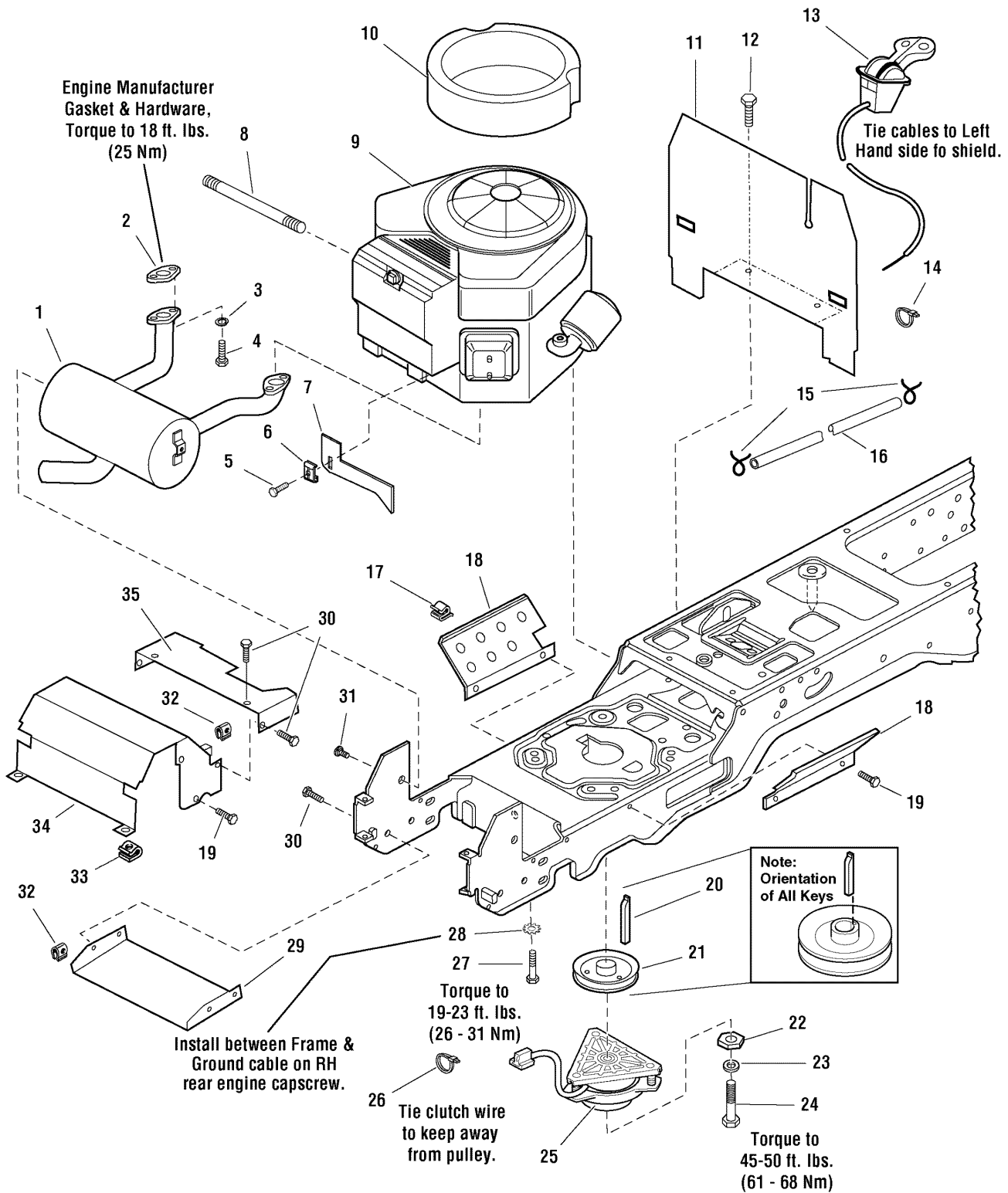

Engine Group - 18 HP & 20 HP VANGUARD Twin Cyl.

Item	Part No	Qty	Description	Note
1	1722625	1	MUFFLER	
2		1	* GASKET	
3	1917356	2	LOCKWASHER, 5/16	
4	2960660	2	CAPSCREW, Socket Head, 5/16-18 x 7/8, G8	
5	1728125	1	SCREW, Pan Head Trox, #10-32 x 5/8	
6	1728126	1	CLAMP, Throttle Cable	
7	1727696	1	PLATE, Limiter RPM	
8	1723165	1	HOSE, Oil Drain	
9		1	* ENGINE, 18HP Briggs & Stratton INTEK Twin	(Mod. 356777-0113-E1)
9		1	* ENGINE, 20HP Briggs & Stratton INTEK Twin	(Mod. 358777-0110-E1)
10	1722949	1	SEAL, Circle	
11	1722388A	1	BULKHEAD	
12	1925003	2	CAPSCREW, Hex Head Taptite, 1/4-20 x 1/2	
13	1727223	1	CONTROL, Throttle Double 39" Long w/Knobs	
14	2925094	1	TIE	
15	2960112	2	CLAMP, Hose Type E	
16	1723165	1	HOSE, 59" Long	
17	2934683	2	CLIP, Wire	
18	1722392A	2	SHIELD	
19	1929000	8	SCREW, Hex Head Taptite, 1/4-20 x 3/8	
20	1720463	1	KEY	
21	1722288	1	PULLEY & HUB ASSEMBLY, 4-1/2 OD	
22	1708264	1	WASHER, Hex	
23	1918199	1	LOCKWASHER, 7/16	
24	1960648	1	CAPSCREW, Hex Head, 7/16-20 x 2-3/4	
25	1720532	1	CLUTCH, Electric, OGURA	
26	2932747	1	TIE	
27	2930598	4	CAPSCREW, Hex Head Taptite, 3/8-16 x 1-1/2	
28	2920427	1	LOCKWASHER, External Tooth, 3/8	
29	1722414A	1	SHIELD, Muffler Bottom	
30	1960295	8	CAPSCREW, Hex Head Flange Lock, 1/4-20 x 5/8	
31	1924856	2	CAPSCREW, Hex Head Taptite, 5/16-18 x 1/2	
32	1960368	8	NUT, Speed, 1/4-20	
33	1935255	2	NUT, Speed, 5/16-18	
34	1722389A	1	DUCT, Muffler Top	
35	1722390A	1	DUCT, Muffler Extension	

Footnotes:

Note* See your local Briggs & Stratton distributor for parts and service.

40" Mower Deck - Belt, Idle Arm & Hitch

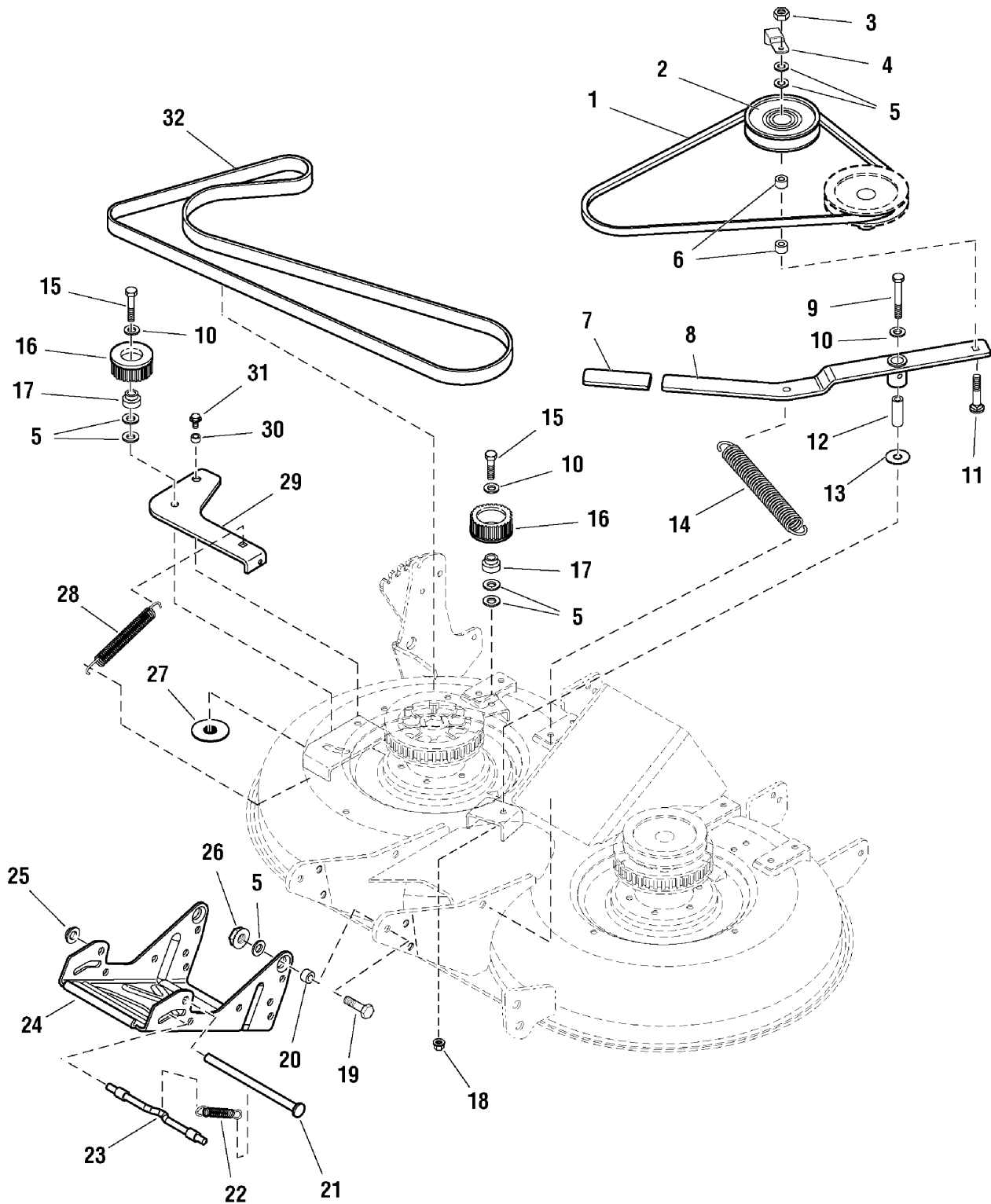

40" Mower Deck - Belt, Idle Arm & Hitch

Item	Part No	Qty	Description	Note
1	1725557	1	V-BELT	
2	2101096	1	PULLEY, 4-1/2 OD	
3	1919439	1	NUT, Hex Lock ESNA, 3/8-16	
4	1719842	1	STOP, Belt	
5	1924940	8	WASHER	
6	2157081	2	SPACER	
7	1719965	1	GRIP, Black	
8	1720444	1	IDLER ARM ASSEMBLY, w/Bushings	
9	1960614	1	CAPSCREW, Hex Head, 3/8-16 x 3, G8	
10	1922755	3	WASHER	
11	1960615	1	CARRIAGE BOLT, 3/8-16 x 2-1/2	
12	1657242	1	SPACER	
13	1933263	1	WASHER	
14	1715435	1	SPRING, Extension	
15	1923701	2	CAPSCREW, Hex Head, 3/8-16 x 2	
16	1724802	2	PULLEY, Idler	
17	1719221	2	HUB, Pulley	
18	1928352	2	NUT, Hex Flange Lock, 3/8-16	
19	1921968	2	CAPSCREW, Hex Head, 3/8-16 1-3/8	
20	2172329	2	SPACER	
21	1713578	1	ROD	
22	2156302	1	SPRING, Extension	
23	1715759	1	ROD	
24	1720044A	1	HITCH, Mower	
25	1960519	1	NUT, Push	
26	960681	2	NUT, Spiral Flange Toplock, 3/8-16	
27	1721425	1	WASHER & LOCK NUT ASSEMBLY, 3/8-16	
28	1674671	1	SPRING, Extension	
29	1726387A	1	ARM, Idler	
30	1666697	1	SPACER	
31	1930601	1	CAPSCREW, Hex Head Taptite, 5/16-18 x 5/8	
32	1724626	1	BELT, Timing	

Footnotes:

40" Mower Deck - Housing, Arbors & Blade

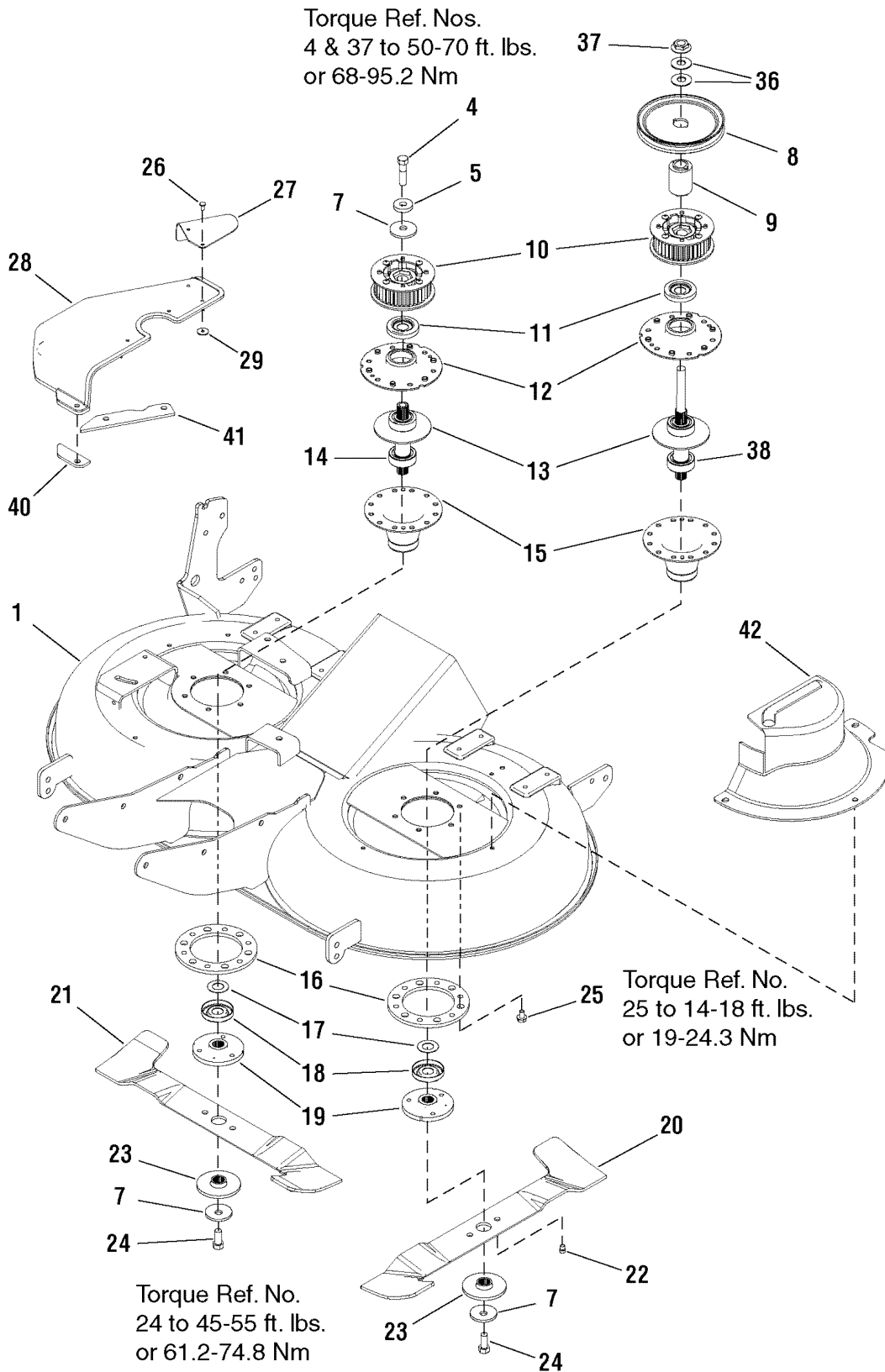

40" Mower Deck - Housing, Arbors & Blade

Item	Part No	Qty	Description	Note
1	1687322	1	HOUSING ASSEMBLY, 40" Red	
3	1664847	6	SCREW, Hex Washer Head Taptite 5/16-18 x 3/4	
4	2830584	1	CAPSCREW, Hex Head 7/16-14 x 2-3/4 G8	
5	1933263	1	WASHER, 7/16	
7	1656916	3	WASHER, Spring	
8	1732123	1	PULLEY	
9	1719862	1	HUB	
10	1732590	2	SPROCKET & FLANGE ASSEMBLY, Rivets/Screws 40"	
11	1657969	2	SHIELD, Bearing, Mower Arbor Upoer Heat Treated	
12	1655729A	2	HOUSING, Arbor Top	
13	1707335	2	GASKET, Foam	
14	1722396	1	ARBOR SHAFT & BEARINGS ASSEMBLY, 40"	
15	1703273A	2	HOUSING & FITTING ASSEMBLY, Lower	
16	1677274A	2	ADAPTER, Arbor	
17	1700230	2	WASHER, Shim	
18	1700229	2	SHIELD, Bearing	
19	1655777	2	ADAPTER, Blade	
20	1727477	1	BLADE, Mower L.H.	
21	1727478	1	BLADE, Mower R.H.	
22	1722258	2	PIN, Blade	
23	1722257	2	WASHER, Spline	
24	2827120	2	CAPSCREW, Hex Head 7/16-14 x 2-1/4 G8	
25	1960373	12	SCREW, Hex Washer Head Taptite 5/16-18 x 1	
26	1675044	2	RIVET, Pop	
27	1721132A	1	GUARD, Extension	
28	1724600	1	COVER, Arbor R.H.	
29	1960096	2	WASHER	
36	1713675	2	WASHER, Bellville	
37	1714419	1	NUT, Hex Flange 9/16-18	
38	1726826	1	ARBOR SHAFT & BEARINGS ASSEMBLY, 40"	
40	1732960A	1	SHIM, Cover L.H.	
41	1732961A	1	SHIM, Cover R.H.	
42	1732301	1	COVER, Arbor L.H.	

Footnotes:

40" Mower Deck - Height Adjustment & Roller Bar

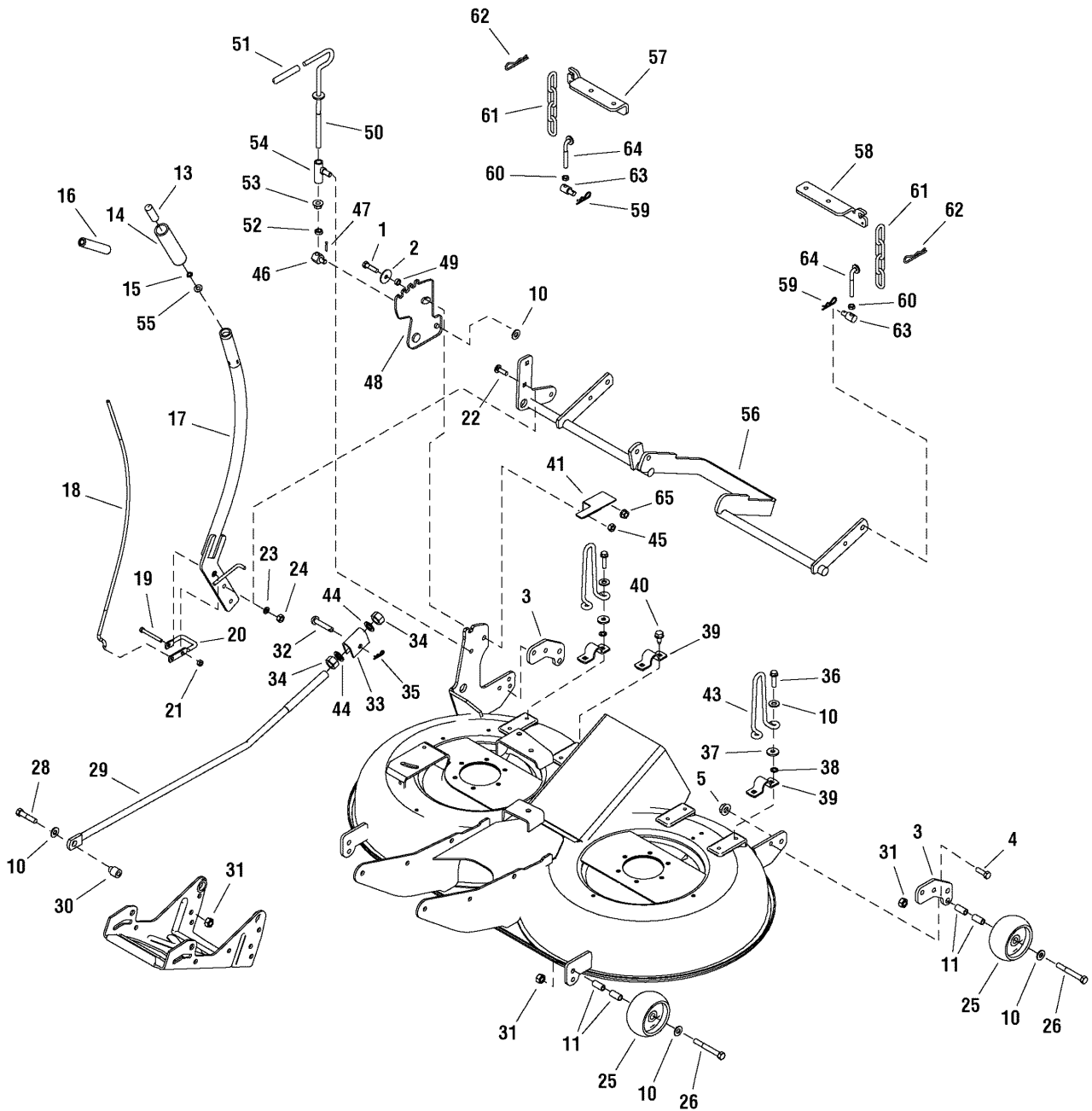

40" Mower Deck - Height Adjustment & Roller Bar

Item	Part No	Qty	Description	Note
1	1921977	1	CAPSCREW, Hex Head 5/16-18 x 1-1/4 G5	
2	1960044	1	WASHER, 5/16	
3	1733899A	2	BRACKET, Flat Mounting	
4	1921333	4	CAPSCREW, Hex Head 5/16-18 x 1 G5	
5	1960686	4	NUT, Hex Flange 5/16-18 Esna	
10	1924940	12	WASHER, 3/8	
11	1669585	8	SPACER	
13	1723124	1	BUTTON,	
14	1713995	1	GRIP	
15	1960674	1	NUT, Push Pal 1/4 Diameter Thread	
16	1723321	1	SPRING, Compression	
17	1732751A	1	HANDLE ASSEMBLY, Lift Curved	
18	1732754	1	ROD, Curved	
19	1921159	1	CAPSCREW, Hex Head 1/4-20 x 2-1/4 G5	
20	1720599	1	LATCH	
21	1920397	1	NUT, Hex Lock Esna Light 1/4-20	
22	1931335	2	CARRIAGE BOLT, 5/16-18 x 1 G5	
23	1917356	2	LOCKWASHER, Spring 5/16	
24	1917372	2	NUT, Hex 5/16-18	
25	1714760	4	WHEEL	
26	1923903	4	CAPSCREW, Hex Head 3/8-16 x 3 G5	
28	1922606	1	CAPSCREW, Hex Head 3/8-16 x 3/4 G8	
29	1722661	1	ROD	
30	1706644	1	SPACER, 3/8 x 3/4 x 15/16	
31	2860681	7	NUT, Hex Toplock Spirallock Flange 3/8-16	
32	2118053	1	PIN, Round Head Drilled 3/8 x 2	
33	1706645A	1	TRUNNION	
34	1915726	2	NUT, Hex 5/8-11	
35	1722460	1	PIN, Quick	
36	1931202	4	SCREW, Hex Washer Head Taptite 5/16-18 x 1-1/4	
37	1919381	4	WASHER, 5/16	
38	1933988	4	NUT, Push Pal 5/16 Diameter Thread	
39	1665374	3	STRAP	
40	1664847	2	SCREW, Hex Washer Head Taptite 5/16-18 x 3/4	
41	1720931A	1	BRACKET, Height of Cut	
42	1719846A	1	BAR	
43	1719929	2	STOP, Up	

Footnotes:

40" Mower Deck - Height Adjustment & Roller Bar

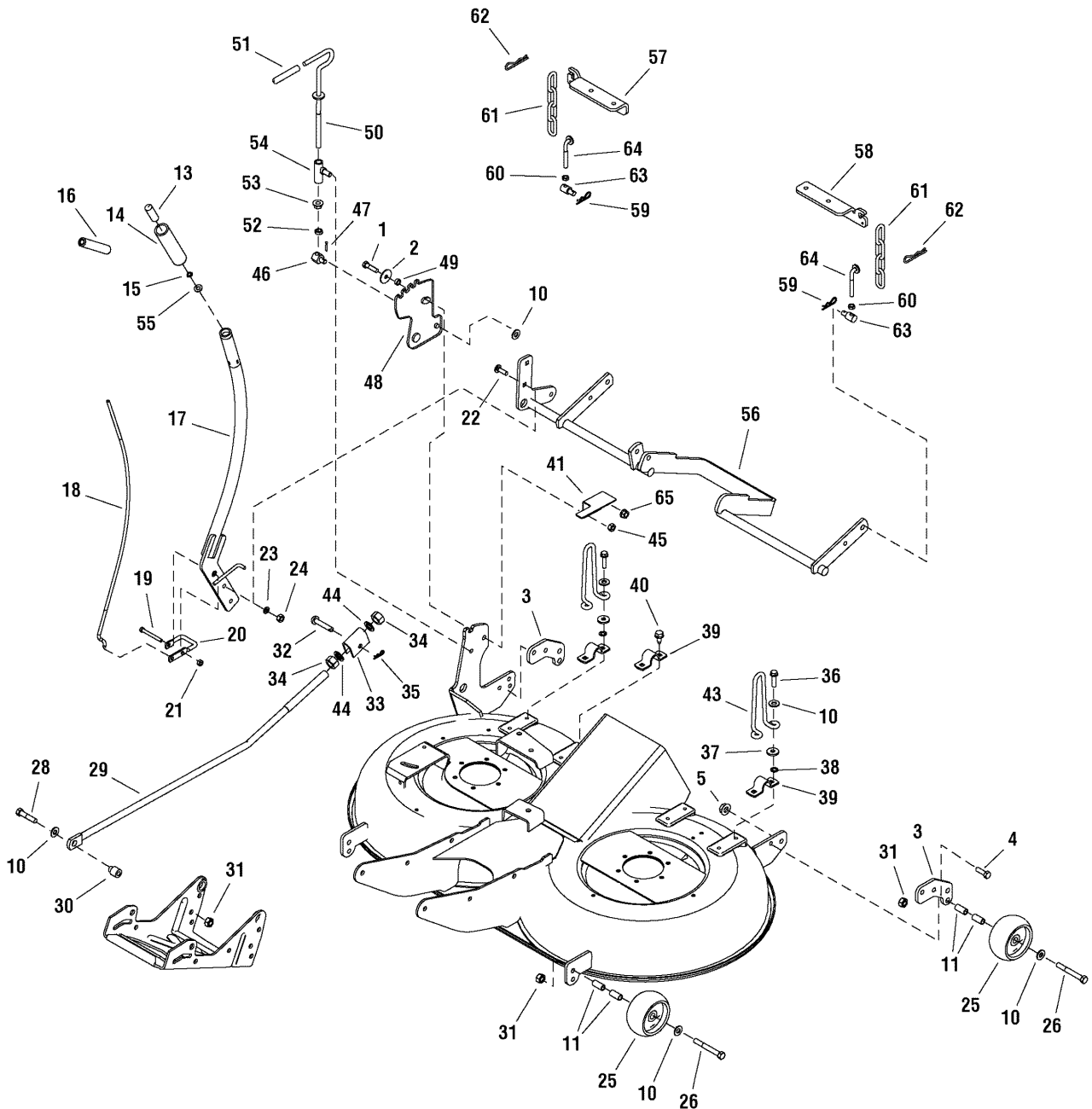

40" Mower Deck - Height Adjustment & Roller Bar

Item	Part No	Qty	Description	Note
44	1960703	2	WASHER, 5/8	
45	1919438	1	NUT, Hex Lock Esna Light 5/6-18	
46	2108512	1	PIVOT, 3/4 Hex & 3/8	
47	1918447	1	COTTER PIN,	
48	1723409A	1	BRACKET, Adjusting	
49	1666697	1	SPACER	
50	1720704	1	ROD & WASHER ASSEMBLY	
51	1651820	1	GRIP	
52	1917421	1	NUT, Hex Jam 3/8-16	
53	1960601	1	NUT, Hex Flange 3/8-16	
54	2108241	1	GUIDE ASSEMBLY, Rod	
55	1918265	1	WASHER, 5/16	
56	1733065A	1	SHAFT ASSEMBLY, Rocker 40"	
57	1727102A	1	HANGER, R.H.	
58	1727103A	1	HANGER, L.H.	
59	1960074	2	CLIP, Hair Pin	
60	1920161	2	NUT, Hex Jam 5/16-18	
61	1708088A	2	CHAIN, Link	
62	1960033	2	CLIP, Hair Pin	
63	1731382	2	TRUNNION	
64	1731384	2	ROD, Height Adjusting	
65	1930645	1	NUT, Hex Flange 3/8-16 Two-Way Lock	

Footnotes:

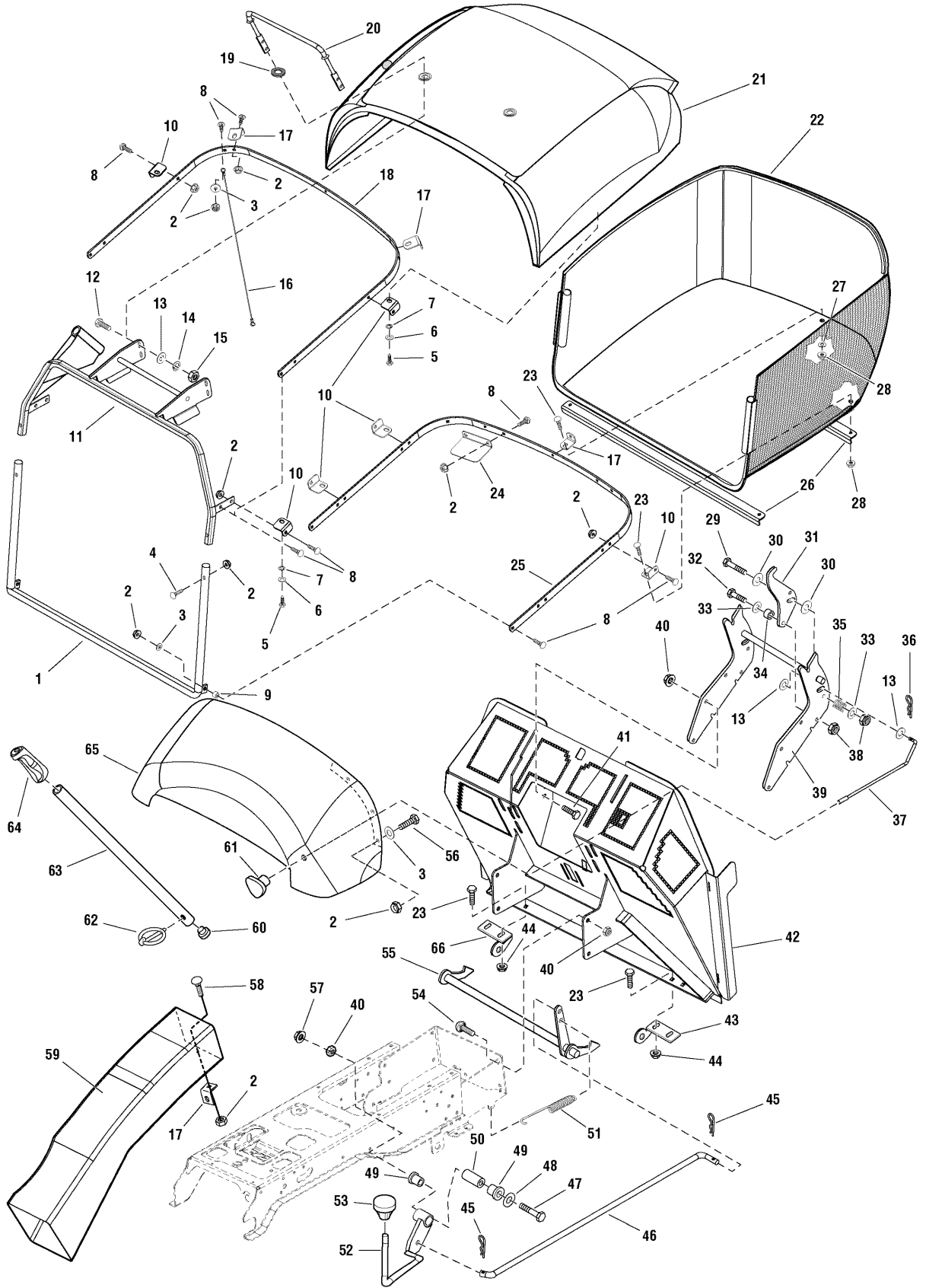

Hopper Group

Item	Part No	Qty	Description	Note
1	1727486A	1	ROD & TABS ASSEMBLY, Bagger Front	
2	1960685	22	NUT, Hex KEPS Conical Washer, 1/4-20	
3	1960353	8	WASHER, 1/4	
4	1931320	4	CARRIAGE BOLT, 1/4-20 x 1-1/4	
5	1921333	6	CAPSCREW, Hex Head, 5/16-18 x 1 G5	
6	1917356	6	LOCKWASHER, Spring 5/16	
7	1919326	6	WASHER, 5/16	
8	1931317	15	CARRIAGE BOLT, 1/4-20 x 3/4 G5	
9	1715654	2	SPACER	
10	1727674	6	CLIP, L 12GA	
11	1727420A	1	FRAME ASSEMBLY, Hopper	
12	1924009	4	CAPSCREW, Hex Head, 1/4-20 x 7/8 G5	
13	1921319	3	WASHER, 1/4	
14	1916964	4	LOCKWASHER, Spring 1/4	
15	1916622	4	NUT, Hex 1/4-20	
16	1727832	2	CABLE, Bagger, 17.72 Long	
17	1727676	4	CLIP, L 12GA	
18	1727671A	1	BAR, Bagger Top 7GA	
19	1724684	2	WASHER, 5/8	
20	1724399A	1	HANDLE, Hopper, 13.59 Long	
21	1727931	1	LID & SCREEN ASSEMBLY, Red	
22	1727423	1	BAG, Grass Black Cloth	
23	1931334	9	CARRIAGE BOLT, 5/16-18 x 7/8 G5	
24	1727520A	1	PLATE, Tube Stop Bagger 14GA	
25	1727670A	1	BAR, Bagger Bottom 7GA	
26	1727675A	2	BRACE, Angle	
27	1960044	1	WASHER, 5/16	
28	1960684	5	NUT, Hex KEPS Conical Washer, 5/16-18	
29	1921978	1	CAPSCREW, Hex Head, 5/16-18 x 2 G5	
30	1960044	2	WASHER, 5/16	
31	1724651A	1	LATCH, Release 10GA	
32	1921333	1	CAPSCREW, Hex Head, 5/16-18 x 1 G5	
33	1919326	2	WASHER, 5/16	
34	1666697	1	SPACER, Powdered Metal	
35	1714263	1	SPRING, Compression	
36	1923360	1	PIN, Cotter	

Footnotes:

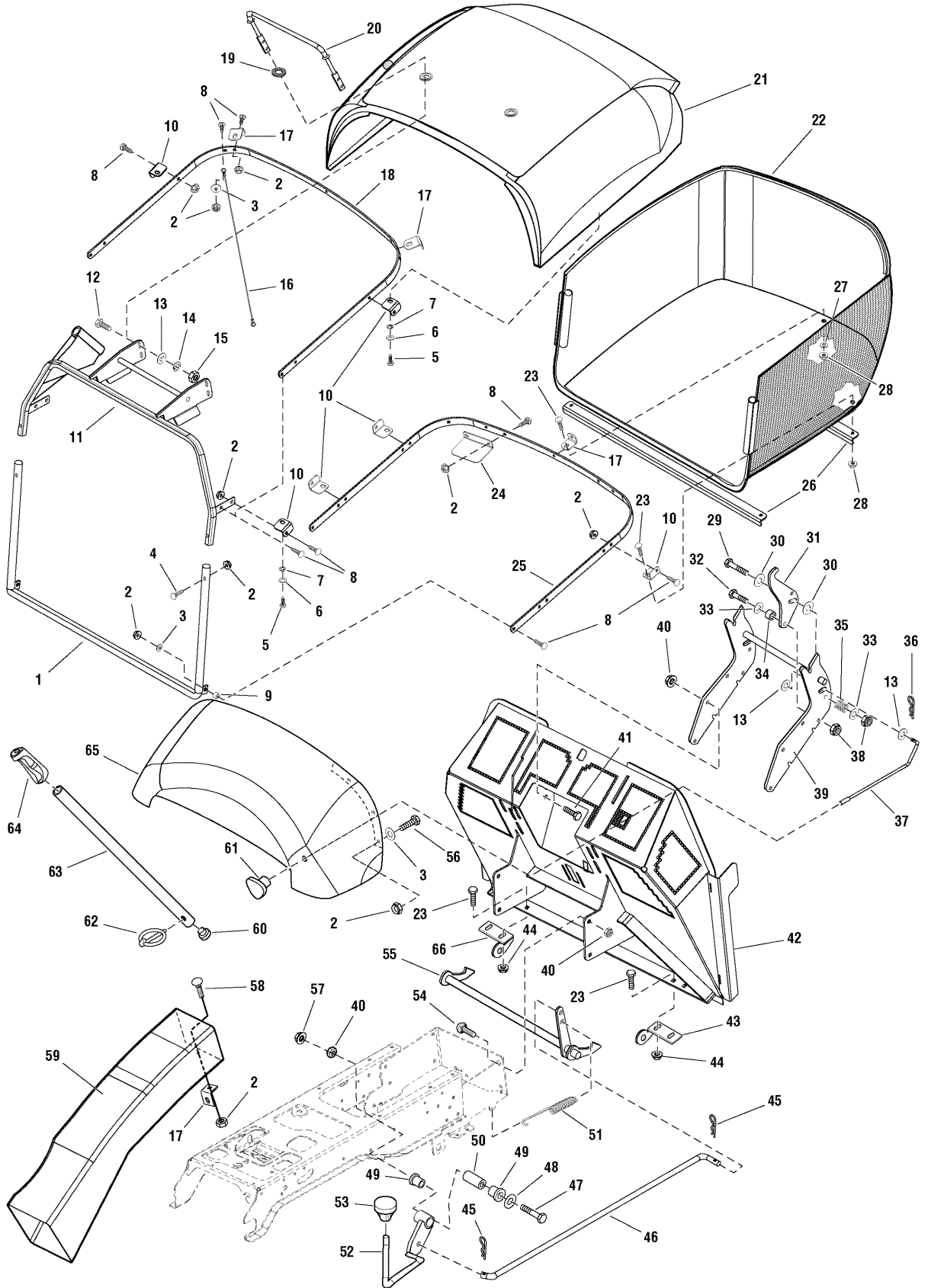

Hopper Group

Item	Part No	Qty	Description	Note
37	1724652	1	ROD, Foot Pedal Bagger Release, 11.66 Long, 2 Bends	
38	1919438	2	NUT, Hex Lock ESNA Light, 5/16-18 NC-3B	
39	1727580A	1	PIVOT ASSEMBLY, Latch	
40	1928352	5	NUT, Hex Flange Whiz Lock, 3/8-16 Large	
41	1921965	4	CAPSCREW, Hex Head, 3/8-16 x 3/4 G5	
42	1727419A	1	BACKPLATE ASSEMBLY	
43	1723182A	1	BRACKET, Latch LH, 7GA	
44	1931277	4	NUT, Hex Flange Whiz Lock, 5/16-18 Small	
45	1960074	2	CLIP, Hair Pin, Spring Wire	
46	1724458	1	ROD, 25.12 Long, 2 Bends	
47	1921973	1	CAPSCREW, Hex Head, 3/8-16 x 2-3/4 G5	
48	1924940	1	WASHER, 3/8	
49	1676148	2	BUSHING, Powdered Metal	
50	1669105A	1	SPACER, 1-1/2 Long, Hardened	
51	1718016	1	SPRING, Extension	
52	1725036	1	ROD & TUBE ASSEMBLY, Differential Lock Pedal	
53	1719940	1	KNOB, Hole 1/2, 1.37 Long	
54	1960268	4	CARRIAGE BOLT, 3/8-16 x 1-1/4 G5	
55	1724540	1	SHAFT & ARMS ASSEMBLY, Latch	
56	1960556	4	SCREW, Pan Head Torx Taptite, 1/4-20 x 3/4	
57	1930645	1	NUT, Hex Flange Two Way Lock, 3/8-16 GA	
58	1923341	1	CAPSCREW, Hex Head, 1/4-20 x 3/4 G5	
59	1727429	1	CHUTE, Discharge Black Poly	
60	1724553	1	CAPLUG, Black Poly, 3/4 Hole	
61	1713855	1	KNOB, Bagger Release	
62	1666969	1	PIN, Klik 5/164	
63	1727523A	1	HANDLE, Tube, 39.75 Long	
64	1723359	1	GRIP, Hopper Lift Rod	
65	1727406	1	TRANSITION, Hopper Black	
66	1723181A	1	BRACKET, Latch RH, 7GA	

Footnotes:

Deflector Group

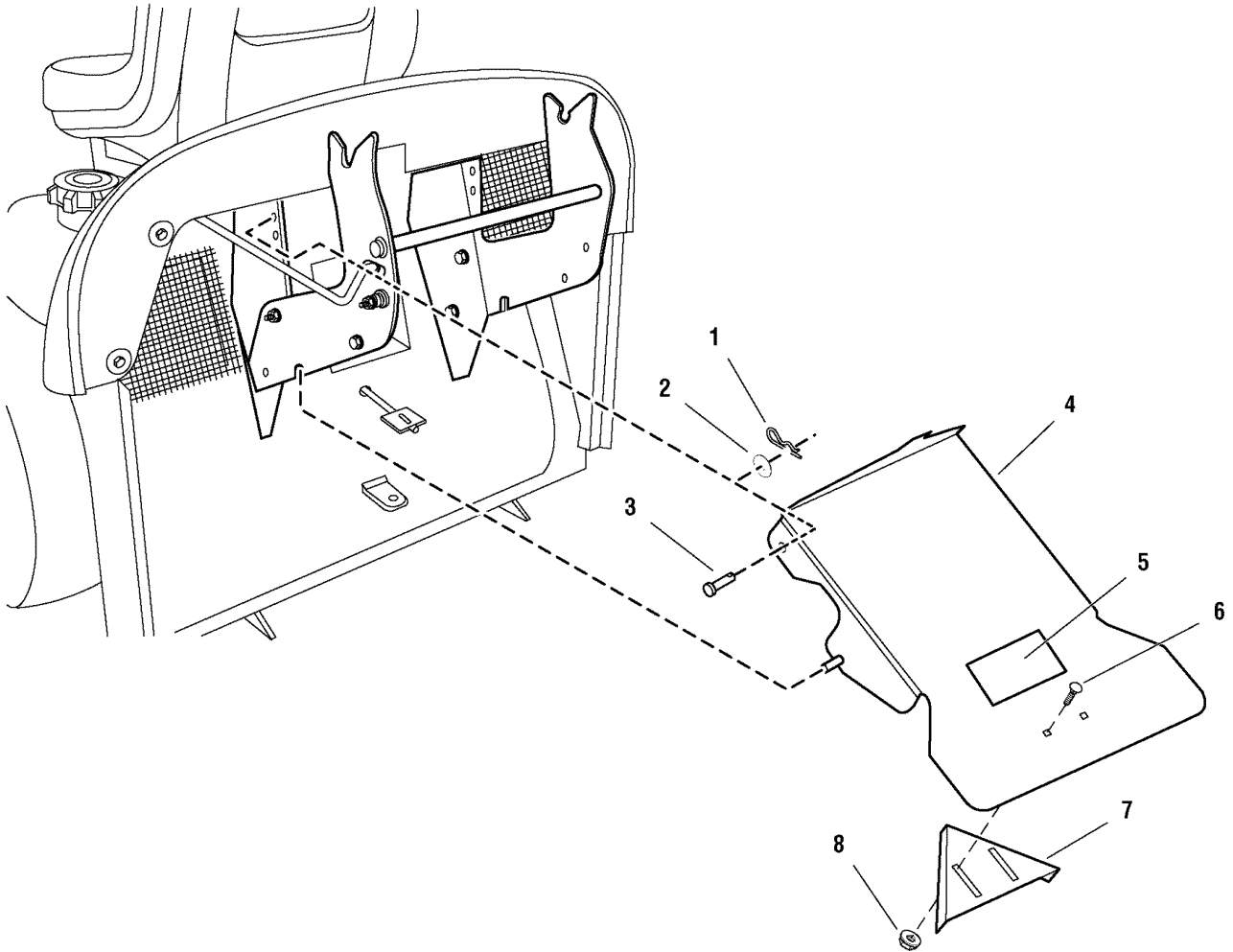

Deflector Group

Item	Part No	Qty	Description	Note
1	1960074	2	CLIP, Hair Pin	
2	1919381	2	WASHER, 5/16	
3	1723683	2	PIN, Clevis	
4	1724935A	1	DEFLECTOR & PINS ASSEMBLY	
5	1720391	1	DECAL, Danger Operating without Catcher	
6	1960252	2	CARRIAGE BOLT, 1/4-20 x 5/8 G5	
7	1724864A	1	DEFLECTOR, 16GA	
8	1960685	2	NUT, Hex KEPS Conical Washer, 1/4-20	

Footnotes:

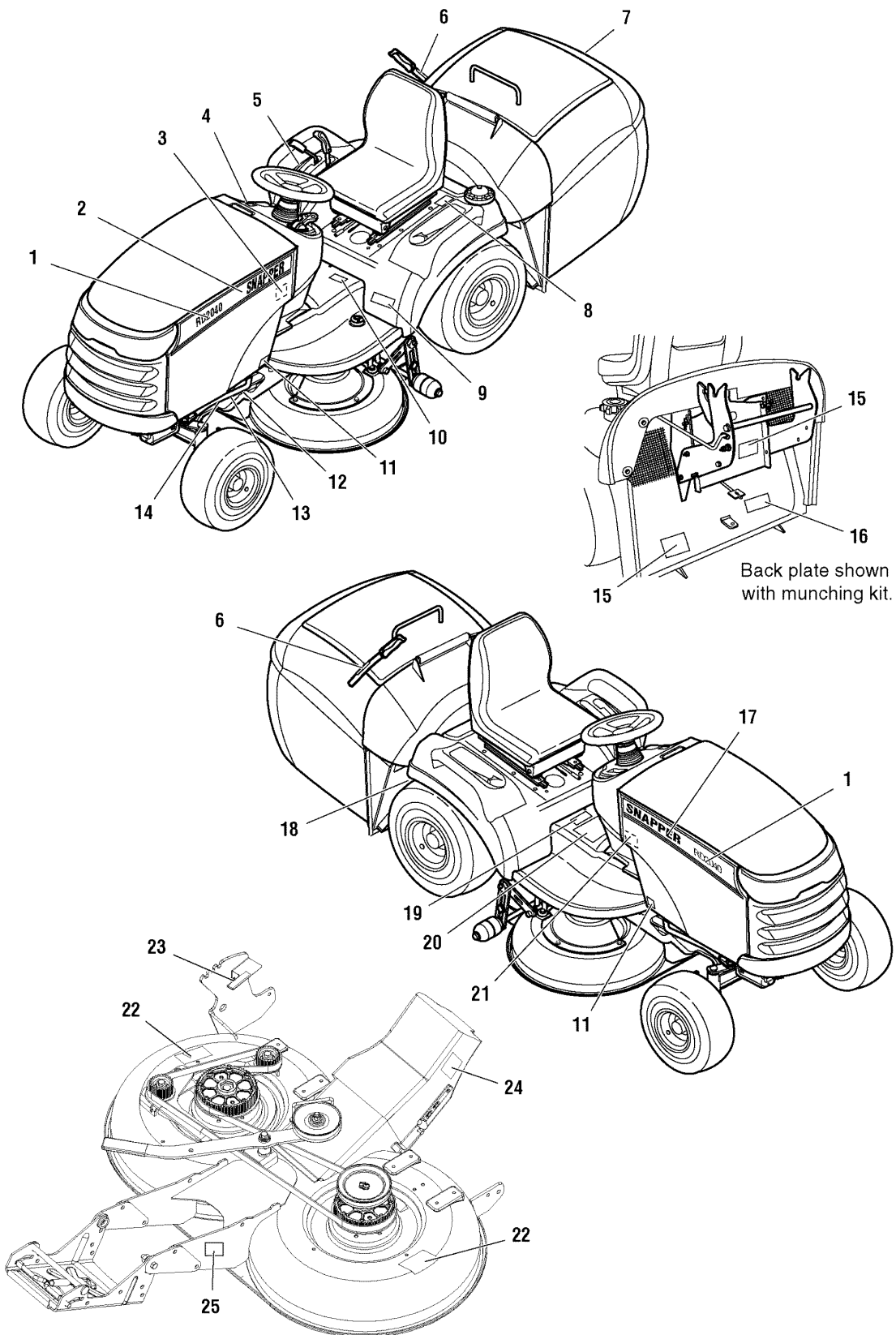

Decals Group

Item	Part No	Qty	Description	Note
1	1725240	2	DECAL, RD1840	
2	1725065	1	DECAL, Hood Stripe, Snapper, LH	
3	1727713	1	DECAL, Belt & Blade	
4	1722806	1	DECAL, Ignition Switch	
5	1723713	1	DECAL, Crusie / Lift	
6	1723310	1	DECAL, Hopper Lever	
7	1725061	1	DECAL, Snapper	
8	1724680	1	DECAL, Latch Release	
9	1727714	1	DECAL, Baron XL	
10	1723317	1	DECAL, Hopper Pedal	
11	1723296	2	DECAL, Protective, Clear	
12		1	* DECAL, Patent	
13		1	* DECAL, Serial Number, Tractor	
14		2	* DECAL, Decible Power Mass, Export Only	
15	1720391	2	DECAL, Danger Operating W/O Catcher	
16	1721141	1	DECAL, Drawbar Max Load	
17	1725066	1	DECAL, Hood Stripe, Snapper, RH	
18	1723425	1	DECAL, Transmission Release Valve	
19	1720390	1	DECAL, Danger Catcher Open	
20	1723175	1	DECAL, Warning/Danger Icons, Tunnel	
21	1725072	1	DECAL, Touch Up Paint	
22	1720389	2	DECAL, Danger Rotating Blade, Export Only	
23	1723470	1	DECAL, Height Of Cut	
24	1721107	1	DECAL, Danger, Discharge Tube	
25		1	* DECAL, Serial Number, Mower Deck	

Footnotes:

Note: * Not a Service Part

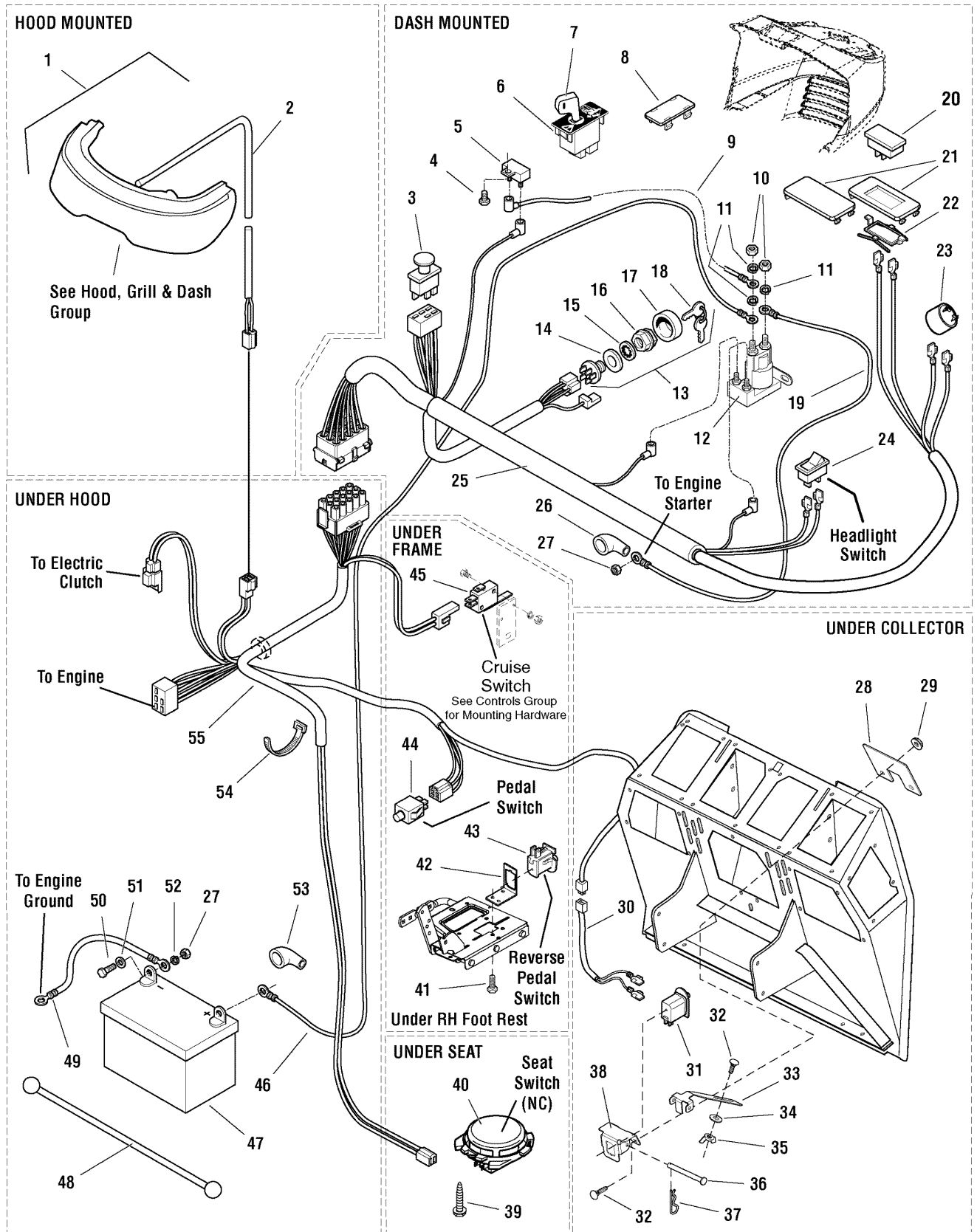

Electrical Group

Item	Part No	Qty	Description	Note
1	1721810	1	HEADLIGHT ASSEMBLY, 4 Bulb	
2	1722669	1	HARNESS, Headlight	
3	1722887	1	SWITCH, PTO Push/Pull w/Symbols	
4	1921959	1	CAPSCREW, Hex Head, 1/4 x 5/8	
5	1722739	1	SOLENOID	
6	1726556	1	MODULE, RMO	(Includes Ref. No. 7)
7	1726557	1	KEY, RMO Module Plastic	
7	1727185	1	KEY, w/Hang Tag for RMO Module	
8	1722611	1	PLUG, Hole Black	
9	1665237	1	WIRE, 12GA 8 Long Red	
10	2920426	3	LOCKWASHER, External Tooth 5/16	
11	1665238	1	BREAKER, Circuit 12VOLT 20AMPS w/Tabs	
12	2916622	3	NUT, Hex, 1/4-20 NC-2B	
13	1716061	1	SWITCH ASSEMBLY, Ingition, 6 Pin Indak	(Includes Ref. Nos. 1)
14	2101025	1	WASHER, 5/8	
15	1960547	1	LOCKWASHER, Internal Tooth, 5/8	
16	1717549	1	NUT, Hex Flange, 5/8-32 Ignition Switch	
17	1717550	1	COVER, Ignition Switch, Black	
18	1717163	1	KEYS, Ignition Set of 2	
19	1721830	1	CABLE, # 6 x 25 Long Red, 2 Ring Terminals	
20	1725523	1	METER, Hour Digital w/Oil & Lube Alarms	
21	1725524	1	PLUG, Dash, Hour Meter	
21	1725698	1	PLUG, Dash, No Hour Meter Hole	
22	1725835	1	CLIP, Hour Meter, Holds In Dash	
23	1720117	1	BUZZER, Pulse, Grass Bag Full	
24	1716951	1	SWITCH, Headlights, 2 Terminal	
25	1726890	1	HARNESS, Wiring Upper	
26	1677296	1	BOOT, Insulator, Battery Terminal	
27	920263	2	NUT, Hex, 5/16-24 NF-2B	
28	1727776A	1	DEFLECTOR, Switch 14GA	
29	1960685	2	NUT, Hex KEPS Conical Washer, 1/4-20	
30	1723954	1	HARNESS, Wiring Rear	
31	1720411	1	SWITCH, Push Button w/Boot, Bagger	
32	1960252	3	CARRIAGE BOLT, 1/4-20 x 5/8 G5	
33	1727428	1	PIVOT, Actuator 14GA, E-Coat	
34	1960103	1	WASHER, 3/8	
35	960293	1	NUT, Wing Lock, 1/4-20	

Footnotes:

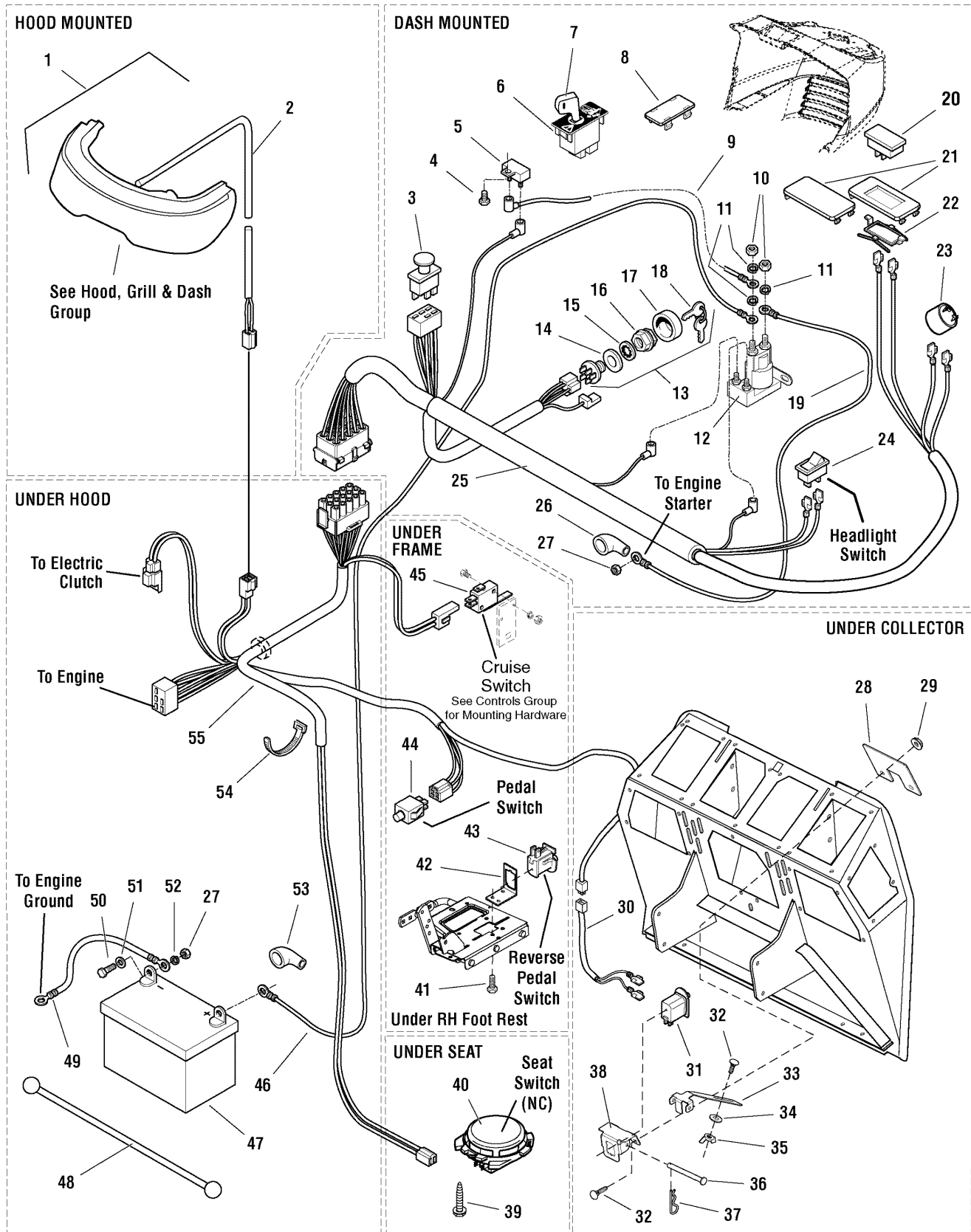

Electrical Group

Item	Part No	Qty	Description	Note
36	1960607	1	PIN, Clevis	
37	1960221	1	CLIP, Hair Pin	
38	1727427	1	SUPPORT, Actuator 14GA, E-Coat	
39	1960536	2	SCREW, Hex Washer Head Plastite, 1/4 x 1/2	
40	1716368	1	SWITCH, Operator Presents, Seat	
41	1929000	1	SCREW, Hex Washer Head Taptite, 1/4-20 x 3/8	
42	1726810A	1	BRACKET, Switch Mounting, RMO	
43	1704379	2	SWITCH, Push Button, Reverse Pedal	
44	1723507	1	SWITCH, Push Button, Foot Pedal	
45	1717050	1	SWITCH, Push Button, Cruise Control	
46	1603618	1	CABLE, # 6 x 9 Long, 2 Ring Terminals	
47	1685215	1	BATTERY, 12VOLT 6CELL 230AMPS CCA	
48	1722009	1	STRAP, Battery 14 Long, Black Rubber	
49	1713163	1	CABLE, # 6 x 26 Long Black, 2 Ring Terminals	
50	2923341	2	CAPSCREW, Hex Head, 1/4-20 x 3/4 G5	
51	2921319	2	WASHER, 1/4	
52	2916964	2	LOCKWASHER, Spring 1/4	
53	1713535	1	BOOT, Insulator Red, Cable Terminal	
54	2925094	4	TIE, Self Locking, 7-5/16	
55	1726889	1	HARNESS, Wiring Lower	

Footnotes:

Parts Manual for

SNAPPER[®]

YARD TRACTOR ELECTRIC CLUTCH HYDRO DRIVE RMO & ACS "RD" SERIES 0

IT IS THE POLICY OF BRIGGS & STRATTON CORP TO IMPROVE ITS PRODUCTS WHENEVER IT IS POSSIBLE AND PRACTICAL TO DO SO. WE RESERVE THE RIGHT TO MAKE CHANGES OR ADD IMPROVEMENTS AT ANY TIME WITHOUT INCURRING ANY OBLIGATION TO MAKE SUCH CHANGES ON PRODUCTS

SNAPPER[®] McDonough, GA, 30253 U.S.A.