

# Safety Instructions & Operator's Manual for **SNAPPER**<sup>®</sup>

## REAR ENGINE RIDING MOWER SERIES 19

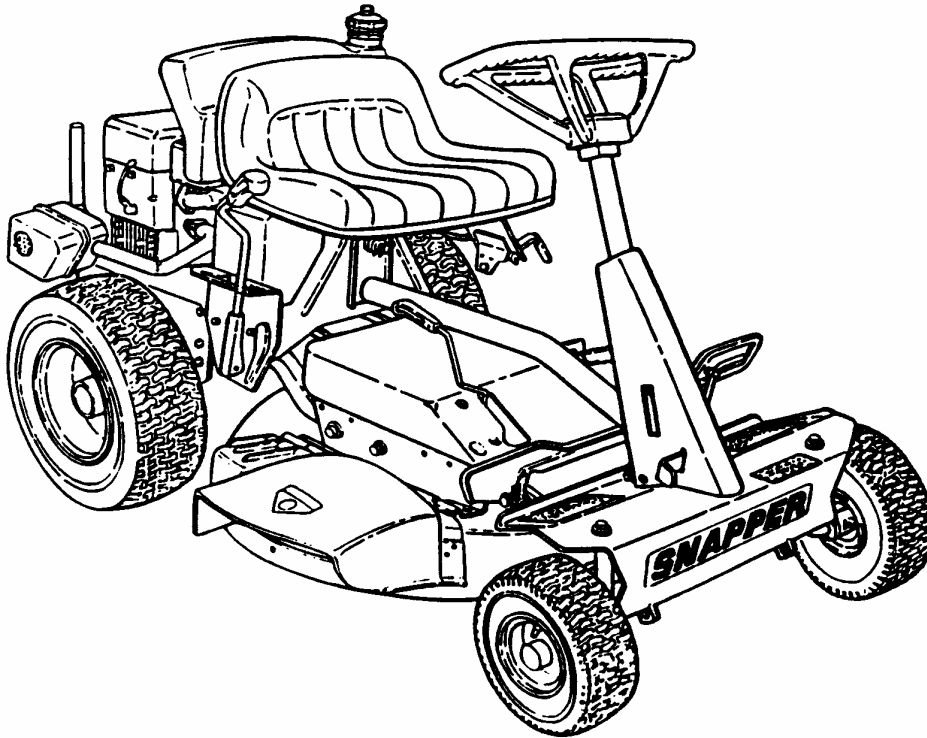

MODEL
M250819BE
M280919B
M281019BE
M300919B
M301019BE

### MODEL NUMBER EXPLANATION

**M 28 10 19 B E**

MIDDLE MARKET  
CUTTING WIDTH  
ENGINE HP

ENGINE OPTIONS  
ENGINE TYPE  
SERIES DESIGNATION

M - Middle Market	25 - 25" Cutting Deck 28 - 28" Cutting Deck 30 - 30" Cutting Deck	08 - 8.0 HP Engine 09 - 9.0 HP Engine 10 - 10.0 HP Engine	19 - Series Designation	B - Briggs Engine	E - Electric Start
-------------------	---	---	-------------------------	-------------------	--------------------

Thank you for buying a SNAPPER Product! Before operating your machine, read this manual carefully and pay particular attention to the "IMPORTANT SAFETY INSTRUCTIONS" on Pages 2 & 3. Remember that all power equipment can be dangerous if used improperly. Also keep in mind that SAFETY requires careful use in accordance with the operating instructions and common sense!

**SNAPPER**<sup>®</sup> McDonough, GA., 30253 U.S.A.



## IMPORTANT SAFETY INSTRUCTIONS



**WARNING:** This powerful cutting machine is capable of amputating hands and feet and can throw objects that can cause injury and damage! Failure to comply with the following SAFETY instructions could result in serious injury or death to the operator or other persons. The owner of the machine must understand these instructions and must allow only persons who understand these instructions to operate machine. Each person operating the machine must be of sound mind and body and must not be under the influence of any substance, which might impair vision, dexterity or judgment. If you have any questions pertaining to your machine which your dealer cannot answer to your satisfaction, call or write the Customer Service Department at SNAPPER, McDonough, Georgia 30253. Phone: (1-800-935-2967).

### PROTECTION FOR CHILDREN

Tragic accidents can occur if the operator is not alert to the presence of children. Children are often attracted to the machine and the mowing activity. Never assume that children will remain where you last saw them.

1. KEEP children out of the mowing area and under the watchful care of a responsible adult.
2. DO NOT allow children in yard when machine is operated (even with the blade OFF).
3. DO NOT allow children or others to ride on machine or on attachments (even with the blades OFF). They may fall and be seriously injured.
4. DO NOT allow pre-teenage children to operate machine.
5. ALLOW only responsible adults & teenagers with mature judgment under close adult supervision to operate machine.
6. DO NOT operate blades in reverse. STOP BLADES. LOOK and SEE behind and down for children, pets and hazards before and while backing.
7. USE EXTRA CARE when approaching blind corners, shrubs, trees, or other objects that may obscure vision.

### PROTECTION AGAINST TIPOVERS

Slopes are a major factor related to loss-of-control and tip-over accidents, which can result in severe injury or death. All slopes require extra CAUTION. If you cannot back up the slope or if you feel uneasy on the slope, DO NOT mow it. Use extra care with grass catchers or other attachments; these affect the handling and the stability of the machine.

1. DO NOT operate machine on slopes exceeding 15 degrees (27% grade).
2. Exercise EXTREME CAUTION on slopes above 10 degrees (18% grade). Turn blades OFF when traveling uphill. Use a slow speed and avoid sudden or sharp turns.
3. DO NOT operate machine back and forth across face of slopes. Operate up and down. Practice on slopes with blades off.
4. AVOID uphill starts. If machine stops going uphill or tires lose traction, turn blades OFF and back slowly down the slope.

### PROTECTION AGAINST TIPOVERS

(Continued From Previous Column)

5. STAY ALERT for holes and other hidden hazards. Tall grass can hide obstacles. Keep away from ditches, washouts, culverts, fences and protruding objects.
6. KEEP A SAFE DISTANCE (at least 3 feet) away from edge of ditches and other drop offs. The machine could turn over if an edge caves in.
7. Always begin forward motion slowly and with caution.
8. Use weights or a weighted load carrier in accordance with instructions supplied with a grass catcher. DO NOT operate machine on slopes exceeding 10 degrees (18% grade) when equipped with grass catcher.
9. DO NOT put your foot on the ground to try to stabilize the machine.
10. DO NOT operate machine on wet grass. Reduced traction could cause sliding.
11. DO NOT operate machine under any condition where traction, steering or stability is doubtful.

### PREPARATION

1. Read, understand, and follow instructions and warnings in this manual and on the machine, engine and attachments. Know the controls and the proper use of the machine before starting.
2. Only mature, responsible persons shall operate the machine and only after proper instruction.
3. Data indicates that operators age 60 and above, are involved in a large percentage of mower-related injuries. These operators should evaluate their ability to operate the mower safely enough to protect themselves and others from serious injury.
4. Handle fuel with extra care. Fuels are flammable and vapors are explosive. Use only an approved fuel container. DO NOT remove fuel cap or add fuel with engine running. Add fuel outdoors only with engine stopped and cool. Clean spilled fuel from machine. DO NOT smoke.
5. Practice operation of machine with BLADES OFF to learn controls and develop skills.
6. Check the area to be mowed and remove all objects such as toys, wire, rocks, limbs and other objects that could cause injury if thrown by blade or interfere with mowing.



## IMPORTANT SAFETY INSTRUCTIONS



### PREPARATION

(Continued From Previous Page)

7. Keep people and pets out of mowing area. Immediately STOP blades, STOP engine, and STOP machine if anyone enters the area.
8. Check shields, deflectors, switches, blade controls and other safety devices frequently for proper operation and location.
9. Make sure all safety decals are clearly legible. Replace if damaged.
10. Protect yourself when mowing and wear safety glasses, long pants and substantial footwear.
11. Know how to STOP blades and engine quickly in preparation for emergencies.
12. Use extra care when loading or unloading the machine into a trailer or truck.
13. Check grass catcher components frequently for signs of wear or deterioration and replace as needed to prevent injury from thrown objects going through weak or worn spots.

### OPERATION

1. Mount and dismount machine from left side.
2. Start engine from operator's seat, if possible. Make sure blades are OFF and parking brake is set.
3. DO NOT leave machine with engine running. STOP engine, STOP blades, SET brake, and Remove key before leaving operators position of any reason.
4. DO NOT operate machine unless properly seated with feet on feet rests or pedal(s).
5. STOP BLADES and ENGINE and make sure blades have stopped before removing grass catcher or unclogging mower to prevent loss of fingers or hand.
6. Blades must be OFF except when cutting grass. Set blades in highest position when mowing over rough ground.
7. Keep hands and feet away from rotating blades underneath deck. DO NOT place foot on ground while BLADES are ON or machine is in motion.
8. DO NOT operate machine without entire grass catcher or guards in place. DO NOT point discharge at people, passing cars, windows or doors.
9. Slow down before turning.
10. Watch out for traffic when near or crossing roadways.
11. STOP engine immediately after striking an obstruction. Inspect machine and repair damage before resuming operation.
12. Operate machine only in daylight or with good artificial light.
13. Move joystick (if equipped) SLOWLY to maintain control during speed and directional changes.

### OPERATION

(Continued From Previous Column)

14. Exercise CAUTION when pulling loads. Limit loads to those you can safely control and attach loads to hitch plate as specified with SNAPPER attachment instructions.
15. DO NOT operate engine in enclosed areas. Engine exhaust gases contain carbon monoxide, a deadly poison.

### MAINTENANCE

1. DO NOT store machine or fuel container inside where fumes may reach an open flame, spark or pilot light such as in a water heater, furnace, clothes dryer or other gas appliance. Allow engine to cool before storing machine in an enclosure. Store fuel container out of the reach of children in a well ventilated, unoccupied building.
2. Keep engine free of grass, leaves or excess grease to reduce fire hazard and engine overheating.
3. When draining fuel tank, drain fuel into an approved container outdoors and away from open flame.
4. Check brakes frequently; adjust, repair or replace as needed.
5. Keep all bolts, nuts and screws properly tight. Check that all cotter pins are in proper position.
6. Always provide adequate ventilation when running engine. Exhaust gases contain carbon monoxide, an odorless and deadly poison.
7. Disconnect negative (black) cable from battery before performing maintenance or service. Cranking engine could cause injury.
8. DO NOT work under machine without safety blocks.
9. Service engine and make adjustments only when engine is stopped. Remove spark plug wire(s) from spark plug(s) and secure wire(s) away from spark plug(s).
10. DO NOT change engine governor speed settings or overspeed engine.
11. Lubricate machine at intervals specified in manual to prevent controls from binding.
12. Mower blades are sharp and can cut. Wrap the blades or wear heavy leather gloves and use CAUTION when handling them.
13. DO NOT test for spark by grounding spark plug next to spark plug hole; spark plug could ignite gas exiting engine.
14. Have machine serviced by an authorized SNAPPER dealer at least once a year and have the dealer install any new safety devices.
15. Use only genuine SNAPPER replacement parts to assure that original standards are maintained.

# TABLE OF CONTENTS

IMPORTANT SAFETY INSTRUCTIONS.....	2-3
TABLE OF CONTENTS.....	4
SECTION 1 - FAMILIARIZATION.....	5
SECTION 2 - OPERATING INSTRUCTIONS.....	6-11
Pre-start Checklist.....	6
Operator's Seat Adjustment.....	6
Starting & Stopping Engine, Blades & Wheel Drive.....	7-10
Starting & Stopping Mower Blades.....	9-10
Starting & Stopping Wheel Drive.....	9-10
Parking Brake.....	11
Cutting Height Adjustment.....	11
SECTION 3 - MAINTENANCE INSTRUCTIONS.....	12-17
Service – After First 5 Hours.....	12
Change Engine Oil.....	12
Service Engine Air Cleaner.....	12
Check Mower Blade.....	12
Check Blade Drive Belt.....	13
Blade Brake.....	13
Service Brake / Park Brake.....	13
Check Interlock System.....	13
Lubrication – Grease Fittings.....	14
Service - Every 25 Operating Hours.....	14-15
Battery Fluid Level.....	14
Mower Deck Levelness.....	14
Clean Mower Deck.....	14
Mower Blade Spindle - Lubrication.....	14
Mower Deck Linkage – Lubrication.....	14
Front Wheel Bearing - Lubrication.....	14-15
Rear Axle Bearing – Lubrication.....	15
Differential / Chain Case - Lubrication.....	15
Service – Annually.....	16
Engine.....	16
Fuel Filter.....	16
Every Two Years.....	16
Storage - Out of Season.....	16
Removing Fuel Tank.....	16
SECTION 4- ADJUSTMENTS AND REPAIR.....	17-25
Engine Adjustments & Repair.....	17
Mower Deck & Component Adjustments.....	17
Mower Drive Belt Adjustment.....	17
Blade Brake Adjustment.....	18
Mower Deck Adjustment (Side to Side Levelness).....	18-19
Mower Deck Adjustment (Front to Rear Levelness).....	19
Rear Engine Rider Drive Components.....	20
Wheel Brake Adjustment.....	20
Mower Blade Replacement.....	21
Blade Sharpening.....	21
Blade Drive Belt Removal/Replacement.....	22
Battery Removal, Replacement, Service.....	23-25
ACCESSORIES.....	25
TROUBLESHOOTING.....	26-27
MAINTENANCE SCHEDULE.....	28
MAINTENANCE/REPLACEMENT PARTS.....	29
WARRANTY.....	30
PRIMARY MAINTENANCE.....	31-34

# Section 1 - FAMILIARIZATION

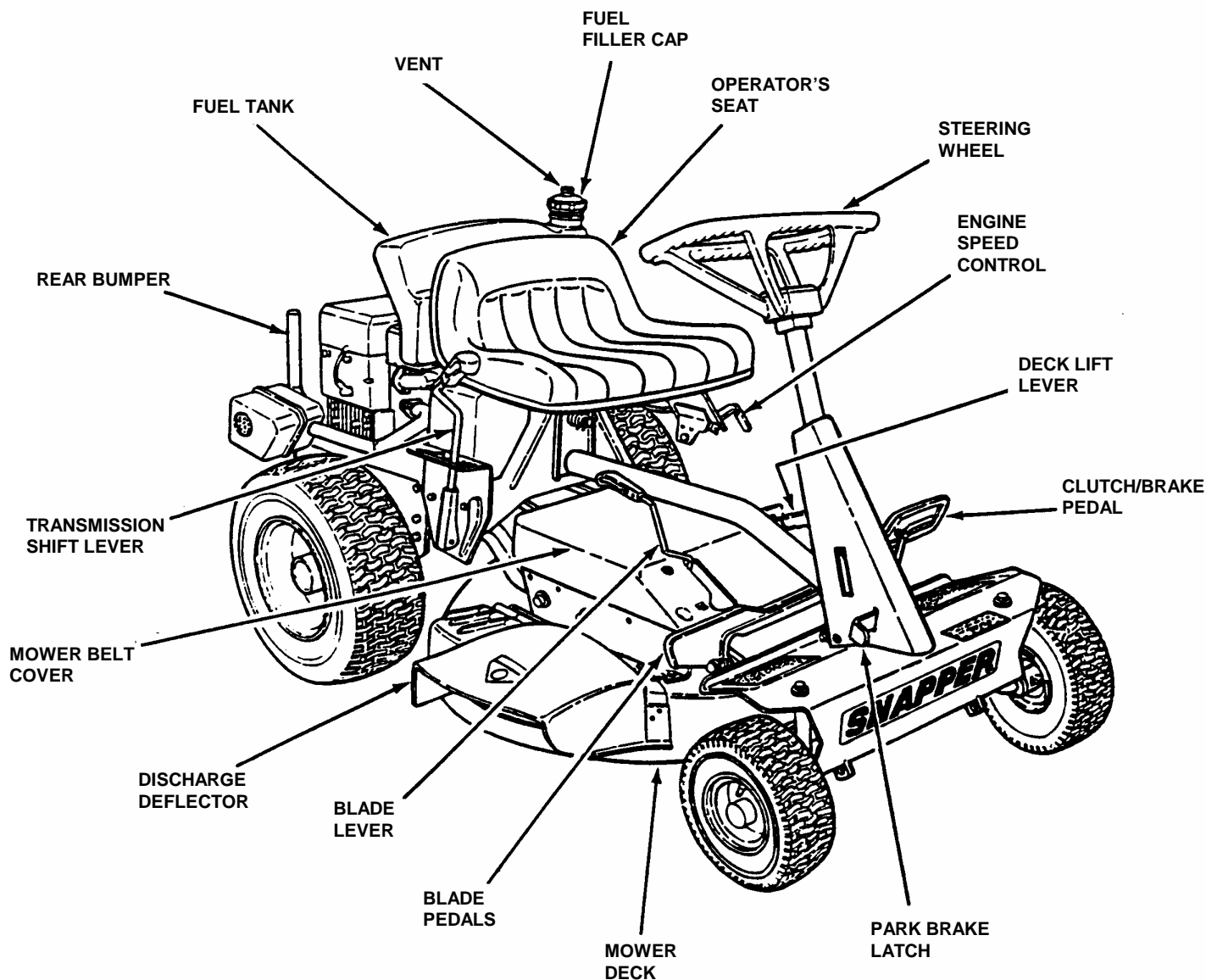

FIGURE 1.1

## 1.1 INTRODUCTION

This manual has been prepared for the operator's of the SNAPPER Rear Engine Rider. Its purpose, aside from recommending standard operating procedures and routine service requirements, is to promote SAFETY through the use of accepted operating practices. **Read, Understand and Follow** the IMPORTANT SAFETY INSTRUCTIONS on Pages 2 & 3 of this manual and **All SAFETY** messages on the Rear Engine Rider and its attachments before operating.

## 1.2 NOMENCLATURE

The nomenclature drawing above, Figure 1.1, shows the essential parts of the SNAPPER Rear Engine Rider. It is recommended that all operator's of this equipment become thoroughly familiar with the controls, components, and operation of this machine before operating. Specific details involving the engine are found in the separate engine owner's manual. Study these manuals before operating and keep both handy for future reference.

## Section 2 - OPERATING INSTRUCTIONS

### 2.1 PRE-START CHECK LIST

Make the following checks and perform the service required before each start-up.

**2.1.1.** Check tires and add or release air as needed to bring pressure to 12 psi in front and 12 psi in rear tires.

**2.1.2.** Check guards, deflectors and covers to make sure all are in place and securely tightened.

**2.1.3.** Check engine oil and add oil as needed to bring level up to the FULL mark. Refer to engine owner's manual for oil specifications. See Figure 2.1.

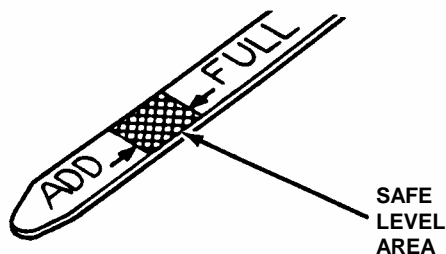

FIGURE 2.1

**2.1.4.** Adjust seat as needed to most comfortable position. Refer to Section "OPERATOR'S SEAT ADJUSTMENT".

**2.1.5.** Check blade control to insure it works freely. If blade pedals are depressed, blade lever can be moved manually from "ON" to "OFF" to stop blade.

**2.1.6.** Clean exterior surfaces of cutting deck and engine of any accumulation of dirt, grass, oil, etc. Keep engine air intake screen and cooling fins clear at all times.

**2.1.7.** Add fuel to tank after pushing the Rear Engine Rider outside where fumes can dissipate. Make sure fuel filler cap is tight and vent is open after refueling. Refer to engine owner's manual for fuel specifications. See Figure 2.2.

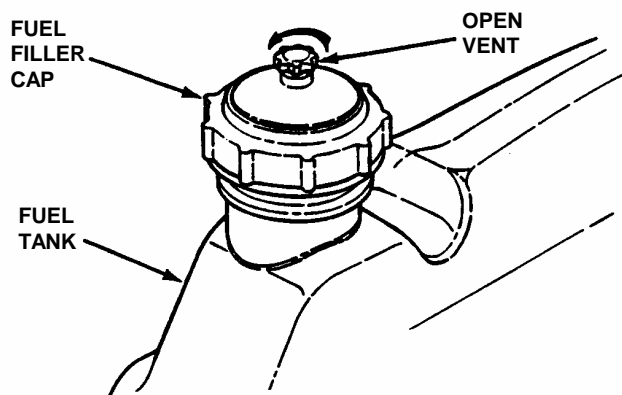

FIGURE 2.2

### 2.2 OPERATOR'S SEAT ADJUSTMENT

#### 2.2.1. FRONT TO REAR ADJUSTMENT

1. With the engine stopped, loosen the two adjusting knobs and move seat to desired position. After adjustment, tighten knobs securely. If seat does not move after loosening knobs, it may be necessary to loosen the 5/16" patch lock screws located at the rear of the seat using a 1/2 inch wrench. See Figure 2.3.

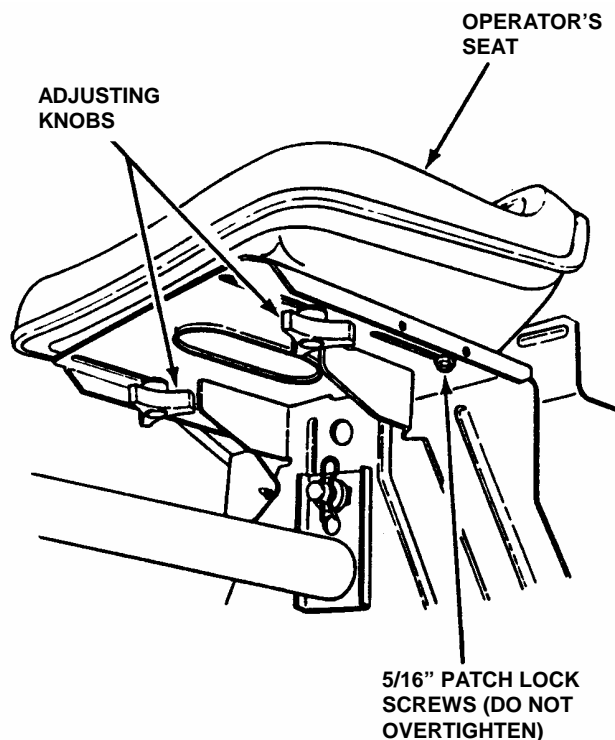

FIGURE 2.3

# Section 2 - OPERATING INSTRUCTIONS

## 2.3 STARTING & OPERATION

### 2.3.1. ENGINE (ELECTRIC START)

**IMPORTANT:** When the ignition key is turned to "START", the engine will turn over, but will not start unless the Clutch/Brake pedal is pressed all the way down, the Blade Lever is in the "Off" position (See Figure 2.5). The operator should be in the seat. Start engine as follows:

1. Move transmission shift lever to (N) Neutral position. **DO NOT** start engine with transmission shift lever in a drive position.



2. Make certain the Blade Lever is in the "Off" position. See Figure 2.4.

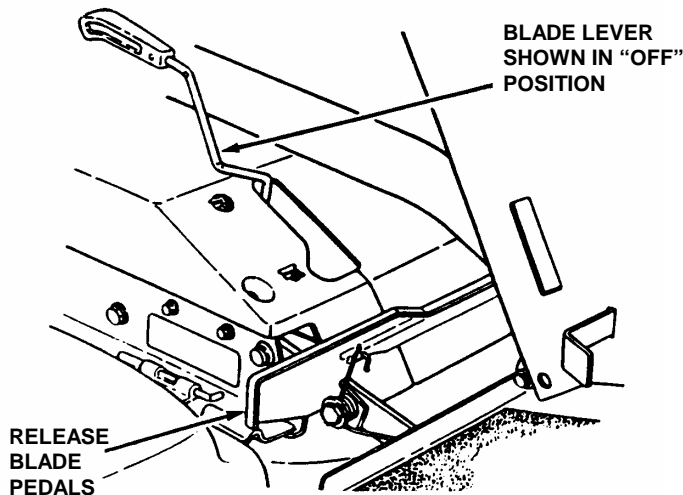

FIGURE 2.4

3. Press Clutch/Brake Pedal all the way down and hold while starting engine. See Figure 2.5.

4. Open vent on fuel filler cap by turning counterclockwise. **IMPORTANT:** Failure to open vent on the fuel filler cap can cause engine to stall. See Figure 2.2.

5. Move engine speed control to the choke position to start a cold engine. See Figure 2.6.

6. Turn key to the "START" position until engine starts. See Figure 2.7. **NOTE:** If after 5 seconds of cranking the engine and it does not start, release the key, make sure the Clutch/Brake Pedal is fully depressed and attempt starting again after waiting for approximately 20 seconds.

7. After engine starts, move engine speed control to the "FAST" position, allow a brief warm-up until engine runs smooth.

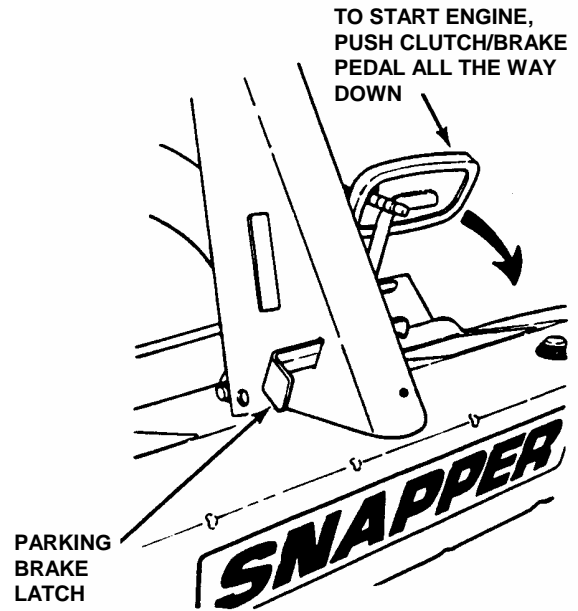

FIGURE 2.5

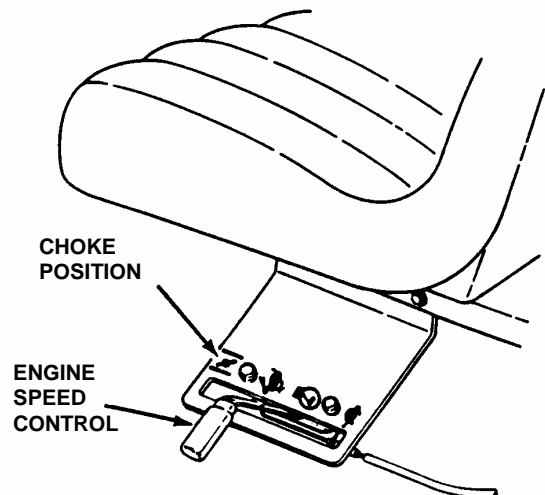

FIGURE 2.6

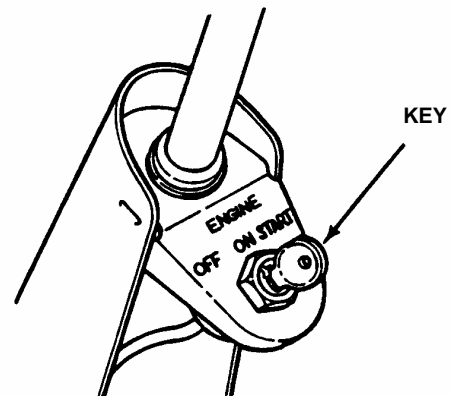

FIGURE 2.7  
(Continued on Next Page)

## Section 2 - OPERATING INSTRUCTIONS

### 2.3 STARTING & OPERATION

#### 2.3.1. ENGINE (ELECTRIC START) (Continued)

8. Should the battery be too weak to start the engine, Refer to Section "ENGINE (MANUAL START)" to manually start the electric start engines.

#### 2.3.2. ENGINE (MANUAL START)

**IMPORTANT:** When the ignition key is turned to "RUN", and the recoil handle is pulled, the engine will turn over, but will not start unless the Clutch/Brake Pedal is pressed all the way down with Parking Brake engaged (See Figure 2.8) and the Blade Lever is in the "Off" position (See Figure 2.4). Start engine as follows:

1. Move transmission shift lever to (N) Neutral position. DO NOT start engine with transmission shift lever in a drive position.

5. Move engine speed control to the choke position to start a cold engine. See Figure 2.6

6. Turn key to "RUN" position. See Figure 2.9.

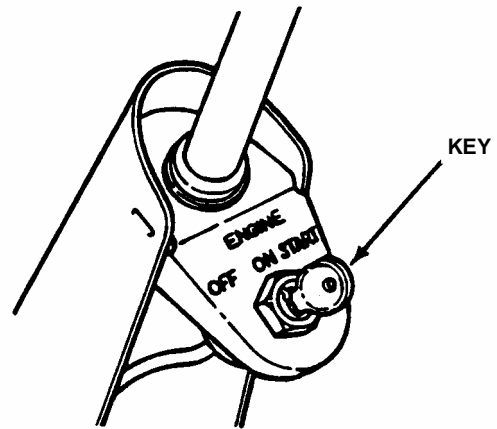

FIGURE 2.9

**WARNING**

It is possible to start engine with transmission shift lever in a drive position. Follow starting instructions carefully.

2. Make certain the Blade Lever is in the "Off" position. See Figure 2.4.

3. Press Clutch/Brake Pedal all the way down, move Parking Brake Latch over and release the Clutch/Brake Pedal to set Parking Brake. See Figure 2.8.

7. Pull starter rope with a smooth, even motion until engine starts. Always guide the starter rope back into the recoil housing. Never allow rope to snap back. After Engine starts, move engine speed control to the "FAST" position.

8. Allow a brief warm-up until engine runs smooth.

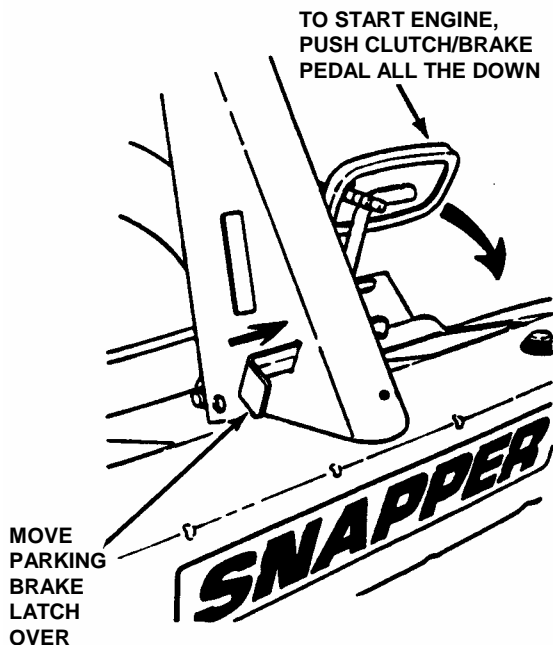

FIGURE 2.8

4. Open vent on fuel filler cap by turning counterclockwise. NOTE: Failure to open vent on the fuel filler cap can cause engine to stall. See Figure 2.2.



## Section 2 - OPERATING INSTRUCTIONS

**WARNING**

Once blade is disengaged, it should come to a complete stop in 3 seconds or less. If the blade continues to rotate after 3 seconds, the blade brake must be adjusted. Refer to Section "BLADE BRAKE ADJUSTMENT" for adjustment procedures or return machine to an authorized SNAPPER dealer for adjustment. DO NOT CONTINUE to operate machine until blade brake is adjusted and functioning properly.

### 2.3 STARTING & OPERATION

#### 2.3.3. MOWER BLADE

1. With engine running, move engine speed control to the "FAST" position.
2. Move blade lever forward to the "ON" position, then depress blade pedals to hold blade lever in the "ON" position. See Figure 2.10.

**IMPORTANT:** You cannot engage the blade lever if the blade pedal is depressed first.

BLADE LEVER  
SHOWN IN "ON"  
POSITION

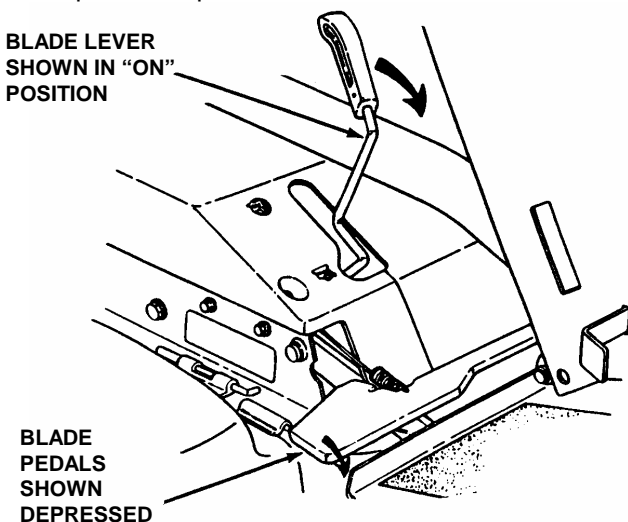

FIGURE 2.10

#### 2.3.4. WHEEL DRIVE

1. With engine running, adjust engine speed control to "FAST" position.
2. Depress clutch/brake pedal. See Figure 2.11.
3. Place transmission shift lever in the notch for 1<sup>st</sup> speed. See Figure 2.12.
4. Release clutch/brake pedal to begin desired ground speed.
5. During forward motion, the transmission shift lever may be placed in any desired forward speed without depressing the clutch/brake pedal.

**NOTE:** For best cutting results, move the transmission shift lever into a slow forward speed and the engine speed control to a fast position. This combination will allow the mower blades to lift the grass while cutting smoothly and evenly.

**WARNING**

DO NOT operate blades in reverse. STOP BLADES. LOOK and SEE behind and down for children, pets and hazards before and while backing.

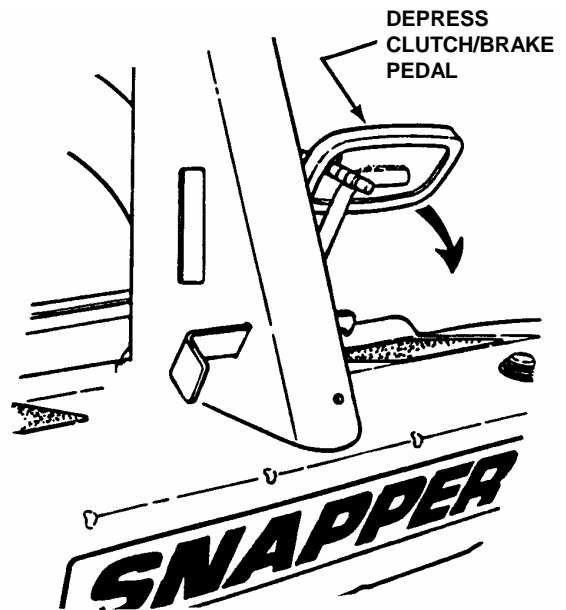

FIGURE 2.11

TRANSMISSION  
SHIFT LEVER (MOVE  
TO DESIRED SPEED)

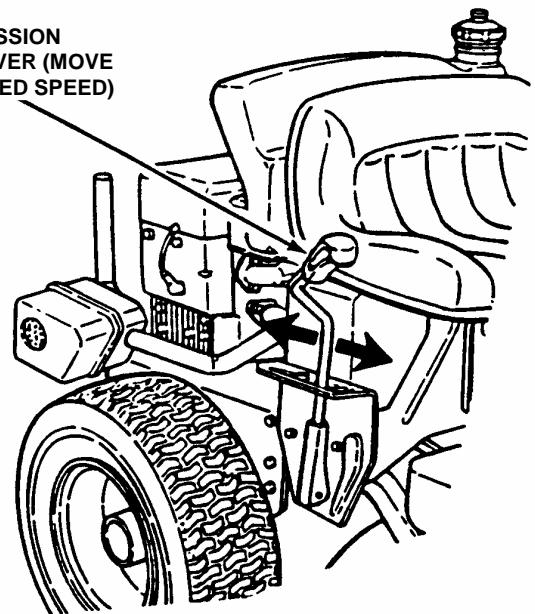

FIGURE 2.12

## Section 2 - OPERATING INSTRUCTIONS

**WARNING**  
DO NOT leave machine with the engine running. Stop engine. Stop blade. Shift to neutral. Engage parking brake. Remove key.

### 2.4 STOPPING - ENGINE, WHEEL DRIVE, BLADE

#### 2.4.1. ENGINE

1. Stop engine by turning key to the "OFF" position. See Figure 2.13.

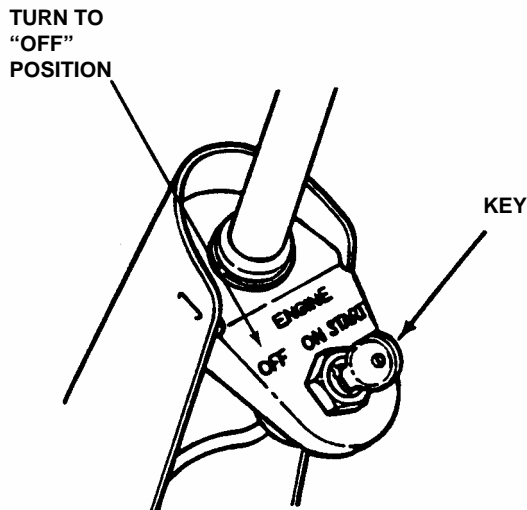

FIGURE 2.13

#### 2.4.2. WHEEL DRIVE

1. Stop motion of Rear Engine Rider by pushing clutch/brake pedal all the way "DOWN" to apply brake. See Figure 2.14.

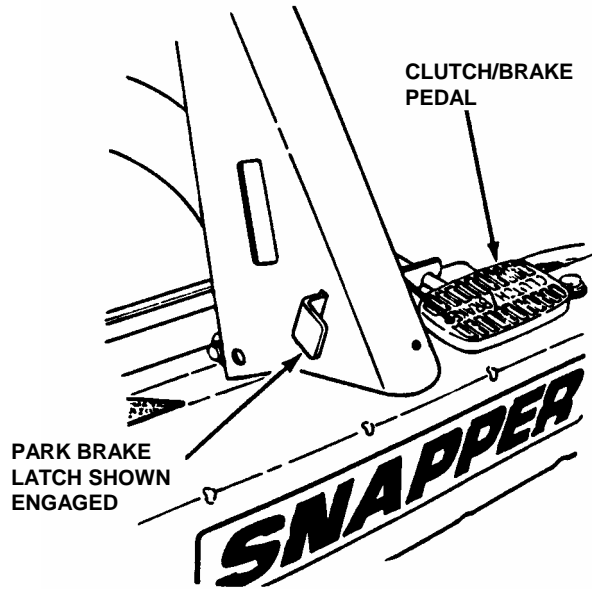

FIGURE 2.14

**WARNING**  
Once blade is disengaged, it should come to a complete stop in 3 seconds or less. If the blade continues to rotate after 3 seconds, the blade brake must be adjusted. Refer to Section "BLADE BRAKE ADJUSTMENT" for adjustment procedures or return machine to an authorized SNAPPER dealer for adjustment. DO NOT CONTINUE to operate machine until blade brake is adjusted and functioning properly.

#### 2.4.3. MOWER BLADE

1. Stop mower blade by releasing blade pedals or moving blade lever rearward to the "OFF" position. See Figure 2.15.

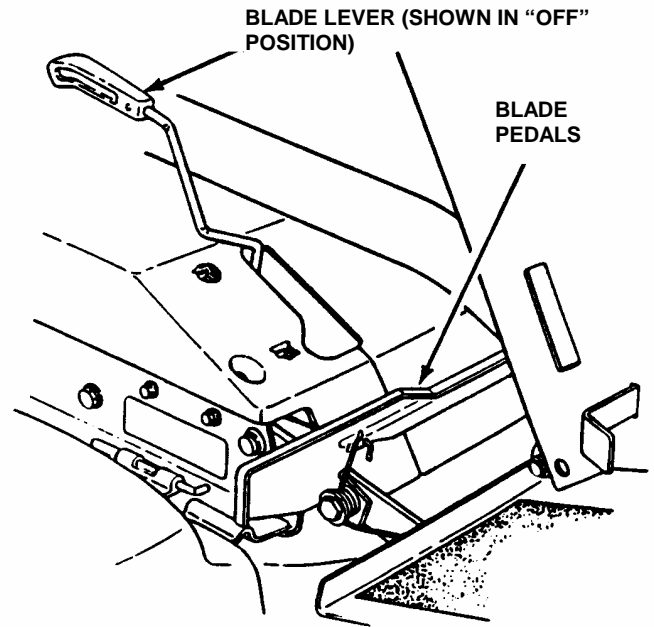

FIGURE 2.15

(Continued on Next Page)

## Section 2 - OPERATING INSTRUCTIONS

### 2.4 STOPPING - ENGINE, WHEEL DRIVE, BLADE

#### 2.4.4. PARK BRAKE

1. Engage park brake by pushing clutch/brake pedal "DOWN" and moving the park brake latch to the "ENGAGED" position. While holding the park brake latch "ENGAGED", release clutch/brake pedal to set park brake. See Figure 2.16.

### 2.5. CUTTING HEIGHT ADJUSTMENT

1. Adjust cutting height as desired to any one of five positions using deck lift lever. Move deck lift lever up or down to desired cutting height and then move over to secure in the height of cut notch. See Figure 2.18.

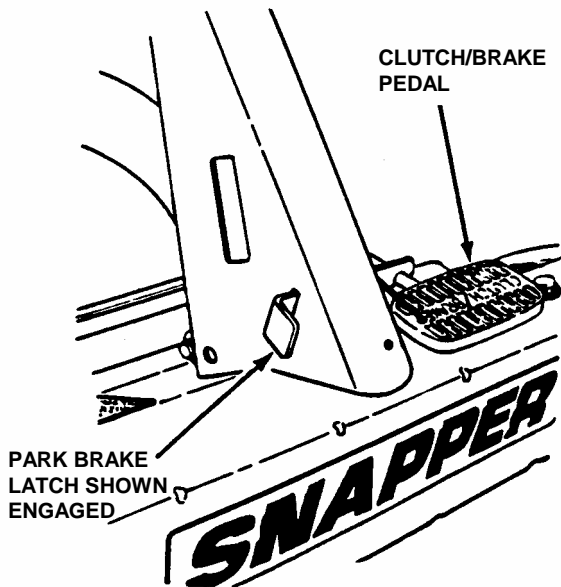

FIGURE 2.16

2. Release park brake by pushing down on the clutch/brake pedal, parking brake latch will move to the "OFF" position unassisted. See Figure 2.17.

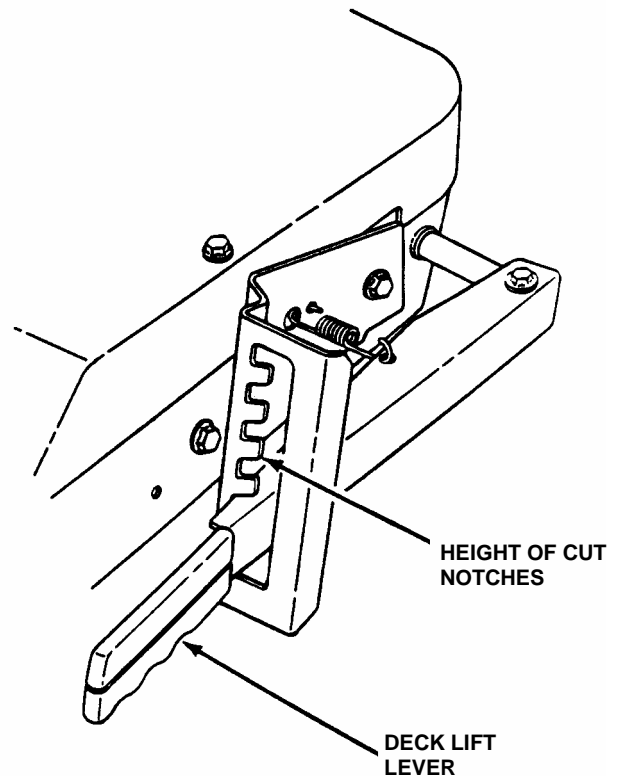

FIGURE 2.18

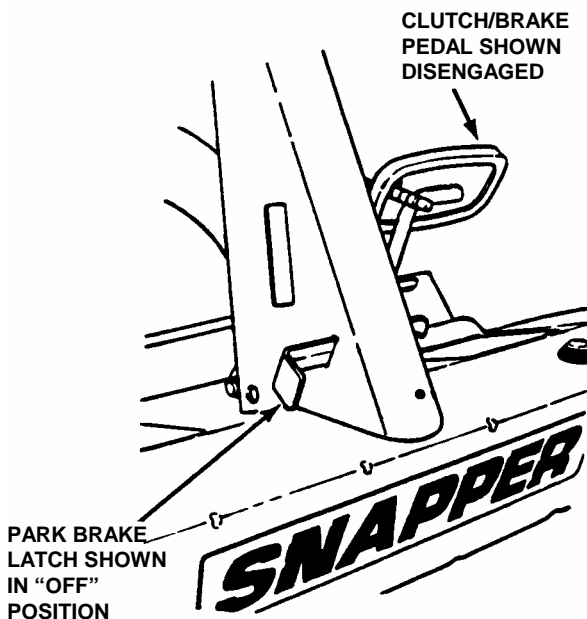

FIGURE 2.17

## Section 3 - MAINTENANCE

**WARNING**  
DO NOT attempt any adjustments, maintenance, service or repairs with the engine running. STOP engine. STOP blade. Engage parking brake. Remove key. Remove spark plug wire from spark plug and secure away from plug. Engine and components are HOT. Avoid serious burns, allow all parts to cool before working on machine. Fuel Filler Cap and vent must be closed securely to prevent fuel spillage.

### 3.1 INTRODUCTION

To retain the quality of the Rear Engine Rider, use genuine SNAPPER replacement parts only. Contact a local SNAPPER dealer for parts and service assistance. For the correct part or information for a particular Rear Engine Riding Mower, always mention the model and serial number. SNAPPER recommends returning the Rear Engine Rider to an authorized SNAPPER dealer annually for inspection and addition of any new devices which might upgrade the safety of the Rear Engine Rider. For the nearest SNAPPER dealer in your area, check the yellow pages under the heading LAWN MOWERS. For engine parts and service, look for the engine manufacturer's dealers under the heading, ENGINES - gasoline.

### 3.2 SERVICE - AFTER FIRST 5 HOURS

Routine maintenance is important to the performance and life of your Rear Engine Rider. Service performed properly and at the recommended interval is essential. Refer to Section "MAINTENANCE SCHEDULE" in this manual and in the Engine Owner's Manual. Carefully complete all of the recommended service procedures.

#### 3.2.1. CHANGE ENGINE OIL

1. Place bricks or wooden blocks under the front wheels to lower rear of engine.
2. Loosen or remove oil fill cap on engine.
3. Loosen oil drain plug.
4. Place a 2 quart minimum capacity container under the end of the oil drain. Open oil drain. See Figure 3.1 for oil drains used on the Rear Engine Riders.

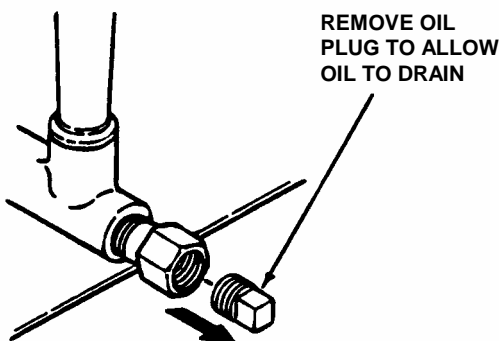

FIGURE 3.1

5. After all the oil has drained, close the drain and wipe up any oil that may have spilled. See Figure 3.1. Dispose of used oil properly.
6. Fill engine crankcase with new oil. Refer to your engine owner's manual for oil specifications.

#### 3.2.2. SERVICE ENGINE AIR CLEANER

The engine is equipped with a dual element air cleaner. Both the foam pre-cleaner and cartridge require service. Refer to Engine Owner's Manual for recommended service procedures.

#### 3.2.3. CHECK MOWER BLADE

1. Follow **WARNING** statement found on this page.
2. Check fuel level in tank. If over 3/4 full, remove tank. Refer to Section "REMOVING FUEL TANK". If 3/4 or less, proceed to next step.
3. Carefully stand Rear Engine Rider on rear bumper.

**WARNING**  
Remove the battery if the Rear Engine Rider will be left standing on the rear bumper for longer than 2 hours. See Section on BATTERY REMOVAL. DO NOT use a cutting blade that shows signs of excessive wear or damage on the Rear Engine Rider. Refer to Section on MOWER BLADE REPLACEMENT for proper blade inspection and service procedures.

4. Check torque of blade mounting bolts. As necessary, torque to 30 to 40 ft. lbs. See Figure 3.2.
5. Check blade for sharpness, wear and damage. See Section on BLADE WEAR LIMITS.

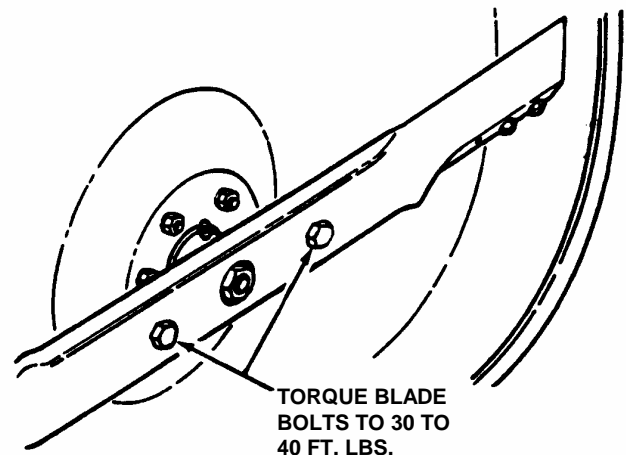

FIGURE 3.2

6. Check blade for straightness. Refer to Section on ADJUSTING MOWER BLADE.

## Section 3 - MAINTENANCE

**WARNING**  
DO NOT attempt any adjustments, maintenance, service or repairs with the engine running. STOP engine. STOP blade. Engage parking brake. Remove key. Remove spark plug wire from spark plug and secure away from plug. Engine and components are HOT. Avoid serious burns, allow all parts to cool before working on machine. Fuel Filler Cap and vent must be closed securely to prevent fuel spillage.

### 3.2 SERVICE - AFTER FIRST 5 HOURS

#### 3.2.4. CHECK BLADE DRIVE BELT

The blade drive consists of a single belt from the engine to the deck. Inspect for signs of deterioration and proper tension.

1. Lower deck to lowest setting.
2. Remove four self-tapping screws, two on each side of mower drive belt cover. See Figure 3.3.
3. Slide cover back and rotate out.

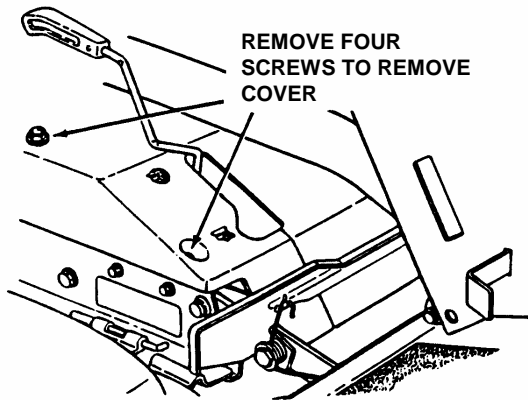

FIGURE 3.3

4. With engine "OFF" and deck in 3rd height of cut position, move blade lever back to the "ON" position and depress blade pedals.

5. Measure the belt spacing at idler pulley. See Figure 3.4. The belt spacing should be 1 1/4" but no less 1". If the measurement is less than 1", the belt tension should be adjusted. Refer to Section "MOWER DRIVE BELT ADJUSTMENT".

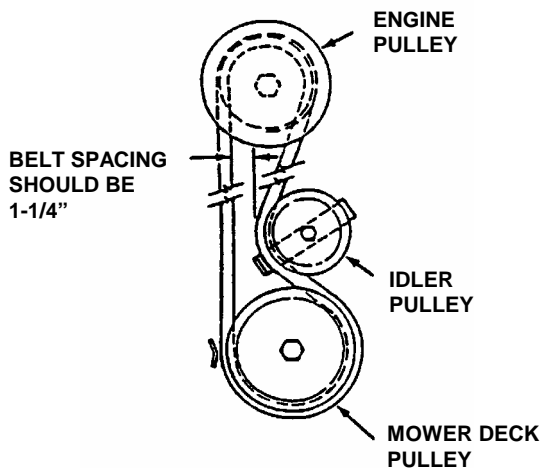

FIGURE 3.4

#### 3.2.5. BLADE BRAKE

1. Check blade brake for proper function. Blade should stop rotating in 3 seconds or less after moving the blade control lever to the "OFF" position or after releasing the blade pedals.

**WARNING**  
Blades must stop rotating in 3 seconds or less after the blade has been turned off. DO NOT operate machine until blade brake has been adjusted and functioning properly.

2. If the blade continues to rotate longer than 3 seconds do not operate machine. Refer to Section "BLADE BRAKE ADJUSTMENT" or contact your SNAPPER dealer for assistance.

#### 3.2.6. SERVICE BRAKE / PARK BRAKE

1. Check machine brake for proper function. Engage park brake. Push machine. Rear tires should skid. Drive machine forward and apply brake. Machine should come to a complete stop in less than 5 ft.

2. If brakes are not functioning properly brake adjustment must be completed before operating machine. Refer to Section "SERVICE BRAKE - PARK BRAKE ADJUSTMENT".

#### 3.2.7. INTERLOCK SYSTEM

Check interlock controls for proper function:

**The engine MUST NOT start if:**

1. Blade Control is "ON" and/or clutch/brake pedal is released.

**The engine and blades MUST STOP if:**

2. The operator leaves the operator position with Blade Control "ON" and/or clutch/brake pedal is released.

**WARNING**  
DO NOT operate machine if interlock system is not functioning properly. Contact your SNAPPER dealer immediately for assistance.

## Section 3 - MAINTENANCE



### 3.2.8. LUBRICATION – GREASE FITTINGS

The following components on the Rear Engine Rider are equipped with grease fittings and require periodic lubrication. Apply General Purpose grease (NLGI No.2) with a grease gun.

1. Front Wheel Bearings. Refer to Section “FRONT WHEEL BEARINGS – LUBRICATION”.
2. Rear Axle Bearing. Refer to Section “REAR AXLE BEARING – LUBRICATION”.
3. Mower Blade Spindle. Refer to Section “MOWER BLADE SPINDLE – LUBRICATION”.

### 3.3 SERVICE - EVERY 25 OPERATING HOURS

3.3.1. Perform all service required after the first 5 hours of operation. Refer to Section “SERVICE – AFTER 5 HOURS”.

	<b>WARNING</b>	
<p>DO NOT attempt any adjustments, maintenance, service or repairs with the engine running. Stop engine. Stop blade. Engage parking brake. Remove key. Remove spark plug wire from spark plug and secure away from plug. Engine and components are HOT. Avoid serious burns, allow all parts to cool before working on machine. Fuel Filler Cap and Vent must be closed securely to prevent fuel spillage.</p>		

### 3.3.2. BATTERY FLUID LEVEL

1. Remove battery. Refer to Section “BATTERY REMOVAL”.
2. Remove battery caps. Check fluid level.
3. Add water only to bring fluid to proper level – approximately 3/16” above plates.

**DO NOT OVERFILL.**

4. Reinstall battery. Refer to Section “BATTERY INSTALLATION”.

### 3.3.3. MOWER DECK LEVELNESS

Check mower deck for proper level. Adjust as required. Refer to Section “MOWER DECK ADJUSTMENT – LEVELNESS”.

### 3.3.4. CLEAN MOWER DECK

1. Follow **WARNING** statement found on this page.
2. Check fuel level in tank. If over 3/4 full, remove tank. Refer to Section “REMOVING FUEL TANK”. If 3/4 or less, proceed to next step.
3. Carefully stand Rear Engine Rider on rear bumper.
4. Clean underside of mower deck, removing all accumulation of grass clippings and debris.
5. Clean top of deck, removing all grass clippings and debris.

### 3.3.5 MOWER BLADE SPINDLE - LUBRICATION

1. Follow **WARNING** statement found on this page.
2. Check fuel level in tank. If over 3/4 full, remove tank. Refer to Section “FUEK TANK REMOVAL”. If 3/4 or less, proceed to next step.
3. Carefully stand Rear Engine Rider on rear bumper.
4. Lubricate spindle with three shots of general purpose grease from grease gun. See Figure 3.5.

**IMPORTANT:** If the Rear Engine Rider will be on its rear bumper for longer than two hours, remove the battery. Refer to Section “BATTERY REMOVAL”.

**3.3.6. MOWER DECK LINKAGE - LUBRICATION**  
Lubricate all mower deck linkage pivot points with a light coat of motor oil.

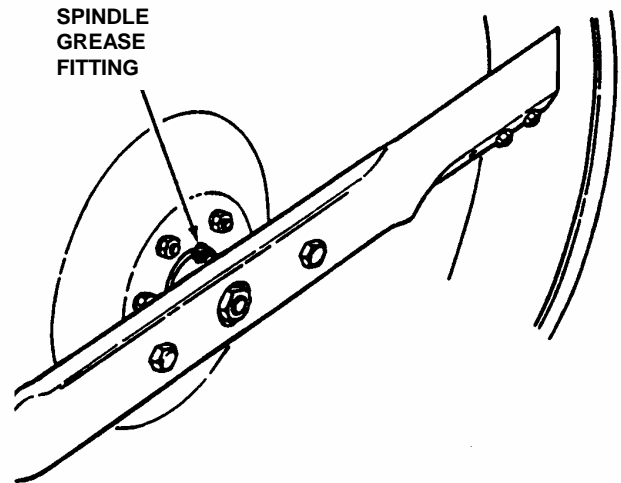

FIGURE 3.5

### 3.3.7. FRONT WHEEL BEARING - LUBRICATION

1. Lubricate front wheel bearings with five shots of general purpose grease, from grease gun. See Figure 3.6.

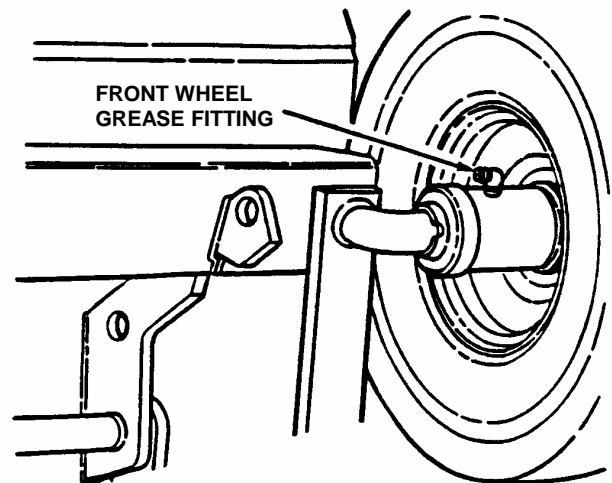

FIGURE 3.6

(Continued on Next Page)

## Section 3 - MAINTENANCE

### 3.3 SERVICE - EVERY 25 OPERATING HOURS

#### 3.3.8. REAR AXLE BEARING

1. The left rear axle bearing requires three shots of general purpose grease from grease gun. See Figure 3.7.

**NOTE:** Some models are equipped with a pre-lubricated sealed bearing and require no additional lubrication.

2. The right rear axle bearing is lubricated by the differential lubricant and requires no grease.

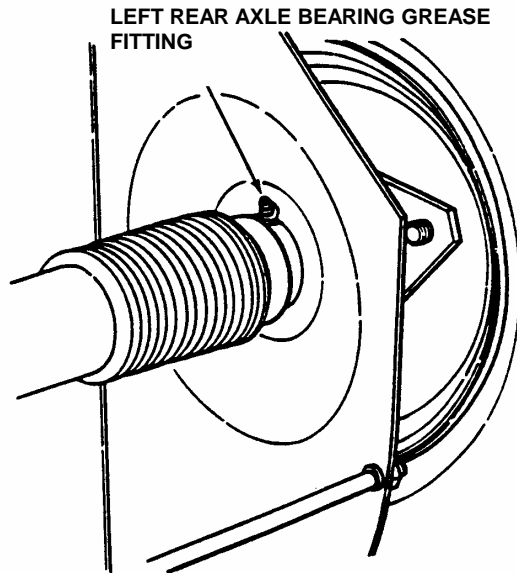

FIGURE 3.7

#### 3.3.9. DIFFERENTIAL/CHAIN CASE - LUBRICATION

1. Stand rear engine rider on its rear bumper and check the fill/level plug, for cracks and wear. Replace fill/level plug if signs of wear are visible.

**IMPORTANT:** If the Rear Engine Rider will be on its rear bumper for longer than two hours, remove the battery. See Section on BATTERY REMOVAL.

2. To check lubricant, remove fill/level plug and visually inspect for lubricant on the internal parts of the differential. If no lubricant is visible on the internal parts of the differential, add "SNAPPER Transmission" grease as needed. See Figure 3.8.

**IMPORTANT:** Overfilling of the differential with lubricant will cause lubricant to leak onto drive components of the Rear Engine Rider.

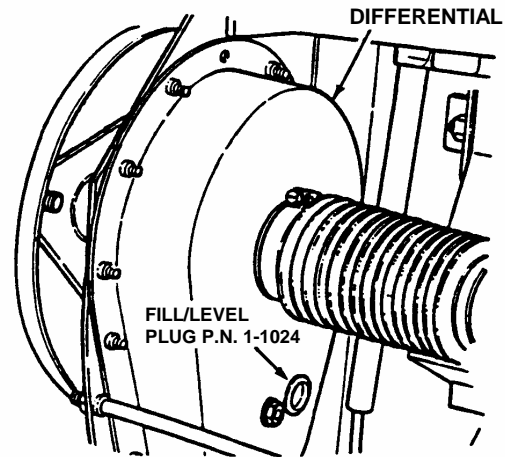

FIGURE 3.8

**WARNING**

DO NOT attempt any adjustments, maintenance, service or repairs with the engine running. STOP engine. STOP blade. Engage parking brake. Remove key. Remove spark plug wire from spark plug and secure away from plug. Engine and components are HOT. Avoid serious burns, allow all parts to cool before working on machine. Fuel Filler Cap and vent must be closed securely to prevent fuel spillage.

3. Check fill/level plug for damage. If signs of wear or cracks are visible, replace plug with new plug. See Figure 3.9.

4. To check lubricant in chain case, remove fill/level plug and look for lubricant on the internal components of the chain case. If no lubricant is visible, add "SNAPPER Transmission" grease as needed. See Figure 3.9.

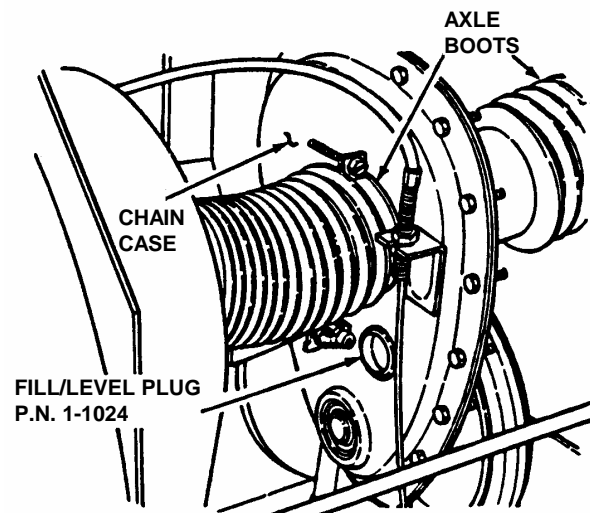

FIGURE 3.9

3.3.10. Check "MAINTENANCE SCHEDULE" Section of Engine Owner's Manual for additional engine service.

## Section 3 - MAINTENANCE

### 3.4 SERVICE - ANNUALLY

3.4.1. Perform all maintenance as specified in "MAINTENANCE SCHEDULE" Section of this manual.

#### 3.4.2. FUEL FILTER

Service fuel filter as instructed below, on COLD ENGINE ONLY!

**IMPORTANT:** To stop flow of fuel, tank may be removed from bracket and set on the floor so the fuel level will be below the filter. Refer to Section "REMOVING FUEL TANK".

1. Remove hose clamps from fuel filter.
2. Remove fuel lines from filter. Discard filter.
3. Install new fuel filter. See Figure 3.10.
4. Reinstall fuel tank into bracket.

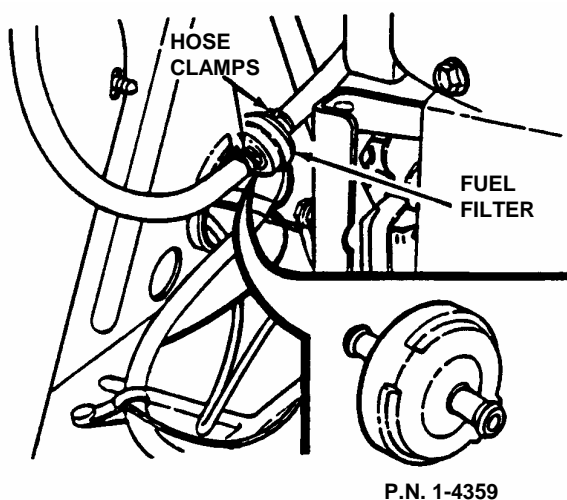

FIGURE 3.10

### 3.5 EVERY TWO YEARS

In addition to regular maintenance, the following components of the Rear Engine Rider should be carefully inspected every two years for wear or damage. Replace worn or damaged parts with genuine SNAPPER replacement parts available from an authorized SNAPPER dealer.

- 3.5.1. All bushings and pivot areas.
- 3.5.2. Check both front wheel king pins.
- 3.5.3. Transmission shift lever and detent.
- 3.5.4. Clutch disc.
- 3.5.5. Clutch Yoke (See Figure 4.9).
- 3.5.6. Mower deck linkage and pivot areas.

**WARNING**

**DO NOT attempt any adjustments, maintenance, service or repairs with the engine running. Stop engine. Stop blade. Engage parking brake. Remove key. Remove spark plug wire from spark plug and secure away from plug. Engine and components are HOT. Avoid serious burns, allow all parts to cool before working on machine. Fuel Filler Cap and Vent must be closed securely to prevent fuel spillage.**

### 3.6 STORAGE (OUT OF SEASON)

If desired, the Rear Engine Rider can be stored on the rear bumper. Perform the following procedures to insure the Rear Engine Rider will operate properly when taken out of storage.

- 3.6.1. Thoroughly clean the Rear Engine Rider by removing all grass clippings and debris.
- 3.6.2. Perform maintenance and lubrication as required.
- 3.6.3. Drain fuel from fuel tank.
- 3.6.4. Start engine and allow it to run until engine runs out of fuel. This allows the carburetor and fuel system to remain clean during storage.
- 3.6.5. Remove battery. Refer to Section "BATTERY STORAGE".
- 3.6.6. Close vent on fuel filler cap.
- 3.6.7. Carefully stand Rear Engine Rider on rear bumper in desired location for storage.

### 3.7 REMOVING FUEL TANK

Before removing fuel tank from rear engine rider, move rider outdoors where fumes can be easily dissipated. Removal of the tank is accomplished from the left side of the machine by pulling the tank straight up and away from the fuel tank bracket. See Figure 3.11. Holding the fuel tank, remove the fuel filler cap and pour remaining fuel in an approved container.

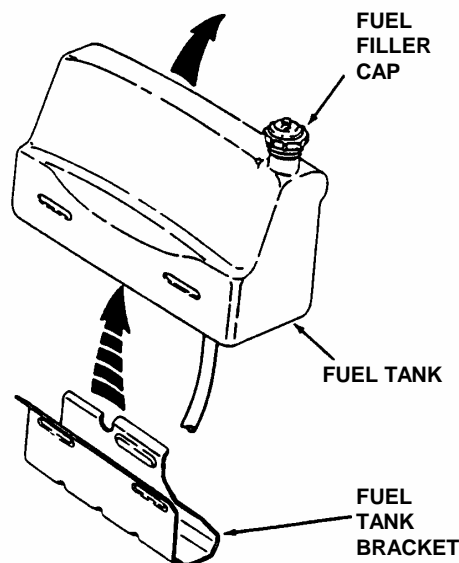

FIGURE 3.11



## Section 4 - ADJUSTMENTS & REPAIR

**WARNING**  
DO NOT attempt any adjustments, maintenance, service or repairs with the engine running. Stop engine. Stop blade. Engage parking brake. Remove key. Remove spark plug wire from spark plug and secure away from plug. Engine and components are HOT. Avoid serious burns, allow all parts to cool before working on machine. Fuel Filler Cap and Vent must be closed securely to prevent fuel spillage.

### 4.1 ENGINE ADJUSTMENTS & REPAIR

Refer to the engine owner's manual for those adjustments and/or repairs that can be made by the owner.

### 4.2 MOWER DECK & COMPONENT ADJUSTMENTS

The following mower deck and component adjustments and repairs can be made by the owner. However, if there is difficulty in achieving these adjustments and repairs, it is recommended that these repairs be made by an authorized SNAPPER dealer.

**WARNING**  
Once blade is disengaged it should come to a stop in 3 seconds or less. If the blade continues to rotate after 3 seconds the blade brake must be adjusted. DO NOT continue to operate the machine if the blade brake is not operating properly.

#### 4.2.1. MOWER DRIVE BELT ADJUSTMENT (FOR 25", 28" & 30" "M" MODELS)

1. Remove mower drive belt cover. Refer to Section "CHECK BLADE DRIVE BELT".
2. Move blade lever up and over to the "ON" position.
3. Place deck cutting height in the 3rd position. Measure the belt spacing at idler pulley. The distance should measure 1-1/4" but no less than 1". See Figure 4.1.

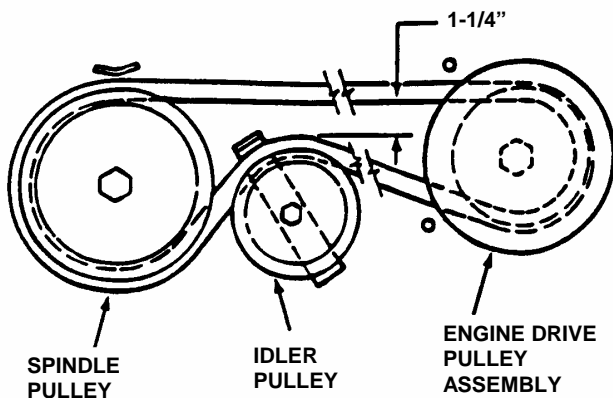

FIGURE 4.1

4. If the distance is less than 1", adjust belt tension.
5. Remove hairpin and flat washers from pivot stud. See Figure 4.2.
6. Pull front frame forward until distance between belt, with blade lever "ON", measures 1-1/4".

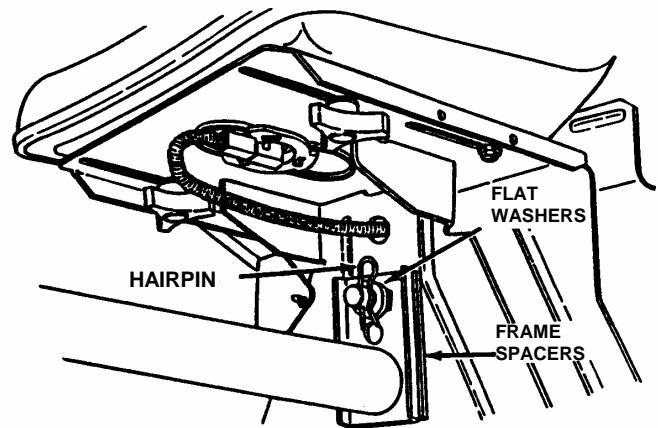

FIGURE 4.2

7. Install required number of snap-in frame spacers behind channel pivot until the 1-1/4" distance between belt is maintained. See Figure 4.3.

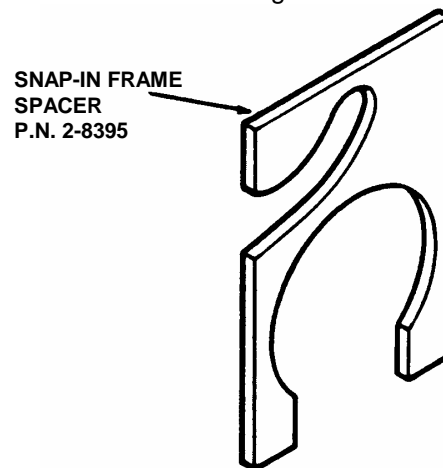

FIGURE 4.3

8. Reinstall the required amount of flat washers removed in step "5." and install hairpin. See Figure 4.2. Retain any remaining spacers for readjustment when a new belt is installed.

**IMPORTANT:** The SNAPPER "M" Series Rear Engine Rider Models are shipped with additional spacers specifically designed for the Rear Engine Rider. Should additional spacers be required, contact an authorized SNAPPER dealer.

## Section 4 - ADJUSTMENTS & REPAIR

**WARNING**

Once blade is disengaged it should come to a stop in 3 seconds or less. If the blade continues to rotate after 3 seconds the blade brake must be adjusted. **DO NOT** continue to operate the machine if the blade brake is not operating properly.

### 4.2.2. BLADE BRAKE ADJUSTMENT

The automatic Blade Brake should stop the blades within 3 seconds anytime the blades are disengaged by moving blade lever to the "OFF" position or by releasing the Blade Pedals. When the Blade Brake is properly adjusted there should be 1/8" to 1/4" clearance between the Blade Engagement Lever and the back of the Latch Plate. Check this by disengaging the Blade Lever and depressing the Blade Pedals as shown in Figure 4.2. If clearance is greater than 1/4" perform the following adjustment.

1. Remove Belt Cover. Refer to Section "BLADE BELT COVER REMOVAL".
2. With the blade engagement lever disengaged, hold the blade pedals down and measure the distance between the front of the blade lever and the rear of the latch plate. The dimension should be 1/8" to 1/4" clearance between lever and plate. See Figure 4.5. If the dimension is incorrect go to step 3.
3. If dimension is greater than 1/4", rotate nut clockwise to increase brake tension. If dimension is less than 1/8", rotate nut counter-clockwise to decrease brake tension. See Figure 4.4.
4. Reinstall spindle cover.

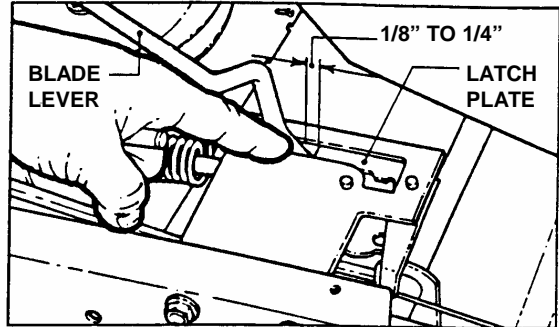

FIGURE 4.5

**WARNING**

**DO NOT** attempt any adjustments, maintenance, service or repairs with the engine running. Stop engine. Stop blade. Engage parking brake. Remove key. Remove spark plug wire from spark plug and secure away from plug. Engine and components are HOT. Avoid serious burns, allow all parts to cool before working on machine. Fuel Filler Cap and Vent must be closed securely to prevent fuel spillage.

### 4.2.3. MOWER DECK ADJUSTMENT (Side-To-Side Levelness)

Before making deck leveling adjustments, check the tire pressure. Front tires 12 psi, rear tires 12 psi. If tires are properly inflated and mowing is still uneven, adjust side-to-side deck levelness.

1. Place Rider on a smooth level surface.
2. Follow **WARNING** statement found on this page.
3. Place a piece of angle iron, pipe, or similar object under center of deck at the rear.
4. Remove rear hanger chains and allow center, rear of deck to rest on angle iron.
5. Measure the distance from blade tips to floor. If the measurement is within 1/8" from side-to-side, the deck attitude is satisfactory. If difference from side-to-side is greater than 1/8", continue with adjustment.
6. Loosen the carriage bolt and nut retaining the left side of the front lift arm and adjuster. Only loosen the bolt and nut to the point where some tension remains but lift arm can be moved.

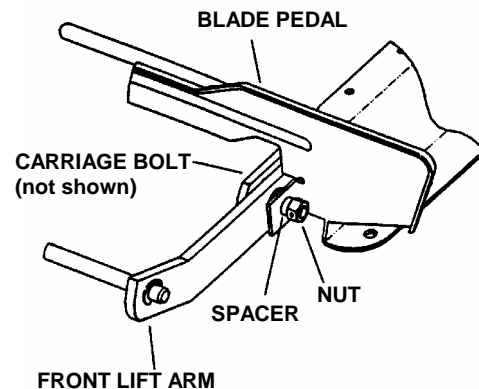

FIGURE 4.6

**WARNING**

**DO NOT** operate machine until blade brake is adjusted and functioning properly. If blade stop time can not be achieved with the adjustment procedure described above, take machine immediately to an authorized Snapper dealer.

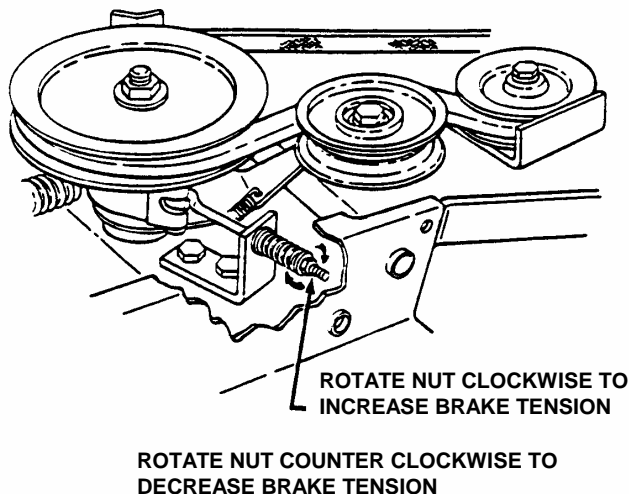

FIGURE 4.4

## Section 4 - ADJUSTMENTS & REPAIR

**WARNING**

DO NOT attempt any adjustments, maintenance, service or repairs with the engine running. Stop engine. Stop blade. Engage parking brake. Remove key. Remove spark plug wire from spark plug and secure away from plug. Engine and components are HOT. Avoid serious burns, allow all parts to cool before working on machine. Fuel Filler Cap and Vent must be closed securely to prevent fuel spillage.

### 4.2.3. MOWER DECK ADJUSTMENT (Side-To-Side Levelness) (Continued from previous page)

7. Move one side of the deck up or down to achieve levelness between both sides of deck. See Figure 4.6.
8. Tighten carriage bolt and nut securely. Recheck both sides of deck for correct levelness.
9. Readjust rear hanger chain pivots to align with holes in support brackets. See Figure 4.7.
10. Remove angle iron, pipe, or similar object and proceed to check front to rear levelness.

### 4.2.3. MOWER DECK ADJUSTMENT (Front to Rear Levelness - 25" & 28" Decks)

With the Rear Engine Rider on a smooth, level surface, rotate blade until blade tips are at front and rear of deck. Measure the distance from blade tips to floor. The distance should be the same, or the rear 1/8" lower than the front. If the rear blade tip is higher or is more than 1/8" lower than the front, proceed with adjustment.

### (Front to Rear Levelness - 30" Decks)

With the Rear Engine Rider on a smooth, level surface, rotate blade until blade tips are at front and rear of deck. Measure the distance from blade tips to floor. The distance should be the same, or the rear 1/8" to 1/4" higher than the front. If the rear blade tip is higher or is more than 1/4" higher than the front, proceed with adjustment.

1. Remove rear hanger chains.
2. Turn each hanger pivot the same number of rotations on the eye-bolt to raise or lower the rear of the deck. See Figure 4.7.
3. Reinstall rear hanger chains and measure blade tips again.
4. Repeat steps "1" through "3" until proper levelness is obtained.

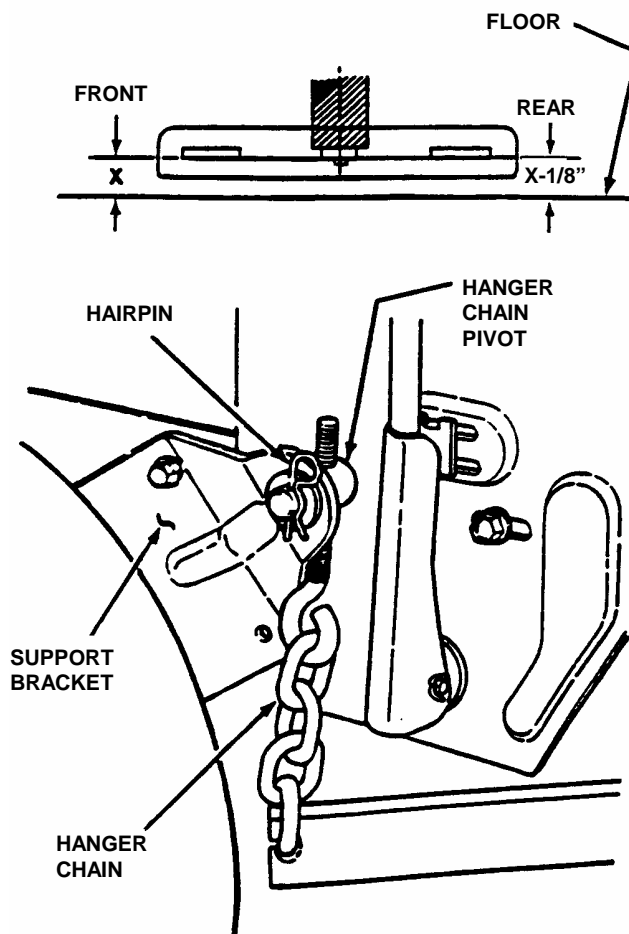

FIGURE 4.7

## Section 4 - ADJUSTMENTS & REPAIR

**WARNING**  
DO NOT attempt any adjustments, maintenance, service or repairs with the engine running. Stop engine. Stop blade. Engage parking brake. Remove key. Remove spark plug wire from spark plug and secure away from plug. Engine and components are HOT. Avoid serious burns, allow all parts to cool before working on machine. Fuel Filler Cap and Vent must be closed securely to prevent fuel spillage.

### 4.3 REAR ENGINE RIDER DRIVE COMPONENTS

Your Snapper rider is equipped with a patented smooth start clutch. The clutch should operate smoothly and provide ample traction. If problems are experienced, contact your Snapper dealer for repair.

#### 4.3.1. WHEEL BRAKE ADJUSTMENT

Test the wheel brake on a dry concrete surface. When properly adjusted, the Rear Engine Rider will stop within 5 feet from fastest speed. If stopping distance is more than 5 feet, the wheel brake should be adjusted as follows:

1. Follow **WARNING** statement found on this page.
2. Check fuel level in tank. If over 3/4 full, remove tank. Refer to Section "REMOVING FUEL TANK". If 3/4 or less, proceed to next step.
3. Carefully stand Rear Engine Rider on rear bumper.
4. Depress clutch/brake pedal all the way down. Move and hold the park brake lever in the "ON" position and release the clutch/brake pedal to lock the park brake. See Figure 4.8.

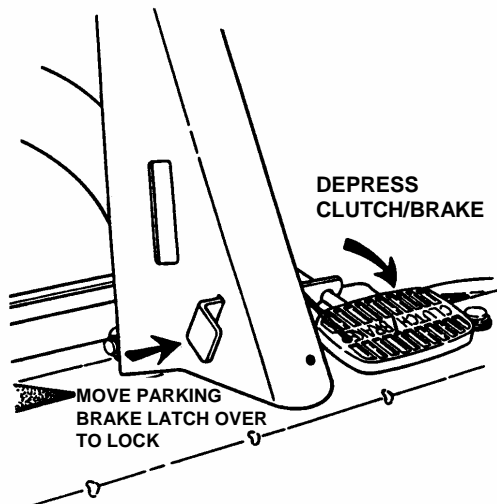

FIGURE 4.8

5. Measure the distance between end of clutch/brake cable and bottom of housing. Measurement should be no less than 1/2" and no greater than 3/4". See inset of Figure 4.9.

6. If measurement is less than 1/2" or greater than 3/4", loosen the two jam-nuts. See Figure 4.10. Hold the clutch/brake cable to the chain case bracket.

7. Adjust cable up or down using the jam-nuts to obtain a distance of 1/2" to 3/4" between end of clutch/brake cable (adjustment shown in inset of Figure 4.9) and bottom of housing. See Figure 4.9.
8. After adjustment is complete, securely tighten cable jam-nuts.

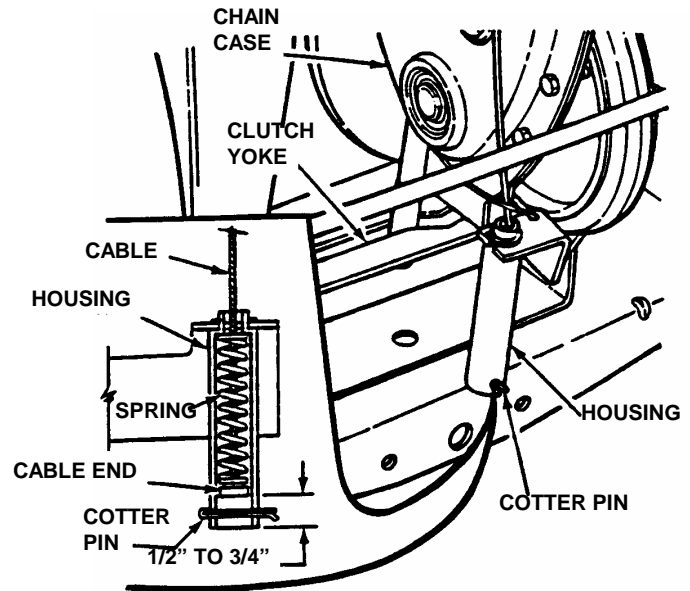

FIGURE 4.9

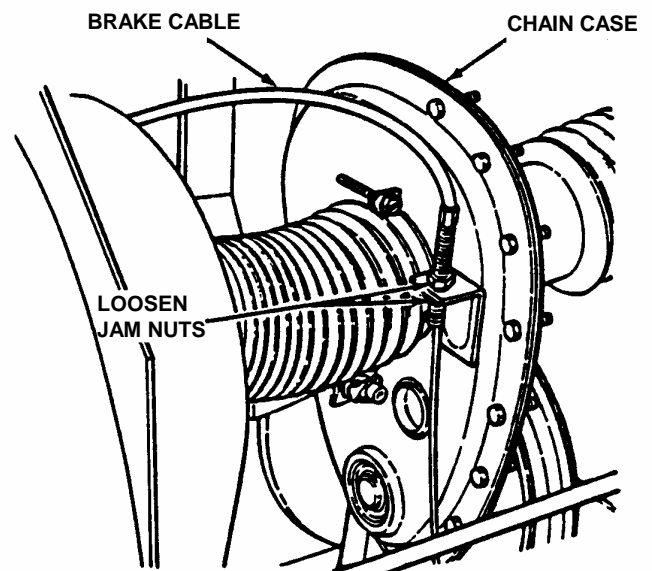

FIGURE 4.10

## Section 4 - ADJUSTMENTS & REPAIR

**WARNING**

DO NOT attempt any adjustments, maintenance, service or repairs with the engine running. STOP engine. STOP blade. Engage parking brake. Remove key. Remove spark plug wire from spark plug and secure away from plug. Engine and components are HOT. Avoid serious burns, allow all parts to cool before working on machine. Fuel Filler Cap and vent must be closed securely to prevent fuel spillage. DO NOT use a cutting blade that shows signs of excessive wear or damage on the Rear Engine Rider. On Rear Engine Riders equipped with a grass catcher attachment, the air lifts should be replaced when the blade is replaced.

### 4.4 MOWER BLADE REPLACEMENT

#### 4.4.1. BLADE WEAR LIMITS

1. Inspect blade frequently for signs of excessive wear or damage. See Figure 4.11.

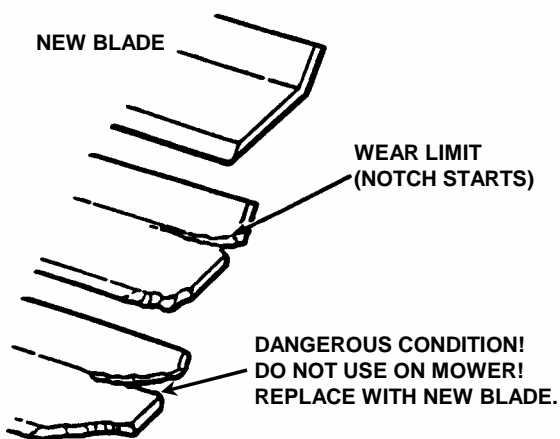

FIGURE 4.11

5. Inspect condition of blade. See Figure 4.11.
6. If blade is in good condition, sharpen at 22 to 28 degrees. DO NOT sharpen beyond existing cutting edge. See Figure 4.13.
7. Check blade balance after sharpening. If necessary, correct blade balance by grinding the heavy end of blade.
8. Reinstall blade. See Figure 4.12. Torque blade mounting bolts to recommended range of 30 to 40 ft. lbs.

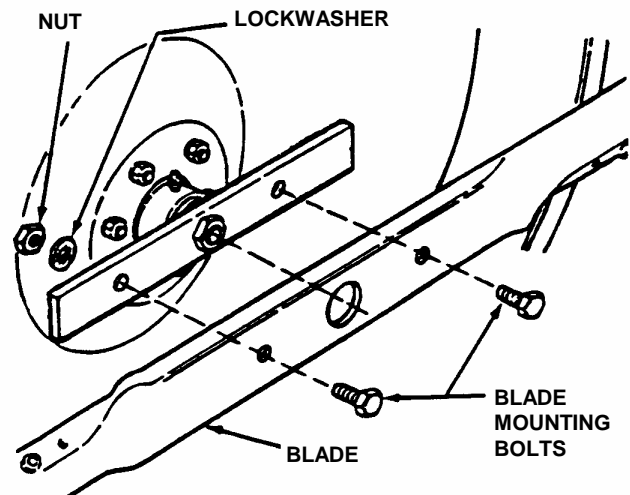

FIGURE 4.12

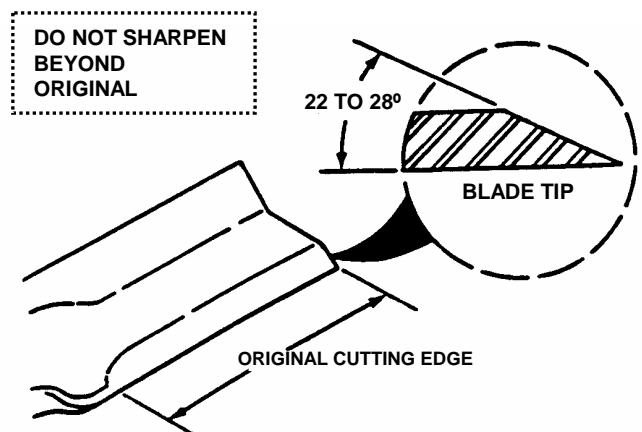

FIGURE 4.13

**WARNING**

Blades are extremely sharp and can cause severe injuries. Wear heavy leather gloves when working on or handling blades. DO NOT use blades that show signs of wear or damage.

#### 4.4.2. BLADE SHARPENING

1. Follow **WARNING** statement found on this page.
2. Check fuel level in tank. If over 3/4 full, remove tank. Refer to Section "REMOVING FUEL TANK". If 3/4 or less, proceed to next step.
3. Carefully stand Rear Engine Rider on rear bumper.
4. Remove blade. See Figure 4.12.

## Section 4 - ADJUSTMENTS & REPAIR

**WARNING**

**DO NOT** attempt any adjustments, maintenance, service or repairs with the engine running. **STOP** engine. **STOP** blade. Engage parking brake. Remove key. Remove spark plug wire from spark plug and secure away from plug. Engine and components are **HOT**. Avoid serious burns, allow all parts to cool before working on machine. Fuel Filler Cap and vent must be closed securely to prevent fuel spillage.

### 4.5 BLADE DRIVE BELT REPLACEMENT

Inspect mower drive belt as described in Section CHECK MOWER DRIVE BELT. Replace belt if signs of excessive wear and/or damage are present.

#### 4.5.1. BELT REMOVAL

1. Remove mower drive belt cover. Refer to Section on Drive Belt Cover Removal.
2. Remove old belt.

#### 4.5.2. BELT REPLACEMENT

1. Follow **WARNING** statement found on this page.
2. Check fuel level in tank. If over 3/4 full, remove tank. Refer to Section "REMOVING FUEL TANK". If 3/4 or less, proceed to next step.
3. Carefully stand Rear Engine Rider on rear bumper.
4. Route new belt through engine belt guide up to engine pulley. See Figure 4.14.

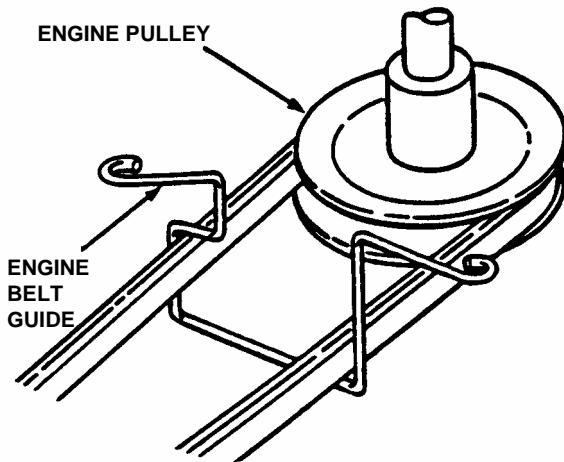

FIGURE 4.14

5. Move transmission shift lever to the neutral (N) position.
6. Rotate clutch yoke (clutch yoke shown in Figure 4.9) out with your hand and work belt between drive disc and rubber driven disc.
7. To clear the primary chain case, move transmission shift lever to the #5 position. Route belt around drive disc and into drive pulley belt groove.
8. Remove idler.
9. Route belt onto spindle pulley. Make sure belt is inside spindle belt guide and idler belt guide. Route belt as shown for the individual models shown in Figure 4.15.

10. Reinstall idler removed in Step 8. The idler belt guide tab should be positioned in the hole located on idler arm. Tighten idler pulley bolt securely.
11. Adjust belt guide. See Figure 4.15 for proper belt-to-belt guide clearances.
12. Check mower drive belt tension and adjust if necessary. Refer to Section "MOWER DRIVE BELT ADJUSTMENT".
13. Reinstall mower drive belt cover.

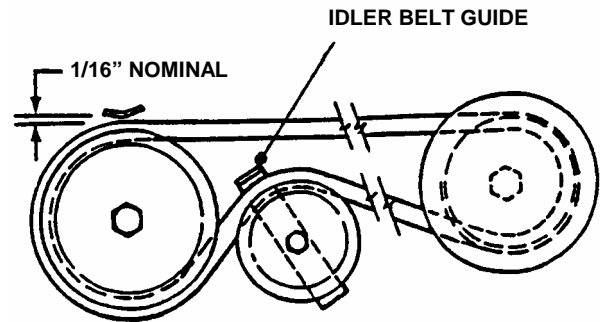

FIGURE 4.15

## Section 4 - ADJUSTMENTS & REPAIR

**WARNING**

DO NOT attempt any adjustments, maintenance, service or repairs with the engine running. Stop engine. Stop blade. Engage parking brake. Remove key. Remove spark plug wire from spark plug and secure away from plug. Engine and components are HOT. Avoid serious burns, allow all parts to cool before working on machine. Fuel Filler Cap and Vent must be closed securely to prevent fuel spillage. DO NOT attempt to service or charge the battery while it is installed on the machine.

### 4.6 BATTERY

#### 4.6.1. BATTERY REMOVAL

1. Carefully pull each side of battery cover away from ratchet fasteners and remove cover. See Figure 4.16.

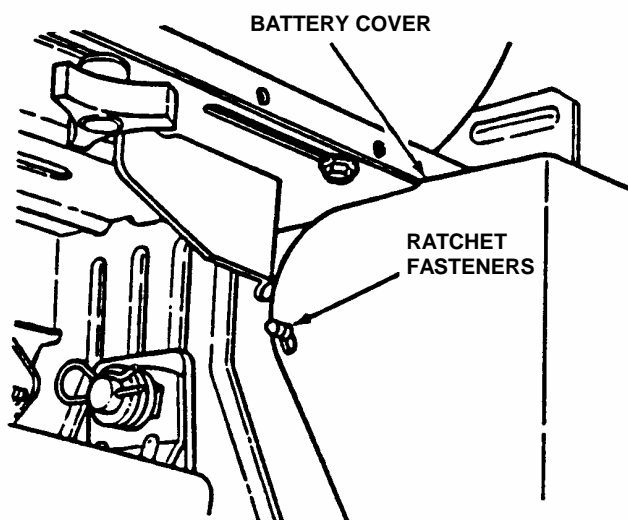

FIGURE 4.16

2. Slide battery from battery box to gain access to terminal cables.
3. Observe and note cable positions on battery. See Figure 4.17.
4. Disconnect cables from battery terminals, disconnecting BLACK (Negative) cable first. Retain mounting bolts and nuts.

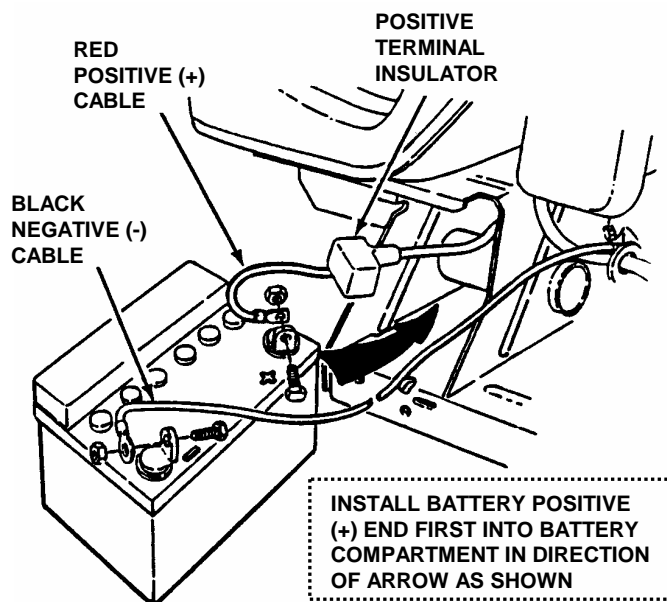

FIGURE 4.17



**WARNING**

Cables must be connected to battery terminals in the proper position as show in Figure 4.17. DO NOT attempt to charge battery while installed on the Rear Engine Rider. DO NOT use "BOOST" chargers on the battery.

#### 4.6.2. BATTERY INSTALLATION

1. Slide battery partially into battery housing.
2. Connect positive (+) cable (red) first, from wiring harness to the positive terminal (+) on battery using bolt and nut provided in hardware bag. Connect negative (-) cable (black) last, to negative terminal (-) on battery using bolt and nut. Apply a small amount of grease over terminals to prevent corrosion.
3. Insert battery completely into battery housing.
4. Reinstall positive terminal cover.
5. Reinstall battery cover. See Figure 4.16.

## Section 4 - ADJUSTMENTS & REPAIR

 **WARNING** 

The electrolyte (acid) produces a highly explosive gas. Keep all sparks, flame and fire away from area when charging battery or when handling electrolyte or battery. Electrolyte (acid) is a highly corrosive liquid. Wear eye protection. Wash affected areas immediately after having eye or skin contact with electrolyte (acid). Battery acid is corrosive. Rinse empty acid containers with water and mutilate before discarding. If acid is spilled on battery, bench, or clothing, etc., Flush with clear water and neutralize with baking soda. **DO NOT attempt to charge battery while installed on the RIDER. DO NOT use "BOOST" chargers on the battery.**

### 4.6.3. BATTERY SERVICE

1. Remove battery. Refer to Section "BATTERY REMOVAL".
2. Place battery in a well ventilated area on a level surface.
3. Using distilled water, refill cells as required to cover cell plates of which can also be visualized through the plastic battery case.
4. With cell caps removed, connect battery charger to battery terminals. Red to positive (+) terminal and black to negative (-) terminal.
5. Slow charge battery at 1 amp for 10 hours.
6. If battery will not accept charge or is partially charged after 10 hours of charging at 1 amp, replace with new battery.

### 4.6.4. BATTERY STORAGE

If mower is to be stored out of season on its rear bumper, it is recommended the battery be removed, charged and stored.

1. Remove battery. (Refer to Section BATTERY REMOVAL).
2. Perform battery service.
3. Bring battery to full charge, if required.
4. Store battery in an area away from the RIDER on a wood surface. **DO NOT STORE BATTERY ON A CONCRETE SURFACE.**

### 4.6.5. NEW BATTERY PREPARATION



1. Remove battery from carton.
2. Place battery in a well ventilated area on a level non-concrete surface.
3. Remove battery cell caps. Fill cells as required with electrolyte (purchased separately) to proper level. Fill to 3/16" above cell plates. Filling battery with electrolyte will bring the battery to 80% charged state.
4. With cell caps removed, connect battery charger to battery terminals; RED to positive (+) and BLACK to negative (-) terminal.

**IMPORTANT:** 3/16" above cell plates is the recommended level. **DO NOT** place anything in battery other than specified electrolyte.

 **WARNING** 

**DO NOT attempt to charge battery while installed on the Riding Mower. DO NOT use "BOOST" chargers on the battery. DO NOT OVERFILL!**

5. Slow charge the battery at 1 amp for 2 hours to bring the battery to full charge.
6. After charging, check level of electrolyte and add as needed to bring level to 3/16" above cell plates.
7. Reinstall cell caps.
8. Slide battery partially into battery housing.
9. Connect positive (+) cable (red) first, from wiring harness to the positive terminal (+) on battery using bolt and nut provided in hardware bag. Connect negative (-) cable (black) last, to negative terminal (-) on battery using bolt and nut. Apply a small amount of grease over terminals to prevent corrosion.
10. Insert battery completely into battery housing.
11. Reinstall battery cover. See Figure 4.16.

 **WARNING** 

**Shield the positive terminal with terminal cover located on battery harness. This prevents metal from touching the positive terminal which could cause sparks.**

### 4.6.6. BATTERY TESTING

There are two types of battery tests: Unloaded and Loaded. The unloaded test is the procedure that will be discussed. It's the simplest and most commonly used. An unloaded test is made on a battery without discharging current. To perform unloaded testing, check charge condition using either a hydrometer or voltmeter.

1. Using a voltmeter, voltage readings appear instantly to show the state of charge. Remember to hook the positive lead to the battery's positive terminal, and the negative lead to the negative terminal.
2. A hydrometer measures the specific gravity of each cell. The specific gravity tells the degree of charge; generally, a specific gravity of about 1.265 to 1.280 indicates full charge. A reading of 1.230 to 1.260 indicates the battery should be charged. The chart on the next page shows the charge level as measured by syringe float hydrometer, digital voltmeter and five ball hydrometer.

**(Battery Testing Chart on Next Page)**



## Section 4 - ADJUSTMENTS & REPAIR

### 4.6.6. BATTERY TESTING

Battery Condition Chart			
State of Charge	Syringe Hydrometer	Digital Voltmeter	Five Ball Hydrometer
100% Charged w/ Sulfate Stop	1.280	12.80v	Five Balls Floating
100% Charged	1.265	12.60v	Four Balls Floating
75% Charged	1.210	12.40v	Three Balls Floating
50% Charged	1.160	12.10v	Two Balls Floating
25% Charged	1.120	11.90v	One Ball Floating
0% Charged	Less than 1.100	Less than 11.80v	Zero Balls Floating

## SNAPPER REAR ENGINE RIDER ACCESSORIES

PART NO.	DESCRIPTION OF KIT	MODELS USED ON
6-0517	Wheel Weight (8" Wheels)	All Rear Engine Riders
6-0601	Smooth Start Clutch	All Rear Engine Riders
6-0697	Dump Cart	All Rear Engine Riders
6-1400	Gauge Wheel	All 33" Deck Rear Engine Riders
6-0794	Gauge Wheel	All 41" & 42" Deck Rear Engine Riders
6-0941	Single Bag Catcher	All 25" Deck Rear Engine Riders
6-0942	Single Bag Catcher	All 26" & 30" Deck Rear Engine Riders
6-0943	Single Bag Catcher	All 28" & 33" Deck Rear Engine Riders
6-0944	Single Bag Catcher	All 41" & 42" Deck Rear Engine Riders
6-0945	Twin Bag Catcher	All 41" & 42" Deck Rear Engine Riders
6-0946	Twin Bag Catcher	All 28" & 33" Deck Rear Engine Riders
6-0947	Bag-N-Wagon	All 28" & 33" Deck Rear Engine Riders
6-0948	Thatcherizer	All Series 7 & Newer Riders
6-0964	Wagon Cover	All 28" & 33" Deck Rear Engine Riders
6-1190	Weight (Front)	All Series 7 & Newer Riders
6-0959	Dozer Blade (36" Blade)	All Rear Engine Riders
6-0357	Tire Chains (Tires-16 x 6.50-8)	All Rear Engine Riders
6-0358	Tire Chains (Tires-16 x 4.80-8)	All Rear Engine Riders
6-1823	Ninja Recycling (Cover)	All 25" Deck Rear Engine Riders
6-1049	Recycling (Cover)	All 25" Deck Rear Engine Riders
6-1253	Ninja Recycling (Cover)	All 28" Deck Rear Engine Riders
6-1254	Ninja Recycling (Cover)	All 30" Deck Rear Engine Riders
6-1255	Ninja Recycling (Cover)	All 33" Deck Rear Engine Riders
6-1220	Ninja Recycling (Cover)	All 41" & 42" Deck Rear Engine Riders
6-1910	Utility Trailer	
6-1911	Aerator	
6-1912	Dethatcher	
6-1913	Lawn Sweeper	
6-1914	Dethatcher Kit	
6-1915	Lawn Roller	
6-1916	Broadcast Spreader	

# TROUBLESHOOTING

PROBLEM	PROBABLE CAUSE	CORRECTIVE ACTION
<b>Engine Will Not Start Using Recoil Starter</b>	1. Fuel tank empty.	1. Fill fuel tank with fresh fuel to proper level.
	2. Engine needs choking.	2. Move choke control to "CHOKE" position.
	3. Spark plug wire disconnected.	3. Place spark plug wire onto spark plug.
	4. Faulty parking brake, blade or ignition switch.	4. Contact authorized <b>SNAPPER</b> dealer.
	5. Park brake not engaged.	5. Engage park brake.
	6. Blown Fuse.	6. Replace with new 20 AMP fuse.
	7. Faulty interlock module.	7. Contact authorized <b>SNAPPER</b> dealer.
	8. Faulty parking brake or blade switch.	8. Contact authorized <b>SNAPPER</b> dealer.
	9. Ignition is in the OFF position.	9. Turn ignition switch to the RUN position.
<b>Engine Will Not Start Using Electric Starter</b>	1. Fuel tank empty.	1. Fill fuel tank with fresh fuel to proper level.
	2. Engine needs choking.	2. Move choke control to "CHOKE" position.
	3. Spark plug wire disconnected.	3. Place spark plug wire onto spark plug.
	4. Faulty parking brake, blade or ignition switch.	4. Contact authorized <b>SNAPPER</b> dealer.
	5. Park brake not engaged.	5. Engage park brake.
	6. Blown Fuse.	6. Replace with new 20 AMP fuse.
	7. Faulty interlock module.	7. Contact authorized <b>SNAPPER</b> dealer.
	8. Faulty parking brake or blade switch.	8. Contact authorized <b>SNAPPER</b> dealer.
	9. Ignition is in the OFF position.	9. Turn ignition switch to the START position.
	10. Battery is weak or dead.	10. Charge or replace with new battery.
	11. Battery cables loose, broken disconnected or corroded.	11. Clean and connect battery cables. If broken, replace with new battery cables.
	12. Faulty electric starter or starter solenoid.	12. Contact authorized <b>SNAPPER</b> dealer.
	13. Starter cable loose, broken or disconnected	13. Connect starter cable. If broken, replace with new starter cable.
	14. Electrical wiring harness disconnected or broken.	14. Connect or replace with new wiring harness.
<b>Engine Stalls After Running</b>	1. Operator not in seat.	1. Sit in operator's seat.
	2. Choke control in the "CHOKE" position.	2. Move choke control to "OFF" position.
	3. Fuel tank empty.	3. Fill fuel tank with fresh fuel to proper level.
	4. Engine air pre-cleaner and or air cleaner dirty.	4. Clean free of all debris.
	5. Spark plug defective or gap set improperly.	5. Service spark plug.
	6. Fuel filter restricted.	6. Replace fuel filter.
	7. Water, debris or stale fuel in fuel system.	7. Drain and clean fuel system.
<b>Engine Loses Power</b>	1. Excessive load on engine.	1. Lessen load.
	2. Engine air pre-cleaner or air cleaner dirty	2. Clean or replace filters.
	3. Spark plug faulty.	3. Service spark plug.
	4. Water, debris or stale fuel in fuel system.	4. Drain and clean fuel system. Replace filter.
	5. Debris build up on engine cooling screen.	5. Clean all debris from engine cooling screen.
<b>Engine Backfires When Turned To "STOP"</b>	1. Throttle control set too "FAST".	1. Set throttle control to "SLOW" and allow engine to idle. Then, turn key to "OFF".
<b>Excessive Vibration</b>	1. Damaged, out of balance or bent mower blades.	1. Service mower blade(s).
	2. Loose blade components.	2. Service and tighten loose parts.
	3. Loose or missing air lift (if equipped).	3. Replace air lifts. Tighten to proper torque.
	4. Lumpy or frayed belt	4. Replace belt.
	5. Bent Idler, stationary or spindle pulley	5. Replace pulley.

(Trouble Shooting Continued on Next Page)

# TROUBLESHOOTING

PROBLEM	PROBABLE CAUSE	CORRECTIVE ACTION
<b>Rider Will Not Move Loss Of Traction</b>	1. Drive disc worn or damaged.	1. Replace drive disc.
	2. Rubber drive disc is not tracking properly on drive disc.	2. Adjust rubber drive disc.
	3. Tapered axle bolt and nut missing.	3. Replace with <b>SNAPPER</b> tapered bolt & nut.
	4. Axle bearing seized.	4. Contact authorized <b>SNAPPER</b> dealer.
	5. Insufficient lubrication in chain case or transmission/differential.	5. Contact authorized <b>SNAPPER</b> dealer.
<b>Blade(s) Not Cutting</b>	1. Blade engagement lever in the "OFF" position.	1. Move lever to the "ON" position.
	2. Mower belt slipping.	2. Adjust or replace mower belt.
	3. Cutting blade is dull, worn or damaged.	3. Sharpen or replace cutting blade.
<b>Cutting Grass Improperly</b>	1. Uneven tire pressure.	1. Bring to proper pressure. 12 PSI front tire & 12 PSI rear tire.
	2. Cutting height too low or high.	2. Adjust cutting height.
	3. Engine speed too slow.	3. Move throttle control to "FAST" position.
	4. Forward speed too fast.	4. Move transmission shift lever to a slower speed.
	5. Terraced cut, side to side.	5. Adjust side to side level
	6. Excessive deck pitch, front to rear.	6. Adjust front to rear pitch.
	7. Cutting blade(s) dull or damaged.	7. Sharpen cutting edges or replace blade(s).
	8. Mower belt slipping.	8. Adjust tension or replace mower belt.
<b>Poor Grass Discharge</b>	1. Engine speed too slow.	1. Move throttle control to "FAST" position.
	2. Forward speed too fast.	2. Move transmission shift lever to a slower speed.
	3. Grass is wet.	3. Mow when grass is dry.
	4. Excessively dull, worn or damaged blade(s).	4. Service mower blade
	5. Build up of grass clippings and debris under deck.	5. Clean the underside of deck.
	6. Improper blade installed on deck.	6. Install proper <b>SNAPPER</b> blades.
<b>Oil Leaking</b>	1. Leaking chain case or differential plugs.	1. Verify plugs are not cracked & are in good shape. Check gaskets.
	2. Leaking engine block.	2. Contact authorized <b>SNAPPER</b> dealer.

## MAINTENANCE SCHEDULE

SUBJECT	SERVICE TO BE PERFORMED	REFERENCE PAGES	EACH USE	5 HOURS	25 HOURS	50 HOURS	100 HOURS	EACH SEASON
Engine	Check Oil Level	Page 6	X					
Engine	Initial Oil Change	Page 12		X				
Engine	Periodic Oil Change	Page 13				X*		
Air Pre-Cleaner	Service Sponge Pre-Cleaner Element	Engine Manual			X**			
Air Cleaner	Replace Element	Engine Manual.			X**			
Spark Plug	Replace Plugs	Engine Manual.					X	
Fuel Filter	Replace Filter	Page 16					X	
Engine Cooling System	Clean Shrouds & Fins	Engine Manual					X**	
Battery	Check Electrolyte	Page 23			X			X
Battery	Charge Battery	Page 23 & 24						X
Tires	Check Pressures	Page 6	X					
Drive Belts	Check For Wear And Tension	Pages 13, 17, 22			X			X
Mower Blades	Check For Wear And Damage	Pages 21			X			
Mower Deck	Clean Debris Accumulation	Page 14	X		X			X
Lubrication Points	Grease or Oil	Pages 14 & 15			X			X
Lubricate Chain Case & Transmission	Check Grease Level	Pages 15					X	X
Blade Brake Stopping Time	Check blade stopping for proper operation	Pages 9, 10 & 18	X					X
Clutch/Brake System	Check Clutch/Brake for proper operation	Page 7, 8, 18 – 20	X					X

\*Change oil every 25 hours when operating under heavy load or high temperatures.

\*\*Clean more often under dusty conditions or when air debris is present

## MAINTENANCE/REPLACEMENT PARTS

<b>MAINTENANCE PARTS</b>	
Engine Speed Control (Briggs Engine)	2-4155
Clutch/Brake Cable	2-9913
Brake Cable	2-2344
25" Cutter Blade (Standard - Not Air Lift Compatible)	3-5619
25" Cutter Blade (Standard - Air Lift Compatible)	1-9518
25" Cutter Blade (Mulching)	1-6967
25" Cutter Blade (Ninja - Quad Edge)	2-9143
28" Cutter Blade (Standard - Not Air Lift Compatible)	3-5635
28" Cutter Blade (Standard - Air Lift Compatible)	1-9515
28" Cutter Blade (Mulching)	1-6980
28" Cutter Blade (Ninja - Quad Edge)	2-6453
30" Cutter Blade (Standard - Not Air Lift Compatible)	N/A
30" Cutter Blade (Standard - Air Lift Compatible)	1-8069
30" Cutter Blade (Ninja - Quad Edge)	2-6565
Air Lift Kit (25" & 28" Decks)	6-0480
Air Lift Kit (30" Decks)	6-0735
Engine to Cutting Deck Belt	2-2252
Rubber Drive Disc	5-3103
Parts Manual for Rear Engine Rider Series 17 & 19	06073

# SNAPPER®

## 3 YEAR LIMITED WARRANTY

For three (3) years from purchase date for the original purchaser's residential, non-commercial use, **SNAPPER**, through any authorized **SNAPPER** dealer will replace, free of charge (except for taxes where applicable), any part or parts found upon examination by the factory at McDonough, Georgia, to be defective in material or workmanship or both.

For ninety (90) days from purchase date for the original purchaser's commercial, rental, or other non-residential use, **SNAPPER**, through any authorized **SNAPPER** dealer will replace, free of charge, any part or parts found upon examination by the factory at McDonough, Georgia, to be defective in material or workmanship or both.

All transportation costs incurred by the purchaser in submitting material to an authorized **SNAPPER** dealer for replacement under this warranty must be paid by the purchaser.

This warranty does not apply to engines and their components, and batteries, as these items are warranted separately. This warranty does not apply to parts that have been damaged by accident, alteration, abuse, improper lubrication, normal wear, or other cause beyond the control of **SNAPPER**. This warranty does not cover any machine or component part that has been altered or modified changing safety, performance, or durability.

Batteries have a one (1) year prorated warranty period with free replacement if required during the first ninety (90) days from the original purchase date. **SNAPPER** will not be responsible for any installation cost incurred. The battery warranty only covers original equipment batteries and does not cover damage to the battery or machine caused by neglect or abuse, destruction by fire, explosion, freezing, overcharging, improper maintenance, or use of improper electrolyte.

There is no other express warranty.

### DISCLAIMER OF WARRANTY

Implied warranties, including those of merchantability and fitness for a particular purpose, are limited to three (3) years from purchase date for the original purchaser's residential or other non-commercial use, and ninety (90) days from purchase for the original purchaser's commercial, rental or other non-residential use, and to the extent permitted by law, any and all implied warranties are excluded. This is the exclusive remedy. Liabilities for consequential damages, under any and all warranties are excluded.

Some states do not allow limitations on how long an implied warranty lasts, or do not allow the exclusion or limitation of incidental or consequential damages, so the above limitation or exclusion may not apply to you.

This warranty gives you specific legal rights, and you may also have other rights which vary from state to state.

**WARNING: THE USE OF REPLACEMENT PARTS OTHER THAN GENUINE SNAPPER PARTS MAY IMPAIR THE SAFETY OF SNAPPER PRODUCTS AND WILL VOID ANY LIABILITY AND WARRANTY BY SNAPPER ASSOCIATED WITH THE USE OF SUCH PARTS.**

**IMPORTANT:** Please fill out the attached **SNAPPER** Product Registration Card immediately and mail to:  
**Snapper's Product Registration Center, P.O. Box 1379, McDonough, Georgia 30253**

PRIMARY MAINTENANCE

# SNAPPER®

## vs. DIRT!

an illustration of how dirt can damage your engine & how reasonable maintenance can protect it!

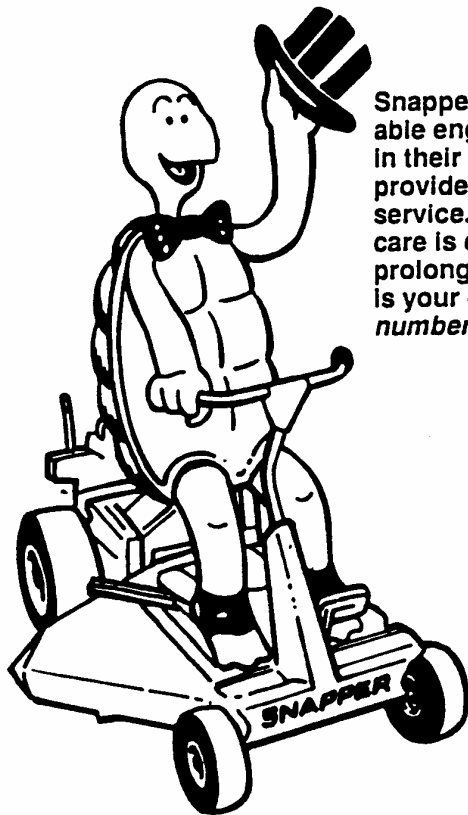
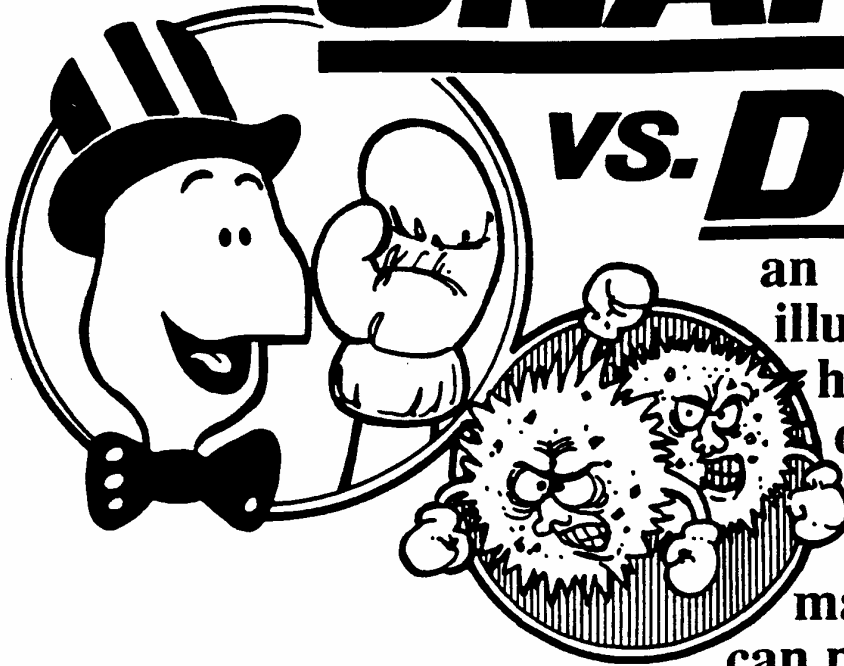

Snapper uses the best available engines and components in their products in order to provide long, satisfactory service. However, proper care is essential in prolonging engine life. Dirt is your engine's *enemy number 1!*

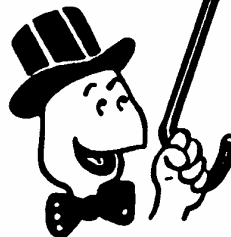

The engine on your Snapper product spends its entire life operating close to the ground at high speed creating a virtual storm of dust and dirt!

## PRIMARY MAINTENANCE

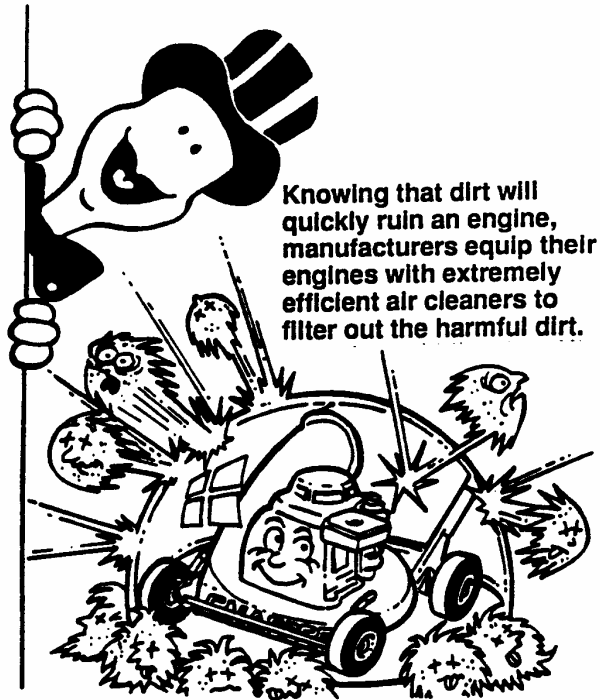
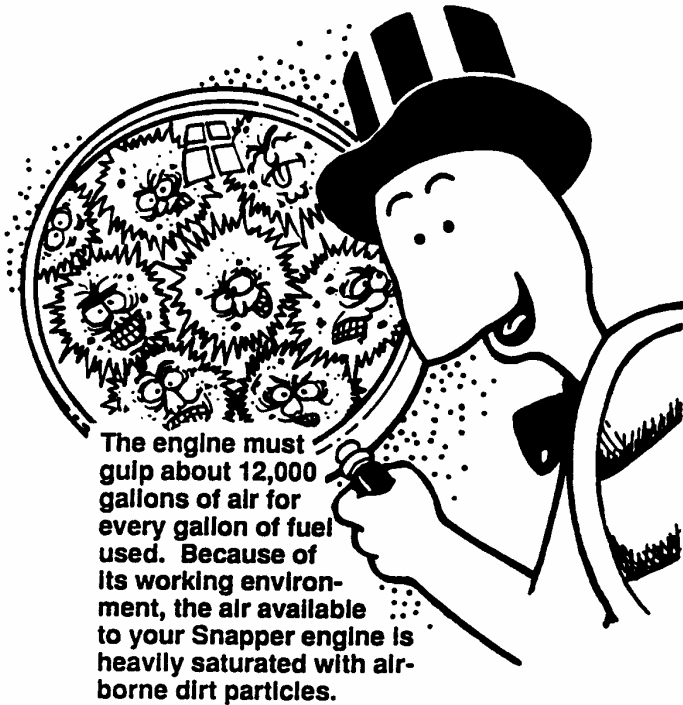

As the dirt particles are stopped, they build up and begin to clog the outside of the filter. This reduces the amount of air available to the engine and causes an over-rich fuel mixture which results in the following adverse effects:

An Improperly serviced, dirt clogged air cleaner will:

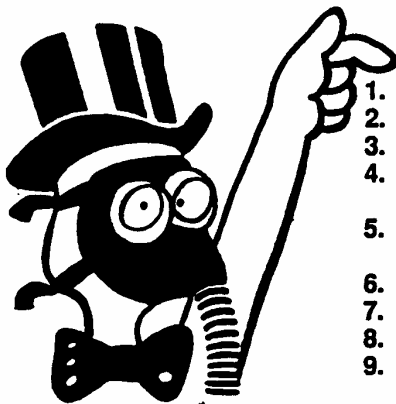

1. Increase fuel consumption
2. cause power loss
3. result in hard starting
4. create smoke from unburned fuel
5. produce carbon build-up internally
6. foul spark plug electrodes
7. score cylinder walls
8. burn valves
9. wear out the engine prematurely
10. COST YOU MONEY!

Damage caused by a poorly serviced air cleaner is not covered under the engine warranties. So, save yourself unnecessary expenses and undue aggravation by keeping the air cleaner properly serviced at the intervals specified in the engine owner's manual.

It doesn't take long to service an air cleaner. Follow the specific instructions in the engine owner's manual for the type filter used. Prevent dirt from falling into the carburetor intake when servicing your air cleaner. Make sure components are installed in correct sequence after servicing to prevent unfiltered air from entering the engine. Some servicing hints on several common types are:

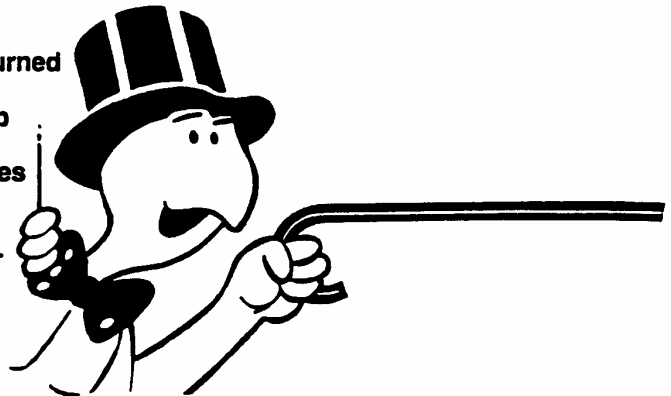



# PRIMARY MAINTENANCE

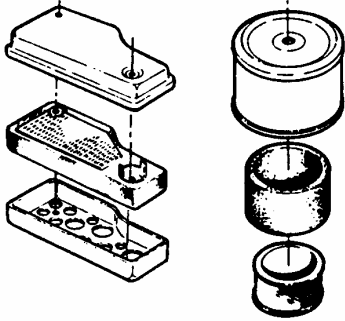

Generally, wash foam-type filters in a dishwashing detergent and water solution. Rinse and wring dry, then saturate with oil and squeeze out excess. *Failure to re-oil this type filter will ruin the engine.*

Clean paper elements by tapping lightly. Blowing with air will rupture paper elements.

Use a flashlight to detect clogged or torn paper elements - replace if damaged in any way.



Air is also needed to keep your engine cool. Dirt, dust & debris build up to restrict and clog cooling air intake screens and fins. Clean screens and fins at frequent intervals. The engine blower housing and shrouds should be removed at least once each season or more often under dry, dusty conditions for a thorough cleaning of fins.

Failure to keep external surfaces clean not only presents fire hazards, but causes overheating and resulting engine damages such as:

1. distorted valve guides
2. sticking valves
3. scuffed, scored cylinder walls
4. overspeeding
5. loss of power
6. complete failure of engine.

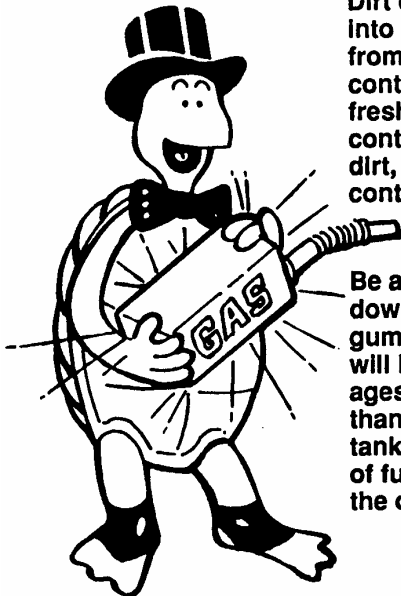
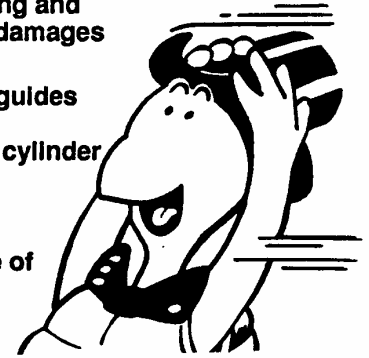

Dirt can also be introduced into an engine in dirty fuel from a contaminated container. Always use clean fresh fuel from a clean container to guard against dirt, sludge and water contamination.

Be aware that fuel breaks down in storage and forms gummy compounds which will block carburetor passages. Never use fuel more than 3 months old. Drain tank then run the engine out of fuel before storing during the off-season.



An engine must also have proper lubrication. All engines use some oil. On 4-cycle engines, **CHECK OIL LEVEL BEFORE EACH START-UP.** Wipe area clean around the oil check plug or dipstick opening to keep dirt from falling into the engine when checking the oil. Always check with the machine on a level surface. On engines with dipstick, keep the level up to, but not over, the **FULL** mark. When adding oil, allow time for all of the oil to flow down the fill tube to prevent a false reading when the level could actually be low and result in engine damage.

## PRIMARY MAINTENANCE

On 4-cycle engines with an oil level plug, don't be fooled into thinking the engine has sufficient lubricating oil if you can see "some" oil in the opening - the level should always be brought up to the point of overflowing at the top of the fill hole.

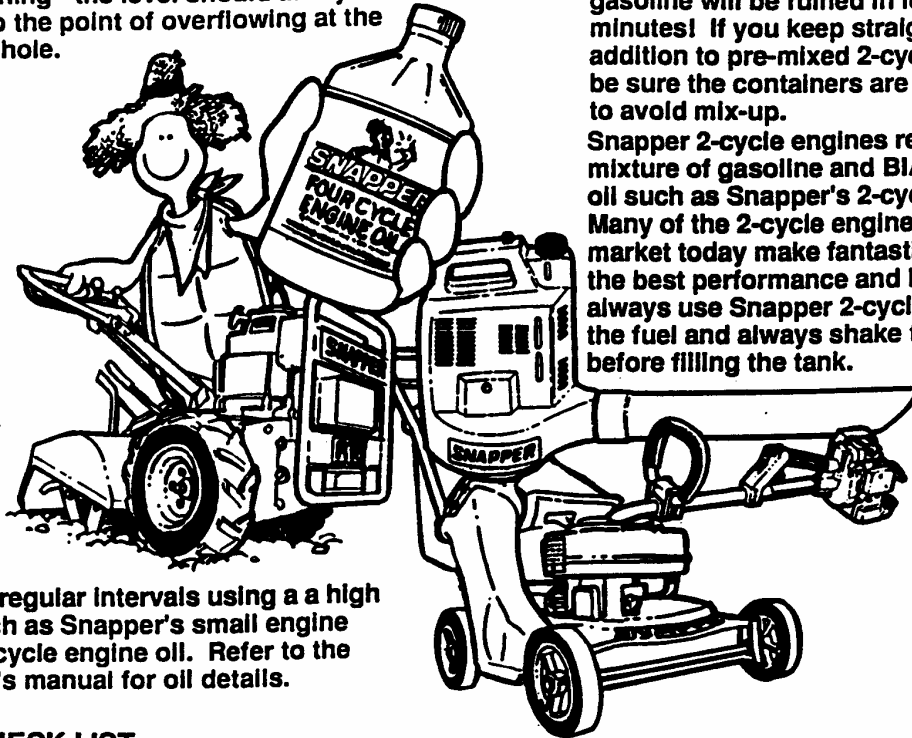
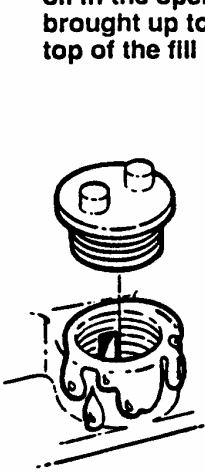

On 2-cycle engines, lubrication must be provided by an exact mixture of gasoline and 2-cycle air-cooled engine oil. A 2-cycle engine that is mistakenly run on straight gasoline will be ruined in less than 5 minutes! If you keep straight gasoline in addition to pre-mixed 2-cycle engine fuel, be sure the containers are clearly marked to avoid mix-up.

Snapper 2-cycle engines require a 32 to 1 mixture of gasoline and BIA certified TC-W oil such as Snapper's 2-cycle engine oil. Many of the 2-cycle engine oils on the market today make fantastic claims, but for the best performance and long engine life, always use Snapper 2-cycle oil. Pre-mix the fuel and always shake the container before filling the tank.

Change oil at regular intervals using a high quality oil such as Snapper's small engine formulated 4-cycle engine oil. Refer to the engine owner's manual for oil details.

### STARTING CHECK LIST

- |                              |  |
|------------------------------|--|
| 1. Engine Oil                | <ul style="list-style-type: none"> <li>• To full level (4-cycle)</li> <li>• Properly mixed with gas (2 cycle)</li> </ul>             |
| 2. Air Cleaner               | <ul style="list-style-type: none"> <li>• Clean and properly serviced</li> <li>• Full fresh clean gasoline</li> </ul>                 |
| 3. Fuel Tank                 | <ul style="list-style-type: none"> <li>• Fuel valve open</li> <li>• Cap vent open</li> <li>• Inline filter clean</li> </ul>          |
| 4. Choke                     | <ul style="list-style-type: none"> <li>• Operating properly</li> </ul>   |
| 5. Primer (on some engines)  | <ul style="list-style-type: none"> <li>• Used properly</li> </ul>  |
| 6. Safety Interlock Switches | <ul style="list-style-type: none"> <li>• In proper position</li> <li>• All wires properly connected</li> </ul>                       |
| 7. Switch & Blade Control    | <ul style="list-style-type: none"> <li>• Switch On</li> <li>• Blade control properly positioned on walk mower</li> </ul>             |
| 8. Spark plug                | <ul style="list-style-type: none"> <li>• Wire connected</li> <li>• Good connection</li> <li>• Start position</li> </ul>              |
| 9. Throttle control          |  |
| 10. Blade                    | <ul style="list-style-type: none"> <li>• Properly installed and torqued</li> <li>• Sharpened</li> </ul>                              |
| 11. Muffler                  | <ul style="list-style-type: none"> <li>• Good condition</li> <li>• Not clogged</li> <li>• Grass &amp; leaves cleaned away</li> </ul> |

Read and follow all safety instructions in safety booklets and manuals.

Keep in mind that dirt is your engine's *enemy* #1 both internally and externally! Internally, dirt will quickly ruin an engine and externally it will cause overheating and resulting internal damages. Damage caused by improper lubrication, poor air cleaner service or overheating due to dirt cannot be covered under warranty.

It only takes a few moments to service the engine (and equipment) on a routine basis but the rewards will be a quick starting, responsive engine that will provide long satisfactory service with minimum maintenance cost. The prestart checklist in the next column and instructions in your Snapper Operator's Manual are designated to help you keep your Snapper in top operating condition with minimum effort!



*Safety Instructions & Operator's Manual for*

# **SNAPPER<sup>®</sup>**

## **REAR ENGINE RIDING MOWER SERIES 19**

### **IMPORTANT**

Snapper products are built using engines that meet or exceed all applicable emissions requirements on the date manufactured. The labels on those engines contain very important emissions information and critical safety warnings. Read, Understand, and Follow all warnings and instructions in this manual, the engine manual, and on the machine, engine and attachments. If you have any questions about your Snapper product, contact your local authorized Snapper dealer or contact Snapper Customer Service at Snapper, McDonough, GA. 30253. Phone: (1-800-935-2967).



#### **WARNING:**

The engine exhaust from this product contains chemicals known to the State of California to cause cancer, birth defects or other reproductive harm.

COPYRIGHT © 1999  
SNAPPER INC.  
ALL RIGHTS RESERVED

**SNAPPER<sup>®</sup>** McDonough, GA., 30253 U.S.A.

MANUAL No. 7-1947 (REV. 1, 8/20/99)