

# INSTALLATION INSTRUCTIONS

REAR LIFT KIT  
MFG. NO. 1691003

1. Refer to figure 1 to identify parts in the kit. The reference letters are the same as figure 6.

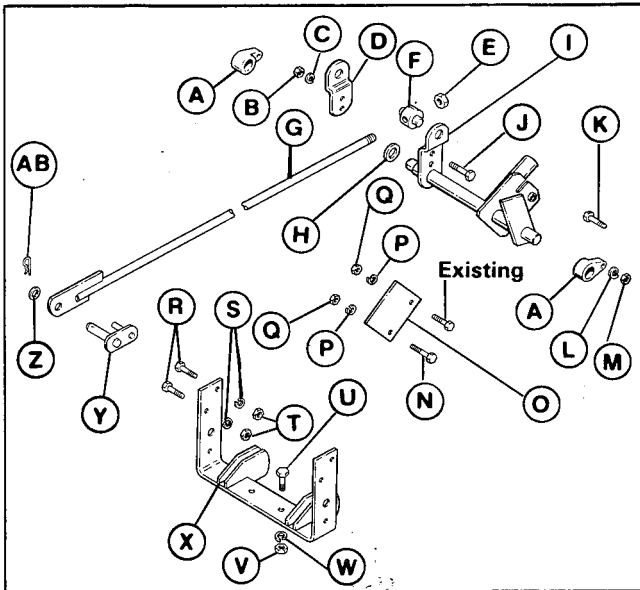

Figure 1.

- A. Bearing (2)
- B. Nut, 3/8 (2)
- C. Lockwasher, 3/8 (2)
- D. Lift Arm (1)
- E. Nut, Centerlock (1)
- F. Trunnion, Rear (1)
- G. Lift Rod (1)
- H. Washer, 1 (1)
- I. Lift Shaft (1)
- J. Capscrew, 3/8-16 x 1 (2)
- K. Capscrew, 5/16 (2)
- L. Lockwasher, 5/16 (2)
- M. Nut, 5/16 (2)
- N. Capscrew, 7/16-14 x 1-1/2 (1)
- O. Upstop Plate (1)
- P. Lockwasher, 7/16 (2)
- Q. Nut, 7/16 (2)
- R. Capscrew, 7/16-14 x 1-1/4 (4)
- S. Lockwasher, 7/16 (4)
- T. Nut, 7/16 (4)
- U. Capscrew, 1/2-13 x 1-1/4 (2)
- V. Lockwasher, 1/2 (2)
- W. Nut, 1/2 (2)
- X. Hitch (1)
- Y. Trunnion, Front (1)
- Z. Washer (1)
- AB. Clip (1)

FILE COPY

2. Install the lift rod (G, figure 1) as follows:

- a. Remove the tractor lower side panel (figure 2) on right-hand side by removing four screws.
- b. Remove the tunnel cover (figure 2) by removing two screws at rear, and loosening two screws at front (holes are slotted).
- c. Remove upper side panel (figure 2) by removing three screws.

- d. Insert lift rod (G, figure 1) from rear of tractor up to the tractor lift lever. The rear end of lift rod is shown in figure 6. Figure 3 shows the lift rod (G) as it is positioned in tractor.
- e. The cylinder (figure 3) is connected to the tractor lift lever. Remove the clip and pin, and disconnect the cylinder from the lift lever.
- f. Using the front trunnion (Y, figure 1), connect the cylinder and lift rod (G) to the tractor lift lever. (See figure 4.) Position cylinder and insert short leg of trunnion through it. Connect lift rod to long leg of trunnion. Be sure lift rod is positioned with flat side as shown.

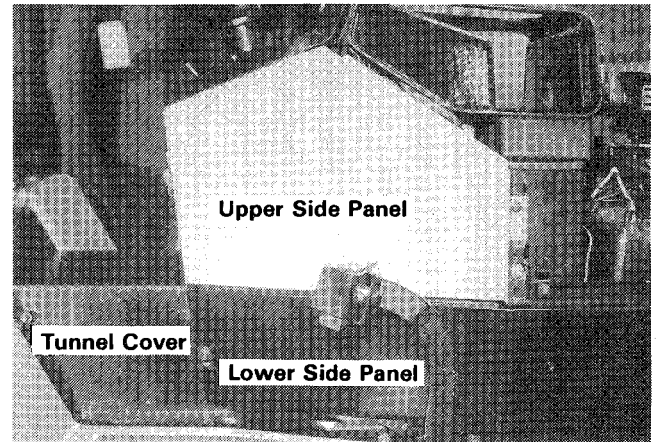

Figure 2.

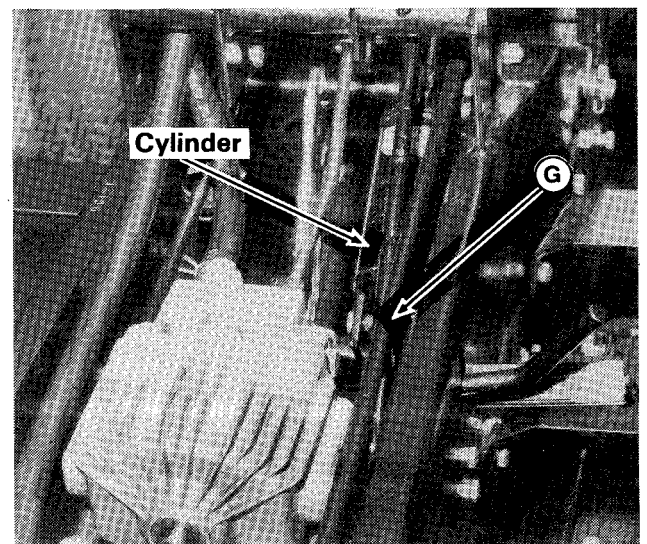

Figure 3.

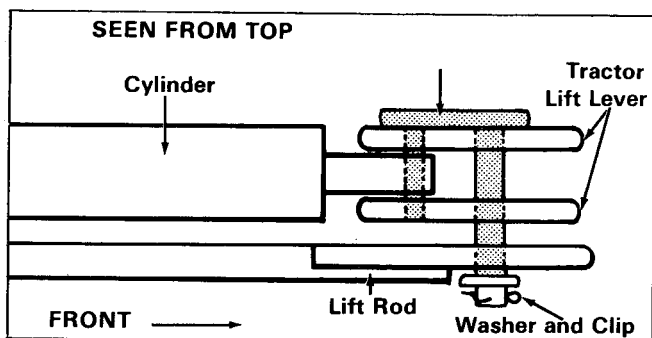

Figure 4.

3. If a rear PTO has been installed on the tractor, it is not necessary to install the upstop plate (O, figure 1). To install, proceed as follows:
  - a. Remove the rear-most screw from the transmission support (figure 5). This screw is used to install the plate.
  - b. Install the plate in mounting holes (C, figure 7) shown. Use 7/16-14 x 1-1/2" screw at front hole and 7/16-14 x 1-1/4" screw (from transmission support) at rear hole. Install lockwashers and nuts.

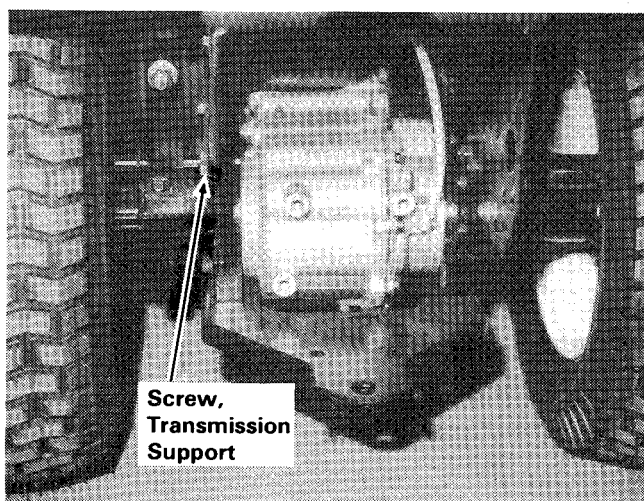

Figure 5.

4. Insert the lift shaft (I, figure 6) into position, place bearing (A) on to each end, and secure with capscrew, lockwasher and nut each side.
5. Position the rear trunnion (F) onto the lift rod (G) attaching the lift arm (D) with two 3/8-16 x 1" capscrews, 3/8" lockwashers and 3/8" nuts. Install centerlock nut (E) on end of lift rod.
6. Position the hitch (X) as shown in figure 6 and install two 7/16-14 x 1-1/4" capscrews (R), 7/16" lockwasher and 7/16" nuts each side. See mounting holes (B, figure 7).

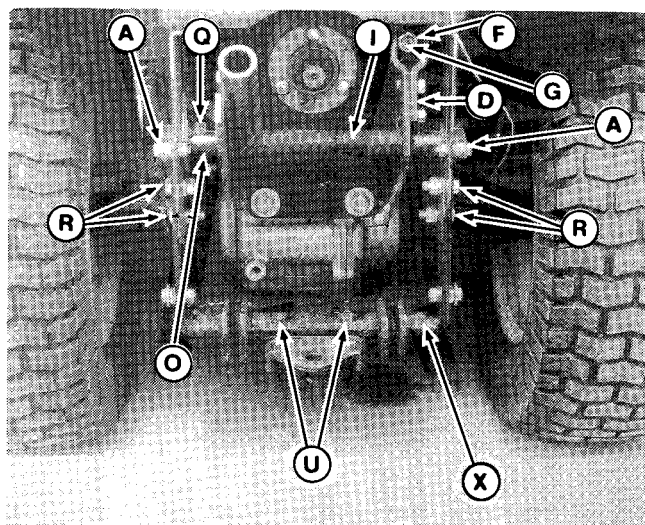

Figure 6.

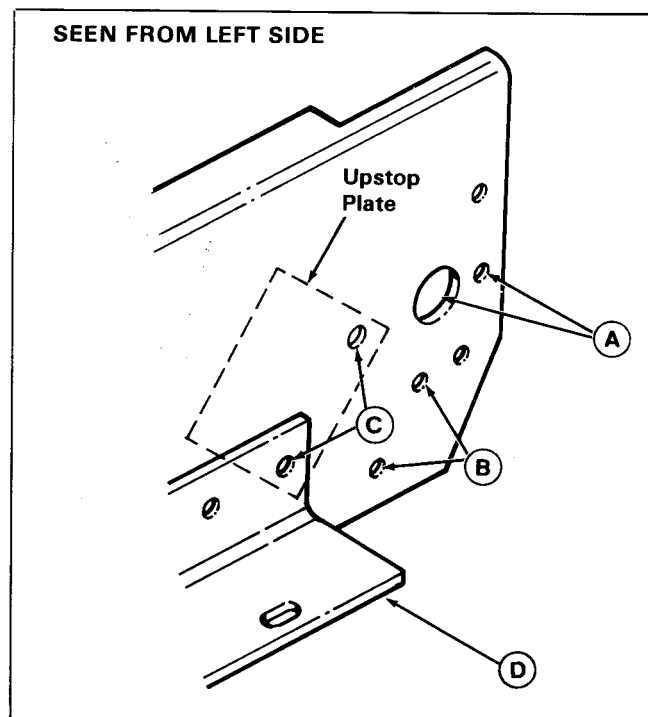

Figure 7.

- A. Lift Shaft Mtg. Holes
- B. Hitch Mtg. Holes
- C. Upstop Plate Mtg. Holes
- D. Transmission Support

7. From top, connect hitch (X) to drawbar with two 1/2-13 x 1-1/4 capscrews (U), 1/2" lockwashers, and 1/2" nuts.
8. Reinstall panels and cover (step 2). This completes installation.

# INSTALLATION INSTRUCTIONS

REAR LIFT KIT  
MFG. NO. 1691003

1. Refer to figure 1 to identify parts in the kit. The reference letters are the same as figure 6.

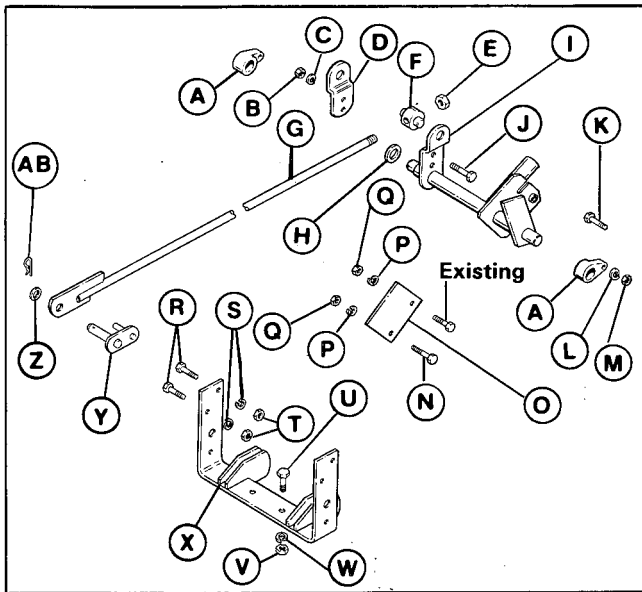
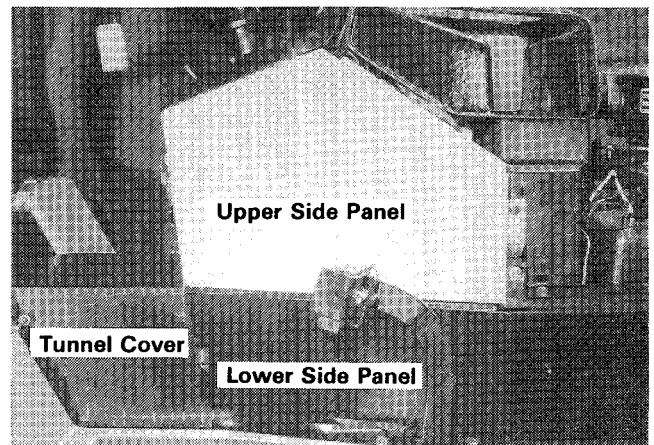

**Figure 1.**

- A. Bearing (2)
- B. Nut, 3/8 (2)
- C. Lockwasher, 3/8 (2)
- D. Lift Arm (1)
- E. Nut, Centerlock (1)
- F. Trunnion, Rear (1)
- G. Lift Rod (1)
- H. Washer, 1 (1)
- I. Lift Shaft (1)
- J. Capscrew, 3/8-16 x 1 (2)
- K. Capscrew, 5/16 (2)
- L. Lockwasher, 5/16 (2)
- M. Nut, 5/16 (2)
- N. Capscrew, 7/16-14 x 1-1/2 (1)
- O. Upstop Plate (1)
- P. Lockwasher, 7/16 (2)
- Q. Nut, 7/16 (2)
- R. Capscrew, 7/16-14 x 1-1/4 (4)
- S. Lockwasher, 7/16 (4)
- T. Nut, 7/16 (4)
- U. Capscrew, 1/2-13 x 1-1/4 (2)
- V. Lockwasher, 1/2 (2)
- W. Nut, 1/2 (2)
- X. Hitch (1)
- Y. Trunnion, Front (1)
- Z. Washer (1)
- AB. Clip (1)

2. Install the lift rod (G, figure 1) as follows:
  - a. Remove the tractor lower side panel (figure 2) on right-hand side by removing four screws.
  - b. Remove the tunnel cover (figure 2) by removing two screws at rear, and loosening two screws at front (holes are slotted).
  - c. Remove upper side panel (figure 2) by removing three screws.

- d. Insert lift rod (G, figure 1) from rear of tractor up to the tractor lift lever. The rear end of lift rod is shown in figure 6. Figure 3 shows the lift rod (G) as it is positioned in tractor.
- e. The cylinder (figure 3) is connected to the tractor lift lever. Remove the clip and pin, and disconnect the cylinder from the lift lever.
- f. Using the front trunnion (Y, figure 1), connect the cylinder and lift rod (G) to the tractor lift lever. (See figure 4.) Position cylinder and insert short leg of trunnion through it. Connect lift rod to long leg of trunnion. Be sure lift rod is positioned with flat side as shown.



**Figure 2.**

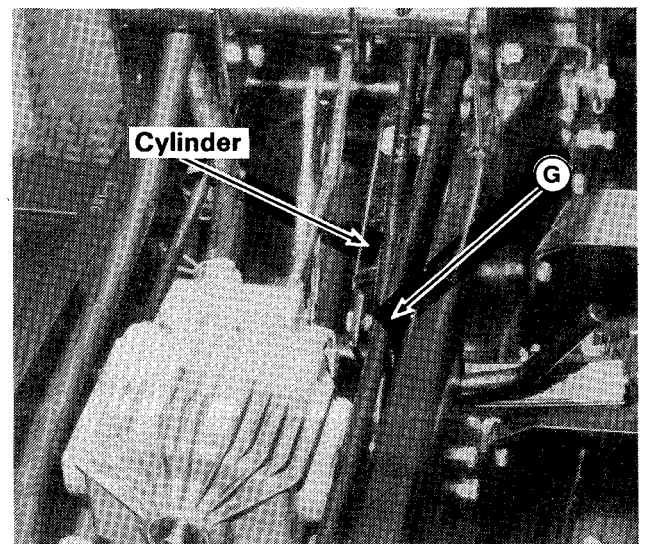

**Figure 3.**

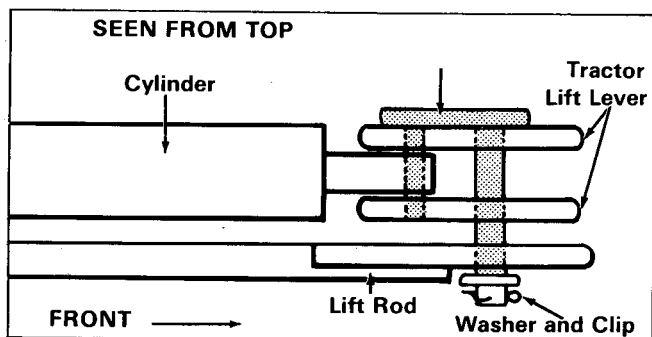

Figure 4.

3. If a rear PTO has been installed on the tractor, it is not necessary to install the upstop plate (O, figure 1). To install, proceed as follows:

- a. Remove the rear-most screw from the transmission support (figure 5). This screw is used to install the plate.
- b. Install the plate in mounting holes (C, figure 7) shown. Use 7/16-14 x 1-1/2" screw at front hole and 7/16-14 x 1-1/4" screw (from transmission support) at rear hole. Install lockwashers and nuts.

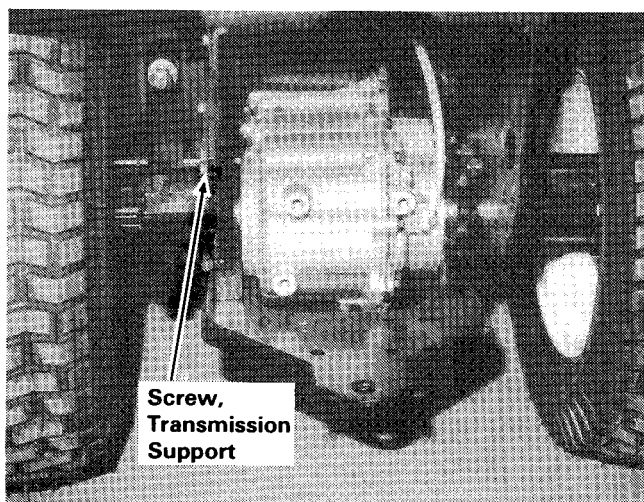

Figure 5.

4. Insert the lift shaft (I, figure 6) into position, place bearing (A) on to each end, and secure with capscrew, lockwasher and nut each side.
5. Position the rear trunnion (F) onto the lift rod (G) attaching the lift arm (D) with two 3/8-16 x 1" capscrews, 3/8" lockwashers and 3/8" nuts. Install centerlock nut (E) on end of lift rod.
6. Position the hitch (X) as shown in figure 6 and install two 7/16-14 x 1-1/4" capscrews (R), 7/16" lockwasher and 7/16" nuts each side. See mounting holes (B, figure 7).

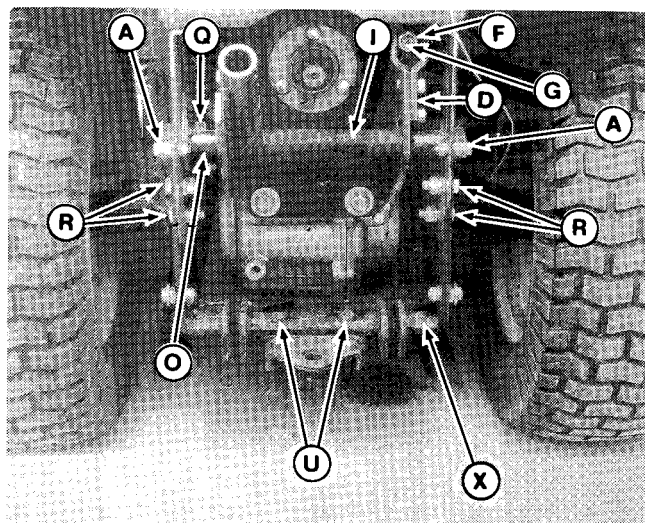

Figure 6.

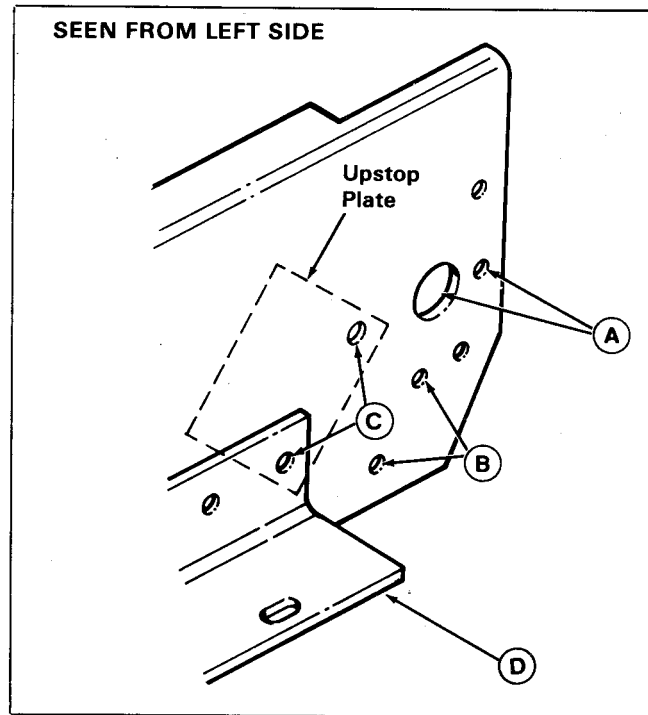

Figure 7.

- A. Lift Shaft Mtg. Holes
- B. Hitch Mtg. Holes
- C. Upstop Plate Mtg. Holes
- D. Transmission Support

7. From top, connect hitch (X) to drawbar with two 1/2-13 x 1-1/4 capscrews (U), 1/2" lockwashers, and 1/2" nuts.
8. Reinstall panels and cover (step 2). This completes installation.