

# WHITE<sup>®</sup>

by MTD

## OWNER'S GUIDE

GT-185  
GT-205

Model Number

836

HYDROSTATIC GARDEN  
TRACTORS

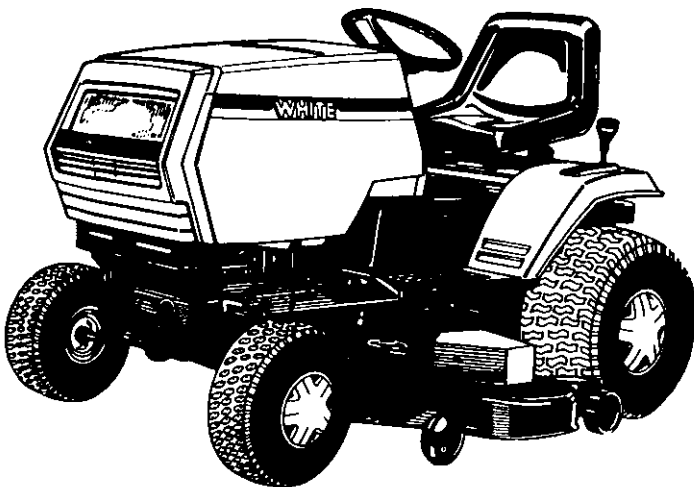



### IMPORTANT: READ SAFETY RULES AND INSTRUCTIONS CAREFULLY

**Warning:** This unit is equipped with an internal combustion engine and should not be used on or near any unimproved forest-covered, brush-covered or grass-covered land unless the engine's exhaust system is equipped with a spark arrester meeting applicable local or state laws (if any). If a spark arrester is used, it should be maintained in effective working order by the operator. In the State of California the above is required by law (Section 4442 of the California Public Resources Code). Other states may have similar laws. Federal laws apply on federal lands. A spark arrester for the muffler is available through your nearest engine authorized service dealer or contact the service department, P.O. Box 368022 Cleveland, Ohio 44136-9722.

MTD PRODUCTS INC. P.O. BOX 368022 CLEVELAND, OHIO 44136-9722

# IMPORTANT

## SAFE OPERATION PRACTICES

THIS SYMBOL POINTS OUT IMPORTANT SAFETY INSTRUCTIONS WHICH, IF NOT FOLLOWED, COULD ENDANGER THE PERSONAL SAFETY AND/OR PROPERTY OF YOURSELF AND OTHERS. READ AND FOLLOW ALL INSTRUCTIONS IN THIS MANUAL BEFORE ATTEMPTING TO OPERATE YOUR UNIT. WHEN YOU SEE THIS SYMBOL—  **HEED ITS WARNING.** 



### DANGER:

Your lawn mower was built to be operated according to the rules for safe operation in this manual. As with any type of power equipment, carelessness or error on the part of the operator can result in injury. This lawn mower is capable of amputating hands and feet and throwing objects. Failure to observe the following safety instructions could result in serious injury or death.



### I. GENERAL OPERATION

1. Read, understand, and follow all instructions in the manual and on the machine before starting. Keep this manual in a safe place for future and regular reference and for ordering replacement parts.
2. Only allow responsible individuals familiar with the instructions to operate the machine. Know controls and how to stop the machine quickly.
3. Do not put hands or feet under cutting deck or near rotating parts.
4. Clear the area of objects such as rocks, toys, wire, etc., which could be picked up and thrown by the blade. A small object may have been overlooked and could be accidentally thrown by the mower in any direction and cause injury to you or a bystander. To help avoid a thrown objects injury, keep children, bystanders and helpers at least 75 feet from the mower while it is in operation. Always wear safety glasses or safety goggles during operation or while performing an adjustment or repair, to protect eyes from foreign objects. Stop the blade(s) when crossing gravel drives, walks or roads.
5. Be sure the area is clear of other people before mowing. Stop machine if anyone enters the area.
6. Never carry passengers.
7. Disengage blade(s) before shifting into reverse and backing up. Always look down and behind before and while backing.
8. Be aware of the mower and attachment discharge direction and do not point it at anyone. Do not operate the mower without either the entire grass catcher or the chute guard in place.
9. Slow down before turning. Operate the machine smoothly. Avoid erratic operation and excessive speed.
10. Never leave a running machine unattended. Always turn off blade(s), place transmission in neutral, set park brake, stop engine and remove key before dismounting.
11. Turn off blade(s) when not mowing.
12. Stop engine and wait until blade(s) comes to a complete stop before (a) removing grass catcher or unclogging chute, or (b) making any repairs, adjusting or removing any grass or debris.
13. Mow only in daylight or good artificial light.
14. Do not operate the machine while under the influence of alcohol or drugs.
15. Watch for traffic when operating near or crossing roadways.
16. Use extra care when loading or unloading the machine into a trailer or truck. This unit should not be driven up or down a ramp onto a trailer or truck under power, because the unit could tip over, causing serious personal injury. The unit must be pushed manually on a ramp to load or unload properly.
17. Never make a cutting height adjustment while engine is running if operator must dismount to do so.
18. Wear sturdy, rough-soled work shoes and close-fitting slacks and shirts. Do not wear loose fitting clothes or jewelry. They can be caught in moving parts. Never operate a unit in bare feet, sandals, or sneakers.
19. Check overhead clearance carefully before driving under power lines, wires, bridges or low hanging tree branches, before entering or leaving buildings, or in any other situation where the operator may be struck or pulled from the unit, which could result in serious injury.

20. Disengage all attachment clutches, thoroughly depress the brake pedal, and shift into neutral before attempting to start engine.
21. Your mower is designed to cut normal residential grass of a height no more than 10". Do not attempt to mow through unusually tall, dry grass (e.g., pasture) or piles of dry leaves. Debris may build up on the mower deck or contact the engine exhaust presenting a potential fire hazard.



### II. SLOPE OPERATION

Slopes are a major factor related to loss of control and tip-over accidents which can result in severe injury or death. **All** slopes require extra caution. If you cannot back up the slope or if you feel uneasy on it, do not mow it.

For your safety, use the slope gauge included as part of this manual to measure slopes before operating this unit on a sloped or hilly area. If the slope is greater than 15° as shown on the slope gauge, do not operate this unit on that area or serious injury could result.

#### DO:

Mow up and down slopes, not across.  
Remove obstacles such as rocks, limbs, etc.  
Watch for holes, ruts or bumps. Uneven terrain could overturn the machine. **Tall grass can hide obstacles.**  
Use slow speed. Choose a low enough gear so that you will not have to stop or shift while on the slope. Always keep machine in gear when going down slopes to take advantage of engine braking action. Follow the manufacturer's recommendations for wheel weights or counterweights to improve stability.  
Use extra care with grass catchers or other attachments. These can change the stability of the machine.  
Keep all movement on the slopes **slow** and **gradual**. Do not make sudden changes in speed or direction. Rapid engagement or braking could cause the front of the machine to lift and rapidly flip over backwards which could cause serious injury.  
Avoid starting or stopping on a slope. If tires lose traction, disengage the blade(s) and proceed slowly **straight** down the slope.

#### DO NOT:

**Do not** turn on slopes unless necessary; then, turn slowly and gradually downhill, if possible.  
**Do not** mow near drop-offs, ditches or embankments. The mower could suddenly turn over if a wheel is over the edge of a cliff or ditch, or if an edge caves in.  
**Do not** mow on wet grass. Reduced traction could cause sliding.  
**Do not** try to stabilize the machine by putting your foot on the ground.  
**Do not** use grass catcher on steep slopes.



### III. CHILDREN

Tragic accidents can occur if the operator is not alert to the presence of children. Children are often attracted to the machine and the mowing activity. Never assume that children will remain where you last saw them.

1. Keep children out of the mowing area and in watchful care of an adult other than the operator.
2. Be alert and turn machine off if children enter the area.
3. Before and when backing, look behind and down for small children.

(continued on page 5)

USE THIS SHEET AS A GUIDE TO DETERMINE SLOPES WHERE YOU MAY NOT OPERATE SAFELY.

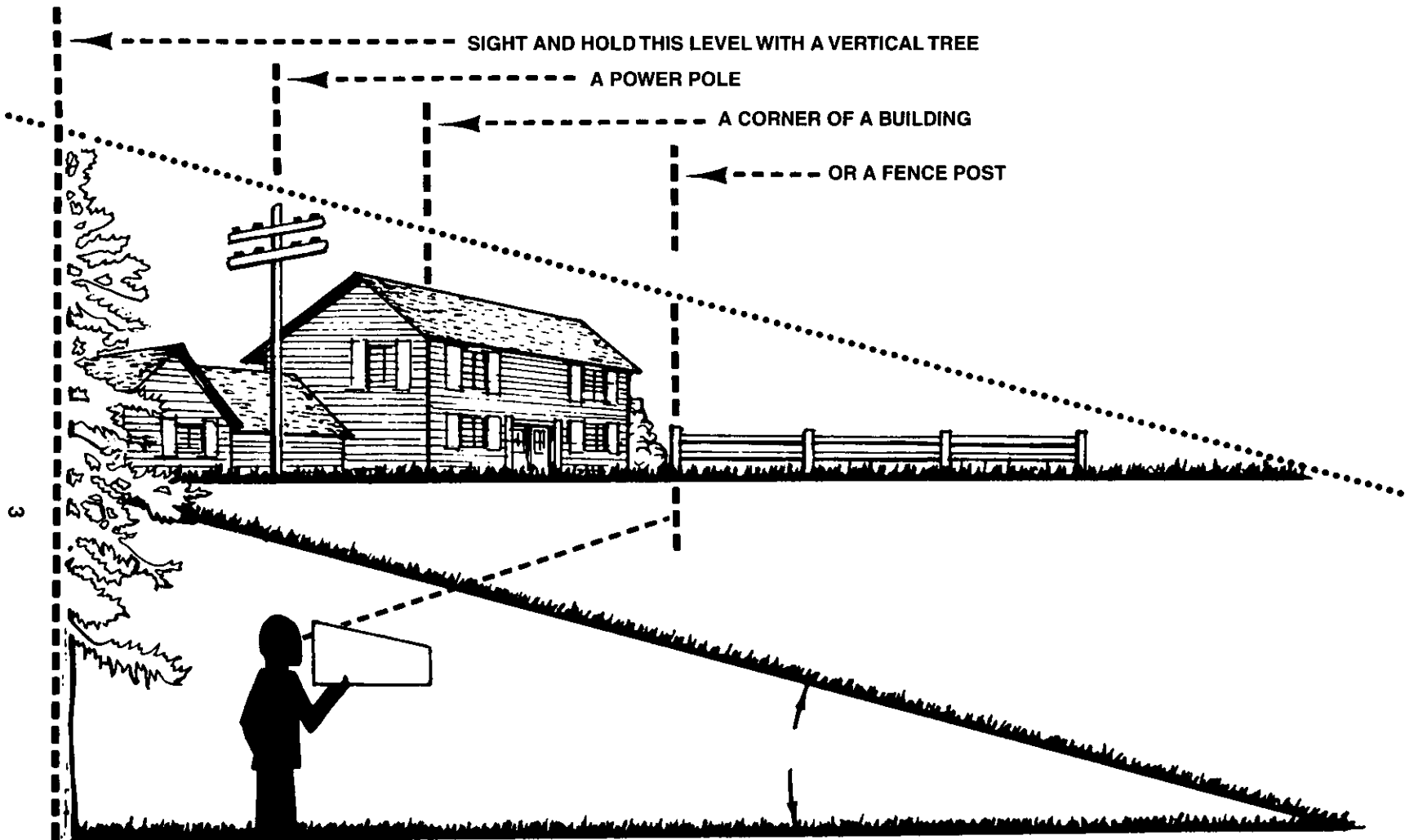

(Keep this sheet in a safe place for future reference.)

# SLOPE GAUGE



**WARNING**

Do not mow on inclines with a slope in excess of 15 degrees (a rise of approximately 2-1/2 feet every 10 feet). A riding mower could overturn and cause serious injury. If operating a walk-behind mower on such a slope, it is extremely difficult to maintain your footing and you could slip, resulting in serious injury.

Operate RIDING mowers up and down slopes, never across the face of slopes.

Operate WALK-BEHIND mowers across the face of slopes, never up and down slopes.

# CONTENTS OF HARDWARE PACK

Remove this sheet from your owner's manual and lay the hardware on the illustration for identification purposes. After assembly, keep the Slope Gauge which is on the reverse side of this sheet for future use.

(Hardware pack may contain extra items which are not used on your unit.)

Part numbers are shown in parentheses.)

## A ATTACHING THE DECK LINKS

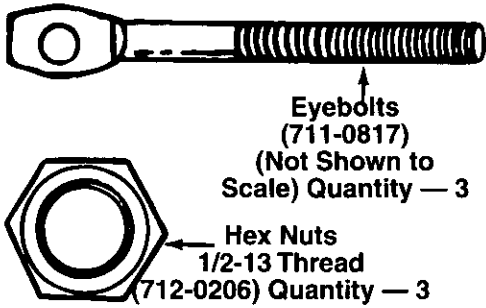

## C ATTACHING THE DECK

NOTE: This hardware may be assembled to the deck.

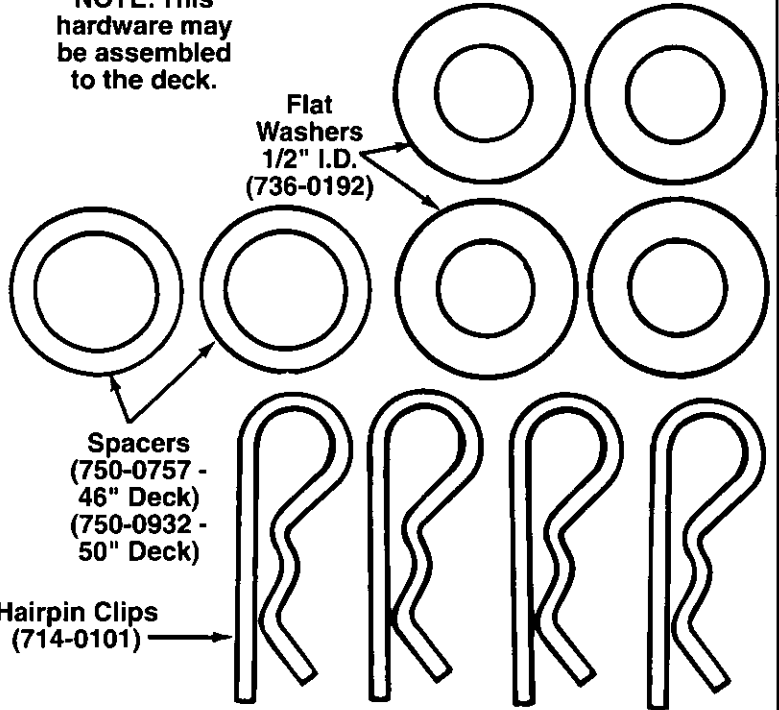

## D ATTACHING THE DECK WHEELS

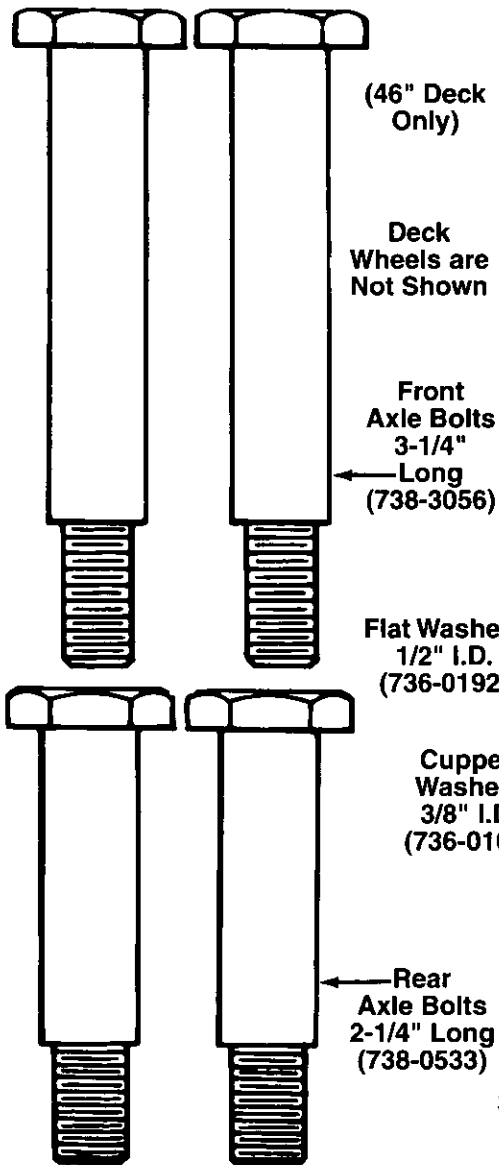

Flat Washers  
1/2" I.D.  
(736-0192)

Cupped Washers  
3/8" I.D.  
(736-0105)

Lock Washers  
3/8" I.D.  
(736-0169)

Hex Nuts  
3/8-16 Thread  
(712-0798)



Cut Along T. ne

4. Never carry children, even with the blades off. They may fall off and be seriously injured or interfere with the safe machine operation.
5. Never allow children under 14 years old to operate the machine. Children 14 years and over should only operate machine under close parental supervision and proper instruction.
6. Use extra care when approaching blind corners, shrubs, trees or other objects that may obscure your vision of a child or other hazard.
7. Remove key when machine is unattended to prevent unauthorized operation.

**IV. SERVICE**

1. Use extreme care in handling gasoline and other fuels. They are extremely flammable and the vapors are explosive.
  - a. Use only an approved container.
  - b. Never remove fuel cap or add fuel with the engine running. Allow engine to cool at least two minutes before refueling.
  - c. Replace fuel cap securely and wipe off any spilled fuel before starting the engine as it may cause a fire or explosion.
  - d. Extinguish all cigarettes, cigars, pipes and other sources of ignition.
  - e. Never refuel the machine indoors because fuel vapors will accumulate in the area.
  - f. Never store the fuel container or machine inside where there is an open flame or spark, such as a gas hot water heater, space heater or furnace.
2. Never run a machine inside a closed area.
3. To reduce fire hazard, keep the machine free of grass, leaves or other debris build-up. Clean up oil or fuel spillage. Allow machine to cool at least 5 minutes before storing.
4. Before cleaning, repairing or inspecting, make certain the blade and all moving parts have stopped. Disconnect the spark plug wire, and keep the wire away from the spark plug to prevent accidental starting.
5. Check the blade and engine mounting bolts at frequent intervals for proper tightness. Also, visually inspect blade for damage (e.g., excessive wear, bent, cracked). Replace with blade which meets original equipment specifications.

6. Keep all nuts, bolts and screws tight to be sure the equipment is in safe working condition.
7. Never tamper with safety devices. Check their proper operation regularly. Use all guards as instructed in this manual.
8. After striking a foreign object, stop the engine, remove the wire from the spark plug and thoroughly inspect the mower for any damage. Repair the damage before restarting and operating the mower.
9. Grass catcher components are subject to wear, damage and deterioration, which could expose moving parts or allow objects to be thrown. For your safety protection, frequently check components and replace with manufacturer's recommended parts when necessary.
10. Mower blades are sharp and can cut. Wrap the blade(s) or wear gloves and use extra caution when servicing blade(s).
11. Check brake operation frequently. Adjust and service as required.
12. Muffler, engine and belt guards become hot during operation and can cause a burn. Allow to cool down before touching.
13. Do not change the engine governor settings or overspeed the engine. Excessive engine speeds are dangerous.
14. Observe proper disposal laws and regulations. Improper disposal of fluids and materials can harm the environment and the ecology.
  - a. Prior to disposal, determine the proper method to dispose of waste from your local Environmental Protection Agency. Recycling centers are established to properly dispose of materials in an environmentally safe fashion.
  - b. Use proper containers when draining fluids. Do not use food or beverage containers that may mislead someone into drinking from them. Properly dispose of the containers immediately following the draining of fluids.
  - c. DO NOT pour oil or other fluids into the ground, down a drain or into a stream, pond, lake or other body of water. Observe Environmental Protection Agency regulations when disposing of oil, fuel, coolant, brake fluid, filters, batteries, tires and other harmful waste.

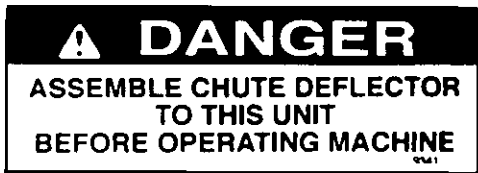
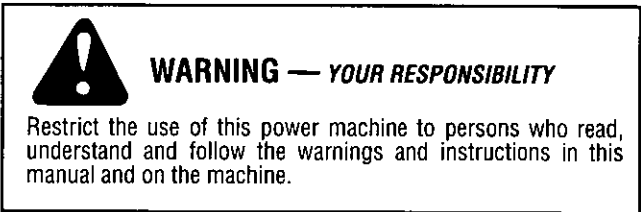
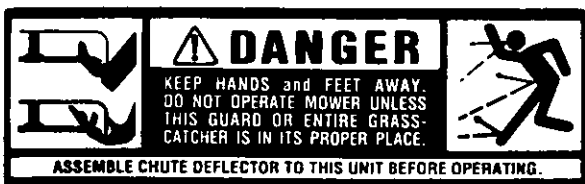

# UNPACKING

## TO REMOVE UNIT FROM CRATE

1. Remove all screws from the top of the crate using a 1/4" hex head socket or a flat blade screwdriver.
2. To remove ends, grasp top board on the end, and pull towards you in a downward motion.
3. Set panel aside to avoid tire punctures.
4. Repeat procedure for each side of the crate.
5. Remove and discard plastic bag which covers unit.
6. Loose parts (may include the owner's guide, steering wheel, battery fluid, chute deflector, etc.) are on the seat and wrapped in plastic. Carefully cut and remove the plastic wrap. Remove loose parts from the seat.
7. Remove the deck from beneath the tractor. Make certain brake and hydrostatic transmission are released. See the controls section of this manual for location of the parking brake release and the hydrostatic relief lever. Push unit off of the skid.
8. Remove page four from this manual and lay out the contents of the hardware pack according to the illustration for identification.

## ASSEMBLY INSTRUCTIONS

### BATTERY INFORMATION



- A. Battery acid must be handled with great care as contact with it can burn and blister the skin. It is also advisable to wear protective clothing (goggles, rubber gloves and apron) when working with it.\*
- B. Should battery acid accidentally splatter into the eyes or onto the face, rinse the affected area immediately with clean cold water. If there is any further discomfort, seek prompt medical attention.
- C. If acid spills on clothing, first dilute it with clean water, then neutralize with a solution of ammonia/water or baking soda/water.
- D. Since battery acid is corrosive, do not pour it into any sink or drain. Before discarding empty electrolyte containers, rinse them with a neutralizing solution.
- E. NEVER connect or disconnect charger clips to battery while charger is turned on as it can cause sparks.
- F. Keep all lighted materials (cigarettes, matches, lighters) away from the battery as the hydrogen gas generated during charging can be combustible.
- G. As a further precaution, only charge the battery in a well-ventilated area.

**\*Always shield eyes, protect skin and clothing when working near batteries.**



### DANGER

**Battery contains sulfuric acid. Refer to warning above.** Antidote: EXTERNAL—Flush with water. INTERNAL—Drink large quantities of water or milk. Follow with milk of magnesia, beaten eggs or vegetable oil. Call physician immediately. EYES: Flush with cool water for at least 15 minutes, then get prompt medical attention.

**Since batteries produce explosive gases, keep all lighted materials (cigarettes, lighters, matches, etc.) away.** Be sure to charge battery only in well-ventilated areas. Make certain venting path of battery (drain tube) is always open.

**KEEP BATTERIES  
OUT OF THE REACH OF CHILDREN!**

**IMPORTANT: After assembly, service engine with gasoline, and check oil level as instructed in the separate engine manual packed with your unit.**

**NOTE: Reference to right or left hand side of the unit is observed from the driver's seat, facing forward.**

### TOOLS REQUIRED FOR ASSEMBLY

- (1) 1/4" socket wrench or flat blade screwdriver
- (1) 1/2" wrench or socket wrench
- (1) 9/16" wrench or socket wrench
- (2) 7/16" wrenches or socket wrenches
- (1) Pair of pliers

## ACTIVATING AND CHARGING THE BATTERY

Do not activate battery (fill with battery acid) until battery is actually placed in service. Be certain to read previous warnings before activating the battery.

1. Lift the hood of the tractor. Remove the wing nuts from the hold-down rods which secure the battery cover to the battery. Refer to figure 14 on page 11. Remove the battery cover. Disconnect the positive cable from the positive terminal. Save the hardware.
2. Remove the battery from the tractor, paying attention to how the battery is placed in the unit, and how the drain tube (attached to the battery) is routed.
3. Activate the battery as instructed in the "Quick Start" brochure included with the battery fluid. Read instructions carefully.

**NOTE:** You can continue assembling the lawn tractor while battery is standing for 30 minutes (after filling with acid), and later while you are charging the battery.

**IMPORTANT:** To obtain the maximum life from your battery, it **MUST BE CHARGED** prior to initial use.

**CHARGE THE BATTERY** after the 30 minute standing period. Use a 12-volt automotive type battery charger to charge the battery at 6 AMPS for one hour before installation.

**NOTE:** If you charge the battery at a lower AMP rate, use a hydrometer to make sure the battery is completely charged. The hydrometer should read 1.260 minimum. **DO NOT CHARGE AT MORE THAN 6 AMPS.**

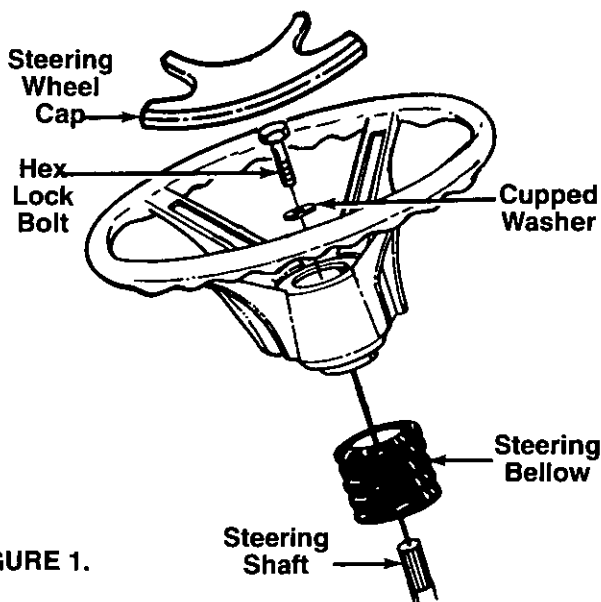

FIGURE 1.

## STEERING WHEEL INSTALLATION (Hardware A)

1. The hardware for attaching the steering wheel has been packed inside the steering wheel. Carefully pry off the steering wheel cap and remove the hardware.
2. Remove the steering bellow from the lift lever on the right hand side of tractor. Place steering bellow over the steering shaft extending through the dash. See figure 1.

**NOTE:** If the openings on each end of the steering bellow are two different sizes, the smaller end goes down against the dash of the tractor.

3. With the wheels of the tractor pointing straight forward, place the steering wheel over the steering shaft, positioning steering wheel as desired.
4. Place the washer with the cupped side down over the steering shaft. Secure with hex lock bolt. See figure 1.
5. Place the steering wheel cap over the center of the steering wheel and seat it with your hand.

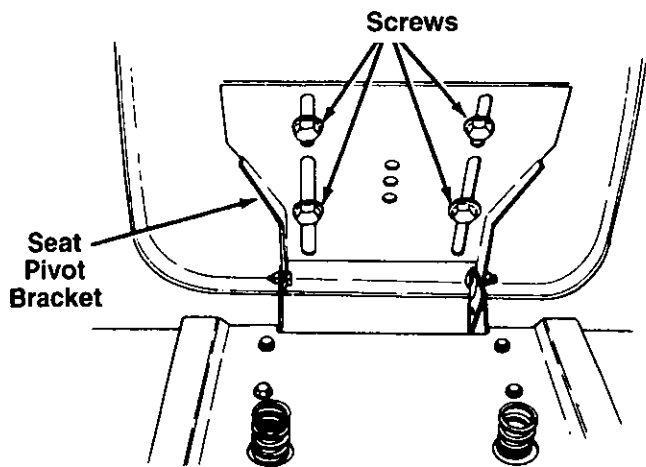

### ← SEAT ASSEMBLY

Turn seat around if it is facing backwards, or remove from box. Remove the four screws from the bottom of the seat. Place the seat in position against the seat pivot bracket, lining up the slotted holes in the pivot bracket with the holes in the seat. Select desired position for the seat, and secure with the four screws. See figure 2.

FIGURE 2.

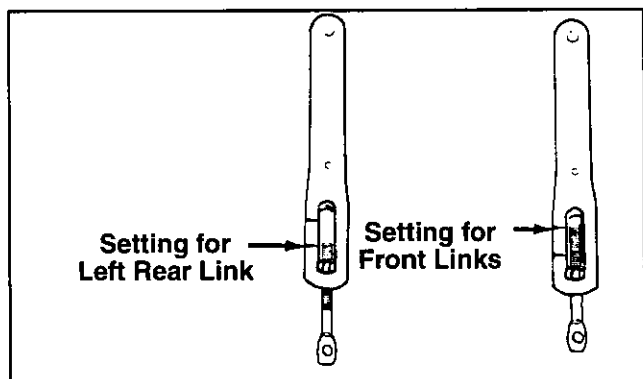

### ATTACHING THE DECK LINKS (Hardware A)

The three adjustable deck links have been shipped unassembled. Attach as follows.

1. Start 1/2" hex nuts on eyebolts provided. Insert the hex nuts and eyebolts into the adjustable lift links as shown in figure 3.
2. Thread eyebolts into the lift links and hex nuts. The left rear link should be adjusted so the eyebolt is to the lower mark as shown. The two front links should be adjusted to the higher mark.

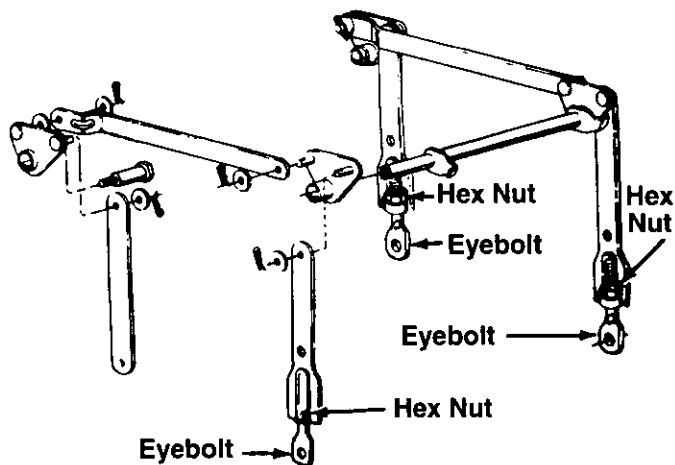

FIGURE 3.

### ATTACHING THE CUTTING DECK (Hardware C)

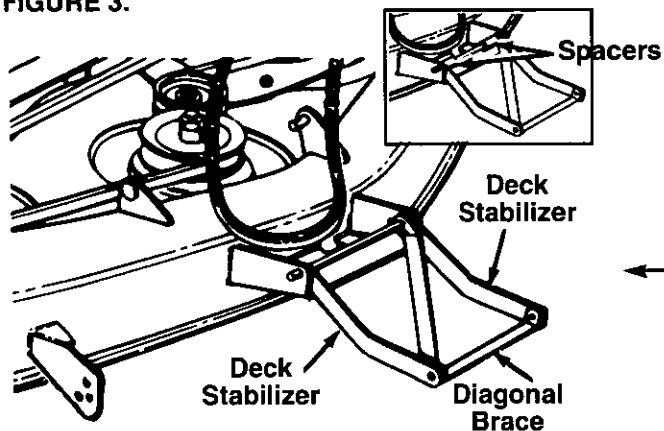

FIGURE 4.

1. Move the tractor lift handle all the way back to the full raised position. Turn the tractor steering wheel all the way to the left.
2. The two deck stabilizers and the diagonal brace which are attached to the front of the deck are folded back over the deck for shipping purposes. Unfold them at this time. See figure 4.



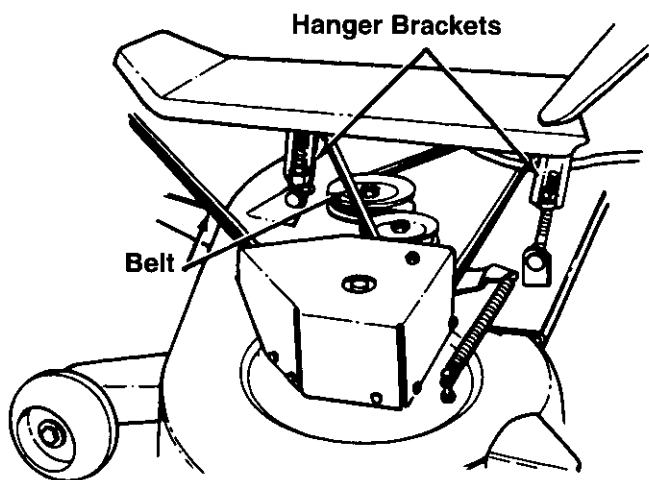

FIGURE 5.

**NOTE:** If the hardware for attaching the deck is assembled to your deck, remove the hairpin clips and flat washers from each deck bracket. Remove the spacers from the rod which is through the deck stabilizer by removing the hairpin clips and sliding out the rod. Replace the rod and hairpin clips. See figure 4, inset.

3. Slide the deck under the tractor from the right side as you lift the stabilizers and diagonal brace over the right front wheel.

4. Move tractor lift handle forward to the lowest position.

5. Attach the four tractor hanger brackets to the deck as follows. The left front tractor hanger bracket goes through the center of the V-belt. See figure 5. Attach the rear hanger brackets first, then the front, using four flat washers and hairpin clips.

6. Disassemble the front cross bar from the tractor by removing two hairpin clips. Use the cross bar to attach the deck stabilizers, the diagonal brace and two spacers to the tractor frame.

**46" Deck:** Use the rear set of holes.

**50" Deck:** Use the forward set of holes.

Secure with the two hairpin clips just removed. See figure 6.

7. Place the deck belt around the engine pulley and idler pulley.

8. Check all belt guards for clearance. The belt guards must be between 1/16" and 1/8" away from the belt when the PTO lever or switch is in the engaged or on position (be certain to disengage the PTO lever after checking).

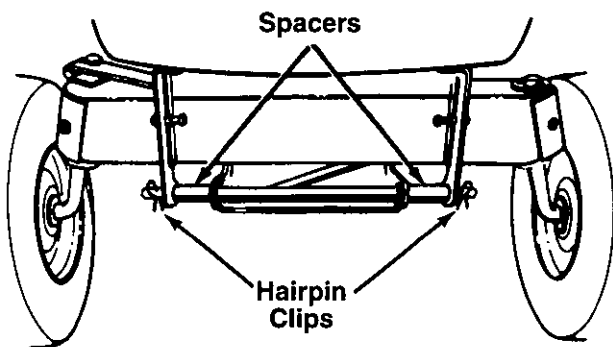

FIGURE 6.

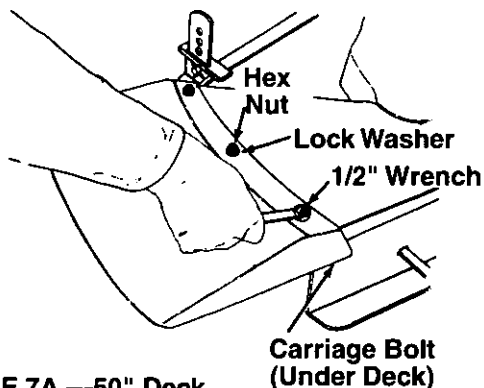

FIGURE 7A.—50" Deck

## ATTACHING THE CHUTE DEFLECTOR



**WARNING:** Do not operate the tractor unless the chute deflector has been properly installed.

Remove the bolts, nuts and cupped washers which are attached to the deck next to the chute opening. Place the chute deflector in position as shown in figure 7A or 7B. Secure with hardware just removed.

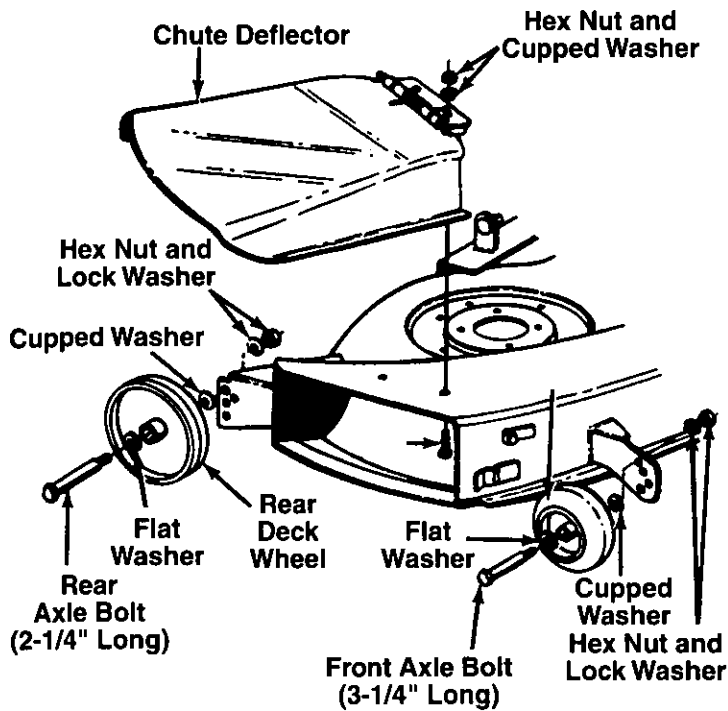

FIGURE 7B.—46" Deck

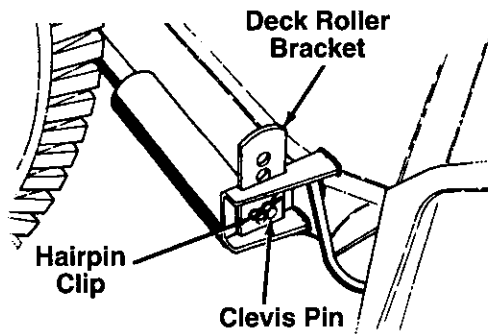

FIGURE 8.—50" Deck Only

## ATTACHING THE DECK WHEELS (Hardware D)

(46" Deck Only)

If the deck wheels are not already attached, attach the wheels to the deck as follows. All wheels must be placed in the same relative position.

**Front Wheels:** Front axle bolts are the longer bolts. Front deck wheels have a rounded surface.

**Rear Wheels:** Rear axle bolts are the shorter bolts. Rear deck wheels are flatter.

Place flat washer 1/2" I.D. on axle bolt, then the deck wheel and cupped washer (crowned side of washer goes against the wheel). See figure 7. Secure to deck with lock washer and hex nut. Tighten securely. Assemble remaining wheels in same manner.

## ATTACHING THE DECK ROLLER

(50" Deck Only)

Remove the hairpin clips and clevis pins from each end of the deck roller. Insert the deck roller brackets up through the brackets provided on the rear of the deck. Attach with clevis pins and hairpin clips just removed, using the same hole location on each side of the deck. See figure 8.

## TIRE PRESSURE

The tires on your unit may be over-inflated for shipping purposes. Reduce the tire pressure before operating the unit. Check the side wall of the tires for proper inflation pressure.



**WARNING: Maximum tire pressure under any circumstances is 30 p.s.i. Equal tire pressure should be maintained on all tires.**

## LEVELING THE DECK

After attaching the deck to the tractor, check to be certain it is adjusted properly.

1. Check tire pressure in all four tires. See sidewall of tire for recommended inflation pressure.
2. Make certain all deck wheels or both ends of the deck roller are mounted in same relative hole locations.
3. Place the tractor on a level surface.
4. 46" Deck: Lower the deck until it reaches the ground. All four deck wheels should reach the ground at the same time.
5. Both Decks: Place the deck approximately 1" above the ground. Check to be certain the distance from the bottom edge of the deck to the ground is the same on both sides of the deck.

If adjustment is necessary, adjust the deck links on the left side of the deck as follows.

1. Make certain the PTO is disengaged. Remove the hairpin clip and washer from the weld bolt. Thread eyebolt up or down the link as necessary, and reassemble.

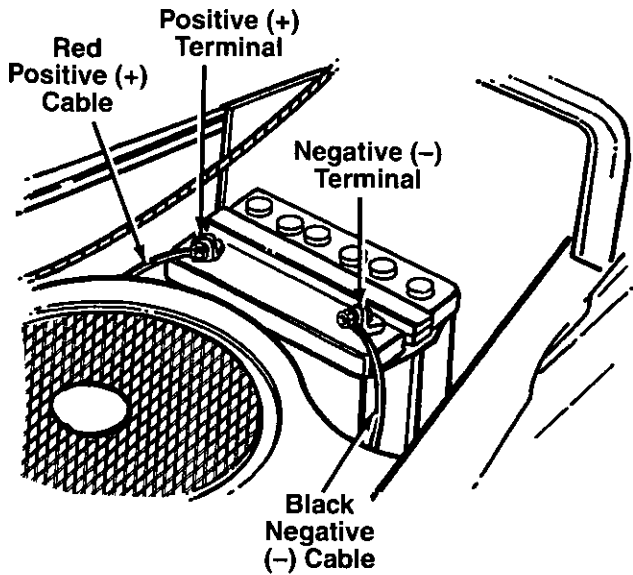

FIGURE 9.

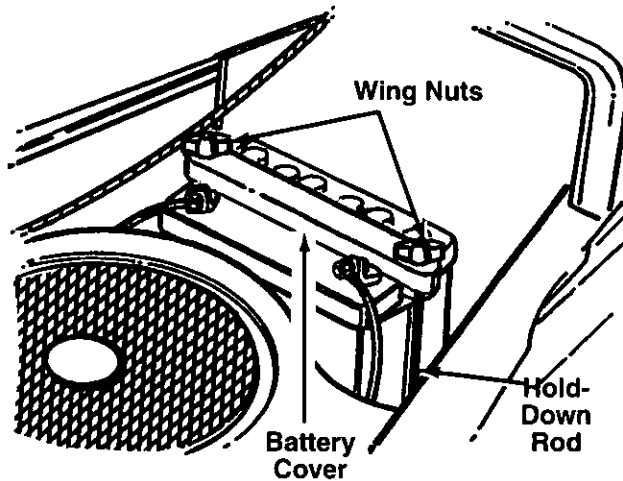

FIGURE 10.

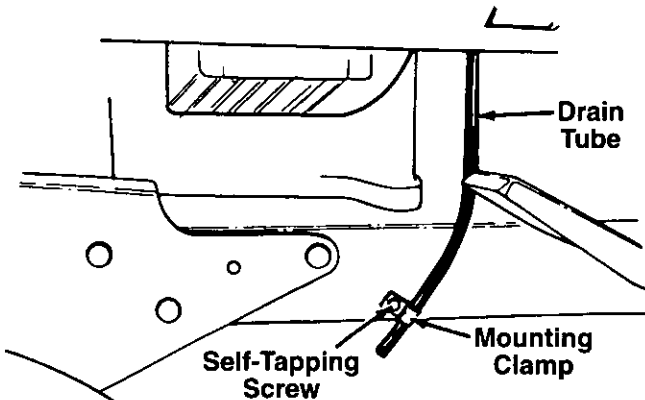

FIGURE 11.

2. Check to be certain the front of the deck is 1/4" to 3/8" lower than the rear of the deck. If it is not, adjust the two front links to obtain this distance.

### FINAL ASSEMBLY

1. Make certain all nuts and bolts are tightened securely.

### INSTALLING THE BATTERY

**NOTE:** The positive battery terminal is marked Pos. (+). The negative battery terminal is marked Neg. (-).

1. Place the battery on the battery plate with the terminals toward the front of the tractor.
2. Attach the positive cable (heavy red wire) to the positive battery terminal (+) with hex bolt and hex nut. See figure 9. Slide the rubber boot down over the positive terminal.
3. Remove the hex bolt and nut from the negative cable. Attach the negative cable (heavy black wire) to the negative battery terminal (-) with the bolt and nut.
4. Place the black plastic battery cover in position over the hold-down rods. Secure with wing nuts. See figure 10.

**NOTE:** It may be necessary to pull up on the hold-down rods in order to start the wing nuts.

5. Route the battery drain tube over to the left side of the tractor. Loosen the self-tapping screw which secures the mounting clamp. See figure 11. Slip the end of the drain tube into the mounting clamp. Tighten the self-tapping screw to secure the clamp. Do not overtighten which could collapse the drain tube.

**NOTE:** The vented battery allows any gases or liquid from the battery to be drained onto the ground.

6. Trim end of drain tube if more than 1 inch extends below the frame.

# CONTROLS

## IGNITION SWITCH

The ignition switch is located on the dashboard. The engine is started by turning the key to the **START** position. When the engine is running, leave the key in the **ON** position. To stop the engine, turn the key to the **OFF** position. See figure 13.



**WARNING: Remove the key from the tractor when the tractor is not in use to prevent accidental starting.**

## THROTTLE CONTROL

The throttle control is located on the left side of the dashboard and is used to regulate the engine speed. See figure 13. The engine should be operated from 3/4 to full throttle (**FAST**) when operating any equipment that uses the tractor engine as a source of power such as the mowing deck, snow thrower or rotary tiller.

## CHOKE CONTROL

The choke control is located on the right side of the dashboard and is operated manually. Details for the choke operation are covered in the separate engine manual packed with your unit. See figure 13.

## POWER TAKE-OFF (PTO) CONTROL SWITCH

The power take-off control switch operates the front electric PTO clutch. Pull the switch knob to engage ("**RUN**"), or push the knob to disengage ("**OFF**") the PTO clutch. (See figure 16.)

## IGNITION/LIGHT SWITCH

To prevent accidental starting and/or battery discharge, remove the key from the ignition switch when the tractor is not in use.

To start engine insert key into ignition switch and turn clockwise to the **START** position. Release key to the **ON** position once engine has fired. The lights are controlled by the ignition switch. After the tractor is running, turn the key counterclockwise to the **LIGHTS ON** position.



**WARNING: To prevent accidental starting and/or battery discharge, remove the key from the ignition switch when the tractor is not in use.**

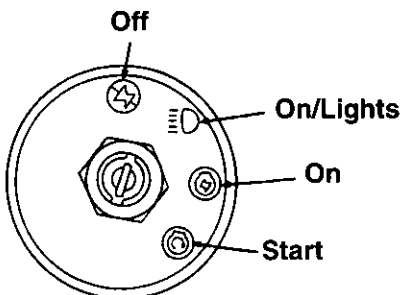

FIGURE 12.

## AMMETER

The ammeter registers the rate of battery charge or discharge. The ammeter will register on the discharging side when starting the engine. It should register on the opposite side (charging) when the engine is running in the fast position until the battery is completely charged. With a fully charged battery or with the engine idling, the ammeter will not show a charge. See figure 13.

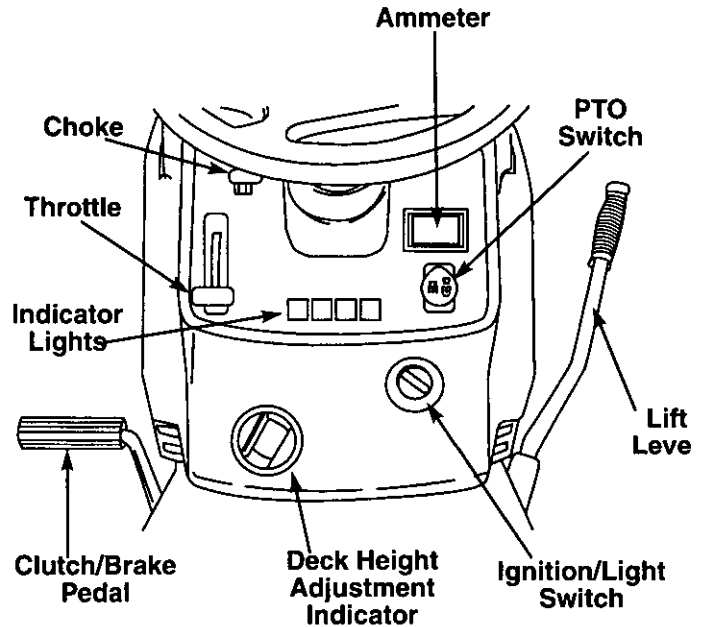

FIGURE 13.

## HYDROSTATIC CONTROL LEVER

The hydrostatic control lever is located on top of the fender on the left side of the tractor. This single control lever, connected to the hydrostatic transmission, controls both the speed and direction of the tractor. Infinite speed control is achieved by moving the control lever forward or backward. The farther forward or backward you move the control lever, the faster you will travel. Pulling the control lever into neutral (**N**) area will stop the tractor. To increase rear wheel torque (pulling power), move the control lever towards neutral (**N**) position. The lawn tractor responds similar to shifting to a lower gear with a gear type transmission. See figure 14.

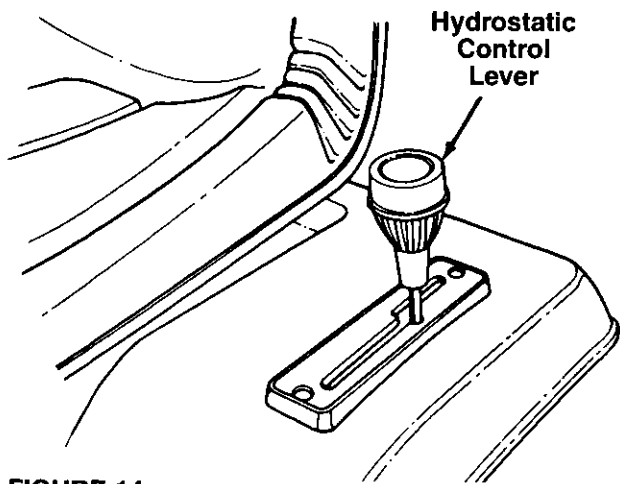

FIGURE 14.

### CLUTCH-BRAKE PEDAL

The clutch-brake pedal is located on the left side of the tractor. See figure 13. Depressing the pedal disengages the engine from the hydrostatic transmission and applies the brake.

**NOTE:** The clutch-brake pedal must be depressed to start the engine.

### PARKING BRAKE

To set the parking brake, depress the clutch-brake pedal and pull up the parking brake knob. It will stay in the raised position. To release the parking brake, depress and release the clutch-brake pedal. See figure 15.

**NOTE:** The parking brake must be set if the operator leaves the seat with the engine running.

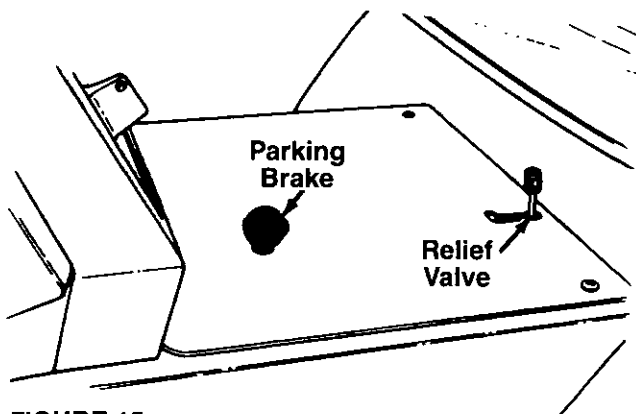

FIGURE 15.

### RELIEF VALVE

A hydrostatic relief valve is provided so the unit can be moved without the engine running. The lever which operates the relief valve is located on the console. See figure 16.

To operate the relief valve, place the hydrostatic control lever in neutral, release the parking brake, push the lever forward and to the right to lock. Be certain to release the lever by pushing it to the left before operating the engine.

### POWER TAKE-OFF (PTO) SWITCH

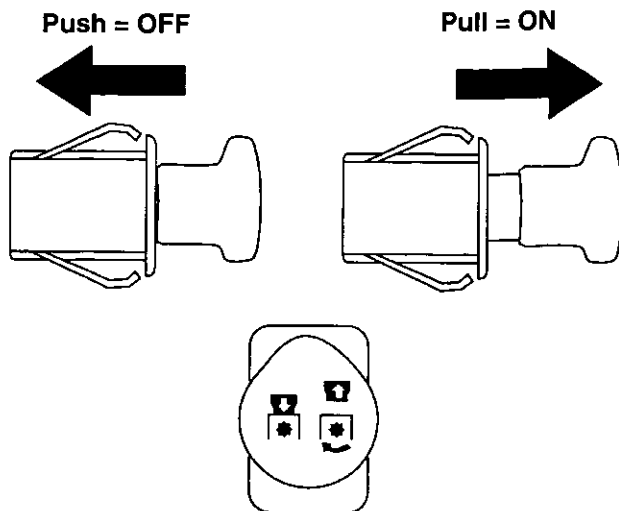

FIGURE 16.

**NOTE:** The PTO switch **must** be in OFF position when starting the engine, when shifting into reverse and if the operator leaves the seat.

### INDICATOR LIGHTS

The unit is equipped with three indicator lights, located on the dash panel. See figure 16. If a light illuminates when attempting to start the unit, proceed as follows:

CLUTCH—Depress the clutch pedal.

PTO—Disengage the PTO.

OIL—Check the crankcase oil level, and add oil as required.

### CUTTING CONTROLS

#### A. LIFT LEVER

The lift lever is used to raise and lower the cutting deck or other attachments.

#### B. DECK HEIGHT ADJUSTMENT INDICATOR

The deck height adjustment indicator is used to mark the cutting height. To select a cutting height, place the lift lever in the highest position. Dial the height you desire; pull the lift lever out of the notch in the index bracket and lower the handle to the desired position. Place the lift lever into the closest notch in the index bracket.

Turn the deck height adjustment indicator clockwise for a higher cutting height; turn it counterclockwise for a lower cutting height.

**IMPORTANT:** Do not attempt to change the deck height adjustment indicator when the lift handle is locked in a notch on the index bracket.

### C. DECK WHEELS OR ROLLER

After setting the cutting height, move deck wheels or roller to the hole location so they are 1/4 to 1/2 inch above the ground.

**NOTE:** When using the optional snow thrower attachment, the deck height adjustment indicator should be turned all the way to low position so the snow thrower will reach the ground. Or if blowing snow off gravel, turn the deck height adjustment indicator to a slightly higher position to avoid scraping the gravel.

## OPERATION



### WARNING

#### AVOID SERIOUS INJURY OR DEATH

- GO UP AND DOWN SLOPES, NOT ACROSS. • AVOID SUDDEN TURNS.
- DO NOT OPERATE THE UNIT WHERE IT COULD SLIP OR TIP.
- IF MACHINE STOPS GOING UPHILL, STOP BLADE(S) AND BACK DOWNHILL SLOWLY.
- DO NOT MOW WHEN CHILDREN OR OTHERS ARE AROUND.
- NEVER CARRY CHILDREN.
- LOOK DOWN AND BEHIND BEFORE AND WHILE BACKING.
- KEEP SAFETY DEVICES (GUARDS, SHIELDS, AND SWITCHES) IN PLACE AND WORKING.
- REMOVE OBJECTS THAT COULD BE THROWN BY THE BLADE(S).
- KNOW LOCATION AND FUNCTION OF ALL CONTROLS.
- BE SURE BLADE(S) AND ENGINE ARE STOPPED BEFORE PLACING HANDS OR FEET NEAR BLADE(S).
- BEFORE LEAVING OPERATOR'S POSITION, DISENGAGE BLADE(S), PLACE THE SHIFT LEVER IN NEUTRAL, ENGAGE BRAKE LOCK, SHUT ENGINE OFF AND REMOVE KEY.

READ OPERATOR'S MANUAL

### GAS AND OIL FILL-UP

Check oil level and add if necessary. Service the engine with gasoline as instructed in the separate engine manual packed with your tractor. Read instructions carefully.

**IMPORTANT:** Your tractor is shipped with oil; however, you must check the oil level before operating. Be careful not to overfill.

The gasoline tank is located under the seat. The filler neck is behind the seat. Do not overfill.



**WARNING:** Never fill fuel tank indoors, with engine running or while engine is hot.

### OPERATING THE TRACTOR

**IMPORTANT:** This unit is equipped with a safety interlock system for your protection. The purpose of the safety interlock system is to prevent the engine from cranking or starting unless the clutch-brake pedal is depressed and the PTO switch is in the OFF position. In addition, the PTO switch must be in the OFF position when the unit is put into reverse or the engine will shut off. If the operator leaves the seat with the PTO ON and/or without setting the parking brake, the engine will shut off.



**WARNING:** Do not operate the tractor if the interlock system is malfunctioning because it is a safety device, designed for protection.

1. Place the PTO switch in the OFF position.
2. Depress the clutch-brake pedal and set the parking brake.
3. Place the hydrostatic control lever in the NEUTRAL (N) position.
4. Set the throttle control in the FAST position.
5. Pull out the choke control. (A warm engine requires less choking.)
6. Turn the ignition key to the right to the START position. After the engine starts, release the key. It will return to the ON position.
7. Slowly push in the choke as the engine warms up.
8. Depress the clutch-brake pedal so the parking brake is released and then release the clutch-brake pedal.
9. Move the hydrostatic control lever forward. The farther forward you move the hydrostatic control lever, the faster you will travel.
10. To stop the tractor, pull the hydrostatic control lever into NEUTRAL (N) or depress the clutch-brake pedal.
11. To shut off the engine, turn the ignition key to the left to the OFF position. Remove the key to prevent accidental starting while equipment is unattended.

Be sure that the lawn is clear of stones, sticks, wire, or other objects which could damage lawn tractor or engine. For best results and to insure more even grass distribution, do not mow when lawn is excessively wet.



**WARNING:** Before leaving the operator's position for any reason, disengage the blades, place the shift lever in neutral, engage the parking brake, shut engine off and remove the key.

When stopping the unit to empty a grass bag, etc., follow the instructions above. This procedure will also eliminate "browning" the grass, which is caused by hot exhaust gases from a running engine.

**IMPORTANT:** If you strike a foreign object, stop the engine. Remove wire from spark plug, thoroughly inspect the mower for any damage, and repair the damage before restarting and operating the mower.

**NOTE:** If any problems are encountered, refer to the Trouble Shooting Guide.

GRASS COLLECTOR Model 190-083 is available as optional equipment for the lawn tractors with 46" decks shown in this manual.



**WARNING:** The mower should not be operated without the entire grass catcher or chute deflector in place.

**NOTE:** Under normal usage bag material is subject to wear, and should be checked periodically. Be sure to use only factory authorized replacement bag.

## ADJUSTMENTS



**WARNING:** Disconnect the spark plug wires and ground against the engine before performing any adjustments, repairs or maintenance.

### SEAT ADJUSTMENT

To adjust the position of the seat, loosen the four screws on the bottom of the seat. See figure 2. Slide the seat forward or backward as desired. Retighten the four screws.

### HYDROSTATIC NEUTRAL CONTROL ADJUSTMENT

The hydrostatic transmission control is in correct adjustment when the tractor does not move with the engine running, the clutch engaged and the hydrostatic control lever in the neutral position.

If adjustment is necessary, follow these steps:

1. Raise both rear wheels off the ground by placing blocks under the rear frame.
2. Remove the transmission panel by removing the parking brake knob and truss machine screws.
3. Loosen the hex jam nut on the speed selector adjusting rod. See figure 17.

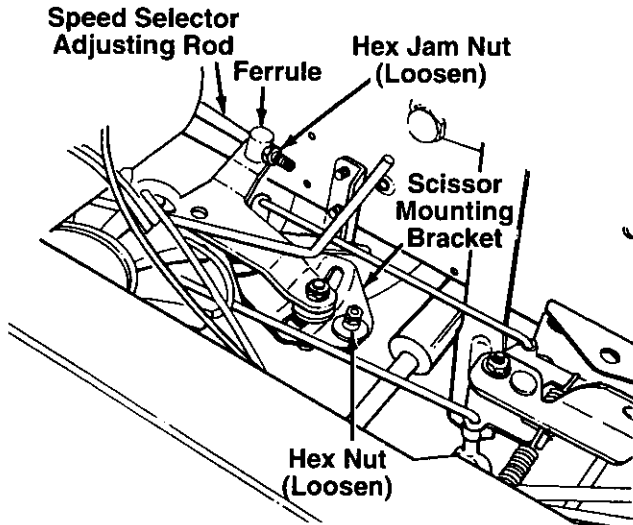

**FIGURE 17.**

4. Loosen the hex nut on the scissor mounting bracket. See figure 18.
5. Start the engine and run at full throttle.
6. Move the hydrostatic control lever until you find neutral (rear wheels do not rotate in either direction).



**WARNING:** Be careful of the cooling fan on the hydrostatic transmission.

7. Depress the clutch-brake pedal all the way and set the parking brake.
8. Shut off the engine.
9. Tighten the hex nut on the scissor mounting bracket.
10. Thread the speed selector rod in or out of the ferrule until the hydrostatic control lever lines up in the neutral position on the speed control index bracket.
11. Tighten hex jam nut against the ferrule.
12. Replace the transmission panel and parking brake knob.
13. Remove the blocks from under the frame and test the operation of the tractor.

### DECK LEVELING ADJUSTMENT

To correct for uneven cut, see deck leveling in the Assembly section.

### STEERING SHAFT ADJUSTMENT

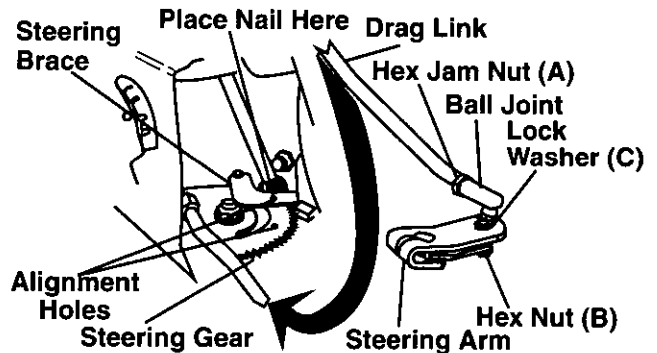

**FIGURE 18.**

If the tractor turns tighter in one direction compared to the other, the steering drag link must be adjusted. To adjust the drag link follow these steps. Refer to figure 18.

1. Loosen hex jam nut (A) at the rear of the ball joint.
2. Loosen and remove hex nut (B).
3. Lift the threaded portion of the ball joint out of the steering arm. Please do not misplace the hardware used to hold ball joint to steering arm. You will need it again.
4. Set the front wheels facing straight ahead.
5. Turn the steering wheel to the right or the left to match the alignment holes in the steering brace and the steering gear.
6. Once aligned, drop a nail through the steering brace and steering gear alignment holes.
7. Adjust the ball joint in or out on the drag link until the threaded portion of the ball joint slips through the hole in the steering arm. Make sure lock washer (C) is in position between the ball joint and the steering arm.
8. Tighten hex jam nut (A) against the ball joint.
9. Reattach the ball joint to the steering arm with hex nut (B). Finger tighten only at this time.

10. Turn the steering wheel fully to the left and the right to make sure that the drag link does not touch any part of the tractor frame. If the drag link does touch, start at step 1 and redo the adjustment.
11. Tighten hex nut (B).
12. Remove the nail used to align the steering gear.

### BRAKE ADJUSTMENT (See figure 19)

The brake is located by the right rear wheel inside the frame. During normal operation of this machine, the brakes are subject to wear and will require periodic examination and adjustment.



**WARNING: Do not adjust the brake while the engine is running. Be sure to block the wheels of the tractor before making the brake adjustment.**

To adjust the brake, remove the cotter pin. Adjust the castle nut so the brake starts to engage when the brake lever is 1/4" to 5/16" away from the axle housing.

**NOTE:** Figure 19 is shown with the unit tipped up on rear wheels for clarity only.

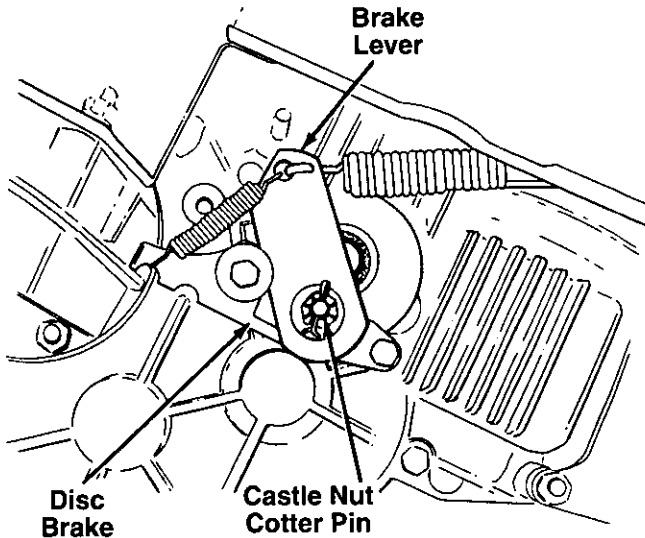

FIGURE 19.

### CARBURETOR ADJUSTMENTS



**WARNING:** If any adjustments are made to the engine while the engine is running (e.g. carburetor), disengage all clutches and blades. Keep clear of all moving parts. Be careful of heated surfaces and muffler.

Minor carburetor adjustments may be required to compensate for differences in fuel, temperature, altitude and load. Refer to separate engine manual for carburetor adjustment information.

**NOTE:** A dirty air cleaner will cause an engine to run rough. Be certain air cleaner is clean and attached to the carburetor before adjusting carburetor.

## LUBRICATION



**WARNING:** Always stop engine and disconnect spark plug wires before cleaning, lubricating or doing any kind of work on lawn tractor.

### STEERING GEARS

Lubricate teeth of steering gears with automotive multi-purpose grease after every 25 hours of operation or once a season. Refer to figure 18.

### STEERING SHAFT

Lubricate steering shaft at least once a season with light oil.

### HYDROSTATIC TRANSMISSION

The hydrostatic transmission is filled with approximately 60 ounces of API classification SH/CD 20W50 motor oil. Change the hydrostatic fluid and filter initially after 10 to 20 hours of operation, and every 200 hours of operation or once a year thereafter. Refer to Maintenance section.

### LINKAGE

Once a season lubricate all the pivot points on the clutch, brake and lift linkage with SAE 30 engine oil.

### FRONT WHEELS

The front wheels are provided with grease fittings. The rear wheels must be removed from the axle for lubrication. Lubricate at least once a season with automotive multi-purpose grease.

### PIVOT POINTS

Lubricate all pivot points with light oil at least once a season.

### BALL JOINTS

The ball joints and drag link ends are permanently lubricated.

## MAINTENANCE



**WARNING:** Disconnect the spark plug wire and ground against the engine before performing any adjustments, repairs or maintenance.

### TROUBLE SHOOTING

Refer to the chart on page 22 for trouble shooting engine problems.

### HYDROSTATIC TRANSMISSION

The hydrostatic transmission is cooled by the oil, fan and fins. If the hydrostatic transmission runs hot, check to see if the fan is in operating condition and the fins are clean.

**NOTE:** DO NOT use high pressure water spray or steam to clean the hydrostatic transmission.



## Hydrostatic Transmission Fluid and Filter

The hydrostatic transmission contains approximately 60 ounces of API classification SH/CD 20W50 motor oil. For operation in colder climates, 10W40 oil may be used. Also, a 15W50 synthetic engine oil would provide excellent all climate performance and extended time between oil changes. Use only filter part number HG-50037.

Change the hydrostatic transmission fluid and filter initially after 10 to 20 hours of operation, and every 200 hours of operation or once a year thereafter.

To change the hydrostatic transmission fluid and filter:

1. Remove oil filter on left side of transaxle and drain oil.
2. Clean around filter base and install new oil filter. Order part number HG-50037.
3. Raise rear of tractor and remove right rear wheel by removing hub cap, cotter pin and flat washer.
4. Level tractor by blocking rear axle.
5. Using a 1/4" allen wrench, remove the oil level plug from right side of transaxle. See figure 20.

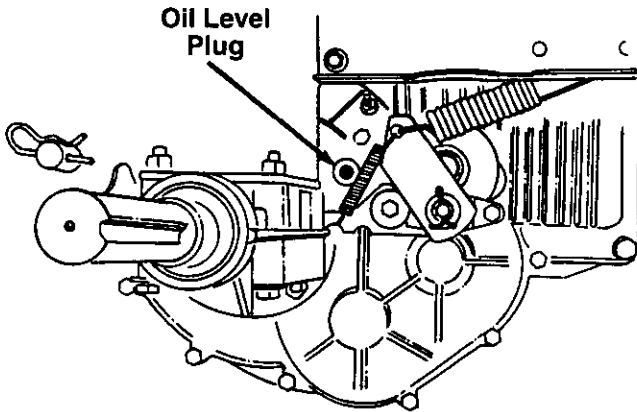

FIGURE 20.

6. Remove the transmission panel by removing the parking brake knob and truss machine screws.
7. Clean around filler hose (inside right frame) and bend hose upward. See figure 21.
8. Remove plastic vent from top of filler hose and insert a funnel. Fill transaxle with oil to the point of overflowing out of oil level hole.
9. Replace oil level plug and plastic vent.
10. Start tractor and run for 1 minute. Recheck oil level. Add oil if necessary.
11. Reassemble in reverse order.
12. Remove the blocks from under rear axle and test the operation of the tractor.

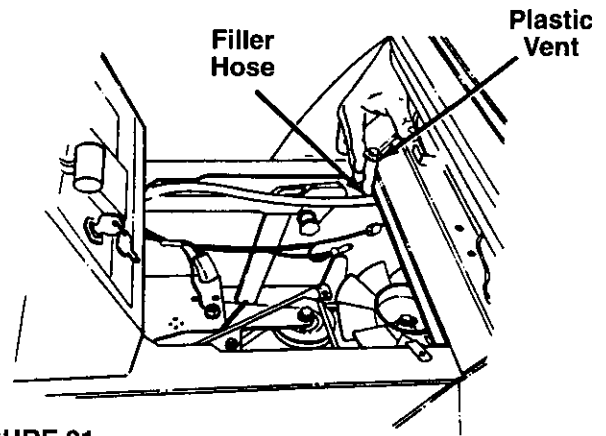

FIGURE 21.

## CUTTING BLADES



**WARNING: Protect hands by using heavy gloves or a rag to grasp the cutting blades.**

The blades may be removed for sharpening or replacement as follows:

### 50" Decks only:

1. Remove the bolt and washer which holds the blade and adapter to the blade spindle. Remove the blade and adapter from the blade spindle.
2. Remove the two bolts, lock washers and nuts holding the blade to the adapter. See figure 22A.

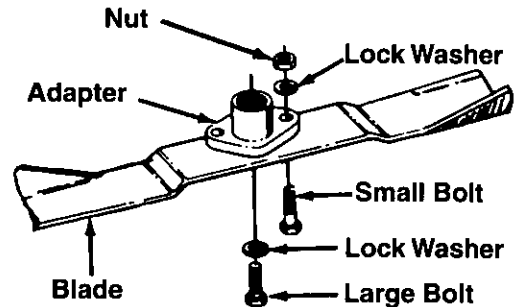

FIGURE 22A.—50" Deck

### 46" Decks Only:

1. Remove the hex flange nut that holds the blade to the spindle.

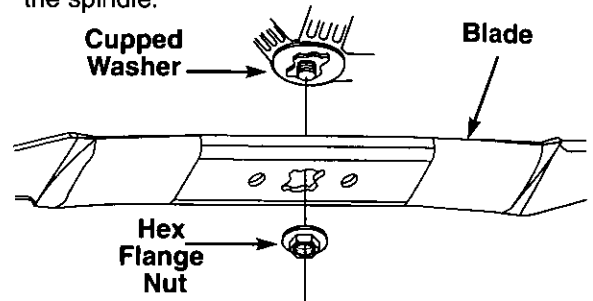

FIGURE 22B.—46" Deck

When sharpening the blades, follow the original angle of grind as a guide. It is **extremely important** that each cutting edge be ground equally to prevent an unbalanced blade. An unbalanced blade will cause excessive vibration when rotating at high speeds, may cause damage to the mower and could break, causing personal injury.

The blade can be tested for balance by balancing it on a round shaft screwdriver. Remove metal from the heavy side until it balances evenly.

When replacing the blade, be sure to install the blade with the side of the blade marked "Bottom" (or with part number) facing the ground when the mower is in the operating position.

### TORQUE SPECIFICATIONS

#### 46" Deck:

##### Blade

Hex Flange Nut: 70 ft.-lbs., 90 ft.-lbs.

##### Blade Spindle Screws

If disassembled for any reason, tighten the blade spindle screws between 200 and 275 inch pounds.

#### 50" Deck:

##### Blade

3/8" Dia. Bolt: 450 in. lb. min., 600 in. lb. max.

5/16" Dia. Bolt: 200 in. lb. min., 350 in. lb. max.

##### Blade Spindle Nuts

If disassembled for any reason, tighten the blade spindle nuts between 200 and 350 in. lbs.

To ensure safe operation of your unit, **all** nuts and bolts must be checked periodically for correct tightness.

## ENGINE

**Refer to the separate engine manual for all engine maintenance instructions.**

Service **air cleaner** every 10 hours under normal conditions. Clean every few hours under extremely dusty conditions. To service the air cleaner, refer to the separate engine manual packed with your unit.

The **spark plugs** should be cleaned and the gap reset once a season. Spark plug replacement is recommended at the start of each mowing season; check engine manual for correct plug type and gap specifications.

Maintain **engine oil** as instructed in the separate engine manual packed with your unit. **Read and follow instructions carefully.**

## FUEL FILTER

Your unit is equipped with a replaceable in-line fuel filter. Replace filter whenever contamination or discoloration is noticed. Order replacement filter through your authorized engine service dealer.

## CLEANING ENGINE AND DECK

Any fuel or oil spilled on the tractor should be wiped off promptly. Grass, leaves and other dirt must not be left to accumulate around the cooling fins of the engine or on any part of the machine.

Clean the underside of the deck after each mowing.

## WHEEL ADJUSTMENT

The caster (forward slant of the king pin) and the camber (tilt of the wheels out at the top) require no adjustment. Automotive steering principles have been used to determine the caster and camber on the tractor. The front wheels should toe-in 1/8 inch.

To adjust the toe-in, follow these steps.

1. Remove the hex nut and lock washer, and drop the end of the tie rod from the axle bracket. See figure 23.
2. Loosen the hex jam nut on tie rod.
3. Adjust the tie rod assembly for correct toe-in.

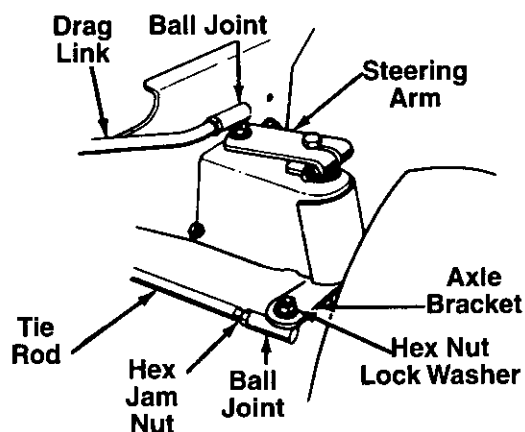

FIGURE 23.

Dimension "B" should be approximately 1/8" less than Dimension "A." See figure 24. To increase Dimension "B," screw tie rod into tie rod end. To decrease Dimension "B," unscrew tie rod from tie rod end. Reassemble tie rod. Check dimensions. Readjust if necessary.

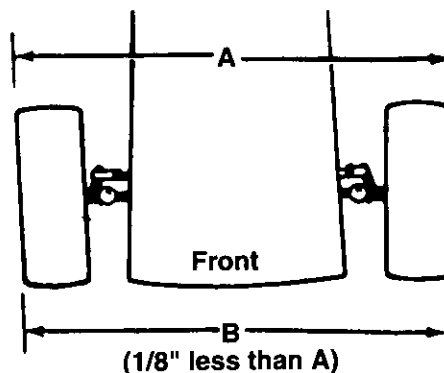

FIGURE 24.

## DRAG LINK

If the drag link or ball joints are changed, the new assembly must be adjusted to the exact same length as the original. If adjusted incorrectly, it will allow the tractor to turn sharper one direction than the other.

To take off the drag link, remove the nuts and lock washers holding the ball joint to the steering gear and right front axle bracket. See figure 23.

## BATTERY CARE AND MAINTENANCE

### CHECK FLUID LEVEL

Check fluid level inside each cell of the battery every two weeks and before and after charging. Always keep level just below the split rings.

**Add only distilled water. Never add additional acid** or any other chemicals to the battery after initial activation.

**NOTE:** After operating the lawn tractor for a long period of time, check the fluid level in the battery as it can overheat and lose fluid.

### CHARGING THE BATTERY

The engine is equipped with an alternator which charges battery when tractor is operated. Under normal conditions, the battery only needs to be charged before, during and after off-season storage. Follow the instructions under "Off-Season Storage."

**To charge the battery:** Make certain fluid level in each cell is just below the split rings. Use a 12 volt automotive charger which is rated at 6 amps. Charge for a minimum of 3 hours and a maximum of 5 hours.

## REMOVE / INSTALLING / JUMP STARTING



**WARNING:** When removing or installing the battery, follow these instructions to prevent the screwdriver from shorting against the frame.

**Removing the Battery:** Disconnect negative cable first, then positive cable.

**Installing the Battery:** Connect positive cable first, then negative cable.

### Jump Starting

1. First, connect end of one jumper cable to the positive terminal of the good battery, then the other end to the positive terminal of the dead battery.
2. Connect the other jumper cable to the negative terminal of the good battery, then to the **FRAME OF THE UNIT WITH THE DEAD BATTERY.**



**WARNING:** Failure to use this procedure could cause sparking, and the gas in either battery could explode.

## CLEAN THE BATTERY

Clean the battery by removing it from the unit and washing with a baking soda and water solution. If necessary, scrape the battery terminals with a wire brush to remove deposits. Coat terminals and exposed wiring with grease or petroleum jelly to prevent corrosion.

## BATTERY FAILURES

Some common causes for battery failure are: incorrect initial activation, lack of water, adding chemicals other than water after initial activation, undercharging, overcharging, corroded connections, freezing. These failures do not constitute warranty.

## TIRES

Recommended operating tire pressure is approximately 12 p.s.i. Maximum tire pressure under any circumstances is 30 p.s.i. Equal tire pressure should be maintained on all tires.

When installing a tire to the rim, be certain rim is clean and free of rust. Lubricate both the tire and rim generously. Never inflate to over 30 p.s.i. to seat beads.



**WARNING:** Excessive pressure (over 30 p.s.i.) when seating beads may cause tire/rim assembly to burst with force sufficient to cause serious injury.

## BELT REPLACEMENT

### DECK BELTS (See figure 25)

1. Remove the deck from the tractor by following "Attaching the Deck" instructions in the Assembly section in reverse order. Refer to page 8.
2. Remove the left hand pulley cover by unhooking the spring and removing five self-tapping screws.
3. Remove the first drive belt.
4. Remove the right hand pulley cover by removing three self-tapping screws.
5. Pivot the spring-loaded idler, and lift belt off.
6. Remove the belt from around the three deck pulleys.
7. Reassemble new belts in reverse order.

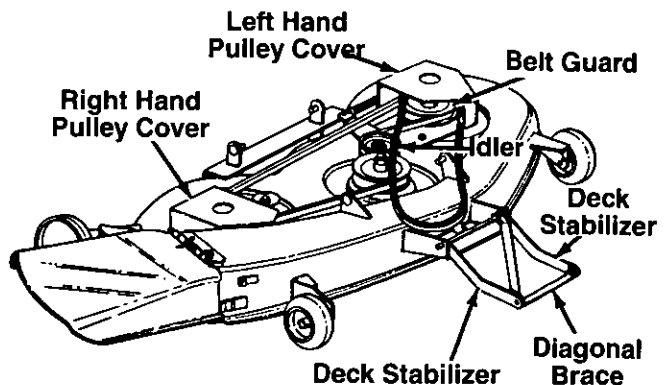

FIGURE 25.—46" Deck Shown

## DRIVE BELT (See figure 26)

1. Depress the clutch pedal and set parking brake.
2. Remove the deck from the tractor by following "Attaching the Deck" instructions in the Assembly section in reverse order.
3. Raise and block the front wheels of the tractor so you can work under it.
4. Remove the four self-tapping screws which hold the belt keeper assembly to the frame at the engine pulley. Push the belt keeper assembly forward, out of the way. See figure 26.
5. Loosen the hex bolt which acts as a belt keeper by the front idler pulley.
6. Loosen the rear idler pulley. Remove the belt from around both idler pulleys.
7. Unplug the electric PTO.
8. Roll belt up off engine pulley, onto the pulley hub to obtain slack in the belt.
9. Remove belt from the transmission pulley, lifting the belt up over the fan on top of the pulley.
10. Remove belt from the engine pulley.

Reassemble using a new belt, following instructions in reverse order.

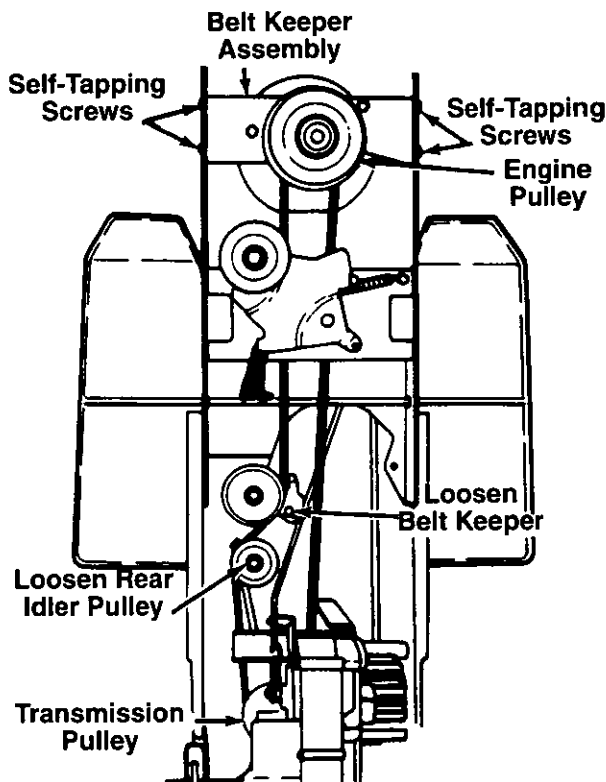

FIGURE 26.

## OFF-SEASON STORAGE

If the machine is to be inoperative for a period longer than 30 days, prepare for storage as follows.

1. Clean the engine and the entire unit thoroughly.
2. Lubricate all lubrication points. Wipe the entire machine with an oiled rag to protect the surfaces.
3. Refer to the engine manual for correct engine storage instructions. The engine must be completely drained of fuel to prevent gum deposits from forming on essential carburetor parts, fuel lines and fuel tanks.
4. **Charge battery fully.** The battery loses some of its charge each day when the unit is not used. NEVER store battery without a full charge. Recharge battery before returning to service or every two months, whichever occurs first.
5. When storing unit for extended periods, disconnect battery cables. Removing battery from unit is recommended.
6. Store unit in a clean, dry area. Do not store next to corrosive materials, such as fertilizer.

**NOTE:** When storing any type of power equipment in an unventilated or metal storage shed, care should be taken to rustproof the equipment. Using a light oil or silicone, coat the equipment, especially any chains, springs, bearings and cables.

# OPTIONAL EQUIPMENT

At the time of manufacture of tractor, the following optional equipment is available.

Description	Model No.
40" Single Stage Snow Thrower	OEM-190-832
45" Two Stage Snow Thrower	OEM-190-831
48" Dozer Blade	OEM-190-840
46" Deck Mulching Kit	OEM-190-118
Grass Collector for <u>46" Deck Only</u>	OEM-190-083
Tire Chains—23 x 9.5	OEM-190-964
100 lb. Wheel Weights	190-784-000
Sleeve Hitch Kit	OEM-190-929
Electric Lift Kit	OEM-190-749
Row Crop Cultivator	OEM-190-984
28" PTO Driven Rear Mounted Tiller	OEM-190-756
38" 8 HP Rear Mounted Tiller	OEM-190-766
Single Disc Harrow	OEM-190-980
10" Moldboard Plow	OEM-190-978
Gang Reel (Set of three)	45-0195*
38" Lawn Sweeper	45-0222*
Heavy Duty Lawn Roller	45-0179*
Heavy Duty Dump Cart	45-0171*
Tine De-Thatcher	45-0186*

\* Available through your local dealer or from Agri-Fab Inc., 303 W. Raymond Street, Sullivan, Illinois 61951.

# TROUBLE SHOOTING GUIDE

PROBLEM	POSSIBLE CAUSE(S)	CORRECTIVE ACTION
Engine will not crank	Safety switch button not depressed	There are two switches in the starting circuit of your unit: the clutch pedal switch and the deck lift lever switch. Make certain the actuator is fully depressing the buttons on each switch.
	Battery installed	The battery must be installed with negative terminal attached to black ground wire. Negative terminal is incorrectly identified at the post by "NEG", "N" or "-". The positive terminal, identified by "POS", "P" or "+", must be attached to the big red wire which goes to the solenoid.
	Battery is dead or weak	Check fluid level in battery. If fluid is low, fill to just below split rings with water. Charge with 6 amp charger until fully charged.
	Blown fuse or circuit breaker	Replace fuse with automotive type fuse. Fuses seldom fail without a reason. The problem must be corrected. Check for loose connections in the fuse holder. Replace fuse holder if necessary. A dead short may be in the cranking or charging circuit where the insulation may have rubbed through and exposed the bare wire. Replace the wire or repair with electrician's tape if the wire strands have not been damaged. Note: Look for a wire pinched between body panels, burned by the exhaust pipe or muffler or rubbed against a moving part.
	Engine ground wire loose	Engine should have a black ground wire running from engine to frame or mounting bolt.
Engine cranks but will not start	Throttle or choke not in starting position	Check owner's guide for correct position for throttle control and choke for starting.
	No spark to spark plug	Spark plug lead disconnected. Connect lead. Place spark plug lead away from engine block about 1/8". Crank engine. There should be a spark. If not, have engine repaired at authorized engine service dealer.  Faulty spark plug. To test, remove spark plug. Attach spark plug lead to spark plug. Ground the spark plug body against the engine block. Crank the engine. The spark plug should fire at the electrode. Replace if it does not.
	No fuel to the carburetor  Air filter dirty	Gasoline tank empty. Fill. Fuel line or in-line fuel filter plugged. Remove and clean fuel line. Replace filter if necessary.  If the air cleaner is dirty, the engine may not start. Clean or replace as recommended by the engine manufacturer.
Engine smokes	Engine loses crankcase vacuum	Dipstick not seated or broken. Replace defective part. Engine breather defective. Replace.
Excessive vibration	Bent or damaged blade spindle	<b>Stop engine immediately.</b> Check all pulleys, blade adapters, keys, nuts and bolts for tightness and damage. Tighten or replace any damaged parts.
	Bent blade	<b>Stop engine immediately.</b> Replace damaged blade. Only use original equipment blades.
Mower will not discharge grass or leaves uncut strips	Engine speed low Speed selection Blades short or dull	Throttle must be set at full throttle. Use lower ground speed. The slower your ground speed, the better the quality of cut. Sharpen or replace blades (uncut strip problem only).

If the above steps fail to correct the problem, take the unit to your local authorized service dealer for repair.

# GT-185 / GT-205

Models 147U836H190 / 147Z836P190

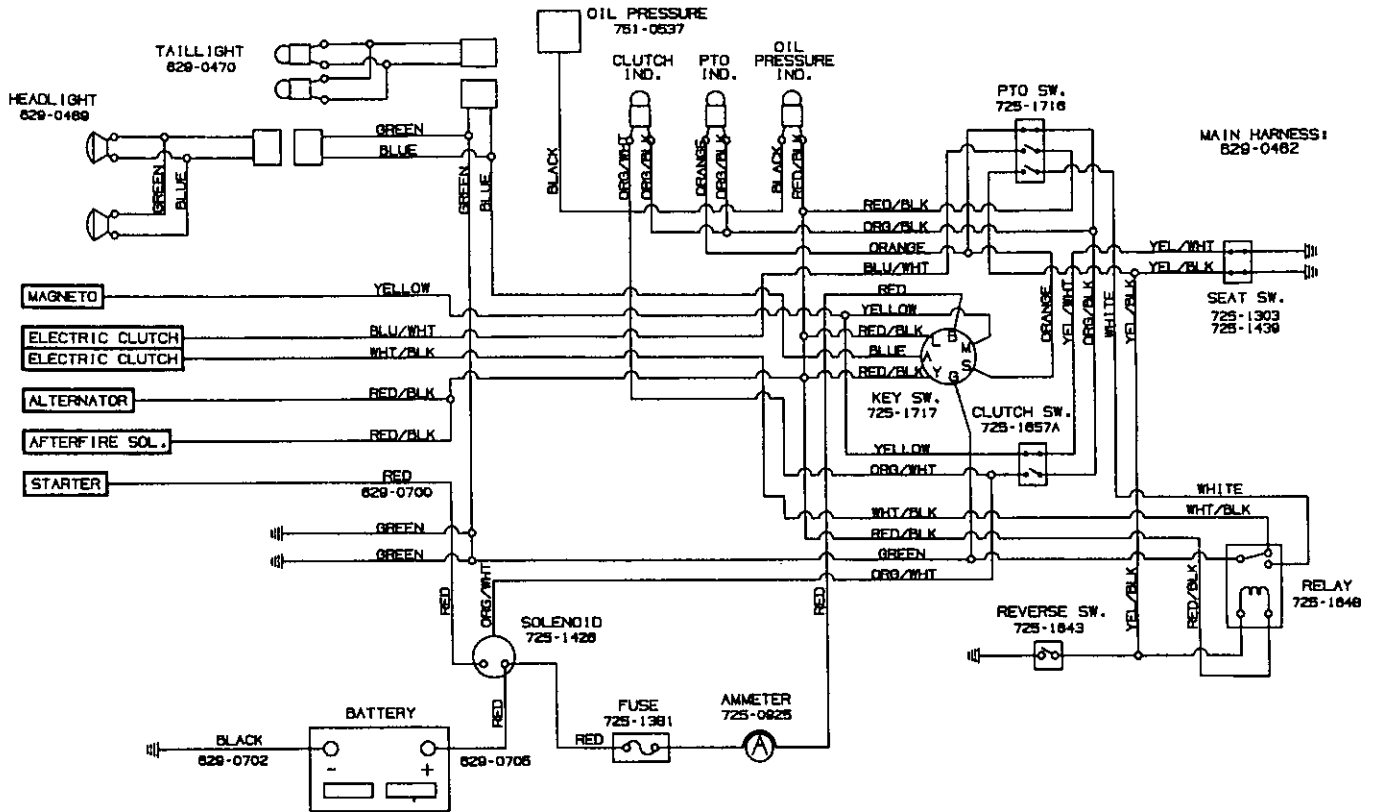

# GT-185 / GT-205

Models 147U836H190 / 147Z836P190

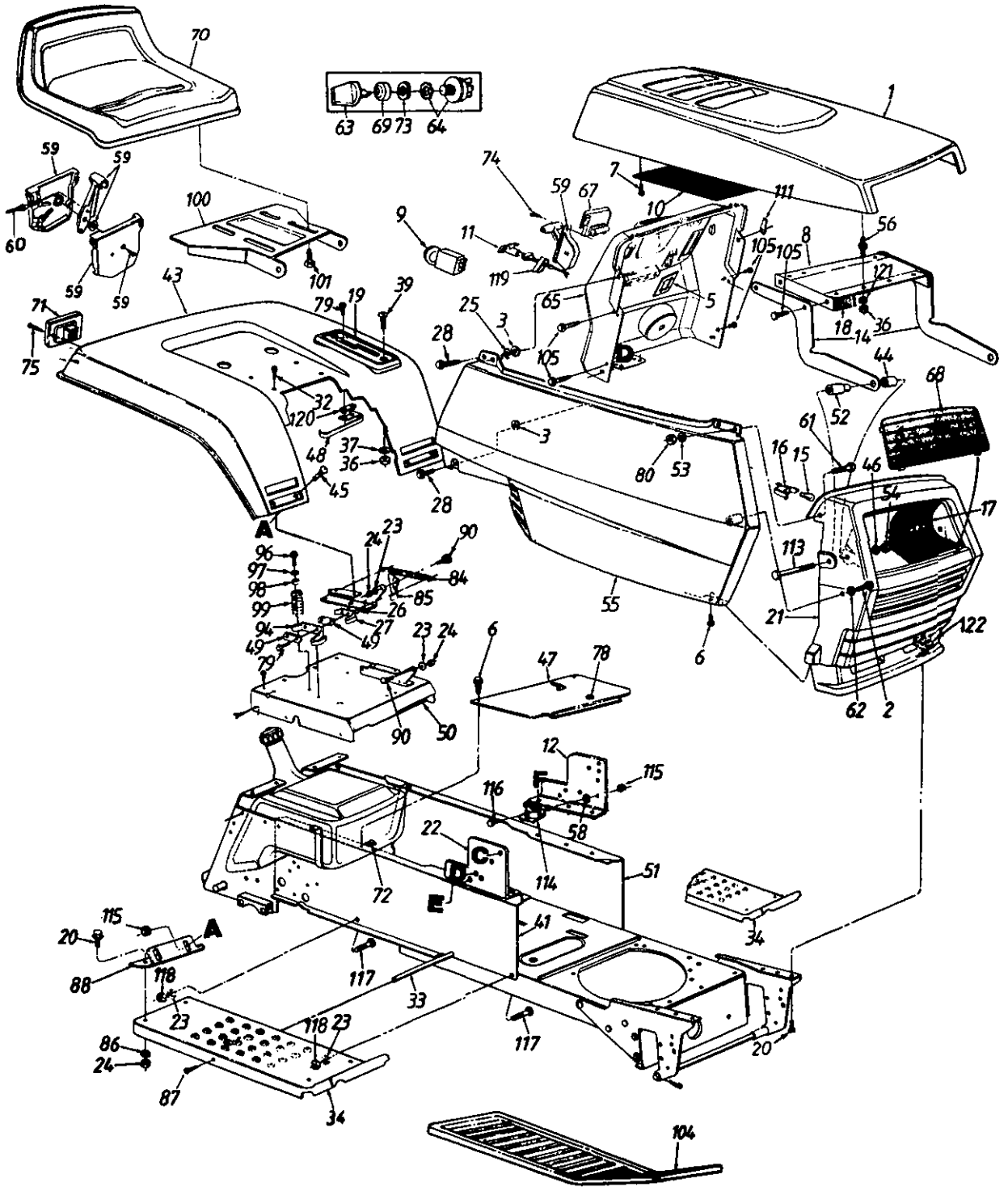



# GT-185 / GT-205

## Models 147U836H190 / 147Z836P190

### PARTS LIST FOR MODELS GT-185 AND GT-205 LAWN TRACTORS

REF. NO.	PART NO.	CODE	DESCRIPTION	REF. NO.	PART NO.	CODE	DESCRIPTION
1	731-1429		Hood	56	710-1034		Double Ended Stud 1/4-20 Thd.
2	710-0896		Hex Wash. B-Tap Scr. 1/4 x .62" Lg.	58	736-0222		Ext. L-Wash. 1/4" I.D.
3	726-0233		Bolt Retainer 1/4" I.D.	59	831-0823A		Throttle Control Box Ass'y.
5	783-0462	N	Switch Retainer	60	746-0630		Throttle Control Wire 39" Lg.
6	710-0351		Truss Mach. B-Tap Scr. #10 x .5" Lg.	61	710-0258		Hex Bolt 1/4-20 x .62" Lg.*
7	710-0227		Hex Wash. Hd. AB-Tap Scr #8 x .5" Lg.	62	736-0173		FI-Wash. .281" I.D. x .73" O.D.
8	16903A		Hood Plate	63	725-1341B		Ignition Key
9	725-1716	N	PTO Switch	64	725-1717	N	Ignition Switch
10	723-0416		Screen	65	731-1771	N	Dash Panel
11	746-0614A		Choke Control	67	725-0925		Ammeter
12	17294B		Dash Support Brkt.—L.H.	68	731-1038A	N	Lens
14	16902A		Hood Hinge	69	725-1347		Ignition Switch Cap
15	725-0963		Lamp	70	757-0370A	N	Seat Ass'y.
16	725-1649		Twist Lock—Lamp Socket	71	725-3018		Taillight Ass'y.
17	777-8516		Reflector—Headlight	72	726-0139		Speed Nut #10Z
18	722-0199		Foam Seal	73	725-1346		Ignition Switch Nut
19	731-1647		Speed Control Index Brkt.	74	710-0779A		Truss Mach. AB-Tap Scr. #10 x .5" Lg.
20	710-0118		Hex Bolt 5/16-18 x .75" Lg.*	75	710-0936		Truss Hd. AB-Tap Scr. #6 x .62"
21	731-1430B		Grille	78	731-0405		Snap Bushing
22	17293B		Dash Support Bracket—R.H.	79	710-0227		Hex Wash. Hd. AB-Tap Scr. #8 x .50" Lg.
23	736-0119		L-Wash. 5/16" I.D.*	80	712-0291		Hex L-Nut 1/4-20 Thd.
24	712-3010		Hex Sems Nut 5/16-18 Thd.	84	732-0581B		Ext. Spring 5.31" Lg.
25	736-0176		FI-Wash. 1/4" I.D. x .93" O.D.	85	17239A		Seat Lift Brkt.
26	726-0278		Insulator Boss Plate	86	736-0242		Bell-Wash. .345" I.D. x .88" O.D.
27	725-1439		Seat Spring Switch	87	710-0323		Truss Machine Scr. 5/16-18 x .75" Lg.
28	710-0642		Hex Wash. TT-Tap Scr. 1/4-20 x .75" Lg.	88	17406		Fender Bracket—R.H.
32	710-0726		Hex Wash. Hd. AB-Tap Scr. 5/16 x .75" Lg.		17407		Fender Bracket—L.H.
33	738-0435		Running Board Rod	90	738-0296		Shld. Bolt .437" Dia. x .268"
34	16922		Running Board—R.H.	94	725-1303		Spring Switch
	16921		Running Board—L.H.	96	710-0650		Hex Flange TT-Scr. 5/16-18 x .875"
36	712-0287		Hex Nut 1/4-20 Thd.*	97	736-0159		FI-Wash. 5/16" I.D.
37	736-0329		L-Wash. 1/4" I.D.*	98	722-0160		Bushing
39	710-0166		Truss Mach. Scr. 1/4-20 x 1.0" Lg.	99	732-0588		Compression Spring
41	17360C	N	R.H. Side Frame	100	783-0039A	N	Seat Pivot Bracket
43	17330A		Rear Fender	101	710-0870		Hex Tap Scr. 3/8-16 x .62" Lg.
44	750-0755		Spacer .33" I.D. x .625" O.D.	104	731-1052		Foot Pad
45	710-0167		Carriage Bolt 1/4-20 x .50" Lg.*	105	710-0599		Hex Tap Scr. 1/4-20 x .5" Lg.
46	736-0278		FI-Wash. .328" I.D. x .68" O.D.	111	712-0185		Speed Nut 1/4-20 Thd.
47	17393B	N	Transmission Panel	113	710-0176		Hex Bolt 5/16-18 x 2.75"
48	725-1643		Reverse Safety Switch	114	725-1426		Solenoid
49	726-0279		Insulator Plate	115	712-0271		Hex Sems Nut 1/4-20 Thd.
50	683-0108A	N	Seat Plate	116	710-0289		Hex Bolt 1/4-20 x .5" Lg.*
51	17361C		L.H. Side Frame	117	710-1012		Rib Neck Bolt 5/16-24 x .75" Lg.
52	750-0754		Shld. Spacer .33" I.D.	118	712-0123		Hex Nut 5/16-24 Thd.
53	736-0142		FI-Wash. .281" I.D. x .5" O.D.	119	17782		Retainer Clip
54	712-0158		Hex Cent. L-Nut 5/16-18 Thd.	120	726-0320		Insulator Nut Plate
55	731-1890	N	Side Cover Ass'y.—R.H.	121	736-0270		Bell-Wash. .265" I.D. x .75" O.D.
	731-1891	N	Side Cover Ass'y.—L.H. (Not Shown)	122	726-0211		U-Nut 5/16-18 Thd.

\* For faster service obtain standard nuts, bolts and washers locally.  
If these items cannot be obtained locally, order by part number and  
size as shown on parts list.

# GT-185 / GT-205

Models 147U836H190 / 147Z836P190

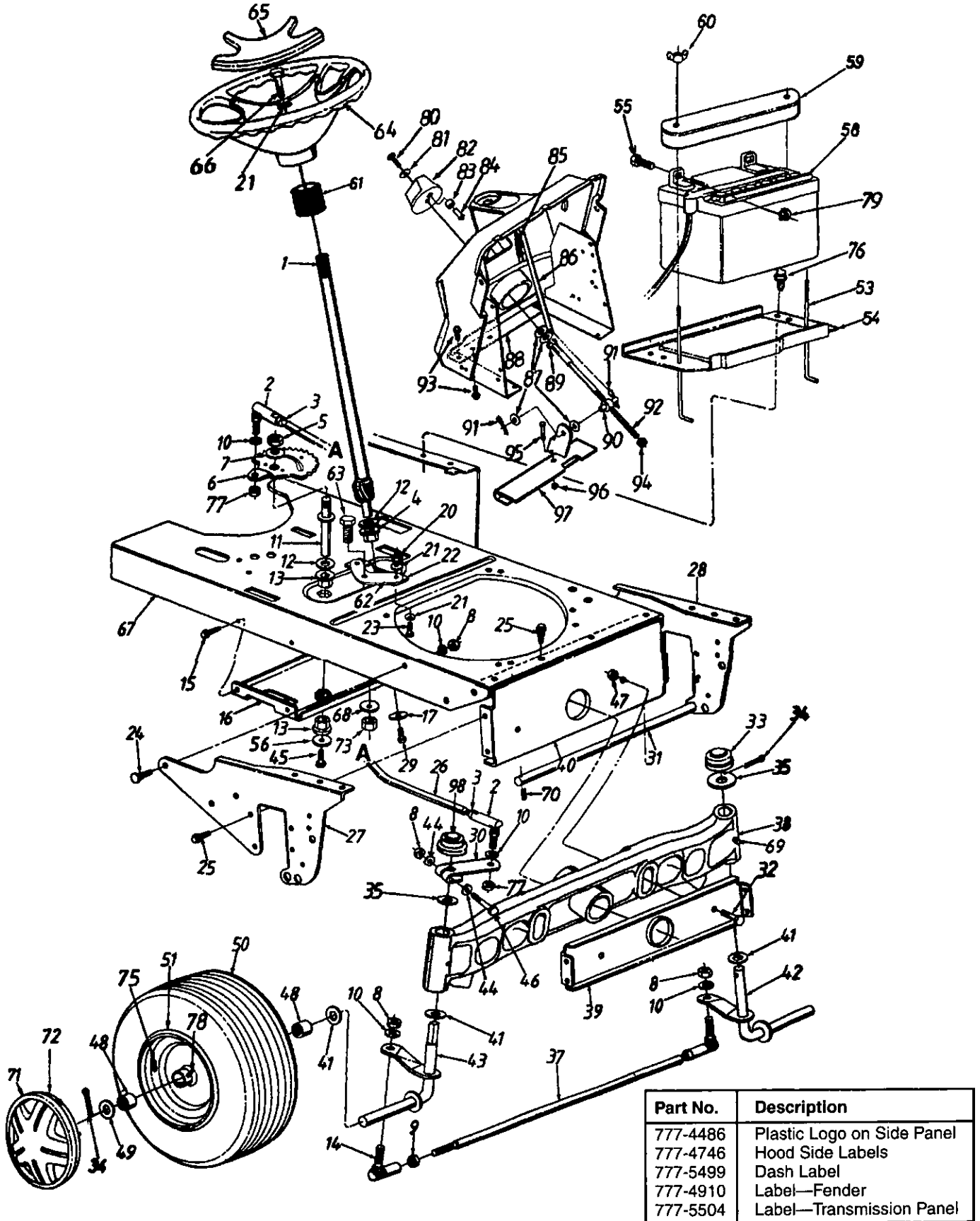

# GT-185 / GT-205

## Models 147U836H190 / 147Z836P190

### PARTS LIST FOR MODELS GT-185 AND GT-205 LAWN TRACTORS

REF. NO.	PART NO.	CODE	DESCRIPTION	REF. NO.	PART NO.	CODE	DESCRIPTION
1	738-0963	N	Steering Shaft Ass'y.	51	634-0071		Rim Only†
2	723-0448		Ball Joint 7/16-20 Thd.		634-0067		Rim Only††
3	712-0240		Hex Jam Nut 7/16-20 Thd.	53	711-0222A		Battery Hold Down Rod
4	741-0656		Hex Flange Brg.	54	783-0346A	N	Battery Plate
5	712-0318		Hex Jam Nut 5/8-18 Thd.*	55	710-3015		Hex Bolt 1/4-20 x .75" Lg. (Gr. 5)
6	717-0943C	N	Steering Gear Segment	56	736-0343		Fl-Wash. .33" I.D. x 1.25" O.D.
7	736-0317		Bell-Wash. 5/8" I.D. x 1.25" O.D.	58	725-1707B	N	Battery (275 Cold Crank Amps)
8	712-0241		Hex Nut 3/8-24 Thd.	59	731-1683		Battery Cover
9	712-0711		Hex Jam Nut 3/8-24 Thd.	60	712-3087		Wing Nut Plastic 1/4-20 Thd.
10	736-0169		L-Wash. 3/8" I.D.*	61	731-0954		Steering Bellow
11	738-0768		Steering Gear Segment Shaft	62	783-0465	N	Steering Brace
12	736-0187		Fl-Wash. .64" I.D. x 1.24" O.D.	63	738-0966	N	Shld. Bolt .5" Dia. x .925" Lg.
13	748-0227A		Hex Flange Brg. .63" I.D.	64	731-1686		Steering Wheel
14	723-3018		Ball Joint Ass'y.	65	731-1509A	N	Steering Wheel Insert
15	710-0599		Hex Wash. Hd. TT-Tap Scr. 1/4-20 x .5" Lg.	66	710-0643		Hex L-Bolt 5/16-18 x 1" Lg.
				67	17359C	N	Lower Frame
16	16888A		Deck Idler Support Brkt.	68	736-0452		Bell-Wash. .396" I.D. x 1.14" O.D.
17	748-0389		Cap 1.25" x .16"				
19	736-0119		L-Wash. 5/16" I.D.*	69	737-3000		Grease Fitting
20	712-0123		Hex Nut 5/16-24 Thd.*	70	714-0149B		Internal Cotter Pin
21	736-0242		Bell-Wash. .345" I.D. x .88" O.D.	71	734-1784A	N	Hub Cap
22	16894		Bearing Retainer Brkt.	72	727-0425A		Spring Clip
23	710-0157		Hex Bolt 5/16-24 x .75" Lg.	73	712-3017		Hex Nut 3/8-16 Thd.
24	710-0793		Ribbed Neck Bolt 3/8-24 x .8" Lg.	75	734-0255		Air Valve
25	710-0604		Hex Wash. TT-Tap Scr. 5/16-18 x .62" Lg.	76	710-0896		Hex Wash. B-Tap Scr. 1/4" x .62" Lg.
26	711-1106	N	Steering Drag Link	77	712-0262		Hex Jam L-Nut 3/8-24 Thd.
27	783-0338		Pivot Bar Side Plate—R.H.	78	737-0280		Grease Fitting
28	783-0337		Pivot Bar Side Plate—L.H.	79	712-0271		Hex Sems Nut 1/4-20 Thd.
29	710-1309		Pan Hd. Scr. 5/16-18 x .63" Lg.	80	710-3015		Hex Cap Bolt 1/4-20 x .75" Lg.
30	683-0061A		Steering Arm Ass'y.	81	736-0270		Bell-Wash. .265" I.D. x .75" O.D.
31	738-0777A		Deck Connecting Rod	82	720-0236		Plastic Knob 3" Dia.
32	738-0527		Shld. Bolt .498" Dia. x 2.45" Lg.	83	750-0526		Spacer .38" I.D. x .5" O.D.
33	731-0484A		Cap	84	732-0675		Ball Plunger
34	714-0121		Cotter Pin 5/32" Dia.	85	732-0748		Ext. Spring 4.62" Lg.
35	736-0316		Flat Washer	86	727-0469		Indicator Strip Ass'y.
37	747-0753		Tie Rod 20.25" Lg.	87	736-0267		Fl-Wash. 3/8" I.D. x .87" O.D.
38	719-0343		Pivot Bar Ass'y.	88	783-0272		Dash Support
39	16889A		Pivot Bar Support Brkt.—Front	89	716-0125		"E"-Ring
40	16890A		Pivot Bar Support Brkt.—Rear	90	711-1002		Adjustment Ferrule
41	736-0188		Fl-Wash. .76" I.D. x 1.49" O.D.	91	714-0101		Hairpin Clip
42	638-0007A	N	Front Axle Ass'y.—L.H.	92	747-0629		Height Adjustment Rod
43	638-0008A	N	Front Axle Ass'y.—R.H.	93	710-0604		Hex Wash. TT-Tap Scr. 5/16-18 x .62" Lg.
44	736-0286		Bowed Washer				
45	710-0538		Hex L-Scr. 5/16-18 x .62" Lg.	94	712-0449		Hex L-Nut 3/8-8 Twin Thd.
46	710-0331		Hex Bolt 3/8-24 x 2.25" Lg.	95	710-0606		Hex Bolt 1/4-20 x 1.5" Lg.
47	712-0431		Hex L-Nut 3/8-16 Thd.	96	712-0324		Hex L-Nut 1/4-20 Thd.
48	741-3032		Ball Brg. .75" I.D.	97	683-0096		"U" Channel Ass'y.
	741-0516		Flange Brg. .75" I.D.††	98	726-0341		Cap
49	736-0316		Fl-Wash. .71" I.D. x 1.5" O.D.				
50	734-1722		Wheel Ass'y. Comp.†				
	634-0084		Wheel Ass'y. Comp.††				
	734-0275		Tire Only†				
	734-1727		Tire Only††				

† Model 147U836H190 Only.  
 †† Model 147Z836P190 Only.

\* For faster service obtain standard nuts, bolts and washers locally.  
 If these items cannot be obtained locally, order by part number and size as shown on parts list.

# GT-185 / GT-205

Models 147U836H190 / 147Z836P190

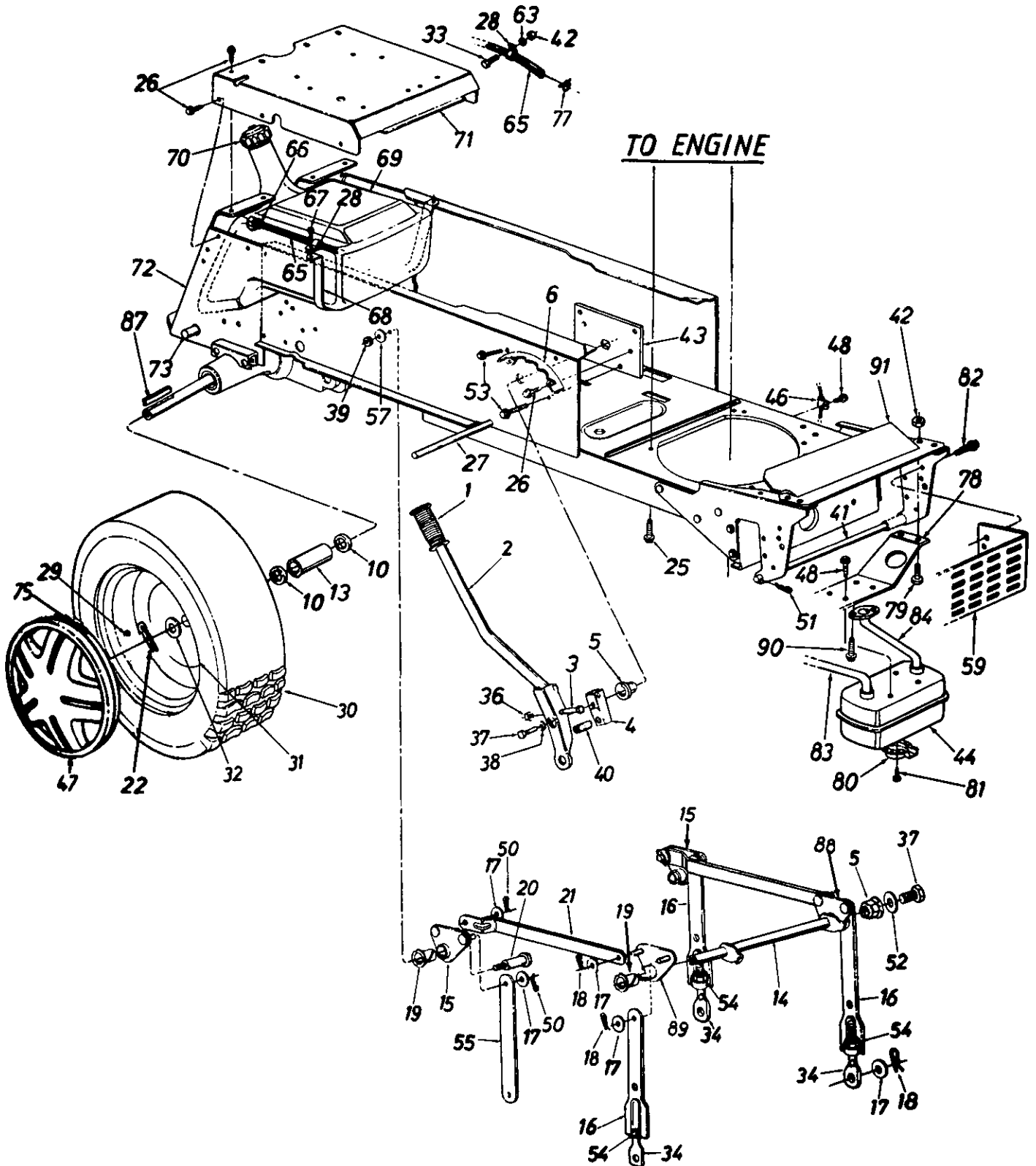

# GT-185 / GT-205

## Models 147U836H190 / 147Z836P190

### PARTS LIST FOR MODELS GT-185 AND GT-205 LAWN TRACTORS

REF. NO.	PART NO.	CODE	DESCRIPTION	REF. NO.	PART NO.	CODE	DESCRIPTION
1	720-0233		Grip	44	751-0616		Muffler
2	17282		Lift Handle Ass'y.	46	726-0273		Mounting Clamp
3	710-0442		Hex Bolt 5/16-18 x 1.5" Lg.*	47	734-1785A	N	Hub Cap
4	748-0274A		Lift Shaft Drive	48	710-0599		Hex Wash. Hd. TT-Tap Scr. 1/4-20 x .5" Lg.
5	741-0225		Plastic Hex Brg. 5/8" I.D.				Cotter Pin .09 Dia. x 1.0" Lg.
6	14231		Index Brkt. Deck Lift	50	714-0111		Int. Cotter Pin
7	737-0286		Oil Drain Pipe (Not Shown)	51	714-0149B		Flat Wash. .34" I.D. x 1.12" O.D. x .125"
8	751-0572		Oil Drain Plug (Not Shown)	52	736-0231		Hex Wash. Hd. AB-Tap Scr. 5/16-18 x .5" Lg.
10	736-0163		FI-Wash. 1.03" I.D. x 1.62" O.D.				Hex Nut 1/2-13 Thd.
13	750-0762		Spacer 1" I.D. x 1.25" O.D.	53	710-0607		Deck Link
14	983-0101		Lift Shaft Ass'y.				Bell-Wash. .4" I.D. x 1.13" O.D.
15	13895		Lift Pivot Brkt. Ass'y.	54	712-0206		Heat Shield
16	17303		Adj. Deck Lift Link	55	14399		L-Wash. 1/4" I.D.*
17	736-0192		FI-Wash. 1/2" I.D. x 1.00" O.D. x .090"	57	736-0219	N	Fuel Line 46" Lg.
18	714-0101		Hairpin Cotter	59	783-0023A		Hose Clamp
19	741-0591		Flanged Brg. 5/8" I.D.	63	736-0329		Hex AB-Tap Scr. 1/4 x .62" Lg.
20	738-0445		Shld. Bolt 5/8" Dia. x .96" Lg. 3/8-16	65	751-0535-46		Fuel Tank Strap
21	13790		Connecting Link	66	726-0205		Gas Tank
22	714-0142		Cotter Pin 3/16" Dia. x 1.5" Lg.	67	710-0776		Gas Gauge
25	710-0502A		Hex Wash. Hd. Scr. 3/8-16 x 1.25" Lg.	68	17424		Seat Plate
26	710-0726		Hex Thd. Rolling Scr. 5/16-18 x .75" Lg.	69	751-0566		Hitch Plate
27	738-0435		Running Board Rod	70	751-0531B		Hitch Rod
28	726-0272		Clamp	71	683-0108A		Spring Clip
29	734-0255		Air Valve	72	17344A		Hose Clamp
30	734-1005		Rear Wheel Ass'y. Comp.†	73	738-0482		Muffler Mounting Brkt.
	634-0086		Rear Wheel Ass'y. Comp.††	75	727-0425A		Hex Bolt 1/4-20 x .62" Lg.
	734-0322		Tire Only†	77	726-0272		Muffler Deflector
	734-1728		Tire Only††	78	17958		Hex Wash. Hd. F-Tap Scr. #8 x .32" Lg.
31	734-1015		Rear Wheel Rim Only	79	710-0258		Hex Wash. Hd. TT-Tap Scr. 5/16"-18 x .62" Lg.
32	736-0345		Flat Washer	80	751-0564		Exhaust Tube—R.H.
33	710-0258		Hex Bolt 1/4-20 x .62" Lg.	81	710-0148		Exhaust Tube—L.H.
34	711-0817		Eye Bolt Adj. Link 1/2-13 Thd.	82	710-0604		Sq. Key 1/4" x 3" Lg.
36	712-0158		Hex Cent. L-Nut 5/16-18 Thd.	83	751-0558	N	Lift Pivot Brkt.—L.H.
37	710-0157		Hex Bolt 5/16-24 x .75" Lg. (Gr. 5)*	84	751-0559A		Lift Pivot Brkt.—R.H.
39	712-0181		Hex Top L-Nut 3/8-16 Thd.	87	714-0120		Socket Scr. M8 x 1.25" x 20MM Lg.
40	732-0369		Compression Spring	88	683-0097		Heat Shield
41	738-0777		Deck Connecting Rod	89	683-0098		
42	712-0271		Hex Sems Nut 1/4-20 Thd.	90	710-3292		
43	14170		Index Brkt. Reinforcement Plate	91	783-0394	N	

† Model 147U836H190 Only.

†† Model 147Z836P190 Only.

\* For faster service obtain standard nuts, bolts and washers locally.  
If these items cannot be obtained locally, order by part number and  
size as shown on parts list.

# GT-185 / GT-205

Models 147U836H190 / 147Z836P190

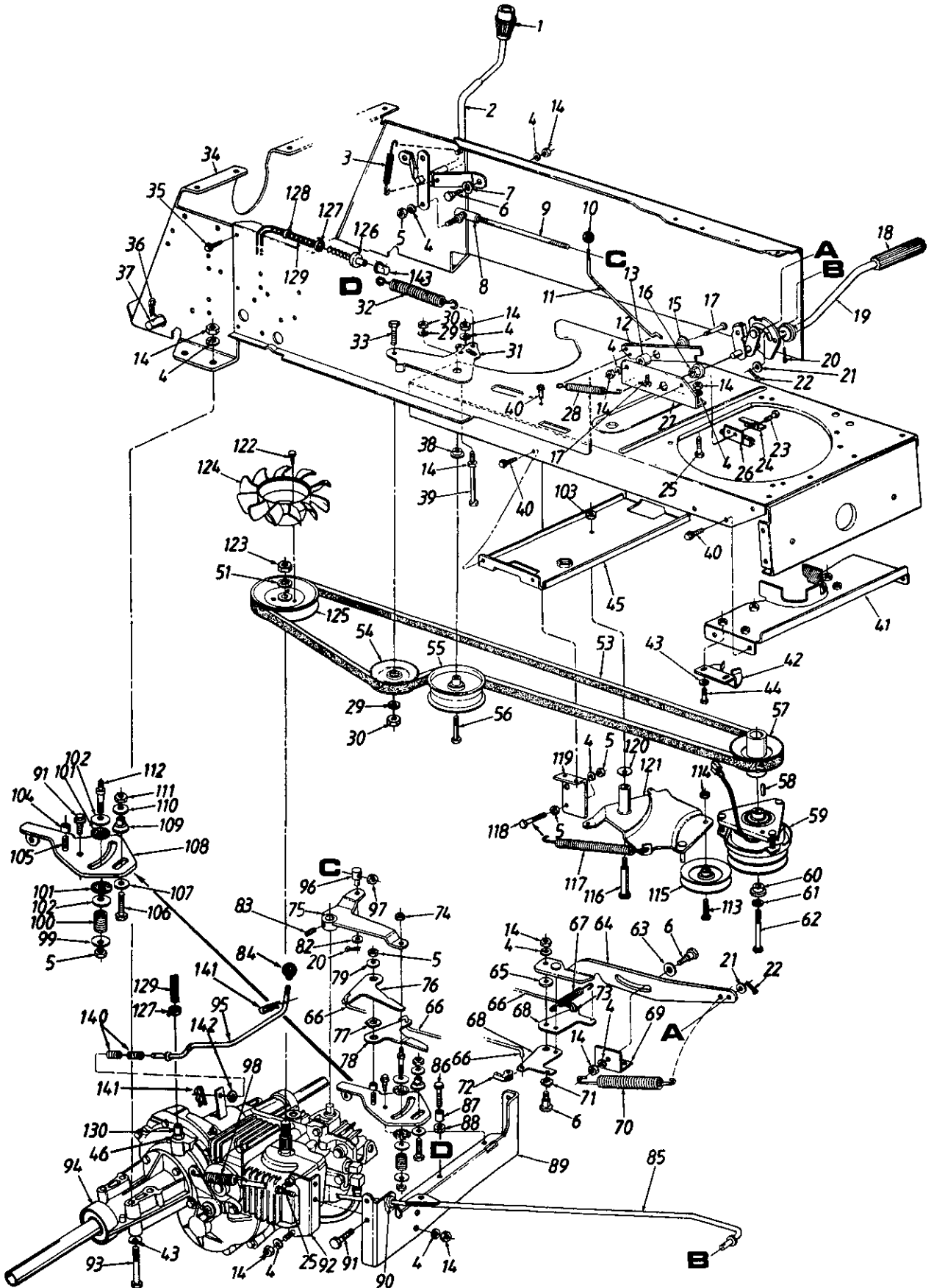

**PARTS LIST FOR MODELS GT-185 AND GT-205 LAWN TRACTORS**

REF. NO.	PART NO.	CODE	DESCRIPTION	REF. NO.	PART NO.	CODE	DESCRIPTION
1	720-0218	N	Shift Knob	65	736-3074		Fl-Wash. .344" I.D. x 1.12" O.D. (Hdn.)
2	647-0010		Speed Control Lever Ass'y.				Connecting Rod
3	732-0433		Ext. Spring 2.75" Lg.	66	747-0880		Ext. Spring 2.5" Lg.
4	736-0119		L-Wash. 5/16" I.D.*	67	732-0387		Balancer Brkt.
5	712-0123		Hex Nut 5/16-24 Thd.*	68	17757		Bracket
6	738-0296		Shld. Bolt .437" Dia. x .268"	69	17755A		Ext. Spring 3.94" Lg.
7	736-0141		Spr. Wash. .445" I.D. x .75" O.D.	70	732-0717		Spr.-Wash. .445" I.D. x .75" O.D.
8	723-3012		Ball Joint 5/16-24 Thd.	71	736-0141		Rod End Clevis Clip—R.H.
9	747-0857		Speed Selector Adjusting Rod	72	726-0281		Rod End Clevis Clip—L.H.
10	720-0166		Ball Knob	73	726-0280		Hex Ins. L-Nut 3/8-24 Thd.
11	747-0876		Brake Lockout Rod	74	712-0116		Pintle Bracket Ass'y.
12	16980A		Brake Lockout Brkt.	75	683-0032A		Flat Scissors
13	750-0214		Spacer .34" I.D. x .88" O.D.	76	783-0053		Spr. Wash. .625" I.D. x .885" O.D.
14	712-3010		Hex Nut 5/16-18 Thd. (Gr. 5)	77	736-0174		Offset Scissors
15	748-0234		Shld. Spacer .27" Lg.	78	783-0054		Fl-Wash. .344" I.D. x 1" O.D. (Hdn.)
16	741-0225		Hex Flange Bearing	79	736-3078		Fl-Wash. .406" I.D. x .75" O.D.
17	710-0528		Hex Bolt 5/16-18 x 1.25" Lg				Hex Socket Set Screw
18	735-0196		Foot Pad	82	736-0185		Ball Knob
19	17911		Foot Pedal Ass'y.	83	710-0257		Brake Rod Ass'y.
20	714-0111		Cotter Pin 3/32" Dia. x 1" Lg	84	720-0187		Hex Wash. Hd. Scr. 1/4-20 x 1.5" Lg.
21	736-0275		Fl-Wash. .34" I.D. x .68" O.D.	85	747-0859		Spacer .39" Lg.
22	714-0115		Cotter Pin 1/8" Dia. x 1" Lg.	86	710-0778		Hex Nut 1/4-20 Thd. (Gr. 5)
23	710-0436		Hex B-Tap Scr. #10 x .62" Lg.				Transaxle Torque Brkt.
24	17962		Switch Plate	87	750-0555		Grommet
25	710-0118		Hex Bolt 5/16-18 x .75" Lg.	88	712-3006		Hex Wash. Hd. TT-Tap Scr. 5/16-18 x .62" Lg.
26	725-1657A		Safety Switch (Clutch)	89	783-0051		Transaxle Torque Brace
27	16924A		Clutch Ass'y. Mtg. Brkt.	90	731-0555A		Hex Bolt 5/16-18 x 3" Lg.
28	732-0395		Ext. Spring 2.51" Lg.	91	710-0604		Transaxle (See Breakdown)
29	736-0169		L-Wash. 3/8" I.D.*				Bypass Rod
30	712-3017		Hex Nut 3/8-16 Thd. (Gr. 5)	92	783-0050		Ferrule 3/8-24 Thd.
31	783-0056		Idler Brkt.	93	710-0189		Hex Jam Nut 3/8-24 Thd.
32	732-0470		Ext. Spring 4.75" Lg.	94	718-0241A		Ext. Spring 4.01" Lg.
33	710-0344		Hex Bolt 3/8-16 x 1.5" Lg.	95	747-0909		Fl-Wash. .312" I.D. x .75" O.D.
34	17344A		Hitch Plate	96	711-0198		Comp. Spring 1.19" Lg.
35	710-0726		Hex Wash. AB-Tap Scr. 5/16 x .75" Lg.	97	712-0711		Friction Washer
			98	732-0716		Bell-Wash. .40" I.D. x 1.13" O.D.	
36	714-0147	Hitch Pin	99	736-3008		Hex Cent. L-Nut 3/8-16 Thd.	
37	738-0482	Hitch Rod	100	732-0718		Spacer	
38	738-0347	Shld. Spacer .625" I.D.	101	761-0196		Rib Neck Bolt 5/16-18 x .62" Lg.	
39	710-0176	Hex Bolt 5/16-18 x 2.75" Lg.	102	736-0219		Hex Bolt 1/4-28 x 1" Lg. (Gr. 5)	
40	710-0599	Hex Wash. Hd. TT-Tap Scr. 1/4-20 x .5" Lg.	103	712-0375		Fl-Wash. .26" I.D. x .72" O.D.	
			104	750-0808		Scissors Mtg. Brkt.	
41	17358D	Belt Guard Brkt.	105	710-1012		Centering Gauge Spacer	
42	17418	Torque Bracket	106	710-0299		Bell-Wash. 1/4" I.D.	
43	736-0242	Bell-Wash. .345" I.D. x .88" O.D.	107	736-3090		Hex Nut 1/4-28 Thd.*	
44	710-3008	Hex Cap Scr. 5/16-18 x .75" Lg. (Gr. 5)	108	783-0052		Friction Disc Stud	
			109	750-0918		Hex Bolt 3/8-24 x 1.5" Lg.	
45	16888	Deck Idler Support Brkt.	110	736-0270		Hex Cent. L-Nut 3/8-24 Thd.	
46	721-0330	O-Ring	111	712-0138		"V"-Belt Idler	
53	754-0435	"V"-Beit	112	738-0879		Shld. Bolt .498" Dia. x 2.05	
54	756-0116	Idler Pulley	113	710-0459		Ext. Spring 4" Lg.	
55	756-0515	Fl-Idler Pulley	114	712-0214		Hex Bolt 5/16-24 x 1.25" Lg.	
56	710-3096	Hex Bolt 3/8-16 x 2" Lg. (Gr. 8)	115	756-0293A		Parking Brake Mtg. Brkt.	
57	756-0637	Engine Pulley	116	738-0129		Bell-Wash. .38" I.D. x .88" O.D.	
58	714-0128	Sq.-Key 1/4" x 1" Lg.	117	732-0180		Idler Brkt. Deck Ass'y.	
59	717-1434	Electric Clutch	118	710-0158		Hex Wash. Hd. Tap Scr. #12 x 3/8" Lg.	
60	738-0785	Shld. Spacer	119	13833			
61	736-0171	L-Wash. 7/16" I.D.	120	736-0105			
62	710-1049	Hex Cap Bolt 7/16-20 x 3.75" Lg.	121	14076A			
63	736-0179	Fl-Wash. .531" I.D. x 1.25" O.D.	122	710-3007			
64	683-0030	Neutral Return Link Ass'y.					

# GT-185

Model 147U836H190

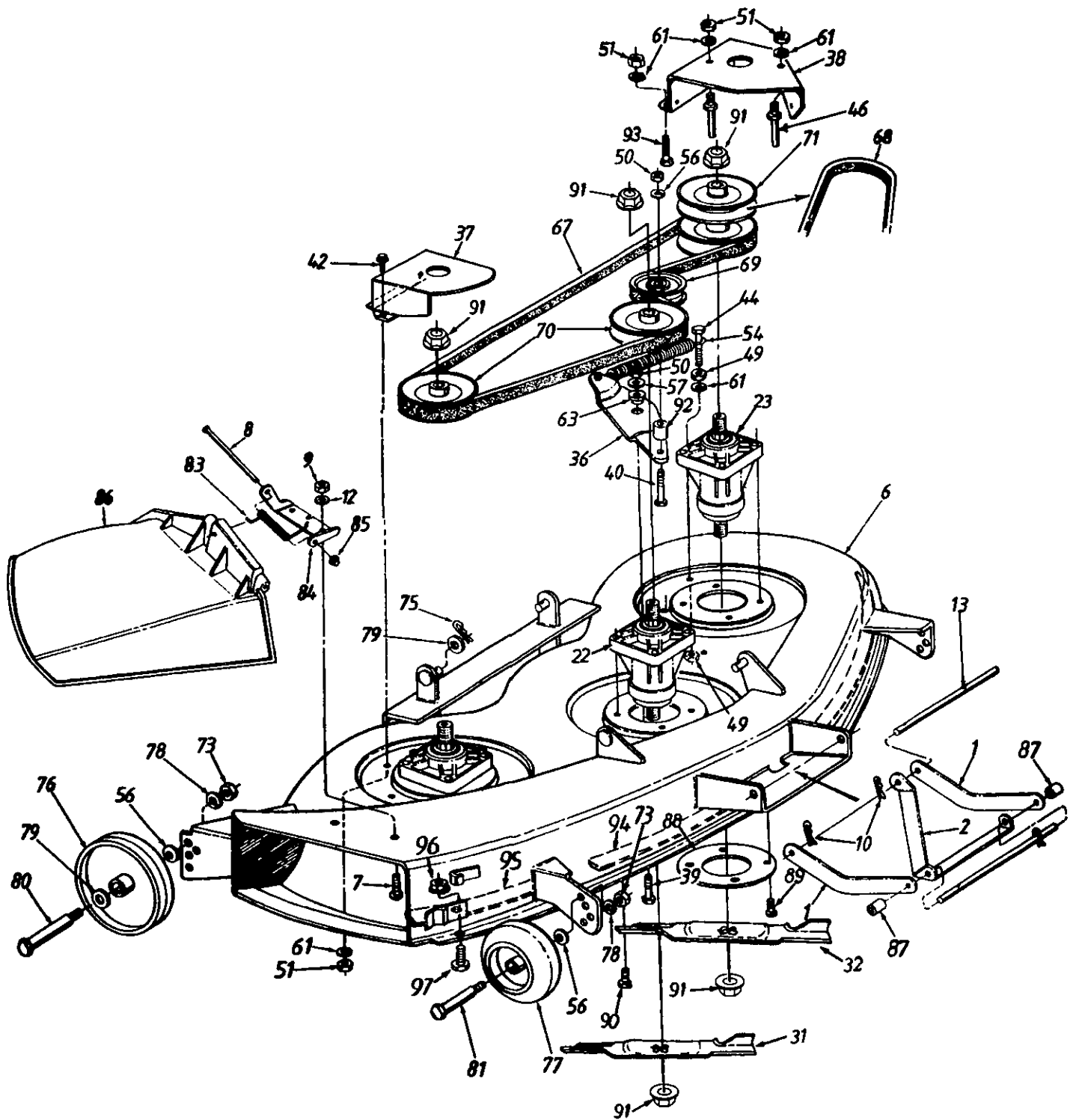



# GT-185

## Model 147U836H190

### PARTS LIST FOR 46" MOWING DECK

REF. NO.	PART NO.	CODE	DESCRIPTION	REF. NO.	PART NO.	CODE	DESCRIPTION
1	17347		Deck Stabilizer	67	754-0349		V-Belt
2	17264		Diagonal Brace	68	754-0350		V-Belt
6	683-0054		46" Deck Ass'y. Comp. (Electric Clutch)	69	756-0627		FI-Idler Pulley 3.5" O.D.
7	710-0258		Hex Bolt 1/4-20 x .62" Lg.	70	756-0969		Pulley 5.0" Dia.
8	711-0792		Hinge Pin	71	756-0603		Double Pulley 5.0" Dia.
9	712-3006		Hex Nut 1/4-20 Thd.	73	712-0798		Hex Nut 3/8-16 Thd.
10	714-0149B		Hairpin Clip	75	714-0145		Intern. Cotter Pin 3/8 Dia.
12	736-0270		Bell-Wash. 1/4" I.D.	76	734-0973		Deck Wheel 5" Dia.
13	738-0392		Deck Connecting Rod	77	734-3058B		Deck Wheel w/Insert 5" Dia.
22	618-0240	N	Spindle Ass'y. (R.H. & Center)	78	736-0169		L-Wash. 3/8" I.D.*
23	618-0241	N	Spindle Ass'y. (L.H.)	79	736-0192		FI-Wash. .531" I.D.
29	736-0119		Lock Wash. 5/16" I.D.*	80	738-0533		Shoulder Bolt .498" Dia. x 1.64" Lg.
31	742-0645	N	Blade 14.88" Lg. (Middle)	81	738-3056		Shoulder Bolt
32	742-0644	N	Blade 16.28" Lg. (R.H. & L.H.)	83	732-0602		Torsion Spring
36	17213A		Idler Bracket	84	703-1693		Hinge Mtg. Brkt.
37	17258A		Belt Cover Brkt.—R.H.	85	726-0106		Push Nut
38	783-0066A		Belt Cover—L.H.	86	731-1032		Chute Ass'y. Comp. (Incl. Ref. 8, 83, 84, 85, 86)
39	710-0152		Hex Bolt 3/8-24 x 1.0" Lg.	87	750-0932A	N	Spacer 5/8" I.D. x 7/8" O.D.
40	710-0151		Hex Bolt 3/8-24 x 2" Lg.	88	17982		Spindle Reinforcement Plate
42	710-0599		Hex Wash. Hd. Tap-Scr. 1/4-20 x .5" Lg.	89	710-0650		Hex Wash. Hd. Scr. 5/16-18 x 1" Lg.
44	710-0698		Hex Bolt 1/4-28 x 1.5" Lg.	90	710-1260		Hex Wash. Hd. Scr. 5/16-18 x .75" Lg.
46	711-0993		Belt Guard Pin 1/4" Dia.	91	712-0417A		Hex Flange Nut 5/8-18 Thd.
49	712-0138		Hex Nut 1/4-28 Thd.	92	711-0242		Spacer .38" I.D.
50	712-0241		Hex Nut 3/8-24 Thd.	93	710-0289		Hex Bolt 1/4-20 x .5" Lg.
51	712-3006		Hex Nut 1/4-20 Thd.	94	783-0141		Skirt—Center
54	732-0594A		Extension Spring 6.17" Lg.	95	783-0142		Skirt—Right Hand
56	736-0105		Bell-Wash. .38" I.D. x .88" O.D.	96	712-0271		Hex Sems Nut 1/4-20 Thd.
57	736-0331		Bell-Wash. .39" I.D. x 1.13" O.D.	97	710-0167		Carriage Bolt 1/4-20 x .5" Lg.
61	736-0329		L-Wash. 1/4" I.D.*				
63	738-0347		Shld. Spacer .625" I.D.				

\* For faster service obtain standard nuts, bolts and washers locally.  
If these items cannot be obtained locally, order by part number and  
size as shown on parts list.

# GT-205

Model 147Z836P190

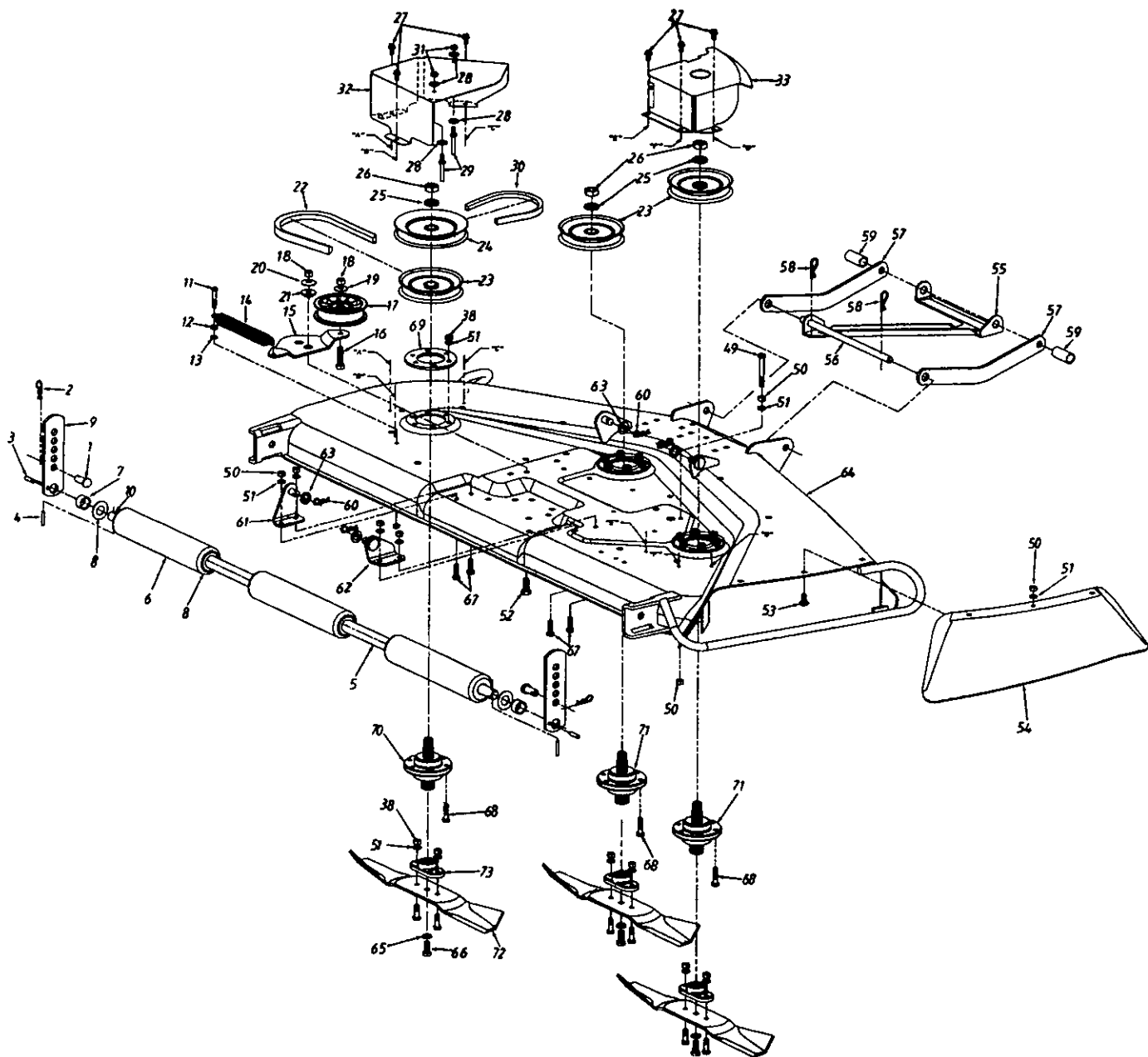

# GT-205

## Model 147Z836P190

### PARTS LIST FOR 50" MOWING DECK

REF. NO.	PART NO.	CODE	DESCRIPTION	REF. NO.	PART NO.	CODE	DESCRIPTION
1	711-0310		Clevis Pin	31	712-0287		Hex Nut 1/4-20 Thd.
2	714-0101		Hairpin Clip	32	783-0131		Belt Guard—L.H.
3	715-0108		Spring Pin 1/4" x 1" Lg.	33	783-0130		Belt Guard—R.H.
4	715-0246		Spring Pin 3/16" x 1-1/4" Lg.	38	712-0123		Hex Nut 5/16-24 Thd.
5	750-0288		Spacer .82" I.D.	49	710-0378		Hex Bolt 5/16-18 x 2.5" Lg.
6	731-0335		Deck Roller	50	712-0267		Hex Nut 5/16-18 Thd.*
7	750-0212		Spacer .75" I.D.	51	736-0119		L-Wash. 5/16" I.D.*
8	736-0188		Fl-Wash. .76" I.D. x 1.5" O.D.	52	710-0152		Hex Bolt 3/8-24 x 1" Lg.
9	12650		Height Adjuster	53	710-0451		Carr. Bolt 5/16-18 x .75" Lg.
10	738-0295		Roller Shaft	54	12649		Chute Guard
11	710-0698		Hex Bolt 1/4-28 x 1.5" Lg. (Gr. 5)	55	17264		Diagonal Brace
12	712-0138		Hex Nut 1/4-28 Thd.	56	738-0392		Connecting Rod
13	736-0329		L-Wash. 1/4" I.D.	57	17347		Stabilizer Link
14	732-0594A		Ext. Spring 7.33" Lg.	58	714-0149B		Hairpin Clip
15	783-0139		Idler Brkt.	59	750-0932A	N	Spacer 1.75" Lg.
16	710-0459		Hex Bolt 3/8-24 x 1.5" Lg.	60	714-0145		Hairpin Clip
17	756-0627		Idler Pulley	61	683-0063		Deck Hanger Brkt.—L.H.
18	712-0241		Hex Nut 3/8-24 Thd.	62	683-0062		Deck Hanger Brkt.—R.H.
19	736-0105		Bell-Wash. 3/8" I.D.	63	736-0192		Fl-Wash. 1/2" I.D. x .93" O.D.
20	736-0331		Bell-Wash. .39" I.D. x 1.13" O.D.	64	683-0060		Deck Ass'y.
21	738-0347		Shld. Spacer.625" I.D.	65	736-0217		L-Wash. 3/8" I.D.—H.D.
22	754-0291A		"V"-Belt	66	710-0877		Hex Bolt 3/8-24 x .88" Lg. (Gr. 5)
23	756-0519		Deck Pulley	67	710-1088		Hex Bolt 5/16-18 x 1" Lg.
24	756-0604		Upper Deck Pulley	68	710-0672		Hex Bolt 5/16-24 x 1-1/4" Lg. (Gr. 5)
25	736-0158		L-Wash. 5/8" I.D.				Spindle Reinforcement Plate
26	712-0318		Hex Jam Nut 5/8-18 Thd.	69	14249A		Spindle Ass'y. (L.H.)
27	710-0599		Hex Wash. Hd. Scr. 1/4-20 x .5" Lg.	70	618-0119		Spindle Ass'y. (R.H. & Center)
				71	618-0118		Blade
28	736-0270		Bell-Wash. 1/4" I.D.	72	742-0171B		Blade Adapter
29	711-0747		Belt Guard Pin	73	748-0300		Hex Bolt 5/16-24 x 1" Lg.
30	754-0364		"V"-Belt	74	710-0888		



# MANUFACTURER'S LIMITED WARRANTY FOR:



For TWO YEARS from the date of retail purchase within the United States of America, its possessions and territories, MTD Products at its option, repair or replace, for the original purchaser, free of charge, any part or parts found to be defective in material or workmanship. This warranty covers units which have been operated and maintained in accordance with the owner's instructions furnished with the unit, and which have not been subject to misuse, abuse, neglect, accident, improper maintenance or alteration.

**NORMAL WEAR PARTS** or components thereof are subject to separate terms as noted below in the "No Fault Ninety Day Consumer Warranty" clause. Commercial use is subject to the terms listed above, and is covered for a period of 90 days from the date of purchase.

**TWO YEAR CONSUMER WARRANTY ON NORMAL WEAR PARTS WITH NINETY DAY NO FAULT PROTECTION:** All normal wear parts failures will be covered on this product for a period of 90 days regardless of cause. After 90 days, but within the two year period, normal wear parts failures will be covered if caused by defects in material or workmanship. Normal wear parts are defined as belts, blades, blade adapters, grass bags, rider deck wheels, seats, snow thrower skid shoes, shave plates and tires.

**HOW TO OBTAIN SERVICE:** Warranty service is available, with proof of purchase, through your local authorized service dealer. To locate the dealer in your area, please check the yellow pages or contact the Customer Service Department of MTD Products, P O Box 361131, Cleveland, Ohio 44136-0019. Phone (330) 225-8883. The return of a complete unit will not be accepted by the factory unless prior written permission has been extended by the Service Department of MTD Products.

**TRANSPORTATION CHARGES:** Transportation charges for the movement of any power equipment unit or attachment are the responsibility of the purchaser. Transportation charges for any parts submitted for replacement under this warranty must be paid by the purchaser unless such return is requested by MTD Products.

**UNITS EXPORTED OUT OF THE UNITED STATES:** MTD Products does not extend any warranty for products sold or exported outside of the United States of America, its possessions and territories, except those sold through MTD Products' authorized channels of export distribution.

## OTHER WARRANTIES:

1. The engine or component parts thereof carry separate warranties from their manufacturers. Please refer to the applicable manufacturer's warranty on these items.
2. Batteries are covered by a 90-day replacement warranty.
3. Log splitter pumps, valves and cylinders or component parts thereof are covered by a one year warranty.
4. All other warranties, express or implied, including any implied warranty of merchantability or fitness for a particular purpose, are hereby expressly disclaimed in their entirety.
5. The provisions as set forth in this warranty provide the sole and exclusive remedy of MTD Products obligations arising from the sales of its products. MTD Products will not be liable for incidental or consequential loss or damage.

**HOW STATE LAW RELATES TO THIS WARRANTY:** This limited warranty gives you specific legal rights, and you may also have other rights which vary from state to state. Certain disclaimers are not allowed in some states and therefore they may not apply to you under all circumstances.

**NOTE:** This warranty does not cover set-up, routine maintenance items such as lubricants, filters, blade sharpening and tune-ups, or adjustments such as brake adjustments. Nor does this warranty cover normal deterioration of the exterior finish due to use or exposure.



**FOR THE DEALER NEAREST YOU  
CALL  
1-800-9-4WHITE**

The only way to ensure the performance of your product is to use original equipment parts and accessories. MTD Products designs and engineers quality parts to exacting specifications. When you substitute, you take a chance on quality, reliability, safety and performance. Use MTD products original equipment parts—See your local White Outdoor dealer!



**WARNING:** The Engine Exhaust from this product contains chemicals known to the State of California to cause cancer, birth defects or other reproductive harm.