

# OWNER'S GUIDE

• ASSEMBLY • OPERATION • MAINTENANCE •

## FOUR WHEEL STEER LAWN TRACTORS

### Model Series 610 thru 619 Lawn Tractors

#### IMPORTANT!

Record the **Model No.** and **Mfg. Code** which appear on your unit in the space below. You **must** have these numbers, along with the date of purchase, in order to receive warranty or service.

**MEETS ANSI SAFETY STANDARDS**

MODEL NO.

MFG. CODE

**Important:  
Read Safety Rules  
and Instructions Carefully**



Made  
in  
AMERICA

**WARNING:** This unit is equipped with an internal combustion engine and should not be used on or near any unimproved forest-covered, brush-covered or grass-covered land unless the engine's exhaust system is equipped with a spark arrester meeting applicable local or state laws (if any). If a spark arrester is used, it should be maintained in effective working order by the operator.

In the State of California the above is required by law (Section 4442 of the California Public Resources Code). Other states may have similar laws. Federal laws apply on federal lands. A spark arrester for the muffler is available through your nearest engine authorized service dealer or contact the service department, P.O. Box 368022, Cleveland, Ohio 44136-9722.

# IMPORTANT

## SAFE OPERATION PRACTICES



THIS SYMBOL POINTS OUT IMPORTANT SAFETY INSTRUCTIONS WHICH, IF NOT FOLLOWED, COULD ENDANGER THE PERSONAL SAFETY AND/OR PROPERTY OF YOURSELF AND OTHERS. READ AND FOLLOW ALL INSTRUCTIONS IN THIS MANUAL BEFORE ATTEMPTING TO OPERATE YOUR UNIT. WHEN YOU SEE THIS SYMBOL—  **HEED ITS WARNING.**



**DANGER:** This cutting machine is capable of amputating hands and feet and throwing objects. Failure to observe the following safety instructions could result in serious injury or death.

### I. GENERAL OPERATION

1. Read, understand, and follow all instructions in the manual and on the machine before starting. Keep this manual in a safe place for future reference and for ordering replacement parts.
2. Only allow responsible adults familiar with the instructions to operate the machine. Know controls and how to stop the machine quickly.
3. Do not put hands or feet under cutting deck or near rotating parts.
4. Clear the area of objects such as rocks, toys, wire, etc. which could be picked up and thrown by the blade. A small object may have been overlooked and could be accidentally thrown by the mower in any direction and cause injury to you or a bystander. Always wear safety glasses or eye shields during operation or while performing an adjustment or repair, to protect eyes from foreign objects. Stop the blade(s) when crossing gravel drives, walks or roads.
5. Be sure the area is clear of other people before mowing. Stop machine if anyone enters the area.
6. Never carry passengers.
7. Disengage blade(s) before shifting into reverse and backing up. Always look down and behind before and while backing.
8. Be aware of the mower and attachment discharge direction and do not point it at anyone. Do not operate the mower without either the entire grass catcher or the chute guard in place.
9. Slow down before turning. Operate the tractor smoothly. Avoid erratic operation and excessive speed.
10. Never leave a running machine unattended. Always turn off blade(s), place transmission in neutral, set park brake, stop engine and remove key before dismounting.
11. Turn off blade(s) when not mowing.
12. Stop engine and wait until blade(s) comes to a complete stop before (a) removing grass catcher or unclogging chute, or (b) making any repairs, adjusting or removing any grass or debris.
13. Mow only in daylight or good artificial light.
14. Do not operate the machine while under the influence of alcohol or drugs.
15. Watch for traffic when operating near or crossing road ways.
16. Use extra care when loading or unloading the machine into a trailer or truck. This unit should not be driven up or down a ramp onto a trailer or truck under power, because the unit could tip over, causing serious personal injury. The unit must be pushed manually to load or unload properly.
17. Never make a cutting height adjustment while engine is running if operator must dismount to do so.
18. Wear sturdy, rough-soled work shoes and close-fitting slacks and shirts. Do not wear loose fitting clothes or jewelry. They can be caught in moving parts. Never operate a unit in bare feet, sandals, or sneakers.
19. Check overhead clearance carefully before driving under power lines, wires, bridges or low hanging tree branches, before entering or leaving buildings, or in any other situation where the operator may be struck or pulled from the unit, which could result in serious injury.
20. Disengage all attachment clutches, thoroughly depress the brake pedal, and shift into neutral before attempting to start engine.

### II. SLOPE OPERATION

Slopes are a major factor related to loss of control and tip-over accidents which can result in severe injury or death. All slopes require extra caution. If you cannot back up the slope or if you feel uneasy on it, do not mow it.

#### DO:

Mow up and down slopes, not across.  
Remove obstacles such as rocks, limbs, etc.  
Watch for holes, ruts or bumps. Uneven terrain could overturn the machine. **Tall grass can hide obstacles.**  
Use slow speed. Choose a low enough gear so that you will not have to stop or shift while on the slope. Always keep tractor in gear when going down slopes to take advantage of engine braking action.  
Follow the manufacturer's recommendations for wheel weights or counterweights to improve stability.  
Use extra care with grass catchers or other attachments. These can change the stability of the machine.  
Keep all movement on the slopes **slow** and **gradual**. Do not make sudden changes in speed or direction. Rapid engagement or braking could cause the front of the machine to lift and rapidly flip over backwards which could cause serious injury.  
Avoid starting or stopping on a slope. If tires lose traction, disengage the blade(s) and proceed slowly **straight** down the slope.  
For your safety, use the slope gauge included as part of this manual to measure slopes before operating this unit on a sloped or hilly area. If the slope is greater than 15° as shown on the slope gauge, do not operate this unit on that area or serious injury could result.

#### DO NOT:

**Do not** turn on slopes unless necessary; then, turn slowly and gradually downhill, if possible.  
**Do not** mow near drop-offs, ditches or embankments. A wheel over the edge or an edge caving in could cause sudden overturn.  
**Do not** mow on wet grass. Reduced traction could cause sliding.  
**Do not** try to stabilize the machine by putting your foot on the ground.  
**Do not** use grass catcher on steep slopes.

### III. CHILDREN

Tragic accidents can occur if the operator is not alert to the presence of children. Children are often attracted to the machine and the mowing activity. **Never** assume that children will remain where you last saw them.

1. Keep children out of the mowing area and in watchful care of an adult other than the operator.
2. Be alert and turn machine off if children enter the area.
3. Before and when backing, look behind and **down** for small children.
4. Never carry children. They may fall off and be seriously injured or interfere with the safe machine operation.
5. Never allow children under 14 years old to operate the machine. Children 14 years and over should only operate machine under close parental supervision and proper instruction.
6. Use extra care when approaching blind corners, shrubs, trees or other objects that may obscure vision.

#### IV. SERVICE

1. Use extra care in handling gasoline and other fuels. They are flammable and vapors are explosive.
  - a. Use only an approved container.
  - b. Never remove gas cap or add fuel with the engine running. Allow engine to cool at least two minutes before refueling. Do not smoke.
  - c. Never refuel the machine indoors.
  - d. Never store the machine or fuel container inside where there is an open flame, or spark, such as a water heater, space heater, clothes dryer and the like.
2. Never run a machine inside a closed area.
3. Check frequently and keep nuts and bolts, especially blade attachment bolts, tight and keep equipment in safe working condition.
4. Never tamper with safety devices. Check their proper operation regularly. Use all guards as instructed in this manual.
5. To reduce fire hazard, keep machine free of grass, leaves or

other debris build-up. Clean up oil or fuel spillage. Allow machine to cool before storing.

6. Stop and inspect the equipment for damage if you strike an object. Repair, if necessary, before re-starting and operating the machine.
7. Never make adjustments or repairs with the engine running.
8. Grass catcher components are subject to wear, damage and deteriorate, which could expose moving parts or allow objects to be thrown. Frequently, check components and replace with manufacturer's recommended parts when necessary.
9. Mower blades are sharp and can cut. Wrap the blade(s) or wear gloves and use extra caution when servicing blade(s).
10. Check brake operation frequently. Adjust and service as required.
11. Muffler, engine, and belt guards become hot during operation and can cause a burn. Allow to cool down before touching.
12. Do not change the engine governor settings or overspeed the engine.



**DANGER:** Your unit was built to be operated according to the rules for safe operation in this manual. As with any type of power equipment, carelessness or error on the part of the operator can result in serious injury. If you violate any of these rules, you may cause serious injury to yourself or others.

## ASSEMBLY INSTRUCTIONS

This owner's manual covers various models of lawn tractors. The units illustrated may vary slightly from your unit. Follow only those instructions which pertain to your model lawn tractor.

**IMPORTANT:** After assembly, service engine with gasoline, and check oil level as instructed in the separate engine manual packed with your unit.

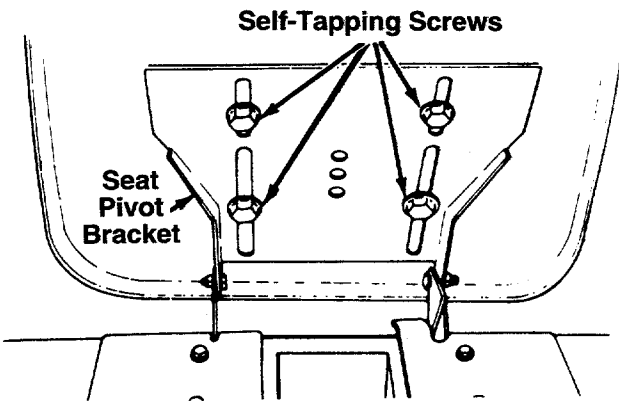

FIGURE 1.

**NOTE:** Reference to right or left hand side of the unit is observed from the driver's seat, facing forward.

### UNPACKING

1. Remove the lawn tractor from the carton as follows. Open the top flaps. The loose parts (include the battery fluid, steering wheel with steering cap attached and chute deflector) are on the seat and wrapped in plastic. Remove all carton inserts. Cut the front corners of the carton. If you have a 46" deck, carefully remove the deck from the side of the carton. Make certain brake is released, and push the unit out of the carton.
2. The seat has been mounted backward for shipping purposes. Carefully cut and remove the plastic wrap. Remove the loose parts from the seat.

### ← ASSEMBLING THE SEAT

Remove the hex self-tapping screws which secure the seat to the seat pivot bracket. Turn the seat around and place in position against the seat pivot bracket, lining up the slotted holes in the pivot bracket with the holes in the seat. Select desired position for the seat, and secure with hex self-tapping screws. See figure 1.

### BATTERY INFORMATION



#### WARNING

- A. Battery acid must be handled with great care as contact with it can burn and blister the skin. It is also advisable to wear protective clothing (goggles, rubber gloves and apron) when working with it.\*
- B. Should battery acid accidentally splatter into the eyes or onto the face, rinse the affected area immediately with clean cold water. If there is any further discomfort, seek prompt medical attention.
- C. If acid spills on clothing, first dilute it with clean water, then neutralize with a solution of ammonia/water or baking soda/water.

- D. Since battery acid is corrosive, do not pour it into any sink or drain. Before discarding empty electrolyte containers, rinse them with a neutralizing solution.
- E. NEVER connect or disconnect charger clips to battery while charger is turned on as it can cause sparks.
- F. Keep all lighted materials (cigarettes, matches, lighters) away from the battery as the hydrogen gas generated during charging can be combustible.
- G. As a further precaution, only charge the battery in a well-ventilated area.

**\*Always shield eyes, protect skin and clothing when working near batteries.**

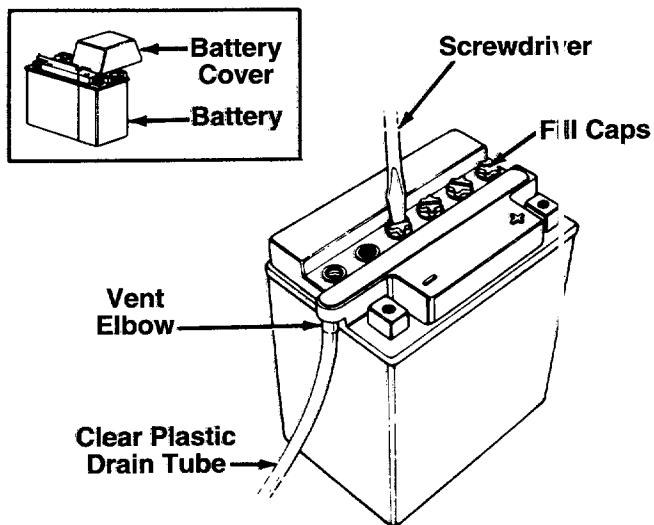

FIGURE 2.

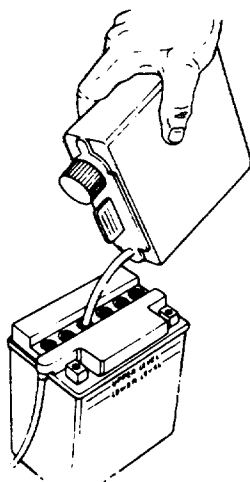

FIGURE 3.

## ACTIVATING THE BATTERY

Do not activate battery (fill with battery acid) until battery is actually placed in service. Be certain to read previous warnings before activating the battery.

1. Lift the seat. Remove the battery cover by pressing in on the sides and lifting up. See figure 2, inset. Remove the battery from the rear frame.
2. Open the battery pack. Be careful not to puncture the box. It contains the **battery fluid (acid)** in a plastic container and one short plastic tube.
3. Place the battery on a table or workbench. Make certain the long plastic drain tube is in place on the vent elbow.
4. Remove the six fill caps from the top of the battery. Be careful not to damage the fill caps. See figure 2.
5. Place the battery fluid container on the table or workbench. Carefully cut off tip of the spout and attach the short plastic tube provided. Do not squeeze the container when cutting tip.
6. Fill each battery cell slowly and carefully to the UPPER LEVEL line marked on battery. See figure 3. Use caution as the acid level will rise rapidly after the bottom of the cell is filled.
7. **Allow battery to stand for 30 minutes** with the fill caps removed, while the plates absorb acid.

**NOTE:** You can continue assembling the lawn tractor while battery is standing for 30 minutes (after filling with acid), and later while you are charging the battery.

## CHARGE THE BATTERY

**IMPORTANT:** To obtain the maximum life from your battery, it **MUST BE CHARGED** prior to initial use.

1. Check the acid level in each cell. If necessary, refill each cell with **battery acid** to the UPPER LEVEL line on battery. Replace the fill caps.
2. Before discarding the empty container, neutralize any residue with baking soda and rinse container with water. Puncture container several times before discarding.
3. **CHARGE THE BATTERY** after the 30 minute standing period. Use a 12-volt automotive type battery charger to SLOW CHARGE THE BATTERY (DO NOT FAST CHARGE). DO NOT use a charger rated higher than 10 amps. **Charge the battery** for a minimum of 2 hours or until battery is fully charged.

**NOTE:** The information listed above is for initial charge. Refer to the Maintenance section of this manual for battery care and charging instructions to obtain the maximum life from your battery.

**IMPORTANT:** After the battery has been charged, add only distilled water. DO NOT add acid.



**DANGER**

**Battery contains sulfuric acid. Refer to warning on page 3.** Antidote: EXTERNAL—Flush with water. INTERNAL—Drink large quantities of water or milk. Follow with milk of magnesia, beaten eggs or vegetable oil. Call physician immediately. EYES: Flush with cool water for at least 15 minutes; then get prompt medical attention.

**Since batteries produce explosive gases keep all lighted materials (cigarettes, lighters, matches, etc.) away.** Be sure to charge battery only in well-ventilated areas. Make certain venting path of battery (drain tube) is always open.

**KEEP BATTERIES  
OUT OF THE REACH OF CHILDREN!**

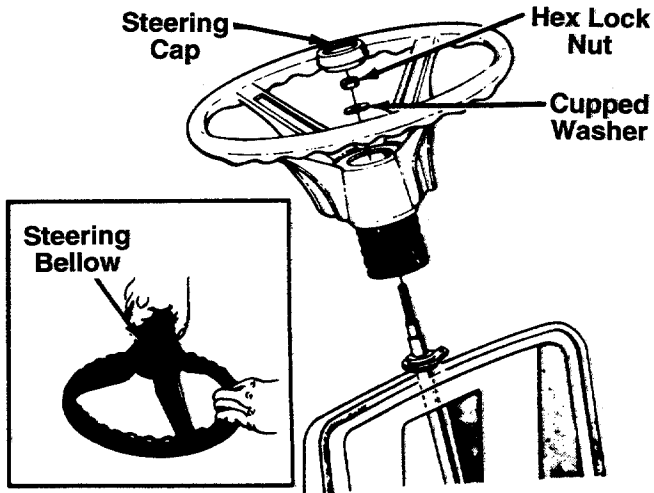

FIGURE 4.

### ATTACHING THE STEERING WHEEL

1. Remove the hex lock nut and cupped washer from the steering shaft, and remove the steering bellow. Pry the steering cap off the center of the steering wheel.
2. Attach one end of steering bellow to the steering wheel as shown in figure 4, inset.
3. Position the front wheels of the tractor so they are pointing straight forward.
4. Place the steering wheel and steering bellow over the steering shaft, positioning steering wheel as desired.
5. Place the washer with the cupped side down over the steering shaft. Secure with hex lock nut. See figure 4.
6. Place the steering cap over the center of the steering wheel and seat it with your hand.

### ATTACHING THE CHUTE DEFLECTOR

**NOTE:** If you have a 30" deck, attach the chute deflector as instructed in the separate deck manual packed with your unit.

The chute deflector must be attached to the right side of the deck so that it covers the chute opening.



**WARNING:** Do not operate your unit unless the chute deflector has been properly installed.

1. Make certain deck is raised to its highest position (lift lever pulled all the way back).
2. Remove the truss machine screws, cupped washers and hex nuts which are attached to the deck next to the chute opening.
3. Place the chute deflector in position as shown in figure 5. Secure with hardware just removed. Cupped side of washers goes against the chute deflector.

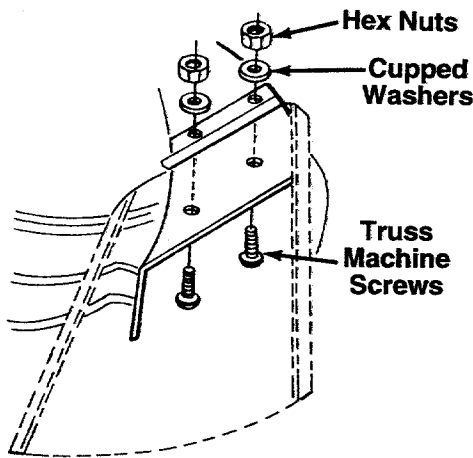

FIGURE 5.

### LEVELING THE DECK

With unit on hard, level surface, measure the distance from the bottom edge of the center of the left side of deck to the ground. Measure the same distance on the center of the right side of the deck (just behind the chute area on side discharge units). Or, place the blades in a straight line, and measure the distance from the outside edge of the blade tips to the ground.

If adjustment is needed, proceed as follows.

1. Remove the hairpin clip and flat washer from the bottom of the adjustable lift link on the left side of the deck. (Hairpin clip and flat washer are on the inside of the lift link.)
2. Pull the adjustable lift link out of the deck hanger channel. See figure 6.
3. Turn the adjustable lift link up or down as necessary to level the deck. Usually only one or two turns are needed.

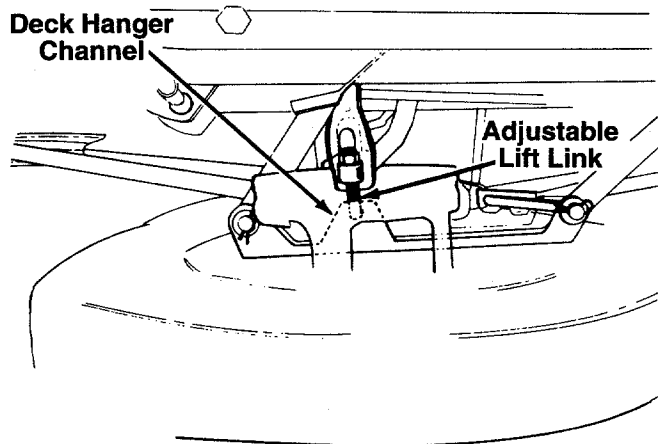

FIGURE 6.

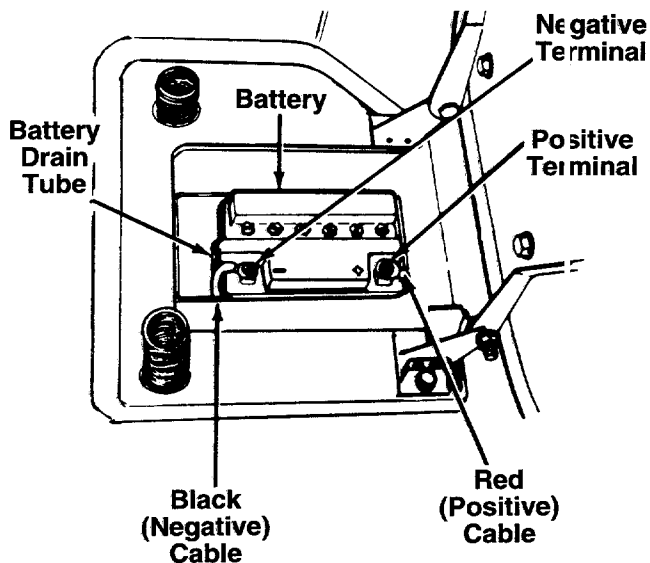

FIGURE 7.

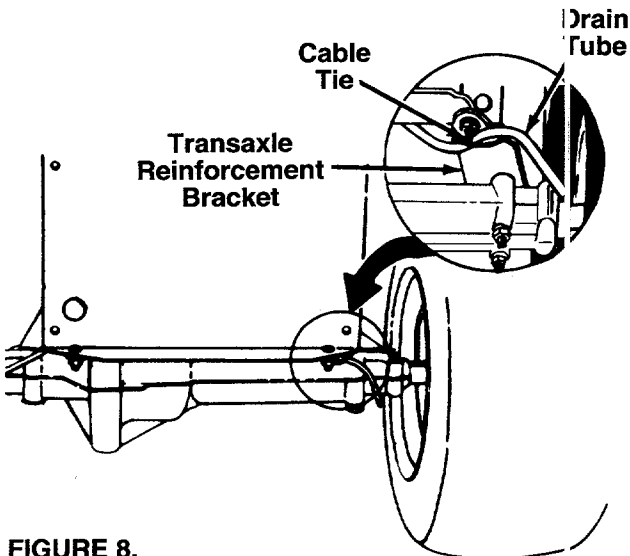

FIGURE 8.

4. Insert the end of the adjustable lift link into the hole in the deck hanger channel. Recheck the adjustment as instructed above. Readjust if necessary.
5. When deck is level, secure the end of the adjustable lift link with flat washer and hairpin clip.

### TIRE PRESSURE

The tires on your unit may be over-inflated for shipping purposes. Reduce the tire pressure before operating the unit. Recommended operating tire pressure is approximately 12 p.s.i. (check sidewall of tire for tire manufacturer's recommended pressure).



**WARNING: Maximum tire pressure under any circumstances is 30 p.s.i. Equal tire pressure should be maintained on all tires.**

### ← INSTALLING THE BATTERY

1. Raise the seat.
2. Make certain the positive cable (heavy red wire) and negative cable (heavy black wire) are routed outside the battery opening.
3. Place the battery inside the opening so that the positive terminal is toward the front of the unit. See figure 7. Route the battery drain tube down beside the battery.
4. Remove the hex bolt from the positive (+) terminal. Place the positive cable on the positive terminal. See figure 7. Secure with hex bolt. Be careful not to lose the nut inside the terminal.
5. Secure the negative cable to the negative (-) terminal in the same manner. Replace the battery cover over the positive terminal. Lower the seat.
6. Insert the drain tube through the cable tie which is attached to the transaxle reinforcement bracket on the **right** side of the unit. See figure 8. Be certain drain tube is routed away from the wheel rim. Pull on end of cable tie to tighten (do not collapse drain tube). Trim excess end of cable tie.



## CONTROLS

### IGNITION SWITCH

The ignition switch is located on the dashboard. Turn the key to the START position to start the engine. When the engine is running, leave the key in the ON position. To stop the engine, turn the key to the OFF position. See figure 9.



**WARNING: Remove the key from the tractor when the tractor is not in use to prevent accidental starting.**

### THROTTLE CONTROL

The throttle control is located on the left side of the dashboard and is used to regulate the engine speed. See figure 9. The engine should be operated at full throttle (FAST) when operating the mower.

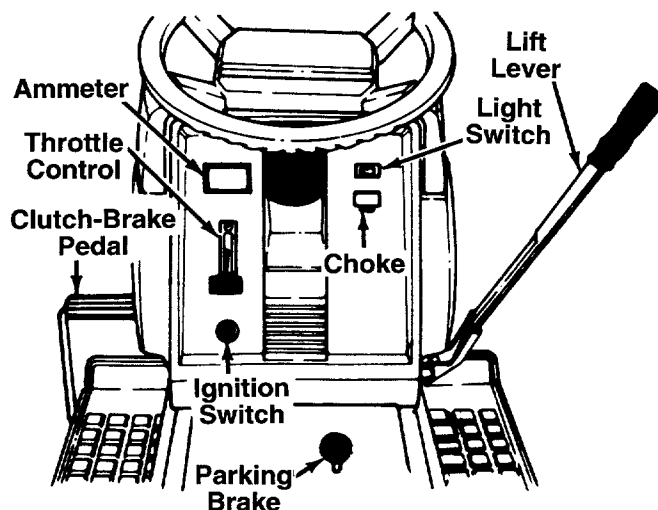

FIGURE 9.

## CHOKE CONTROL

The choke control is located on the right side of the dashboard and is operated manually. Details for the choke operation are covered in the separate engine manual packed with your unit. See figure 9.

## LIGHT SWITCH

The head lamps are operated by pushing the light switch located on the dashboard. The head lamps will only operate when the engine is running. See figure 9.

## AMMETER

The ammeter registers the rate of battery charge or discharge. The ammeter will register on the discharging side when starting the engine. It should register on the opposite side (charging) when the engine is running in the fast position until the battery is completely charged. With a fully charged battery or with the engine idling, the ammeter will not show a charge. See figure 9.

## CLUTCH-BRAKE PEDAL

The clutch-brake pedal is located on the left side of the tractor. See figure 9. Depressing the clutch-brake pedal partway disengages the clutch. Pressing the pedal all the way down disengages the clutch and engages the disc brake.

**NOTE:** The clutch-brake pedal must be depressed to start the engine.

## SHIFT LEVER

The shift lever is located on the right fender and has three positions, FORWARD, NEUTRAL and REVERSE. See figure 10. The clutch-brake pedal must be depressed and the lawn tractor must not be moving when shifting gears. Do not force the shift lever. Release the clutch-brake pedal slightly to line up the shifting collar in the transmission. Then try to shift gears.

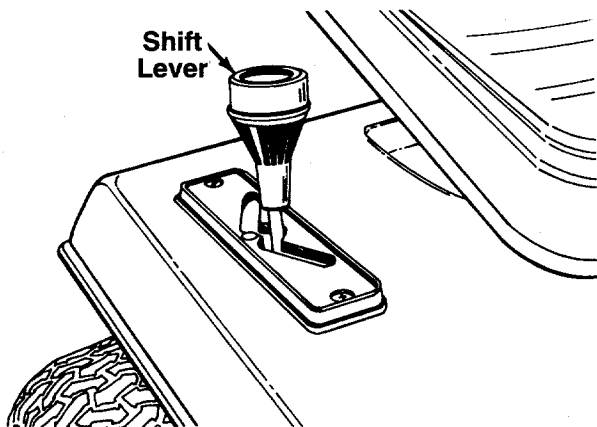

FIGURE 10.

## PARKING BRAKE

To set the parking brake, depress the clutch-brake pedal and pull up the parking brake knob. It will stay in the raised position. To release the parking brake, depress and release the clutch-brake pedal. See figure 9.

**NOTE:** The parking brake must be set if the operator leaves the seat with the engine running.

## SPEED CONTROL LEVER

The speed control lever is located on the left fender. It allows you to regulate the ground speed of the lawn tractor. See figure 11. To select the ground speed, depress clutch pedal. Push speed control lever outward and move backward to slow lawn tractor, move forward to increase speed. When desired speed has been obtained, release lever in that position. Whenever clutch is engaged, unit will automatically go to the pre-set speed.

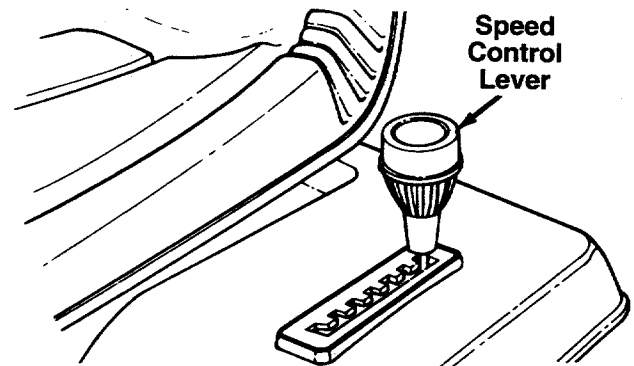

FIGURE 11.

## CUTTING CONTROLS

### A. LIFT LEVER

The lift lever is used to raise and lower the cutting deck and to engage and disengage the blades. Pulling it all the way back and locking it disengages the blades.

**NOTE:** The lift lever must be in the disengaged position when starting the engine, when shifting into reverse or if the operator leaves the seat.

### B. DECK LIFT INDICATOR (Optional Equipment)

If so equipped, the deck lift indicator marks the position being used for the lift lever. Select the lift lever position desired, press the indicator lever outward, move it to the position immediately below the lift lever and release the indicator lever. See figure 12.

### C. SETTING THE CUTTING HEIGHT

1. Select the position for the lift lever which gives the desired cutting height. Move the deck lift indicator (if so equipped) so that the lift lever can be returned to the same position after it is raised.

2. Move the deck wheels (if so equipped) to the hole location so the wheels are 1/4 to 1/2 inch above the ground.

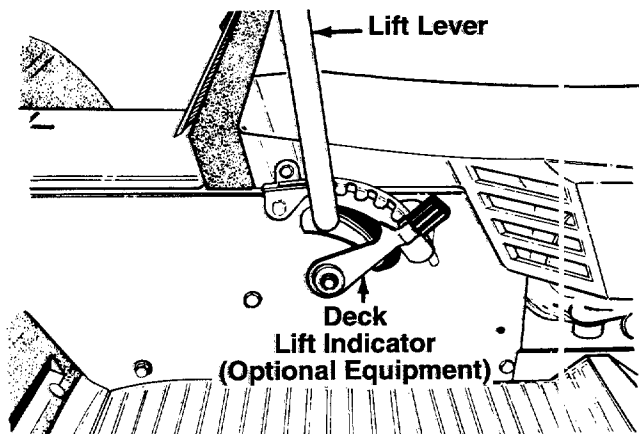

FIGURE 12.

## OPERATION



### WARNING

#### AVOID SERIOUS INJURY OR DEATH

- GO UP AND DOWN SLOPES, NOT ACROSS. • AVOID SUDDEN TURNS.
- DO NOT OPERATE THE UNIT WHERE IT COULD SLIP OR TIP.
- IF MACHINE STOPS GOING UPHILL, STOP BLADE(S) AND BACK DOWNHILL SLOWLY.
- DO NOT MOW WHEN CHILDREN OR OTHERS ARE AROUND.
- NEVER CARRY CHILDREN.
- LOOK DOWN AND BEHIND BEFORE AND WHILE BACKING.
- KEEP SAFETY DEVICES (GUARDS, SHIELDS, AND SWITCHES) IN PLACE AND WORKING.
- REMOVE OBJECTS THAT COULD BE THROWN BY THE BLADE(S).
- KNOW LOCATION AND FUNCTION OF ALL CONTROLS.
- BE SURE BLADE(S) AND ENGINE ARE STOPPED BEFORE PLACING HANDS OR FEET NEAR BLADE(S).
- BEFORE LEAVING OPERATOR'S POSITION, DISENGAGE BLADE(S), PLACE THE SHIFT LEVER IN NEUTRAL, ENGAGE BRAKE LOCK, SHUT ENGINE OFF AND REMOVE KEY.

READ OPERATOR'S MANUAL

### GAS AND OIL FILL-UP

Check oil level and add if necessary. Service the engine with gasoline as instructed in the separate engine manual packed with your tractor. Read instructions carefully.

**IMPORTANT:** Your tractor is shipped with oil; however, you **must** check the oil level before operating. Be careful not to overfill.



**WARNING:** Never fill fuel tank indoors, with engine running or while engine is hot.

### STARTING THE ENGINE

**IMPORTANT:** This unit is equipped with a **safety interlock system** for your protection. The purpose of the safety interlock system is to prevent the engine from cranking or starting unless the clutch-brake pedal is depressed and the lift lever is in the disengaged position. In addition, the lift lever must be in the disengaged position when the unit is put into reverse or the engine will shut off. If the operator leaves the seat with the lift lever engaged and/or without setting the parking brake, the engine will shut off.



**WARNING:** Do not operate the lawn tractor if the interlock system is malfunctioning because it is a safety device, designed for protection.

1. Place the lift lever in the DISENGAGED position.
2. Depress the clutch-brake pedal and set the parking brake.
3. Place the shift lever in the NEUTRAL position.
4. Set the throttle control in the FAST position.
5. Pull out the choke control (a warm engine may not require choking).
6. Turn the ignition key to the right to the START position. After the engine starts, release the key. It will return to the ON position.
7. Slowly push in the choke as the engine warms up.

### STOPPING THE ENGINE

Turn the ignition key to the left to the OFF position. Remove the key to prevent accidental starting.

**IMPORTANT:** If you strike a foreign object, stop the engine. Remove wire from spark plug, thoroughly inspect the unit for any damage, and repair the damage before restarting and operating the mower.

**NOTE:** If any problems are encountered, refer to the *Trouble Shooting Chart* on page 17.

### OPERATING THE LAWN TRACTOR



**WARNING:** Before operating your four wheel steer lawn tractor, be certain to read the next section, "Steering the Lawn Tractor." Operate your tractor in an open area when operating for the first time.

1. Set the desired cutting height.
2. Start the engine as instructed previously.
3. Move throttle control to full throttle to prevent strain on the engine and to operate attachments.
4. Place the shift lever in either the FORWARD or REVERSE position. Place the speed control lever in desired position. Use first speed position when operating the tractor for the first time.





**WARNING:** Look to the rear before backing up.

5. Release the parking brake by depressing the clutch-brake pedal. Release clutch-brake pedal slowly to put unit into motion.
6. The lawn tractor is brought to a stop by depressing the clutch-brake pedal.

**NOTE:** When operating the unit initially, there will be little difference between the highest two speeds until after the belts have seated themselves into the pulleys during the break-in period.

Be sure that the lawn is clear of stones, sticks, wire, or other objects which could damage tractor or engine. For best results and to insure more even grass distribution, do not mow when lawn is excessively wet.



**WARNING:** Before leaving the operator's position for any reason, disengage the blades, place the shift lever in neutral, engage the parking brake, shut engine off and remove the key.

When stopping the unit to empty a grass bag, etc., follow the instructions above. This procedure will also eliminate "browning" the grass, which is caused by hot exhaust gases from a running engine.

If unit stalls with speed control in high speed, or if unit will not operate with speed control lever in a low speed position, proceed as follows.

1. Place shift lever in NEUTRAL.
2. Restart engine.
3. Place speed control lever in HIGH speed position.
4. Release clutch-brake pedal fully.
5. Depress clutch-brake pedal.
6. Place speed control lever in desired position.
7. Place shift lever in either FORWARD or REVERSE, and follow normal operating procedures.

### STEERING THE LAWN TRACTOR

Your four wheel steering lawn tractor is designed for optimum maneuverability. It is important to understand how it operates before using the lawn tractor.

If the wheels are pointing straight forward and the steering wheel is turned less than approximately 45°, only the front wheels turn. See figure 13A. When the steering wheel is turned sharply (more than approximately 45°), the rear wheels also turn, but in the opposite direction as the front wheels to provide a very small turning radius. See figure 13B.

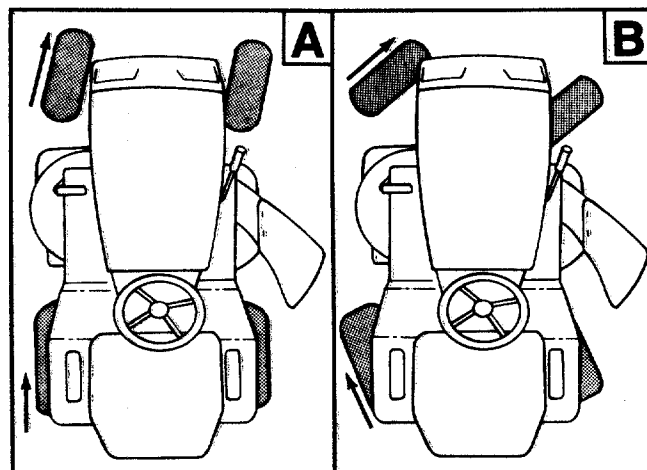

FIGURE 13.

**The important point is this:** When operating the lawn tractor beside a wall or fence, against or on top of a curb, driving around an object, or in any other similar situation, turn the steering wheel gradually to pull away from the object or curb so the rear of the tractor does not swing out and hit the object or go over the curb.



**WARNING:** If operating this lawn tractor near a drop-off in the ground, do not make a sharp turn. The rear wheel turns outward (see figure 13B) and could lose ground contact, which could cause the vehicle to tip over.

### OPERATING THE CUTTING BLADES

The cutting blades may be engaged while the lawn tractor is moving or standing still. DO NOT engage the cutting blades abruptly as the sudden belt tension on the pulley may cause the engine to stall.



**WARNING:** Keep feet and hands away from the discharge opening, the blades or any part of the deck. When the unit is used for other than mowing operations, the blade drive should be disengaged.

Move the lift lever into the DISENGAGED position to raise the deck and disengage the blades.

### GRASS COLLECTOR AVAILABLE

GRASS COLLECTOR Model 190-063 is available as optional equipment.



**WARNING:** The mower should not be operated without the entire grass catcher or chute deflector in place.

**NOTE:** Under normal usage bag material is subject to wear, and should be checked periodically. Be sure any replacement bag complies with the mower manufacturer's recommendations. For replacement bags, use only factory authorized replacement bag.

# ADJUSTMENTS

## SEAT ADJUSTMENT

The seat may be adjusted to different positions. Refer to seat installation section of assembly instructions.

## DECK LEVELING ADJUSTMENT

If an uneven cut is obtained, the deck may be leveled by following instructions at end of assembly section.

## CUTTING DECK ENGAGEMENT ADJUSTMENT

The cutting deck engagement may be adjusted to make certain deck is disengaged when lift lever is in the disengaged position, or to obtain more drive in the cutting positions. Correct adjustment as follows:

With the engine off, place the lift lever in the highest cutting position (first position). Remove the cotter pin and flat washer which secure the disengagement rod to the stabilizer shaft assembly. See figure 14. Shorten the rod by threading it in until the ferrule is against the back of the slot in the lift shaft assembly, and the rod lines up with the hole in the stabilizer shaft. For more belt tension the disengagement rod must be lengthened. To decrease belt tension the disengagement rod must be shortened.

Check the adjustment by placing the lift lever in the disengaged position. The deck should move up and forward, allowing the belt to become loose. Start and test for disengagement. Repeat procedure as necessary.

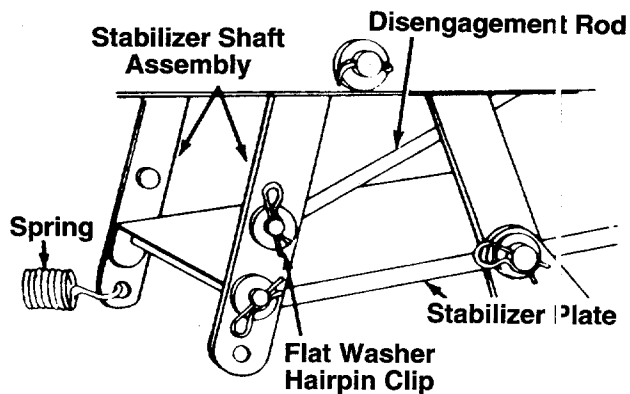

FIGURE 14.—42" Deck Shown

## SPEED CONTROL ADJUSTMENT

**NOTE:** When operating the unit initially or after replacing the belts, there will be little difference between the highest two speeds until after the belts have gone through a break-in period and have seated themselves into the pulleys.

To adjust the speed control, proceed as follows.

1. Start the engine.
2. Place the shift lever in Neutral position.

3. Place the speed control lever in high speed position.
4. Release the clutch-brake pedal completely, then slowly depress the pedal all the way (belt will be all the way to the outside of the bottom pulley). Hold the pedal in this position.
5. Turn the engine off.
6. After engine stops completely, release the clutch-brake pedal.
7. Unscrew the parking brake knob. Remove the transmission cover by removing two truss head screws.
8. Disconnect the speed selector rod from the variable speed pulley by removing the cotter pin and flat washer and lifting rod off the 3/8" pin. See figure 15.

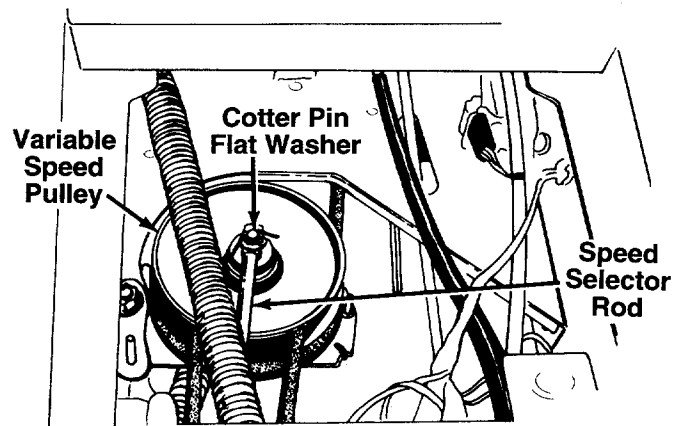

FIGURE 15.

9. Disconnect the speed control link from the variable speed torque bracket by removing the cotter pin and flat washer. See figure 16.

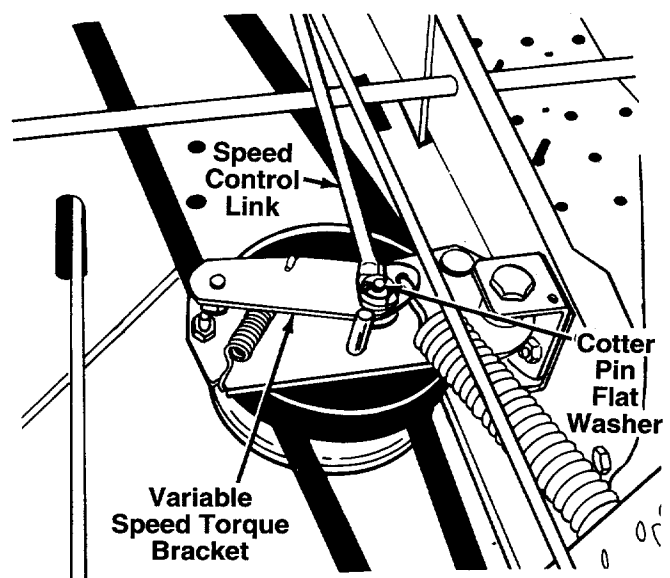

FIGURE 16.—Viewed From Beneath Tractor

10. Place speed control lever in first speed position. Adjust speed selector rod as follows.
  - a. Push rod toward the rear of the tractor, against the end of the slot in the speed control lever assembly.
  - b. Turn rod into or out of the ferrule until it fits freely over the 3/8" pin on the variable speed pulley (turn clockwise to shorten rod, counterclockwise to lengthen rod).
  - c. After rod is adjusted to fit over pin, then turn rod **four (4) full turns counterclockwise**. Move speed control lever to second position. Attach rod to pin on variable speed torque bracket, using the flat washer and cotter pin.
11. Adjust the brake by removing the cotter pin. Tighten the nut by hand until the brake lever locks against the bracket on the transaxle. See figure 17.

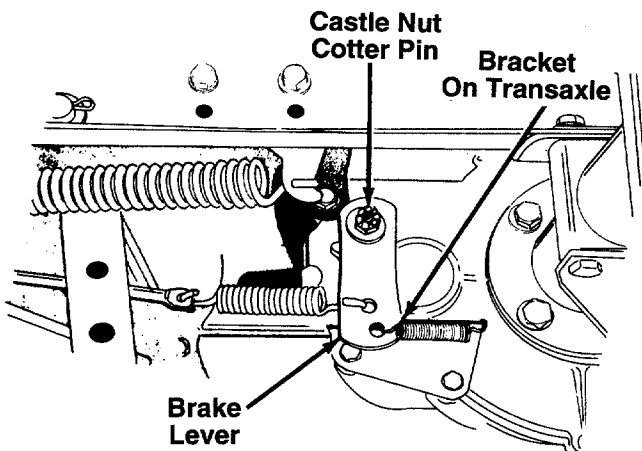

FIGURE 17.

12. Push clutch-brake pedal forward until resistance is felt. Adjust the speed control link in or out until it fits over the pin on the torque bracket. Then shorten **two full turns**. Secure to pin on torque bracket using flat washer and cotter pin.
13. Back the castle nut on the brake off 1 or 2 notches, till the hole in the brake mounting pin aligns with a slot in the castle nut. Secure with cotter pin.

### WHEEL ADJUSTMENT

The caster (forward slant of the king pin) and the camber (tilt of the wheels out at the top) require no adjustment. Automotive steering principles have been used to determine the caster and camber on the tractor. The front wheels should toe-in 1/8 inch.

To adjust the toe-in, follow these steps.

1. Remove the hex nut and lock washer, and drop the tie rod end from the axle bracket. See figure 18.
2. Loosen the hex jam nut on tie rod.
3. Adjust the tie rod assembly for correct toe-in.

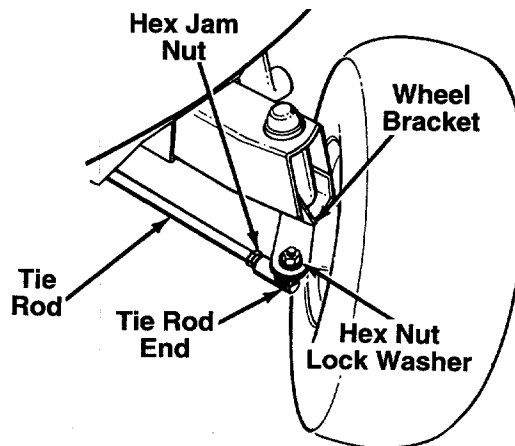

FIGURE 18.

Dimension "B" should be approximately 1/8" less than Dimension "A." See figure 19. To increase Dimension "B," screw tie rod into tie rod end. To decrease Dimension "B," unscrew tie rod from tie rod end. Reassemble tie rod. Check dimensions. Readjust if necessary.

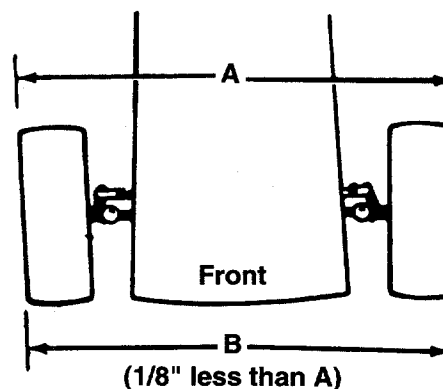

FIGURE 19.

If any further adjustment of the front or rear wheel steering mechanism is needed, the adjustment should be performed by your authorized service dealer.

## CARBURETOR ADJUSTMENT



**WARNING:** If any adjustments are made to the engine while the engine is running (e.g. carburetor), disengage all clutches and blades. Keep clear of all moving parts. Be careful of heated surfaces and muffler.

Minor carburetor adjustment may be required to compensate for differences in fuel, temperature, altitude and load. To adjust the carburetor, refer to the separate engine manual packed with your unit.

**NOTE:** A dirty air cleaner will cause an engine to run rough. Be certain air cleaner is clean and attached to the carburetor before adjusting carburetor.

## BRAKE ADJUSTMENT

During normal operation of this machine, the brake is subject to wear and will require periodic examination and adjustment.



**WARNING:** Do not have the engine running when you adjust the brake.

If brake adjustment is required, refer to step numbers 11, 12 and 13 of the Speed Control Adjustment section.

---

## LUBRICATION

---



**WARNING:** Always stop engine and disconnect spark plug wire before cleaning, lubricating or doing any kind of work on lawn tractor.

### FRONT WHEELS

The front wheels are provided with grease fittings. Lubricate front wheels at least once a season with automotive multi-purpose grease.

### REAR WHEELS AND U-JOINTS

There are grease fittings provided on the rear wheel bearing housings and U-joints. Lubricate every 25 hours of operation using automotive multi-purpose grease. See figure 20. The rear tie rod ends have service-free inserts. **Do not** oil or grease the ball joints.

**NOTE:** Figure 20 is shown with rear wheel removed.

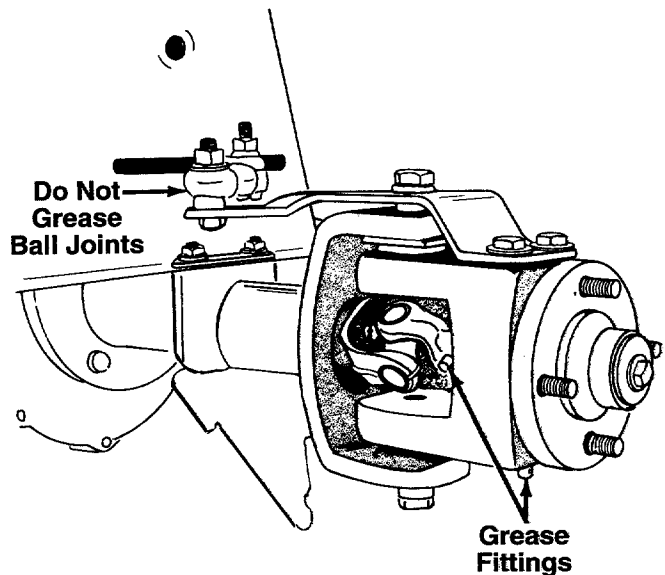

FIGURE 20.

### STEERING GEARS

Lubricate teeth of the external steering gears with automotive multi-purpose grease after every 25 hours of operation or once a season. See figure 21.

The steering box assembly has a grease fitting. However, it should not require lubrication. If disassembled for any reason, lubricate with 4 oz. of #251 E.P. grease, part number 737-3007.

The steering shaft should be lubricated with light oil at least once a season.

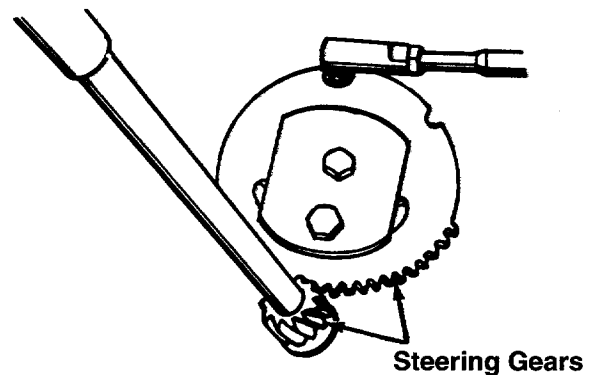

FIGURE 21.

### TRANSAXLE

The transaxle is lubricated at the factory and does not require checking. If disassembled for any reason, lubricate with 32 oz. of Shell grease, part number 737-0148.

### PIVOT POINTS

Lubricate all pivot points with light oil at least once a season.

## MAINTENANCE



**WARNING:** Disconnect the spark plug wire and ground against the engine before performing any repairs or maintenance.

### TROUBLE SHOOTING

Refer to page 17 of this manual for trouble shooting information.

### ENGINE

Refer to the separate engine manual for engine maintenance instructions.

Service **air cleaner** every 10 hours under normal conditions. Clean every few hours under extremely dusty conditions. To service the air cleaner, refer to the separate engine manual packed with your unit.

The **spark plug(s)** should be cleaned and the gap reset once a season. Spark plug replacement is recommended at the start of each mowing season; check engine manual for correct plug type and gap specifications.

Maintain **engine oil** as instructed in the separate engine manual packed with your unit. **Read and follow instructions carefully.**

**NOTE:** On twin cylinder Vanguard engines, the engine is provided with a drain hose for your convenience in draining oil from the crankcase. A clamp secures the drain hose to the side of the engine. See figure 22. To drain the oil, remove the hose from the clamp and remove the drain plug from the end of the hose. Be certain to replace the drain plug and to use the clamp to secure hose to the engine before operating.

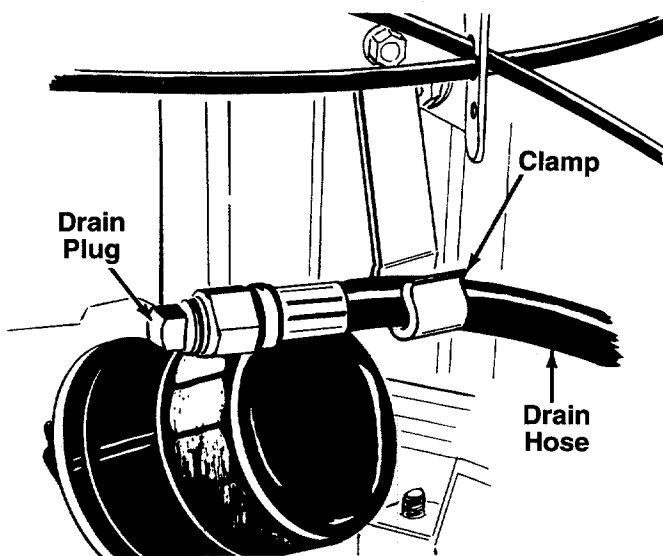

FIGURE 22.—Twin Cylinder Vanguard Engine Only

### CLEANING ENGINE AND DECK

Any fuel or oil spilled on the machine should be wiped off promptly. Grass, leaves, and other dirt must not be left to accumulate around the cooling fins of the engine or on any part of the machine.

Clean the underside of the deck after each mowing.

### CUTTING BLADES

#### A. Removal for Sharpening or Replacement



**WARNING:** Be sure to disconnect and ground the spark plug wire and remove ignition key before working on the cutting blade to prevent accidental engine starting. Protect hands by using heavy gloves or a rag to grasp the cutting blades.

1. Remove the large bolt and lock washer which holds the blade and adapter to the blade spindle.
2. Remove the blade and adapter from the spindle.
3. If the blade or blade adapter needs replacing, remove the two small bolts, lock washers and nuts which hold the blade to the adapter.

#### B. Sharpening

Remove the cutting blades by following the directions of the preceding section.

When sharpening the blades, follow the original angle of grind as a guide. It is **extremely important** that each cutting edge receives an equal amount of grinding to prevent an unbalanced blade. An unbalanced blade will cause excessive vibration when rotating at high speeds, may cause damage to the mower and could break, causing personal injury.

The blade can be tested for balance by balancing it on a round shaft screwdriver. Remove metal from the heavy side until it balances evenly.

**NOTE:** It is recommended that the blade always be removed from the adapter for the best test of balance.

#### C. Reassembly

Before reassembling the blade and the blade adapter to the unit, lubricate the spindle and the inner surface of the blade adapter with light oil. Lubricating the bolt holes, bolts and inner surface of the nuts with light oil is also recommended. A 4 oz. plastic bottle of light oil lubricant is available. Order part number 737-0170. Engine oil may also be used.

When replacing blades, be sure to install the blade with the side of the blade marked "Bottom" (or with part number) facing the ground when the mower is in the operating position.

#### Blade Mounting Torque

Center Bolt: 450 in. lbs. min., 600 in. lbs. max.

Blade Adapter Bolts: 200 in. lbs. min., 350 in. lbs. max.

To insure safe operation of your unit, ALL nuts and bolts must be checked periodically for correct tightness.

## FUEL FILTER

Your unit is equipped with a replaceable in-line fuel filter. Replace filter whenever contamination or discoloration is noticed. Order replacement filter through your engine authorized service dealer.

## BELT REMOVAL AND REPLACEMENT



**WARNING:** Disconnect the spark plug wire and ground it against the engine. Block the wheels of the unit.

**NOTE:** Figures 23, 25 and 26 are shown with the unit tipped up for clarity. It is not necessary to tip the unit to remove the belts.

However, if tipping the unit is desired, remove the battery from the unit. To prevent gasoline leakage, drain the gasoline, or remove the fuel tank cap, place a thin piece of plastic over the neck of the fuel tank and screw on the cap. Be certain to remove the plastic when finished changing the belts. Block unit securely.

### DECK BELT

1. Place the lift lever in the disengaged position.
2. Remove the belt keeper pins from the engine pulley belt guard. See figure 23.

**NOTE:** When reassembling, make certain belt keeper pins are assembled in the same locations from which they were removed.

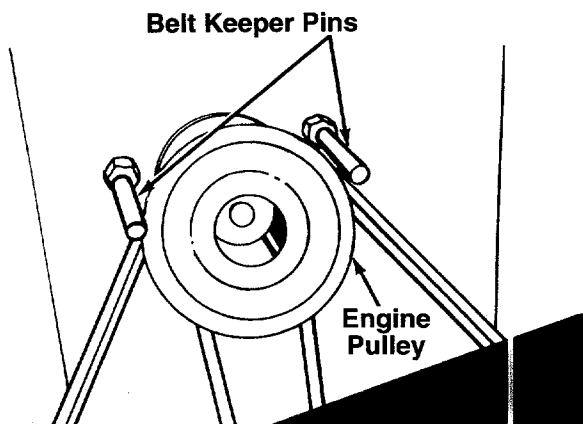

FIGURE 23.

3. Unhook the deck belt from the engine pulley.
4. Place the lift lever in the engaged (all the way forward) position.
5. Disconnect the spring which is attached to a bracket on the transaxle, inside the left rear wheel. Use a spring puller or other suitable tool.
6. Disconnect the six deck links by removing the hairpin clips and flat washers.
7. Disconnect the stabilizer plate from the stabilizer shaft assembly by removing the hairpin clips and flat washers and sliding out the rod. Refer to figure 14.

8. Place the lift lever in the disengaged position.
9. Slide the deck from beneath the lawn tractor.
10. Remove the belt guards at each deck pulley by removing the self-tapping screws. See figure 24.

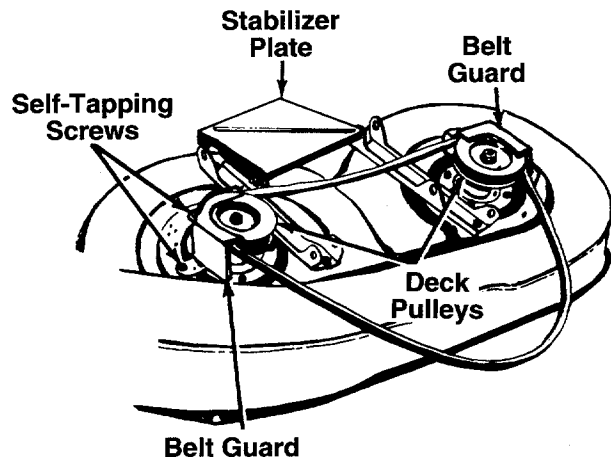

FIGURE 24.

11. Remove and replace the belt, reassemble following the instructions in reverse order.

### REAR DRIVE BELT

1. Unscrew the parking brake knob. Remove the two truss head screws which secure the transmission cover. Remove transmission cover.
2. Disconnect the speed selector rod from the variable speed pulley by removing the cotter pin and flat washer and lifting rod off the 3/8" pin. Refer to figure 15.
3. Push the idler pulley toward the right side of the unit. Lift the belt over the idler pulley.
4. Remove the belt from the variable speed pulley and transmission pulley.
5. Replace belt, and reassemble in reverse order.
6. Adjust the speed control as instructed in adjustment section.

### FRONT DRIVE BELT

1. To remove the front drive belt, first remove the rear drive belt from the idler pulley and variable speed pulley.
2. Place the lift lever in the disengaged position.
3. Remove the belt keeper pins from the engine pulley belt guard. See figure 23.

**NOTE:** When reassembling, make certain hex bolts are assembled in the same locations from which they were removed.

4. Unhook the deck belt from the engine pulley.

- Remove the two self-tapping screws on each side of the frame which hold the engine pulley belt guard to the frame. See figure 25. Remove the engine pulley belt guard by slipping it forward and down.

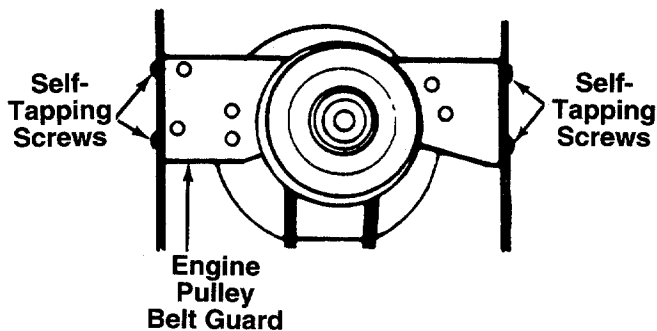

FIGURE 25.

- Place the clutch-brake pedal in park position.
- Push forward on the variable speed pulley, and lift the belt off the engine and remove the belt from the engine pulley.
- Release the clutch-brake pedal. Using the pedal to move the variable speed pulley as necessary, lift the belt up and off the variable speed pulley.

**NOTE:** When reassembling, make certain belt is inside the pins. See figure 26.

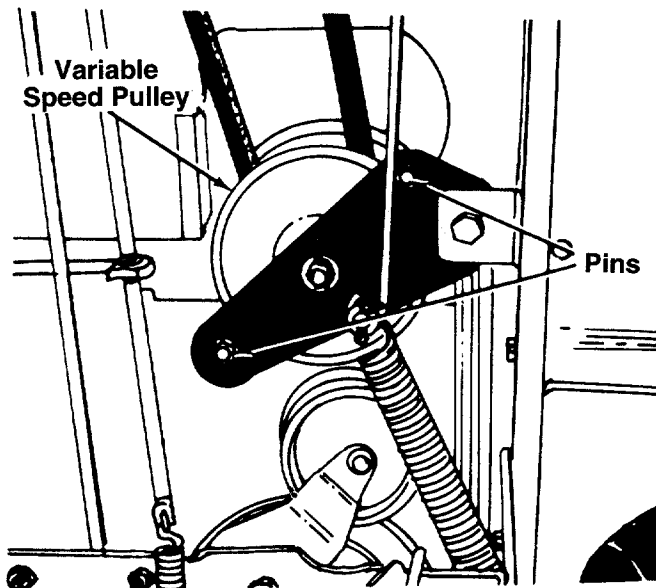

FIGURE 26.

- Reassemble with a new belt, following instructions in reverse order.

- Check the adjustment of the speed control as instructed in the Adjustment section of this manual.
- Adjust the speed control as instructed in Adjustment section.

## BATTERY CARE AND MAINTENANCE

### CHECK FLUID LEVEL

Check fluid level inside each cell of the battery every two weeks and before and after charging. Always keep level between the LOWER LEVEL and UPPER LEVEL lines on battery.

**Add only distilled water. Never add additional acid or any other chemicals to the battery after initial activation.**

**NOTE:** After operating the lawn tractor for a long period of time, check the fluid level in the battery as it can overheat and lose fluid.

### CHARGING THE BATTERY

The engine is equipped with an alternator which charges battery when tractor is operated. Under normal conditions, the battery only needs to be charged before, during and after off-season storage. Follow the instructions under "Off-Season Storage."

**To charge the battery:** Make certain fluid level in each cell is between LOWER LEVEL and UPPER LEVEL. Use a 12 volt automotive charger which is rated less than 10 amps.

Lawn Tractors with Single Cylinder Engines: Charge for 14 to 16 hours. **DO NOT CHARGE LONGER THAN 30 HOURS.**

Lawn Tractors with Twin Cylinder Engines: Charge for a minimum of 3 hours and a maximum of 5 hours.

### REMOVING / INSTALLING / JUMP STARTING



**WARNING:** When removing or installing the battery, follow these instructions to prevent the screwdriver from shorting against the frame.

**Removing the Battery:** Disconnect negative cable first, then positive cable.

**Installing the Battery:** Connect positive cable first, then negative cable.

### Jump Starting

- First, connect end of one jumper cable to the positive terminal of the good battery, then the other end to the positive terminal of the dead battery.
- Connect the other jumper cable to the negative terminal of the good battery, then to the **FRAME OF THE UNIT WITH THE DEAD BATTERY.**



**WARNING:** Failure to use this procedure could cause sparking, and the gas in either battery could explode.

#### **CLEAN THE BATTERY**

Clean the battery by removing it from the unit and washing with a baking soda and water solution. If necessary, scrape the battery terminals with a wire brush to remove deposits. Coat terminals and exposed wiring with grease or petroleum jelly to prevent corrosion.

#### **BATTERY FAILURES**

Some common causes for battery failure are: incorrect initial activation, lack of water, adding chemicals other than water after initial activation, undercharging, overcharging, corroded connections, freezing. **These failures do not constitute warranty.**

#### **TIRES**

Recommended operating tire pressure is approximately 12 p.s.i. (check sidewall of tire for tire manufacturer's recommended pressure). Maximum tire pressure under any circumstances is 30 p.s.i. Equal tire pressure should be maintained on all tires.

When installing a tire to the rim, be certain rim is clean and free of rust. Lubricate both the tire and rim generously. Never inflate to over 30 p.s.i. to seat beads.



**WARNING:** Excessive pressure (over 30 p.s.i.) when seating beads may cause tire/rim assembly to burst with force sufficient to cause serious injury.

---

## **OFF-SEASON STORAGE**

---

If the machine is to be inoperative for a period longer than 30 days, prepare for storage as follows.

1. Clean the engine and the entire unit thoroughly.
2. Lubricate all lubrication points. Wipe the entire machine with an oiled rag to protect the surfaces.
3. Refer to the engine manual for correct engine storage instructions. The engine must be completely drained of fuel to prevent gum deposits from forming on essential carburetor parts, fuel lines and fuel tanks.
4. **Charge battery fully.** The battery loses some of its charge each day when the unit is not used. **NEVER** store battery without a full charge. Recharge battery before returning to service or every two months, whichever occurs first.
5. Store unit in a clean, dry area. Do not store next to corrosive materials, such as fertilizer.

**NOTE:** *When storing any type of power equipment in an unventilated or metal storage shed, care should be taken to rustproof the equipment. Using a light oil or silicone, coat the equipment, especially any chains, springs, bearings and cables.*



# TROUBLE SHOOTING GUIDE

PROBLEM	POSSIBLE CAUSE(S)	CORRECTIVE ACTION
Engine will not crank	Battery installed incorrectly	The battery must be installed with negative terminal attached to black ground wire. Negative terminal is identified at the post by "NEG", "N" or "-". The positive terminal, identified by "POS", "P" or "+", must be attached to the big red wire which goes to the solenoid.
	Battery is dead or weak	Check fluid level in battery. If fluid is low, fill to UPPER LEVEL line with water. Charge with taper charger until fully charged.
	Blown fuse or circuit breaker	Replace fuse with 7-1/2 amp. automotive type fuse. Fuses seldom fail without a reason. The problem must be corrected. Check for loose connections in the fuse holder. Replace fuse holder if necessary. A dead short may be in the cranking or charging circuit where the insulation may have rubbed through and exposed the bare wire. Replace the wire or repair with electrician's tape if the wire strands have not been damaged. Note: Look for a wire pinched between body panels, burned by the exhaust pipe or muffler or rubbed against a moving part.
	Engine ground wire loose	Engine should have a black ground wire running from engine to frame or mounting bolt.
	Safety switch button not depressed	There are two switches in the starting circuit of your unit: the clutch pedal switch and the deck lift lever switch. Make certain the actuator is fully depressing the buttons on each switch.
Engine cranks but will not start	Throttle or choke not in starting position	Check owner's guide for correct position for throttle control and choke for starting.
	No spark to spark plug	Spark plug lead disconnected. Connect lead. Hold spark plug lead away from engine block about 1/8". Crank engine. There should be a spark. If not, have engine repaired at authorized engine service dealer.  Faulty spark plug. To test, remove spark plug. Attach spark plug lead to spark plug. Ground the spark plug body against the engine block. Crank the engine. The spark plug should fire at the electrode. Replace if it does not.
	No fuel to the carburetor	Gasoline tank empty. Fill.  Fuel line or in-line fuel filter plugged. Remove and clean fuel line. Replace filter if necessary.
	Air filter dirty	If the air cleaner is dirty, the engine may not start. Clean or replace as recommended by the engine manufacturer.
Engine smokes	Engine loses crankcase vacuum	Dipstick not seated or broken. Replace defective part. Engine breather defective. Replace.
Excessive vibration	Bent or damaged blade spindle	<b>Stop engine immediately.</b> Check all pulleys, blade adapters, keys and bolts for tightness and damage. Tighten or replace any damaged parts.
	Bent blade	<b>Stop engine immediately.</b> Replace damaged blade. Only use original equipment blades.
Mower will not discharge grass or leaves uncut strips	Engine speed low Speed selection Blades short or dull	Throttle must be set at full throttle. Use lower ground speed. The slower your ground speed, the better the quality of cut. Sharpen or replace blades (uncut strip problem only).

If the above steps fail to correct the problem, take the unit to your local authorized service dealer for repair.

---

## NOTES

---

# SLOPE GAUGE

USE THIS PAGE AS A GUIDE TO DETERMINE SLOPES WHERE YOU MAY NOT OPERATE SAFELY.

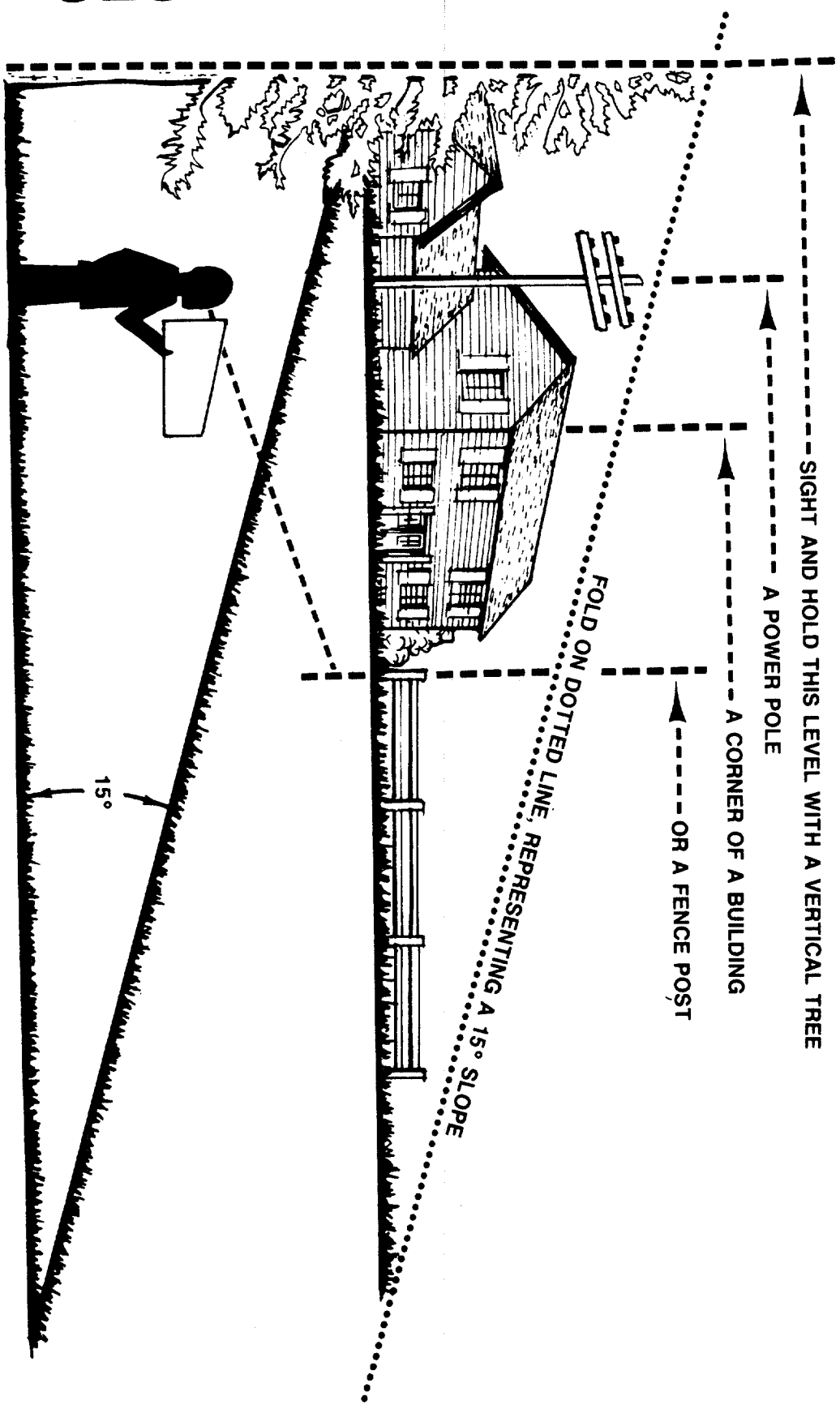

Do not mow on inclines with a slope in excess of 15 degrees (a rise of approximately 2-1/2 feet every 10 feet). A riding mower could overturn and cause serious injury. If operating a walk-behind mower on such a slope, it is extremely difficult to maintain your footing and you could slip, resulting in serious injury.

Operate RIDING mowers up and down slopes, never across the face of slopes.

Operate WALK-BEHIND mowers across the face of slopes, never up and down slopes.



# MANUFACTURER'S LIMITED WARRANTY

## THE MTD TWO YEAR SUPREME WARRANTY:

For **TWO YEARS** from the date of retail purchase within the United States of America, its possessions and territories, MTD PRODUCTS INC will, at its option, repair or replace, for the original purchaser, free of charge, any part or parts found to be defective in material or workmanship. This warranty covers units which have been operated and maintained in accordance with the owner's instructions furnished with the unit, and which have not been subject to misuse, abuse, commercial use, neglect, accident, improper maintenance or alteration. Normal wear parts or components thereof are subject to separate terms as noted below in the "NO FAULT Ninety Day Consumer Warranty" clause.

**NO FAULT Ninety Day Consumer Warranty on Normal Wear Parts:** All normal wear part failures will be covered on this product for a period of 90 days regardless of cause. After 90 days, but within the two year warranty period, normal wear part failures will be covered if caused by defects in material or workmanship of other component parts. Normal wear parts are defined as batteries, belts, blades, blade adapters, grass bags, rider deck wheels, seats and tires.

**How to Obtain Service:** Warranty service is available, with proof of purchase, through your local authorized service dealer or distributor. To locate the dealer or distributor in your area, please check the yellow pages or contact the Customer Service Department of MTD PRODUCTS INC, P.O. Box 368022, Cleveland, Ohio 44136-9722, phone (216) 225-7711. The return of a complete unit will not be accepted by the factory unless prior written permission has been extended by the Service Department of MTD PRODUCTS INC.

**Transportation Charges:** Transportation charges for the movement of any power equipment unit or attachment are the responsibility of the purchaser. Transportation charges for any part submitted for replacement under this warranty must be paid by the purchaser unless such return is requested in writing by MTD PRODUCTS INC.

**Units Exported Out of the United States:** MTD PRODUCTS INC does not extend any warranty for products sold or exported outside of the United States of America, its possessions and territories, except, those sold through MTD's authorized channels of export distribution.

### Other Warranties:

1. The engine or motor or component parts thereof carry separate warranties from their manufacturers. Please refer to the applicable manufacturer's warranty on these items.
2. Log splitter pumps, valves and cylinders or component parts thereof are covered by a one year warranty.
3. All other warranties, express or implied, including any implied warranty of merchantability or fitness for a particular purpose are hereby expressly disclaimed in their entirety.
4. The provisions as set forth in this warranty provide the sole and exclusive remedy of MTD PRODUCTS INC's obligations arising from the sale of its products. MTD PRODUCTS INC will not be liable for incidental or consequential loss or damage.

**How State Law Relates to This Warranty:** This limited warranty gives you specific legal rights, and you may also have other rights which vary from state to state. Certain disclaimers are not allowed in some states and therefore they may not apply to you under all circumstances.

**Note:** This warranty does not cover routine maintenance items such as lubricants, filters, blade sharpening and tune-ups, or adjustments such as brake adjustments, clutch adjustments or deck adjustments. Nor does this warranty cover normal deterioration of the exterior finish due to use or exposure.

