

OWNER'S GUIDE

• ASSEMBLY • OPERATION • MAINTENANCE • PARTS •



22" SELF-PROPELLED ROTARY MOWERS

Model Numbers
123-280B000
123-281C000
123-282C000

IMPORTANT!

Record the **Model No.** and **Mfg. Code** which appear on your unit in the space below. You **must** have these numbers, along with the date of purchase, in order to receive warranty or service.

**Important:
Read Safety Rules
and Instructions Carefully**

MEETS ANSI SAFETY STANDARDS	
MODEL NO.	MFG. CODE
_____	_____



WARNING: This unit is equipped with an internal combustion engine and should not be used on or near any unimproved forest-covered, brush-covered or grass-covered land unless the engine's exhaust system is equipped with a spark arrester meeting applicable local or state laws (if any). If a spark arrester is used, it should be maintained in effective working order by the operator.

In the State of California the above is required by law (Section 4442 of the California Public Resources Code). Other states may have similar laws. Federal laws apply on federal lands. A spark arrester for the muffler is available through your nearest engine authorized service dealer or contact the service department, P.O. Box 368022, Cleveland, Ohio 44136-9722.

IMPORTANT

SAFE OPERATION PRACTICES



THIS SYMBOL POINTS OUT IMPORTANT SAFETY INSTRUCTIONS WHICH, IF NOT FOLLOWED, COULD ENDANGER THE PERSONAL SAFETY AND/OR PROPERTY OF YOURSELF AND OTHERS. READ AND FOLLOW ALL INSTRUCTIONS IN THIS MANUAL BEFORE ATTEMPTING TO OPERATE YOUR LAWN MOWER. FAILURE TO COMPLY WITH THESE INSTRUCTIONS MAY RESULT IN PERSONAL INJURY. WHEN YOU SEE THIS SYMBOL—  **HEED ITS WARNING.**



DANGER: Your lawn mower was built to be operated according to the rules for safe operation in this manual. As with any type of power equipment, carelessness or error on the part of the operator can result in serious injury. If you violate any of these rules, you may cause serious injury to yourself or others.

TRAINING



1. Read this owner's guide carefully in its entirety before attempting to assemble or operate this machine. Be completely familiar with the controls and the proper use of this machine before operating it. Keep this manual in a safe place for future and regular reference and for ordering replacement parts.
2. Your rotary mower is a precision piece of power equipment, not a plaything. Therefore, exercise extreme caution at all times. Your unit has been designed to perform one job: to mow grass. Do not use it for any other purpose.
3. Never allow children under 14 years old to operate a power mower. Children 14 years old and over should only operate mower under close parental supervision. Only persons well acquainted with these rules of safe operation should be allowed to use your mower.
4. Keep the area of operation clear of all persons, particularly small children and pets. Stop engine when they are in the vicinity of your mower to help prevent blade contact or thrown object injury. Although the area of operation should be completely cleared of foreign objects, an object may have been overlooked and could be accidentally thrown by the mower in any direction and cause serious personal injury to the operator or any others allowed in the area.

PREPARATION



1. Thoroughly inspect the area where the equipment is to be used. Remove all stones, sticks, wire, bones and other foreign objects which could be picked up and thrown by the mower in any direction and cause serious personal injury to the operator or any others allowed in the area. Plan your mowing pattern to avoid discharge of material toward roads, sidewalks, bystanders and the like.
2. Always wear safety glasses or eye shields during operation or while performing an adjustment or repair, to protect eyes from foreign objects that may be thrown from the machine in any direction.
3. Wear sturdy, rough-soled work shoes and close-fitting slacks and shirts. Shirts and pants that cover the arms and legs and steel-toed shoes are recommended. Do not wear loose fitting clothes or jewelry. They can be caught in moving parts. Never operate a unit in bare feet, sandals, or sneakers.
4. Before working with gasoline, extinguish all cigarettes, cigars, pipes and other sources of ignition. Check the fuel level before starting the engine. Gasoline is an extremely flammable fuel. Do not fill the gasoline tank indoors, while the engine is running, or until engine has been allowed to cool for at least two minutes after running. Replace gasoline cap securely and wipe off any spilled gasoline before starting the engine as it may cause a fire or explosion.
5. Disengage the self-propelled mechanism or drive clutch on units so equipped before starting the engine.
6. The blade control handle is a safety device. Never attempt to bypass its operation. Doing so makes the safety device inoperative and may result in personal injury through contact with the rotating blade. The blade control handle must operate easily in both directions and automatically return to the disengaged position when released.
7. Never attempt to make a wheel or cutting height adjustment while the engine is running.
8. Never operate the mower in wet grass. Always be sure of your footing. A slip and fall can cause serious personal injury. Keep a firm hold on the handle and walk, never run. Mow only in daylight or in good artificial light.

9. For your safety, use the slope gauge included as part of this manual to measure slopes before operating this unit on a sloped or hilly area. If the slope is greater than 15° as shown on the slope gauge, do not operate this unit on that area or serious injury could result.

OPERATION



1. Do not change the engine governor settings or overspeed the engine. Excessive engine speeds are dangerous.
2. Do not put hands or feet near or under rotating parts. Keep clear of the discharge opening at all times as the rotating blade can cause injury.
3. Stop the blade when crossing gravel drives, walks or roads.
4. After striking a foreign object, stop the engine, remove the wire from the spark plug, and thoroughly inspect the mower for any damage. Repair the damage before restarting and operating the mower.
5. If the equipment should start to vibrate abnormally, stop the engine and check immediately for the cause. Vibration is generally a warning of trouble.
6. Shut the engine off and wait until the blade comes to a complete stop before removing the grass catcher or unclogging the chute. The cutting blade continues to rotate for a few seconds after the engine is shut off. Never place any part of the body in the blade area until you are sure the blade has stopped rotating.
7. Before cleaning, repairing or inspecting, make certain the blade and all moving parts have stopped. Disconnect the spark plug wire, and keep the wire away from the spark plug to prevent accidental starting.
8. Do not run the engine indoors.
9. Never cut grass by pulling mower toward you. Mow across the face of slopes, never up-and-down. Exercise extreme caution when changing direction on slopes. Do not mow excessively steep slopes. Always be sure of your footing. A slip and fall can cause serious personal injury.
10. Never operate mower without proper guards, plates or other safety protective devices in place.
11. Muffler and engine become hot and can cause a burn. Do not touch.



MAINTENANCE AND STORAGE

1. Check the blade and engine mounting bolts at frequent intervals for proper tightness. Also visually inspect blade for damage (e.g. bent, cracked). Replace with blade which meets original equipment specifications.
2. Keep all nuts, bolts, and screws tight to be sure the equipment is in safe working condition.
3. Never store the mower with gasoline in the tank or gas containers inside of a building where fumes may reach an open flame or spark (e.g. gas hot water heater). Allow the engine to cool before storing in any enclosure.
4. To reduce fire hazard, keep the engine free of grass, leaves and excessive oil.
5. Check the grass catcher bag frequently for wear or deterioration. Replace a worn or damaged bag immediately. For safety protection, replace only with new bag meeting original equipment specifications.

SET-UP INSTRUCTIONS

IMPORTANT: This unit is shipped **WITHOUT GASOLINE** or **OIL** in the engine. Be certain to service engine with gasoline and oil before operating your mower.

NOTE: Reference to right or left hand side of the mower is observed from the operating position.

TO REMOVE MOWER FROM CARTON

Remove the carton inserts (if any). Remove the loose parts which are in the carton, lift the mower from the carton, or cut the corners of the carton and roll the mower out.

HOW TO SET-UP YOUR LAWN MOWER

(Refer to Figure 1)

1. Disconnect the spark plug wire and move it away from the spark plug.
2. Remove any cardboard pieces which may be between the upper and lower handles for shipping purposes. If there is any packaging (plastic or cardboard) around the upper handle, remove it.
3. Remove the hairpin clips which are in the weld pins on the handle mounting brackets. Lift the handle assembly from on top of the mower.
4. Attach the handle by placing the bottom holes in the lower handle over the weld pins on the handle mounting brackets. Make certain the lower handle is seated securely into the handle mounting brackets.
5. Pull up on the upper handle to raise it into the operating position. Tighten the hand knobs on each side of the handle.

NOTE: Your mower is shipped with the handle in the higher height position. If you wish to lower the height of the handle, refer to the Adjustment Section at this time.

6. Secure the handle assembly by placing the hairpin clips in the inner hole on weld pins.
7. The rope guide and wing nut are attached to the starter rope, on top of the engine. Remove the wing nut from rope guide. Remove the rope guide from the starter rope.
8. With the spark plug wire disconnected and grounded, hold the blade control handle against the upper handle, and pull the starter rope out of the engine. Hold the rope guide as shown so the opening in the rope guide is toward the front of mower. Slip the rope guide around the starter rope and into the right side of upper handle using the hole shown. Secure using the wing nut.
9. The chute deflector on your mower is held in an upright position by a block for shipping purposes only. To remove the shipping block, move the spring-loaded chute toward the engine by pushing above the shipping block. Remove the block and carefully lower the chute into operating position, keeping fingers out of the way.



WARNING: The shipping block must be removed and discarded before operating the mower.

10. Make certain all nuts and bolts are tightened securely.

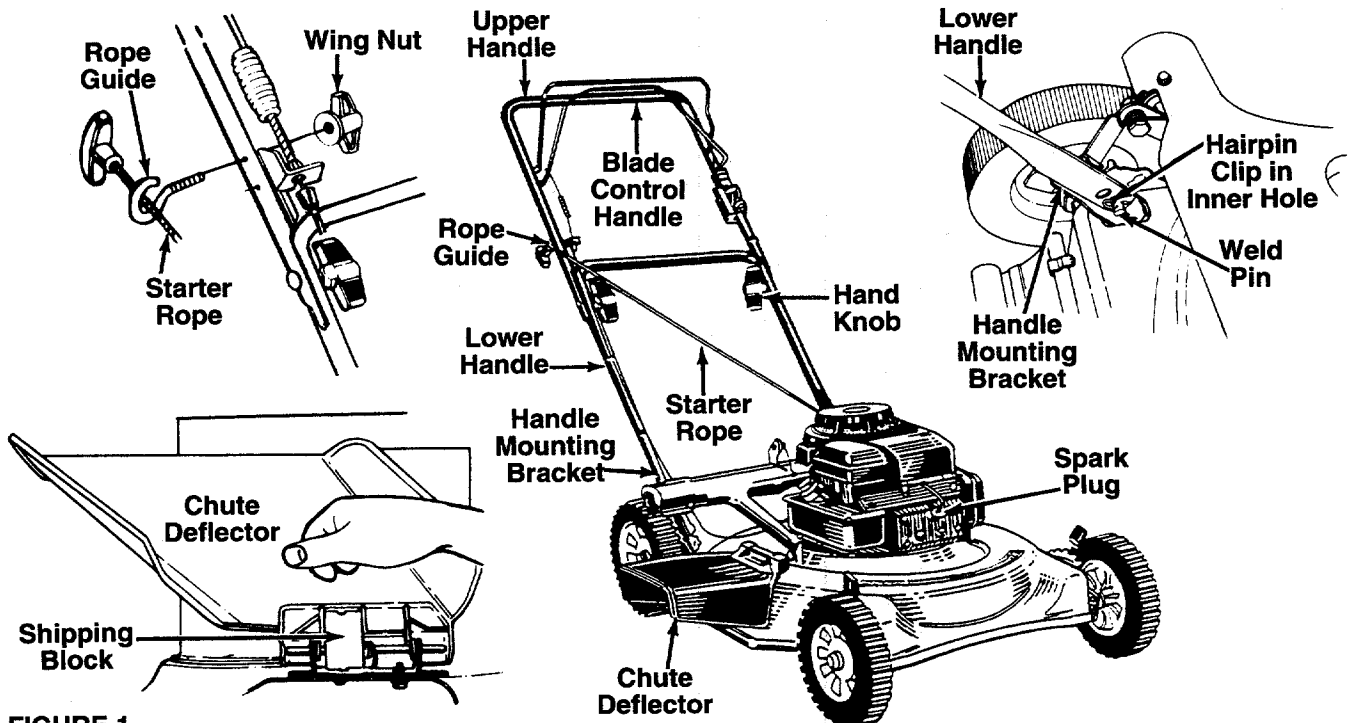

FIGURE 1.

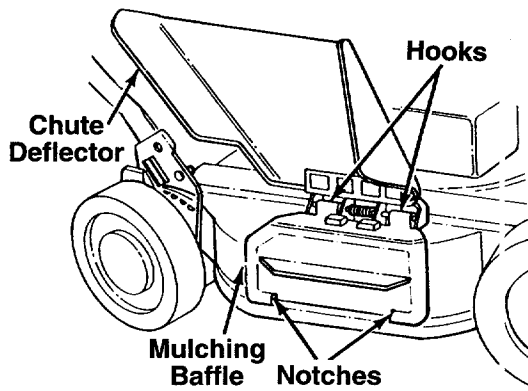

FIGURE 2.

OPTIONAL MULCHING BAFFLE

Mulching kits are available for the mowers shown in this manual. To obtain a mulching kit, order model 190-100.

If your mower is equipped with the optional mulching baffle, install as follows.

1. Lift the chute deflector on the mower. Slide the notches in the bottom of the mulching baffle over the lip of the discharge opening. See figure 2.
2. Push the hooks on the top of the baffle until they snap over the hinge on the discharge chute. Release the chute deflector.

CONTROLS

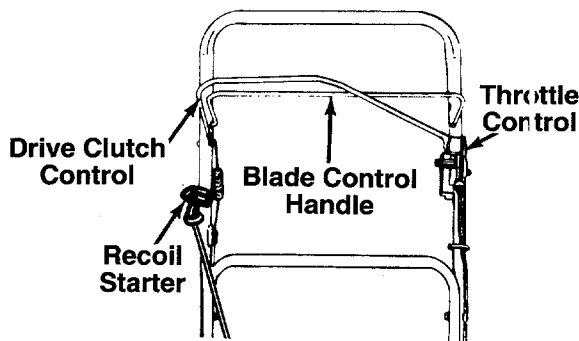

FIGURE 3.

BLADE CONTROL HANDLE



WARNING: This control mechanism is a safety device. Never attempt to bypass its operations.

The blade control handle is located on the upper handle of the mower. See figure 3. The blade control handle must be depressed in order to operate the unit.

Release the blade control handle to stop the engine and blade.



WARNING: The blade will be rotating whenever the engine is running.

THROTTLE CONTROL

The throttle control is located on the side of the upper handle. It is used to regulate the engine speed.



WARNING: The throttle control cannot be used to stop the engine.

RECOIL STARTER

The recoil starter handle is attached to the handle. See figure 3. Stand behind the unit in the operating position to start the unit.

DRIVE CLUTCH CONTROL

Squeezing the drive clutch control engages the drive mechanism to the wheels. Releasing the clutch control stops the wheels from driving. Release the drive clutch control to slow down when negotiating an obstacle, making a turn or stopping. See figure 3.

OPERATION



FIGURE 4.

Keep hands and feet away from the chute area on cutting deck. See figure 4.

The operation of any lawn mower can result in foreign objects being thrown into the eyes, which can result in severe eye damage.



Always wear safety glasses or eye shields. We recommend wide vision safety mask for over spectacles or standard safety glasses.

NOTE: For shipping purposes your mower is set with the wheels in a low cutting height position. For best results raise the cutting position until it is determined which height is best for your lawn. See cutting height adjustment section.

GAS AND OIL FILL-UP

Service the engine with gasoline and oil as instructed in the separate engine manual packed with your mower. **Read instructions carefully.**



WARNING: Never fill fuel tank indoors, with engine running or until the engine has been allowed to cool for at least two minutes after running.

BEFORE STARTING

1. Attach spark plug wire to spark plug. If unit is equipped with a rubber boot over the end of the spark plug wire, make certain the metal loop on the end of the spark plug wire (inside the rubber boot) is fastened securely over the metal tip on the spark plug. See figure 5.

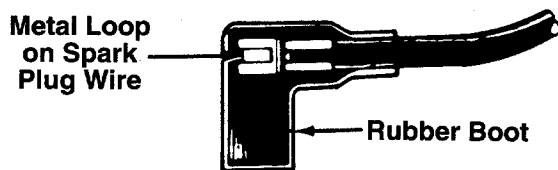

FIGURE 5.

2. Before each use, check drive clutch adjustment. When the clutch handle is engaged, the drive pinions should mesh simultaneously with the gear tread tires. When the clutch handle is released, the pinions should clear the wheels by a minimum of 1/8". See drive clutch adjustment on page 7 for further details.

TO START ENGINE AND ENGAGE BLADE



WARNING: When starting the unit for the first time, face the mower against a solid object such as a wall, fence, etc. Start the unit, and if it shows any signs of motion with the drive clutch control disengaged, shut the engine off immediately.

1. Move throttle control lever all the way forward.
2. If engine is equipped with a primer, prime engine as instructed in the separate engine manual packed with your unit.
3. Standing behind the unit, depress the blade control handle and hold it against the upper handle.
4. Grasp starter handle and pull rope out slowly until engine reaches start of compression cycle (rope will pull slightly harder at this point). Let the rope rewind slowly.

5. Pull rope with a rapid, continuous, full arm stroke. Keep a firm grip on start handle. Return it slowly to the rope guide.
6. After engine starts, move throttle control to desired engine speed.

NOTE: If any problems are encountered, refer to the *Trouble Shooting Guide* on page 9.

TO STOP ENGINE AND BLADE

1. Move throttle control lever to SLOW position.
2. Release the blade control handle to stop the engine and blade.



WARNING: The blade continues to rotate for a few seconds after the engine is shut off.

3. Disconnect the spark plug wire and ground it against the engine to prevent accidental starting while equipment is unattended.

USING YOUR ROTARY MOWER

Be sure that lawn is clear of stones, sticks, wire, or other objects which could damage lawn mower or engine. Such objects could be accidentally thrown by the mower in any direction and cause serious personal injury to the operator and others.

For the best results, do not cut wet grass because it tends to stick to the underside of the mower, preventing proper discharge of grass clippings, and could cause you to slip and fall. New grass, thick grass or wet grass may require a narrower cut. Blade speed should be adjusted to the condition of the lawn.

The best mowing pattern is one that allows the clippings to discharge towards the uncut part of the lawn. This permits recutting of the clippings to further pulverize them. When cutting high weeds, discharge towards cut portion, then recut at right angles to first direction.

For a healthy lawn, never cut more than one-third of the total length of the grass at any one cutting. Lawn should be cut in the fall as long as there is growth.

This mower is designed to be operated at full throttle to give you the best cut and do the most effective job of bagging the cut grass.



WARNING: If you strike a foreign object, stop the engine. Remove wire from spark plug, thoroughly inspect the mower for any damage, and repair the damage before restarting and operating the mower. Extensive vibration of the mower during operation is an indication of damage. The unit should be promptly inspected and repaired.

ADJUSTMENTS



WARNING: Do not at any time make any adjustment to lawn mower without first stopping engine and disconnecting spark plug wire.

CUTTING HEIGHT ADJUSTMENT

An adjusting plate and thumb lever at each wheel position provides cutting height adjustment. Each adjusting plate has nine height positions. Height of cut will be changed when the thumb lever is moved from one position to another. Simply depress the lever towards wheel and move wheel and lever assembly to desired position. All wheels must be placed in the same relative position. See figure 6.

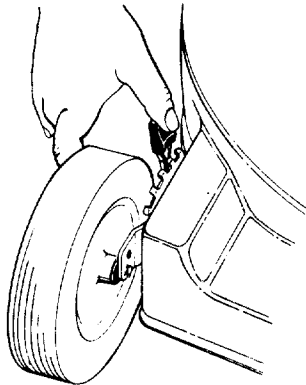

FIGURE 6.

HANDLE HEIGHT ADJUSTMENT

Your mower is shipped with the handle in the higher height position. To lower the handle height, proceed as follows.

1. Remove the starter rope from the rope guide.
2. Remove the upper handle by removing the hand knobs and carriage bolts. Lay the upper handle out of the way, being careful not to bend or kink the cables.
3. Remove the hairpin clips from the weld pins on the handle brackets. Press inward on the legs of the lower handle, and remove it from the mower.
4. Turn the lower handle around so the flat on the bottom is facing upward as shown in figure 7. Reassemble, placing the bottom holes in the handle over the weld pins in the handle mounting bracket.
5. Reassemble the upper handle.
6. Place the hairpin clips in the inner holes in the weld pins and attach the starter rope as instructed in the Set-Up Instructions.

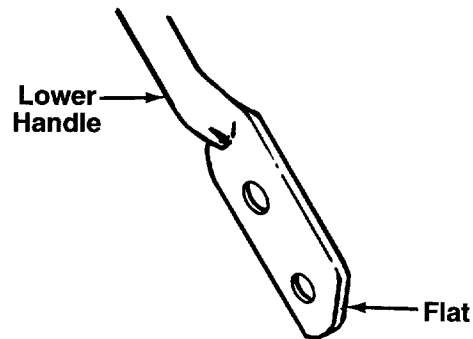

FIGURE 7.

THROTTLE CONTROL ADJUSTMENT

If the throttle control needs adjustment or if it has been replaced, adjust as follows.

1. Remove the screw shown in figure 8. Remove the cable clamp from the cable.

NOTE: If you have a Tecumseh engine, simply loosen the screw shown in figure 8C so the cable will move freely beneath the clamp. It is not necessary to remove the screw and clamp completely.

2. Push the throttle control lever on the handle all the way forward as far as it will go, then back it off one "click." Make certain the throttle control lever remains in this position.
3. Push the control lever on the engine as far toward the rear of the engine as it will go. Secure the cable in this position with the cable clamp and screw.

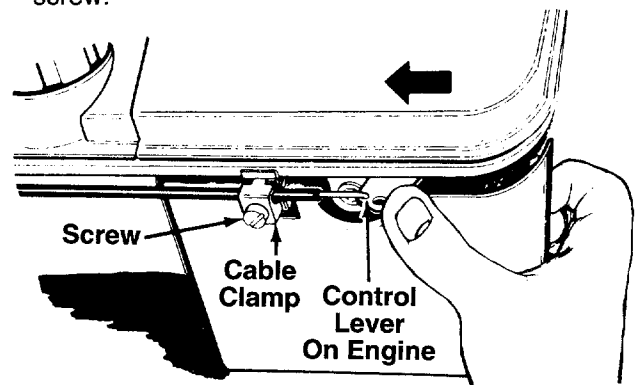

FIGURE 8A.—Quantum Engines

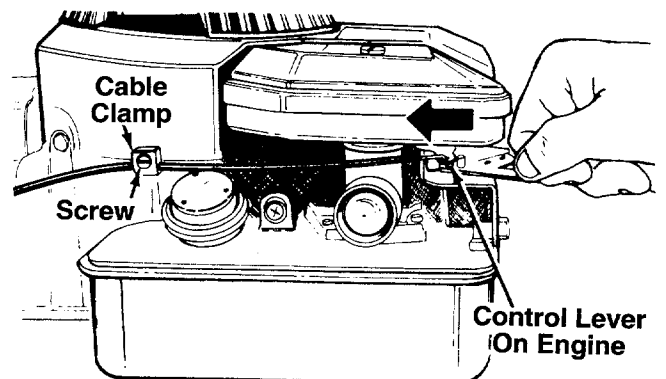

FIGURE 8B.—Sprint and Classic Engines

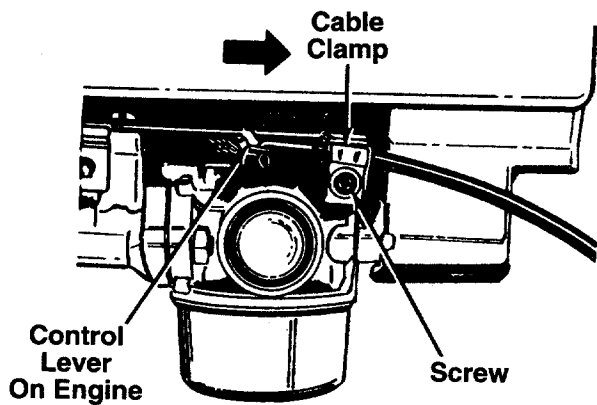

FIGURE 8C.—Tecumseh Engines

DRIVE CLUTCH ADJUSTMENT

The drive pinions should be a minimum of 1/8" from the drive wheels when the clutch is disengaged (clutch control handle is not squeezed against upper handle). See figure 9. When the clutch control is engaged, the drive pinions should mesh with the tires.

If adjustment is necessary, loosen the screw which secures the cable bracket on the handle. See figure 10. Adjust until there is at least 1/8" of clearance. If additional adjustment is required, unhook the cable from the clutch handle, and move it to the higher hole to obtain less clearance. Using the lower hole gives more clearance. Retighten the cable bracket when the correct adjustment is reached.

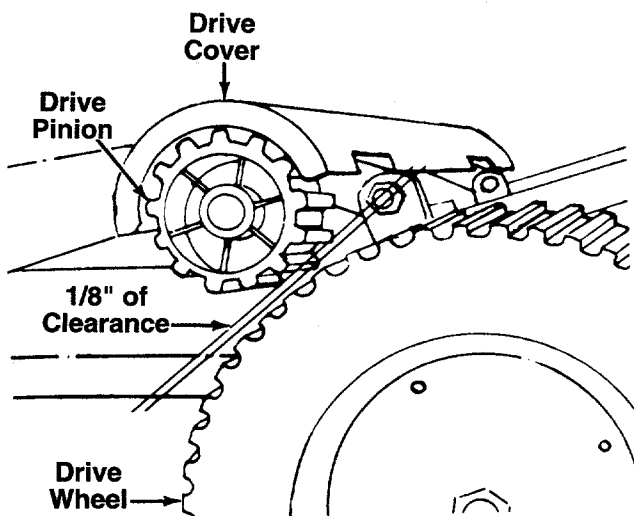

FIGURE 9.

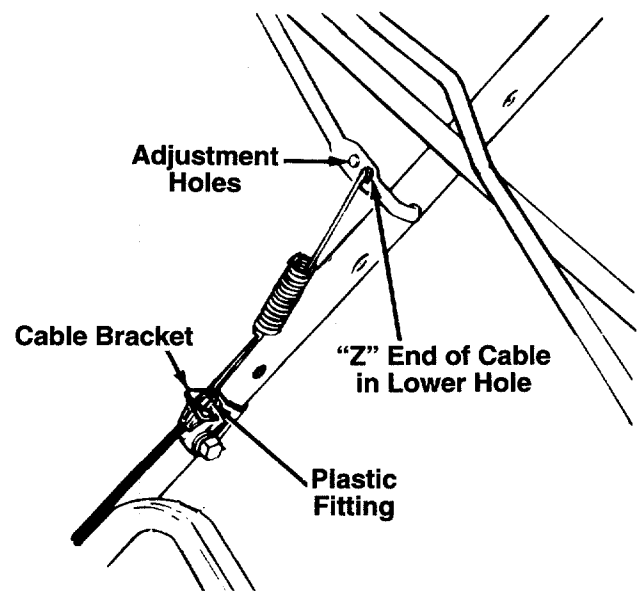

FIGURE 10.

CARBURETOR ADJUSTMENTS



WARNING: If any adjustments are made to the engine while the engine is running (e.g. carburetor), keep clear of all moving parts. Be careful of heated surfaces and muffler.

Minor carburetor adjustments may be required to compensate for differences in fuel, temperature, altitude and load. To adjust carburetor, refer to the separate engine manual packed with your mower.

NOTE: A dirty air cleaner will cause an engine to run rough. Be certain air cleaner is clean and attached to the carburetor before adjusting carburetor.

LUBRICATION



WARNING: Always stop engine and disconnect spark plug wire before cleaning, lubricating or doing any kind of work on lawn mower.

Blade Control—Lubricate the pivot points on the blade control handle and the brake cable at least once a season with light oil. See figure 11. The blade control must operate freely in both directions.

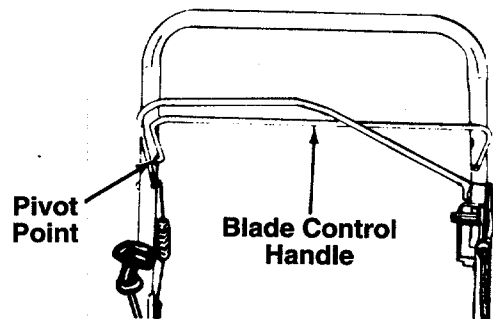

FIGURE 11.

Chute Deflector—The torsion spring and pivot point should be lubricated periodically with light oil to prevent any rust or binding. Deflector must work freely.

Wheels—Mower may be provided with ball bearing wheels. Lubricate at least once a season with light oil. Also, if the wheels are removed for any reason, lubricate the surface of the axle bolt and the inner surface of the wheel with light oil. A 4 oz. plastic bottle of light oil lubricant is available. Order part number 737-0170. Engine oil may also be used.

Engine—Follow engine manual for lubrication instructions.

Chain—The chain should be lubricated periodically with a few drops of light oil to prevent any rust or binding. Use very little or no oil if unit is being used in a dusty or sandy area.

The blade can be tested by balancing it on a round shaft screwdriver. Remove metal from the heavy side until it balances evenly.

Before reassembling the blade and the blade adapter to the unit, lubricate the engine crankshaft and the inner surface of the blade adapter with light oil. Lubricating the bolt holes, bolts and inner surface of the nuts with light oil is also recommended. A 4 oz. plastic bottle of light oil lubricant is available. Order part number 737-0170. Engine oil may also be used.

When replacing the blade, be sure to install the blade with the side of the blade marked "Bottom" (or with part number) facing the ground when the mower is in the operating position.

Blade Mounting Torque

Center Bolt: 450 in. lbs. min., 600 in. lbs. max.

Blade Adapter Bolts: 200 in. lbs. min., 350 in. lbs. max.

To insure safe operation of your unit, **all** nuts and bolts must be checked periodically for correct tightness.

MAINTENANCE



WARNING: Be sure to disconnect and ground the spark plug wire before performing any repairs or maintenance.

NOTE: When tipping the unit, empty the fuel tank and keep engine spark plug side up.

TROUBLE SHOOTING

Refer to page 9 of this manual for trouble shooting information.

CUTTING BLADE

When removing the cutting blade for sharpening or replacement, protect hands by using heavy gloves or a rag to grasp the cutting blade. Remove the bolt and bell washer which hold the blade and adapter to the engine crankshaft. Remove the blade and adapter from the crankshaft.

If the blade or blade adapter needs replacing, remove the two small bolts, lock washers and nuts which hold the blade to the adapter.



WARNING: Periodically inspect the blade adapter for cracks, especially if you strike a foreign object. Replace when necessary.

When sharpening the blade, follow the original angle of grind as a guide. It is extremely important that each cutting edge receives an equal amount of grinding to prevent an unbalanced blade. An unbalanced blade will cause excessive vibration when rotating at high speeds, may cause damage to the mower and could break, causing personal injury.

It is recommended that the blade always be removed from the adapter for the best test of balance.

DECK

The underside of the mower deck should be cleaned after each use to prevent a buildup of grass clippings, leaves, dirt or other matter. If this debris is allowed to accumulate, it will invite rust and corrosion, and may cause an uneven discharge of grass clippings at the next cutting.

The deck may be cleaned by tilting the mower and scraping clean with a suitable tool (make certain the spark plug wire is disconnected).

ENGINE

Refer to the separate engine manual for engine maintenance instructions.

Maintain **engine** oil as instructed in the separate engine manual packed with your unit. Read and follow instructions carefully.

Service **air cleaner** every 25 hours under normal conditions. Clean every few hours under extremely dusty conditions. Poor engine performance and flooding usually indicates that the air cleaner should be serviced. To service the air cleaner, refer to the separate engine manual packed with your unit.

The **spark plug** should be cleaned and the gap reset once a season. Spark plug replacement is recommended at the start of each mowing season; check engine manual for correct plug type and gap specifications.

Clean the engine regularly with a cloth or brush. Keep the cooling system (blower housing area) clean to permit proper air circulation which is essential to engine performance and life. Be certain to remove all grass, dirt and combustible debris from muffler area.

OFF-SEASON STORAGE

The following steps should be taken to prepare lawn mower for storage.

1. Clean and lubricate mower thoroughly as described in the lubrication instructions.
2. Refer to engine manual for correct engine storage instructions.

3. Coat mower's cutting blade with chassis grease to prevent rusting.
4. Store mower in a dry, clean area. Do not store next to corrosive materials, such as fertilizer.

NOTE: When storing any type of power equipment in an unventilated or metal storage shed, care should be taken to rust-proof the equipment. Using a light oil or silicone, coat the equipment, especially cables and all moving parts.

TROUBLE SHOOTING GUIDE

Trouble	Possible Cause(s)	Corrective Action
Engine fails to start	<ol style="list-style-type: none"> 1. Blade control handle disengaged. 2. Spark plug wire disconnected. 3. Throttle control lever not in START position. 4. Fuel tank empty, or stale fuel. 5. Blocked fuel line (if so equipped). 6. Faulty spark plug. 7. Engine flooded. 	<ol style="list-style-type: none"> 1. Engage blade control handle. 2. Connect wire to spark plug. 3. Move throttle lever to START position. 4. Fill tank with clean, fresh gasoline. 5. Clean fuel line. 6. Clean, adjust gap or replace. 7. Remove spark plug, dry the plug, and crank engine with plug removed and throttle in off position. Replace spark plug, connect wire and resume starting procedures.
Engine runs erratic	<ol style="list-style-type: none"> 1. Unit running in START position. 2. Spark plug wire loose. 3. Blocked fuel line (if so equipped) or stale fuel. 4. Vent in gas cap plugged. 5. Water or dirt in fuel system. 6. Dirty air cleaner. 7. Carburetor out of adjustment. 	<ol style="list-style-type: none"> 1. Move throttle lever to FAST position. 2. Connect and tighten spark plug wire. 3. Clean fuel line; fill tank with clean, fresh gasoline. 4. Clear vent. 5. Drain fuel tank. Refill with fresh fuel. 6. Clean air cleaner. † 7. Adjust carburetor. †
Engine overheats	<ol style="list-style-type: none"> 1. Engine oil level low. 2. Air flow restricted. 3. Carburetor not adjusted properly. 	<ol style="list-style-type: none"> 1. Fill crankcase with proper oil. 2. Remove blower housing and clean. † 3. Adjust carburetor. †
Occasional skip (hesitates) at high speed	<ol style="list-style-type: none"> 1. Spark plug gap too close. 2. Carburetor idle mixture adjustment improperly set. 	<ol style="list-style-type: none"> 1. Adjust gap to .030" 2. Adjust carburetor. †
Idles poorly	<ol style="list-style-type: none"> 1. Spark plug fouled, faulty or gap too wide. 2. Carburetor improperly adjusted. 3. Dirty air cleaner. 	<ol style="list-style-type: none"> 1. Reset gap to .030" or replace spark plug. 2. Adjust carburetor. † 3. Clean air cleaner. †
Mower will not drive	<ol style="list-style-type: none"> 1. Drive clutch cable out of adjustment. 2. Wet grass, causing wheels to slip. 	<ol style="list-style-type: none"> 1. Adjust drive clutch cable (see Adjustment section). 2. Do not mow when grass is wet; wait until later to cut.
Excessive vibration	<ol style="list-style-type: none"> 1. Cutting blade loose or unbalanced. 2. Bent cutting blade. 	<ol style="list-style-type: none"> 1. Tighten blade and adapter. Balance blade. 2. Replace blade.
Mower will not discharge grass	<ol style="list-style-type: none"> 1. Engine speed too low. 2. Wet grass. 3. Excessively high grass. 	<ol style="list-style-type: none"> 1. Set throttle between 3/4 and full throttle. 2. Do not mow when grass is wet; wait until later to cut. 3. Mow once at a high cutting height, then mow again at desired height or make a narrower cutting swath (1/2 width).
Uneven cut	<ol style="list-style-type: none"> 1. Wheels not positioned correctly. 2. Dull blade. 	<ol style="list-style-type: none"> 1. Place all four wheels in same height position. 2. Sharpen or replace blade.

†Refer to separate engine manual packed with your unit.

Note: For repairs beyond the minor adjustments listed above, contact your local authorized service dealer.

Models 280, 281 and 282



NOTE

This instruction manual covers various models, and all specifications shown do not necessarily apply to your model. Specifications subject to change without notice or obligation.

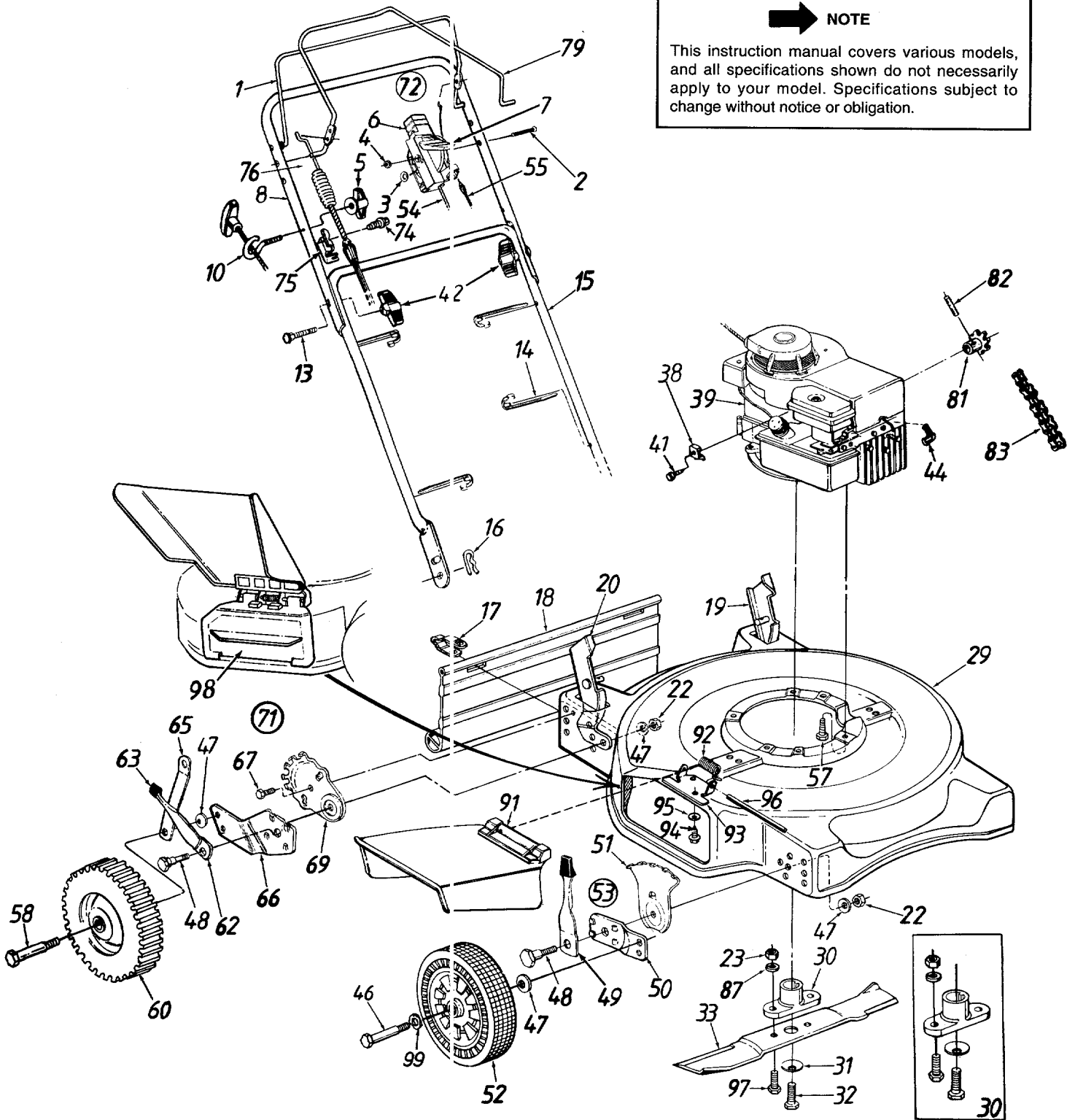

Models 280, 281 and 282

PARTS LIST FOR MODELS 280, 281 AND 282 ROTARY MOWERS

REF. NO.	PART NO.	CODE	DESCRIPTION	REF. NO.	PART NO.	CODE	DESCRIPTION
1	747-0824		Control Handle	54	746-0842		Throttle Control Wire 51" Lg.
2	710-0602		Oval C-Sunk Mach. Scr.	55	746-0550		Control Cable—39"
3	736-0501		Spr. Wash. .66" I.D.	57	710-0654A		Hex L-Wash. Hd. Scr. 3/8-16 x 1.0" Lg.
4	712-0324		Hex L-Nut 1/4-20 Thd.*				
5	712-0397	N	Wing Nut 1/4-20 Thd.	58	738-0144		Rear Axle Bolt
6	746-0875		Throttle Body	60	**		Rear Wheel Ass'y. Comp.
7	746-0876		Throttle Lever	62	732-0417A		Spring Lever
8	749-0538C		Upper Handle	63	720-0190		Spring Lever Knob
10	710-1205		Rope Guide	65	14760A		Link 4.58" Lg.
13	710-1174		Curved Hd. Bolt 5/16-18 x 2" Lg.	66	14765		Pivot Bar R.H.
14	726-0240		Cable Tie		14766		Pivot Bar L.H. (Not Shown)
15	749-0928	N	Lower Handle	67	710-0892		Hex AB-Tap 1/4-.62" Lg.
16	714-0104		Hairpin Cotter	69	14764C		Index Plate
17	17098		Hinge Clip	71	16106		Rear Height Adj. Ass'y.—R.H.
18	731-0872A	N	Rear Flap		16107		Rear Height Adj. Ass'y.—L.H. (Not Shown)
19	17189B	N	Handle Bracket Ass'y.—L.H.				
20	17188B	N	Handle Bracket Ass'y.—R.H.	72	811-00185		Throttle Box Comp. (Incl. Ref. 2, 3, 4, 6, 7)
22	712-0798		Hex Nut 3/8-16 Thd.*				
23	712-0241		Hex Nut 3/8-24 Thd.	74	710-0726		Hex Wash. AB-Tap Scr. 5/16 x .75" Lg.
29	17046		22" Deck Ass'y.				
30	753-0484		Blade Adapter Kit	75	16309A		Cable Brkt.
31	736-0452		Bell-Wash. .39" I.D.	76	746-0629		Clutch Cable
32	710-1044		Hex Bolt 3/8-24 x 1.5" Lg.	79	747-0854		S.P. Bail Ass'y.
33	742-0622	N	22" Blade	81	713-0308		10 Tooth Sprocket Ass'y.
	742-0722	N	22" Mulching Blade (Optional)	82	715-0247		Spring Pin Spir. 3/16" Dia. x 1" Lg.
38	751-0568		Cable Clamp (B&S)				
39	—		Engine	83	713-0311		#48 Chain 1/2" Pitch 50 Links (Endless)
41	710-1237		Hex Wash. Hd. Scr. #10-32 x .62" Lg. (B&S)	87	736-0169		L-Wash. 3/8" I.D.*
42	720-0276	N	Hand Knob	91	731-1034		Chute Deflector Ass'y.
44	735-0639		Spark Plug Boot (Optional)	92	732-0593		Torsion Spring
46	738-0102		Front Axle Bolt	93	17032		Adapter Plate
47	736-0105		Bell-Wash. .400" I.D. x .88"	94	710-0599		Hex Self-Tap Scr. 1/4-20 x .5" Lg.
48	738-0507B		Shld. Bolt .50" Dia. x .357"				
49	14832		Spring Lever Ass'y. w/Knob	95	736-0270		Bell-Wash. 1/4" I.D.
50	15262B		Pivot Bar	96	747-0710		Hinge Pin
51	15261A		Height Adj. Plate	97	710-1055		Hex Bolt 3/8-24 x 1" Lg.
52	**		Front Wheel Ass'y. Comp.	98	731-1386A	N	Mulching Plug (Optional)
53	14578		Height Adj. Ass'y. Comp.—R.H.	99	736-0504		Wave Washer .51" I.D. (Used w/Ball Bearings)
	14579		Height Adj. Ass'y. Comp.—L.H. (Not Shown)				

**WHEEL CHART (8 x 1.75)

Wheels w/o Bearings		Wheels With Bearings		
Tread†	Ass'y. Comp.	Tread†	Ass'y. Comp.	Bearings
Gear	734-1174A			
Bar	734-1608	"T" Tread	734-1566 734-1268	Plastic Brg. 1/2" I.D.-741-0262 (2 per Wheel) Ball Brgs.: 1/2" I.D.-741-0484 (2 per Wheel)
Diamond	734-1780			

†Tread Type: Gear ; Bar ; "T" Tread ; Diamond

Models 280, 281 and 282

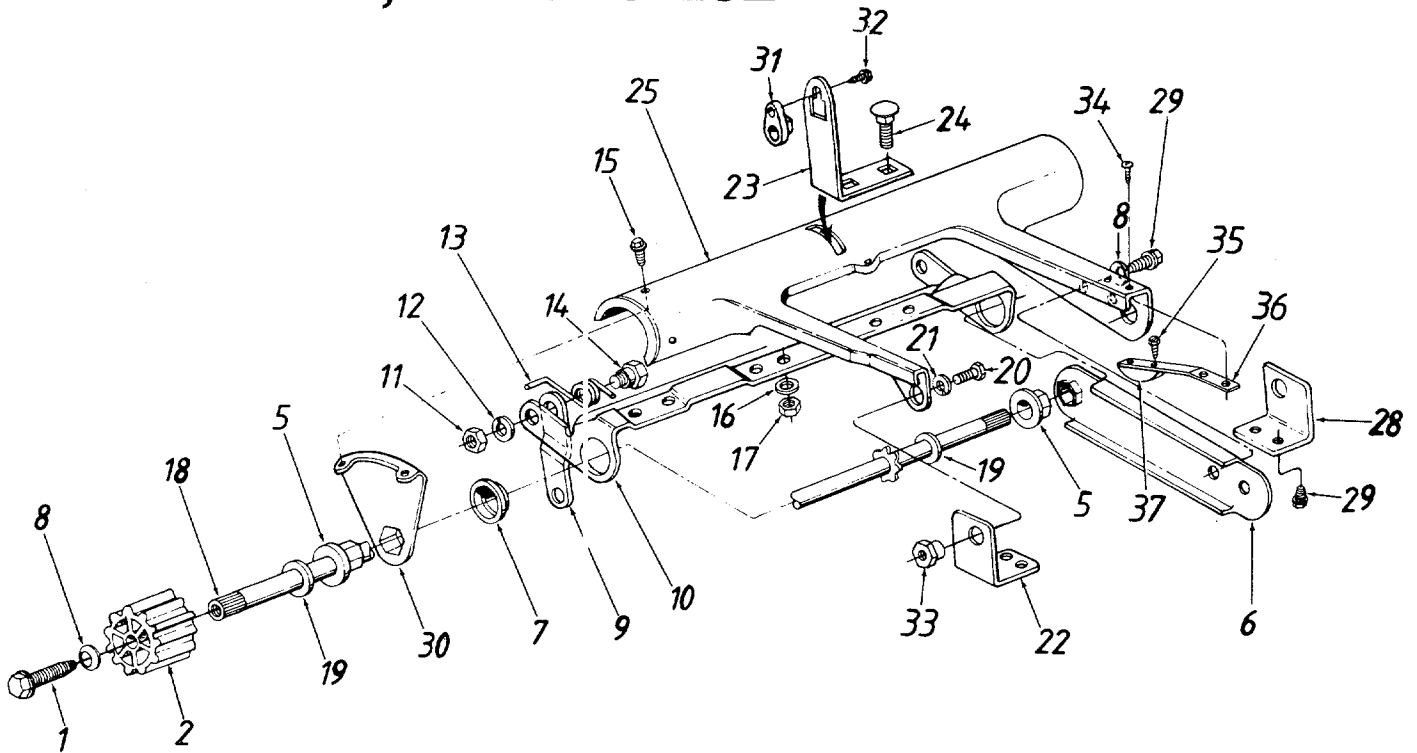

PARTS LIST FOR MODEL 280, 281 AND 282 ROTARY MOWERS

REF. NO.	PART NO.	CODE	DESCRIPTION	REF. NO.	PART NO.	CODE	DESCRIPTION
1	710-1115		Hex Scr. 1/4-20 x .75" Lg. (Gr. 5)	20	710-0168		Hex Bolt 3/8-16 x .5" Lg.*
2	731-0908		Wheel Drive Pinion	21	736-0169		L-Wash. 3/8" I.D.
5	741-0503		Hex Flange Brg. .504" I.D.	22	17614		Pivot Bracket—R.H.
6	17018		Hex Bearing Support	23	16756		Engagement Arm—L.H.
7	741-0504		Flange Bearing .879" I.D.	24	710-0258		Hex Bolt 1/4-20 x .62" Lg.
8	736-0270		Bell-Wash. .265" I.D. x .75" O.D.	25	17726		Rear Pinion Pivot Cover
9	14760A		Link 4.58" Lg.	28	17613		Pivot Bracket—L.H.
10	16832		Drive Engagement Carr	29	710-0892		Hex Wash. Hd. AB-Tap Scr. 1/4 x .62" Lg.
11	712-0267		Hex Nut 5/16-18 Thd.*	30	17017		Hex Bearing Axle Brkt.
12	736-0119		L-Wash. 5/16" I.D.*	31	746-0606		Barrel Cable Hold-Down—R.H.
13	732-0569A	N	Torsion Spring—R.H.	32	710-0919		Hex B-Tap Scr. #10 x .44" Lg.
	732-0570A	N	Torsion Spring—L.H. (Not Shown)	33	738-0529		Shld. Nut .625" Dia. x .165" Lg.
14	738-0754		Shoulder Bolt .437" Dia.	34	710-0351		Truss Mach. B-Tap Scr. #10 x .5" Lg.
15	710-0892		Hex L-Hd. AB-Tap Scr. 1/4" x .62" Lg.	35	710-0429		Hex B-Tap Scr. #10 x 3/8" Lg.
16	736-0329		L-Wash. 1/4" I.D.*	36	732-0634		Cantilever Spring
17	712-0287		Hex Nut 1/4-20 Thd.*	37	731-1136		Chain Tensioner
18	738-0732		Drive Shaft Ass'y. <i>7T</i>				
19	736-0160		FI-Wash. .531" I.D. x .93" O.D.				

*For faster service obtain standard nuts, bolts and washers locally. If these items cannot be obtained locally, order by part number and size as shown on parts list.

PNKTS. USED FOR T.E.C. ENG.

*(22) - 17616 R.H.
(23) 17617 L.H.*

NOTE: The engine is not under warranty by the mower manufacturer. . . If repairs or service is needed on the engine, please contact your nearest authorized engine service outlet. Check the "Yellow Pages" of your telephone book under "Engines-Gasoline."



CODE: N notates a **new part** (not previously existing).

COLOR: A three digit number is the **color code**. Specify color code if color or finish is important when ordering parts. [i.e., (part no.)-638 for Red Finish]

Color Codes

436—Radiant Yellow	638—Red
460—Green Flake	640—Green
483—Charcoal Gray	646—CM Blue
498—Yellow	650—Red Metallic
499—Beige	657—Teal
629—Silver Flake	663—Dark Teal
637—Black	

NOTE: The use of any accessory on this rotary mower other than those manufactured by the mower manufacturer is not recommended. GRASS CATCHER Model 190-086 is available as optional equipment for the mowers shown in this manual.



WARNING: To reduce the risk of injury, do not operate mower unless rear trailing shield and guard or entire grass catcher is in its proper places.

NOTE: Under normal usage bag material is subject to wear and should be checked periodically. Be sure any replacement bag complies with the mower manufacturer's recommendations.

NOTES

USE THIS PAGE AS A GUIDE TO DETERMINE SLOPES WHERE YOU MAY NOT OPERATE SAFELY.

SLOPE GAUGE

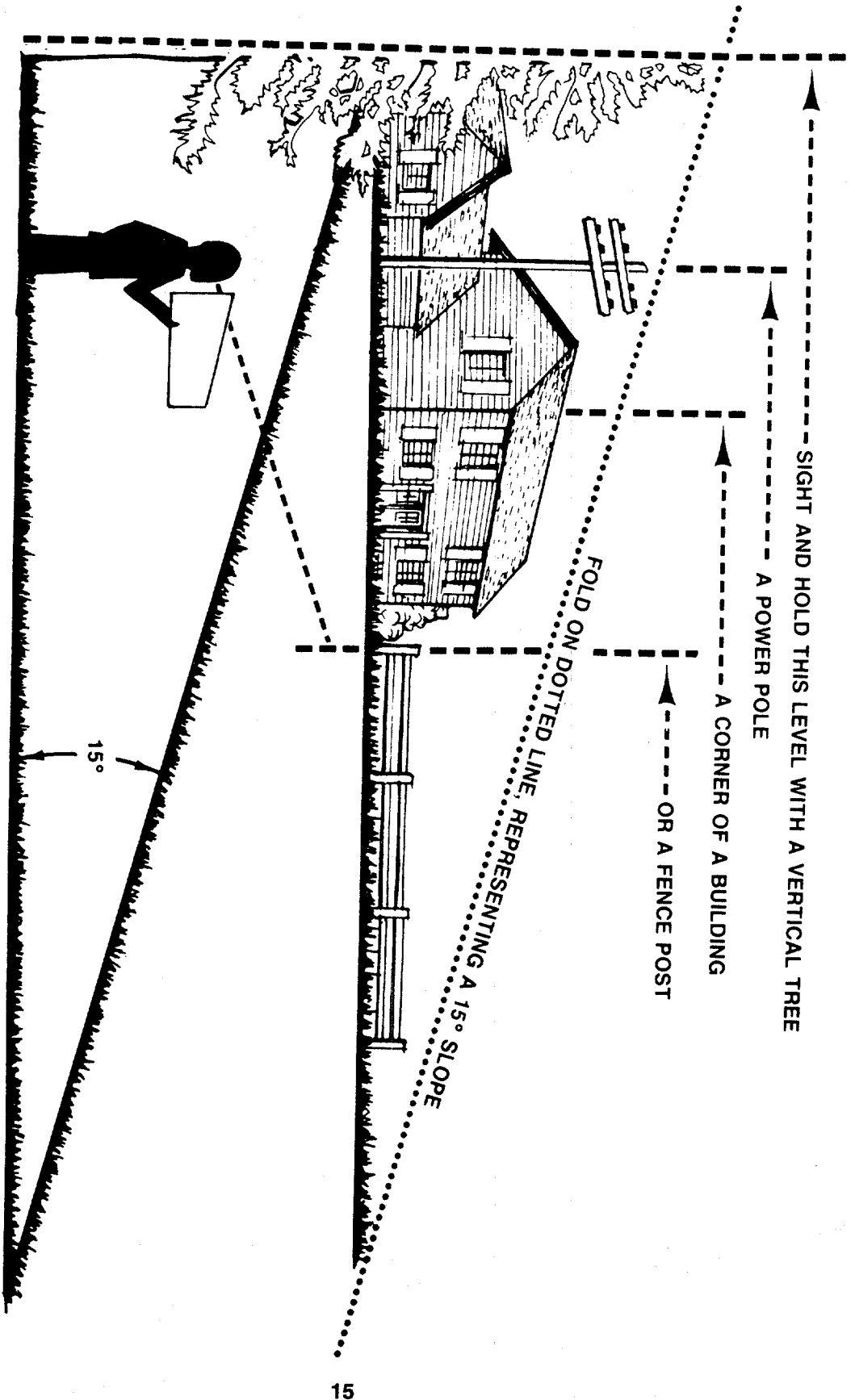

Do not mow on inclines with a slope in excess of 15 degrees (a rise of approximately 2-1/2 feet every 10 feet). A riding mower could overturn and cause serious injury. If operating a walk-behind mower on such a slope, it is extremely difficult to maintain your footing and you could slip, resulting in serious injury.

Operate RIDING mowers up and down slopes, never across the face of slopes.

Operate WALK-BEHIND mowers across the face of slopes, never up and down slopes.



MANUFACTURER'S LIMITED WARRANTY

THE MTD TWO YEAR SUPREME WARRANTY:

For TWO YEARS from the date of retail purchase within the United States of America, its possessions and territories, MTD PRODUCTS INC will, at its option, repair or replace, for the original purchaser, free of charge, any part or parts found to be defective in material or workmanship. This warranty covers units which have been operated and maintained in accordance with the owner's instructions furnished with the unit, and which have not been subject to misuse, abuse, commercial use, neglect, accident, improper maintenance or alteration. Normal wear parts or components thereof are subject to separate terms as noted below in the "NO FAULT Ninety Day Consumer Warranty" clause.

NO FAULT Ninety Day Consumer Warranty on Normal Wear Parts: All normal wear part failures will be covered on this product for a period of 90 days regardless of cause. After 90 days, but within the two year warranty period, normal wear part failures will be covered if caused by defects in material or workmanship of other component parts. Normal wear parts are defined as batteries, belts, blades, blade adapters, grass bags, rider deck wheels, seats and tires.

How to Obtain Service: Warranty service is available, with proof of purchase, through your local authorized service dealer or distributor. To locate the dealer or distributor in your area, please check the yellow pages or contact the Customer Service Department of MTD PRODUCTS INC, P.O. Box 368022, Cleveland, Ohio 44136-9722, phone (216) 225-7711. The return of a complete unit will not be accepted by the factory unless prior written permission has been extended by the Service Department of MTD PRODUCTS INC.

Transportation Charges: Transportation charges for the movement of any power equipment unit or attachment are the responsibility of the purchaser. Transportation charges for any part submitted for replacement under this warranty must be paid by the purchaser unless such return is requested in writing by MTD PRODUCTS INC.

Units Exported Out of the United States: MTD PRODUCTS INC does not extend any warranty for products sold or exported outside of the United States of America, its possessions and territories, except, those sold through MTD's authorized channels of export distribution.

Other Warranties:

1. The engine or motor or component parts thereof carry separate warranties from their manufacturers. Please refer to the applicable manufacturer's warranty on these items.
2. Log splitter pumps, valves and cylinders or component parts thereof are covered by a one year warranty.
3. All other warranties, express or implied, including any implied warranty of merchantability or fitness for a particular purpose are hereby expressly disclaimed in their entirety.
4. The provisions as set forth in this warranty provide the sole and exclusive remedy of MTD PRODUCTS INC's obligations arising from the sale of its products. MTD PRODUCTS INC will not be liable for incidental or consequential loss or damage.

How State Law Relates to This Warranty: This limited warranty gives you specific legal rights, and you may also have other rights which vary from state to state. Certain disclaimers are not allowed in some states and therefore they may not apply to you under all circumstances.

Note: This warranty does not cover routine maintenance items such as lubricants, filters, blade sharpening and tune-ups, or adjustments such as brake adjustments, clutch adjustments or deck adjustments. Nor does this warranty cover normal deterioration of the exterior finish due to use or exposure.

