

HONDA

Power

Equipment

Owner's Manual

COMPACT TRACTOR

H6522

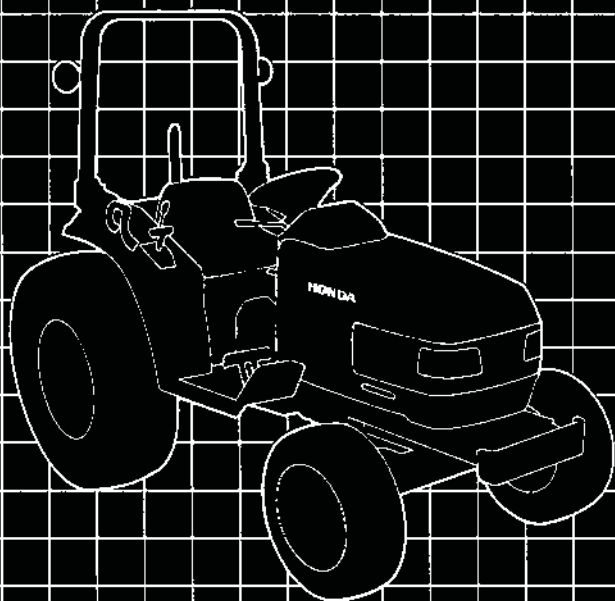

© HONDA MOTOR CO., LTD. 1991

Thank you for purchasing a Honda tractor.

This manual describes operation and maintenance of the Honda H6522 compact tractor, type A2. (Two Wheel Drive Model) and type A4 (Four Wheel Drive Model).

Information in this manual is based on the H6522 A4 model.





All information in this manual is based on the latest product information available at the time of printing.

Honda Motor Co., Ltd. reserves the right to make changes at any time without notice and without incurring any obligation.

No part of this publication may be reproduced without written permission.

This manual is considered a permanent part of the tractor and it must stay with the tractor if resold.

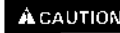
READ THIS OWNER'S MANUAL CAREFULLY. Pay special attention to these symbols and any instructions that follow:

-  **DANGER** — Indicates serious injury or death **WILL** result if instructions are not followed.
-  **WARNING** — Indicates a strong possibility that serious injury or death could result if instructions are not followed.
-  **CAUTION** — Indicates a possibility that minor injury can result if instructions are not followed.
-  **NOTICE** — Indicates that equipment or property damage can result if instructions are not followed.

NOTE: Gives helpful information.

Honda tractors are designed to give safe and dependable service if operated according to instructions. Operating this tractor requires special effort on your part to ensure your safety and the safety of others.

 **WARNING** Using this product for a purpose not intended may cause injury or property damage. Read and understand this Owner's Manual before operating this tractor.

If a problem should arise, or if you have any questions about your tractor, consult an authorized Honda compact tractor dealer.

HONDA MOTOR CO., LTD. 1991, ALL RIGHTS RESERVED

CONTENTS

1. SAFETY INFORMATION	5
2. SERIAL NUMBERS	13
3. COMPONENT IDENTIFICATION	14
4. CONTROLS	16
INSTRUMENT PANEL	16
1. Engine switch	17
2. Fuel gauge	18
3. Coolant temperature gauge	18
4. Tachometer	19
5. Hour meter	19
6. Oil pressure warning light	20
7. Charge system warning light	20
8. Parking brake indicator/warning buzzer	21
9. Headlight switch/indicator	22
10. Flashing warning lights/indicator	22
11. Glow plug indicator	23
12. Storage of Owner's Manual	23
OPERATING CONTROLS	24
1. Throttle lever	24
2. Throttle pedal	25
3. Parking brake lock	25
4. Brake pedal	26
5. Clutch pedal	26
6. Main transmission selector/transmission range selector	27
7. Two- and four-wheel drive select lever (A4 type only)	27
8. Differential lock pedal	28
9. Seat adjusting lever	28
ATTACHMENT OPERATION SYSTEM	29
1. PTO clutch lever	29
2. PTO selector	30
3. Stationary PTO switch/indicator	30
4. Rear PTO shaft/cover	31
5. Lift control lever	31
6. Lift control stop	32
7. Lowering speed control	33
8. Auxiliary hydraulic port	34
5. PRE-OPERATION CHECKS	35
WALK-AROUND CHECKS	35

1. Fuel	36
2. Tires/wheels	38
UNDER-HOOD CHECKS	39
1. Open/close hood	39
2. Side column cover removal	40
3. Engine oil	41
4. Coolant	42
5. Battery	44
6. Fuel filter	45
7. Fan belt	45
8. Power steering belt	46
9. Radiator screen	46
10. Battery under tray	47
OPERATOR-PLATFORM CHECKS	48
1. Steering	48
2. Lights	48
3. Clutch pedal	49
4. Brake pedals	49
5. Parking brake warning buzzer	50
6. Safety interlock system	51
6. OPERATION	54
1. Starting the engine	54
2. Starting/driving	57
3. Warm up and break in operation	61
4. Check hydraulic lift	61
5. Stopping the engine	62
6. Turning	65
7. How to use the differential lock	67
8. Two and four-wheel drive selection (A4 type only)	69
9. Use of power steering	70
10. Attachment limitation	71
11. Operation on a slope	79
12. Uphill starting procedure	80
13. Recommended working speed	81
7. TRANSPORTING	82
8. INSTALLING AN ATTACHMENT	84
1. Rear 3-point hitch link installation (option)	84
2. Rear 3-point hitch attachment installation	86

9. MAINTENANCE	88
1. Tool kit	89
2. Maintenance schedule	90
3. Engine oil change	92
4. Air cleaner service	94
5. Transmission fluid	96
6. Power steering fluid	98
7. Front axle case oil change (A4 type only)	99
8. All fasteners tightness/lubrication points	100
9. Fuel filter	102
10. Radiator core cleaning	103
11. Battery service	104
12. Wheel removal	106
13. Fuse replacement	107
14. Bulb replacement	109
10. LONG TERM STORAGE	110
Storage	110
Removal storage	111
11. TROUBLESHOOTING	112
12. SPECIFICATIONS	115
13. WARRANTY SERVICE	117
14. WIRING DIAGRAM	121

1. SAFETY INFORMATION

WARNING LABEL LOCATION

Read these labels before operating the tractor.

Your Honda compact tractor comes with several labels containing important safety information. Anyone who uses the tractor should read and understand this information before operating the tractor.

The labels should be considered as permanent parts of the tractor. If a label comes off or becomes hard to read, contact an authorized Honda compact tractor dealer for replacements.

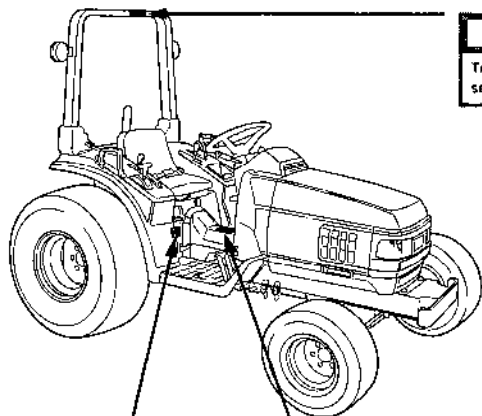

▲WARNING

Tractor operation without the Rollover Protection Structure (ROPS) and seatbelt can result in serious injury. Use ROPS and seatbelt properly.



DIESEL

▲WARNING

Diesel fuel is flammable.
Stop engine. Avoid heat, sparks,
and open flame when refueling.

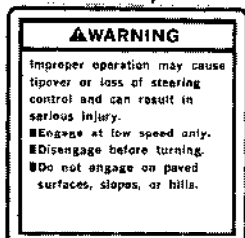

DIFFERENTIAL
LOCK

LOCK

▲WARNING

Tractor can be hazardous if
operated improperly.
To avoid serious injury, read all
safety instructions carefully.

- Read Owner's Manual before
operation.
- Learn the location and function
of all controls.
- Driving too fast, especially with
attachments, can lead to tip
over and serious injury.
- Do not allow children to operate
or play with the tractor or its
controls.
- Contact with attachments or
moving parts can cause serious
injury.

HONDA MOTOR CO., LTD.
MADE IN JAPAN

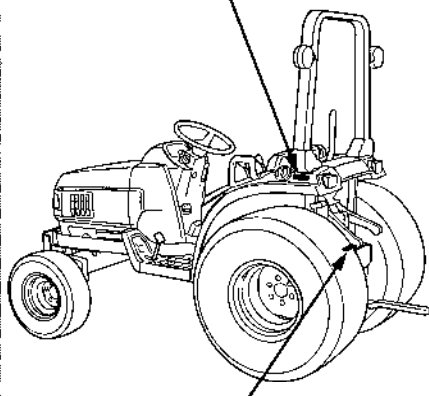

▲WARNING

Contact with the Power
Take-Off (PTO) can cause
serious injury.

- Keep all shields in place.
- Keep hands, feet and
clothing away.

TRACTOR SAFETY INFORMATION

Your Honda Compact Tractor has the power to do an extraordinary amount of work. In the hands of an operator without sufficient skill or knowledge, it has the power to damage property and injure people. It is your responsibility to ensure that any person operating your equipment is aware of safe operating practices and knowledgeable with the contents of this and other related manuals. Regardless of past experience, every operator of your H6522 should read this section carefully before operating the tractor or any equipment attached to it.

1. Before operating the tractor

- (1) Know your equipment and its limitations. Read this entire manual before attempting to start and operate the tractor.
- (2) Pay special attention to the warning and caution labels on the tractor itself.
- (3) We recommend the use of a Roll Over Protective Structures (ROPS) and seat belt in almost all applications. This combination will reduce the risk of serious injury or death should the tractor turn over.

If the ROPS is loosened or removed for any reason, make sure that all parts are reinstalled correctly before operating the tractor. Never modify or repair a ROPS because welding, bending, drilling, grinding, or cutting any portion may weaken the structure.

A damaged ROPS structure must be replaced, not repaired or revised. If any structural member of the ROPS is damaged, replace the entire structure at your local Honda compact tractor dealer.

Install the HIGH-ROPS when the back hoe is used with the tractor as it meets the safety standards established for the back hoe.

- (4) Always use the seat belt if the tractor has a ROPS. Do not use it if there is no ROPS. Check the seat belt daily and replace if frayed or damaged.
- (5) Do not operate tractor or any implement attached to it while fatigued or under the influence of alcohol, medication, or other substances.
- (6) Carefully check the area before operating tractor or any implement attached to it. Check for clearance to all sides and overhead. Do not allow bystanders around or near tractor during operation.

-
- (7) Before allowing other people to use your tractor, explain proper operation to them and have them read this manual. It is your legal obligation to instruct all operators in safe operation.
 - (8) Never wear loose, torn, or bulky clothing around the tractor. They may be caught on moving parts or controls, increasing the risk of an accident. Use additional safety items (hard hat, safety boots or shoes, eye and hearing protection, gloves, etc.) as appropriate or required.
 - (9) Do not allow passengers or non-qualified operators on the tractor at any time. The tractor is designed for only one occupant.
 - (10) Check brakes, clutch, and other mechanical parts for adjustment and wear. Replace worn or damaged parts promptly. Check the tightness of all nuts and bolts regularly. (For further details, see MAINTENANCE AND ADJUSTMENTS.)
 - (11) Keep your tractor clean. Dirt, grease, and trash accumulations contribute to fires and may lead to personal injury.
 - (12) Use only implements meeting the specifications listed under IMPLEMENT LIMITATIONS in this manual. Use the recommended counter weights to maintain the balance of the tractor and reduce the risk of upsets. Follow the safe operating procedures specified in the manuals included with the equipment.
 - (13) The Honda H6522 tractor is not factory equipped with a spark arrester. In some areas, it is illegal to operate an engine without a USDA-qualified spark arrester. Check local laws and regulations before operating. An optional spark arrester is available from an authorized Honda tractor dealer.

2. Operating the tractor

- (1) Never start engine or operate levers from anywhere other than the seat.
- (2) Before, starting the engine, make sure that all levers (including auxiliary control levers) are in their neutral positions, that the parking brake is engaged, and that both the clutch and the Power Take Off (PTO) are disengaged. Fasten the seat belt if the tractor has a ROPS.
- (3) Do not start engine by shorting across starter terminals or bypassing the safety start switch. The machine may start in gear and move if normal starting circuitry is bypassed.

-
- (4) Pull only from the drawbar. Never hitch to axle housing or any other point except drawbar; such arrangements only increase the risk of serious personal injury or death due to a tractor upset.
 - (5) Do not operate or idle engine in a non-ventilated area. Carbon monoxide gas is colorless, odorless, and deadly.
 - (6) Keep all shields and guards in place. Replace any that are missing or damaged.
 - (7) Avoid sudden starts. To avoid upsets, slow down when turning, on uneven terrain, and before stopping.
 - (8) The tractor cannot turn with the differential locked. Attempting to do so could be dangerous.
 - (9) Do not operate near ditches, holes, embankments, or other terrain which may collapse under the tractor's weight. The risk of tractor upset is even higher when the ground is loose or wet.
 - (10) Driving forward out of a ditch or up a steep slope may cause a tractor to tip over backward. Always back out of these situations. Extra caution is required with fourwheel drive models because their higher traction can give you the false confidence in the tractor's ability to climb slopes.
 - (11) To avoid tipping the tractor over, always back up steep slopes. Stay off hills and slopes too steep for safe operation.
 - (12) Watch where you are going at all times. Watch for and avoid obstacles. Be alert at row ends, near trees, and other obstructions.
 - (13) When working in groups, always let the others know what you are going to do before you do it.
 - (14) Never "coast." Disengaging the clutch or shifting into neutral while descending a slope could lead to loss of control.
 - (15) Never try to get on or off a moving tractor.

3. Driving the tractor on the road

- (1) Lock the two brake pedals together to help assure straight-line stops. Uneven braking at road speeds could cause the tractor to roll over.

-
- (2) Always slow the tractor down before turning. Turning at high speed may tip the tractor over.
 - (3) Make sure that the Slow-Moving Vehicle (SMV) emblem is clean and visible. Use slow-moving vehicle warning lights as required.
 - (4) Observe all local traffic and safety regulations.
 - (5) Turn the headlights on. Dim them when meeting another vehicle.
 - (6) Drive at speeds that allow you to maintain control at all times.
 - (7) Do not apply the differential lock while traveling at road speeds. The tractor will not turn correctly and may cause you to lose control.
 - (8) Avoid sudden movement of the steering wheel to avoid a dangerous loss of stability. The risk is especially great when the tractor is traveling at road speeds.
 - (9) Do not operate an implement while the tractor is on the road. Lock it in the raised position.
 - (10) When towing other equipment, use a safety chain in addition to the drawbar hitch and place an SMV emblem on the towed equipment.

4. Stopping the tractor

- (1) Disengage the PTO, lower all implements, place all control levers in their neutral positions, apply parking brake, turn off the engine, and remove the key.
- (2) Make sure that the tractor has come to a complete stop before dismounting.

5. Operating the PTO

- (1) Wait until all moving components have completely stopped before getting off the tractor, connecting, disconnecting, adjusting, cleaning, or servicing any PTO driven equipment.

-
- (2) Keep the PTO shaft cover in place at all times. Replace the PTO shaft cap when the shaft is not in use.
 - (3) Before installing or using PTO driven equipment, read the manufacturer's manual and review the safety labels attached to the equipment.
 - (4) Operate PTO-driven equipment at or below the rated RPM marked on the tachometer.
 - (5) When operating stationary PTO-driven equipment, always apply the tractor parking brake and place chocks behind and in front of the rear wheels. Stay clear of all rotating parts.

6. Using 3-point hitch

- (1) Use the 3-point hitch only with equipment designed for 3-point hitch usage.
- (2) When using a 3-point hitch mounted implement, be sure to install any recommended counter-weight on the front of the tractor.
- (3) When transporting on the road, set the implement lowering control in the "lock" position to hold the implement in the raised position.

7. Servicing the tractor

Before servicing the tractor, park it on a firm level surface, set the parking brake, place the gear shift lever in neutral and stop the engine.

- (1) Allow the tractor time to cool off before working on or near the engine, muffler, radiator, etc.
- (2) Always stop the engine before refueling. Avoid spills and overfilling.
- (3) Do not smoke when working around battery or when refueling. Keep all sparks and flames away from battery and fuel tank. The battery presents an explosion hazard because it gives off hydrogen and oxygen; especially when recharging.
- (4) Before "jumping" a dead battery, read and follow all of the instructions.
- (5) Keep first aid kit and fire extinguisher handy at all times.

-
- (6) Do not remove radiator cap while coolant is hot. Add coolant to the coolant recovery tank, not to the radiator.
 - (7) Disconnect the battery's ground cable before working on or near electric components.
 - (8) To avoid sparks from an accidental short circuit, always disconnect the battery's ground cable first and connect it last.
 - (9) Do not attempt to mount a tire on a rim unless qualified to do so and all proper safety precautions are followed.
 - (10) Provide adequate support when changing wheels.
 - (11) Make sure that wheel bolts have been tightened to the specified torque.
 - (12) Escaping hydraulic fluid under pressure has sufficient force to penetrate skin, causing serious personal injury. Before disconnecting hydraulic lines, be sure to release all residual pressure. Before applying pressure to the hydraulic system, make sure that all connections are tight and that all lines, pipes, and hoses are free of damage. Fluid escaping from pinholes may not be visible. Do not use your bare hands to search for suspected leaks. Use a piece of cardboard or wood, instead. The use of safety goggles or other eye protection is also highly recommended. If injured by escaping fluid, see a medical doctor at once. Fluid can produce severe reactions.

8. Jump starting instructions and precautions

If ice is present or the battery is cracked, do not attempt to "jump start" the vehicle.

- (1) Bring a helper vehicle with a battery of the same voltage as disabled tractor within easy cable reach. **THE VEHICLES MUST NOT TOUCH.**
- (2) Engage the parking brakes of both vehicles and put the shift levers in neutral. Turn off both key switches.
- (3) Put on safety goggles and rubber gloves.
- (4) Remove the vent caps from both batteries.

-
- (5) Cover vent holes with damp rags. Do not allow the rag to touch the battery terminals.
 - (6) Attach the red clamp to the positive (red, (+) or pos.) terminal of the dead battery and clamp the other end of the same cable to the positive (red, (+) or pos.) terminal of the helper battery.
 - (7) Clamp the other cable to the negative (black, (-) or neg.) terminal of the helper battery.
 - (8) Clamp the other end to the engine block or frame of the disabled tractor as far from the dead battery as possible.
 - (9) Start the helper vehicle and let its engine run for a few moments. Start the disabled tractor.
 - (10) Disconnect the jumper cables in the exact reverse order of attachment. (Steps 8, 7 and 6).
 - (11) Remove and discard the damp rags since they may contain sulfuric acid. Reinstall the vent caps.

2. SERIAL NUMBERS

Record the frame and engine serial numbers for your reference. Refer to the serial numbers when ordering parts, and when making technical or warranty inquiries (see page 117).

The frame serial number is stamped on the right side of the frame. The engine serial number is stamped under the muffler (inside the engine compartment).

Frame serial number: _____

Engine serial number: _____

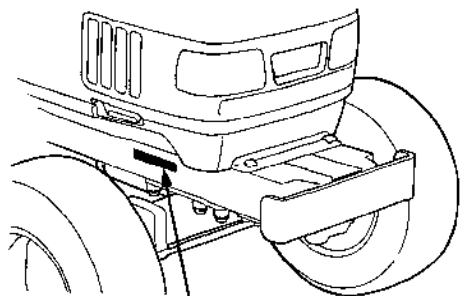

FRAME NUMBER

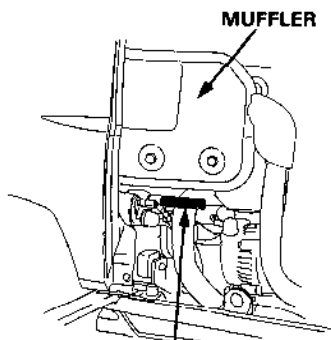

ENGINE NUMBER

3. COMPONENT IDENTIFICATION

ROLLOVER PROTECTIVE STRUCTURE (ROPS)

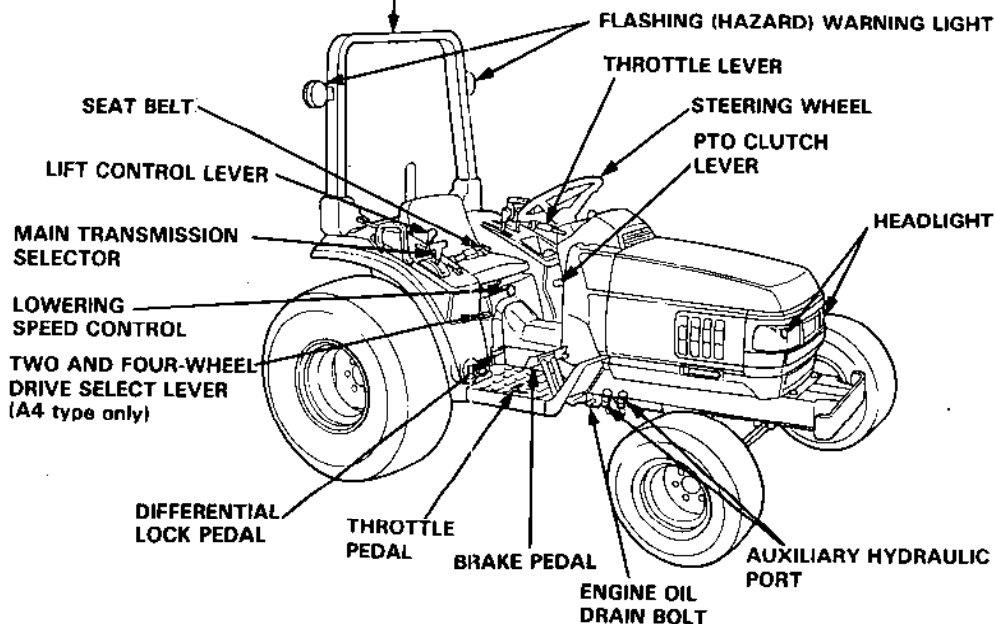

PARKING BRAKE LOCK

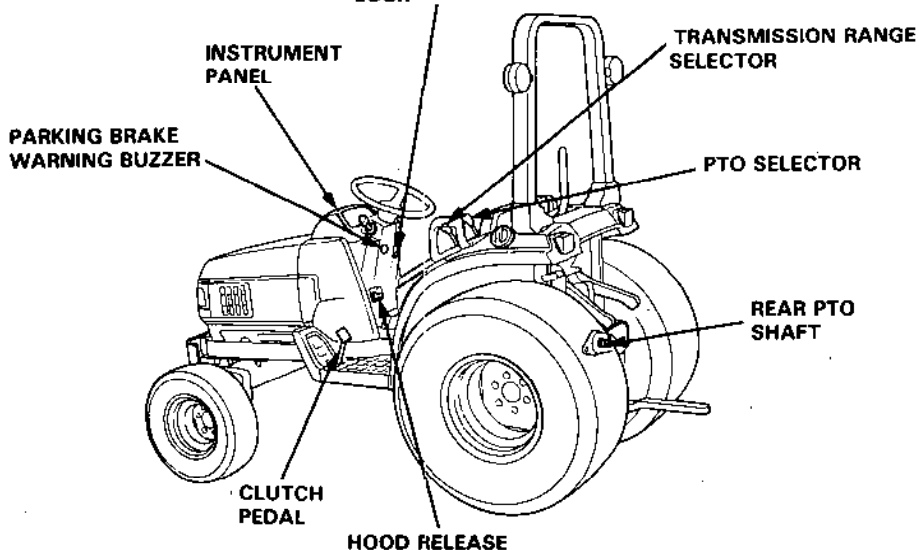

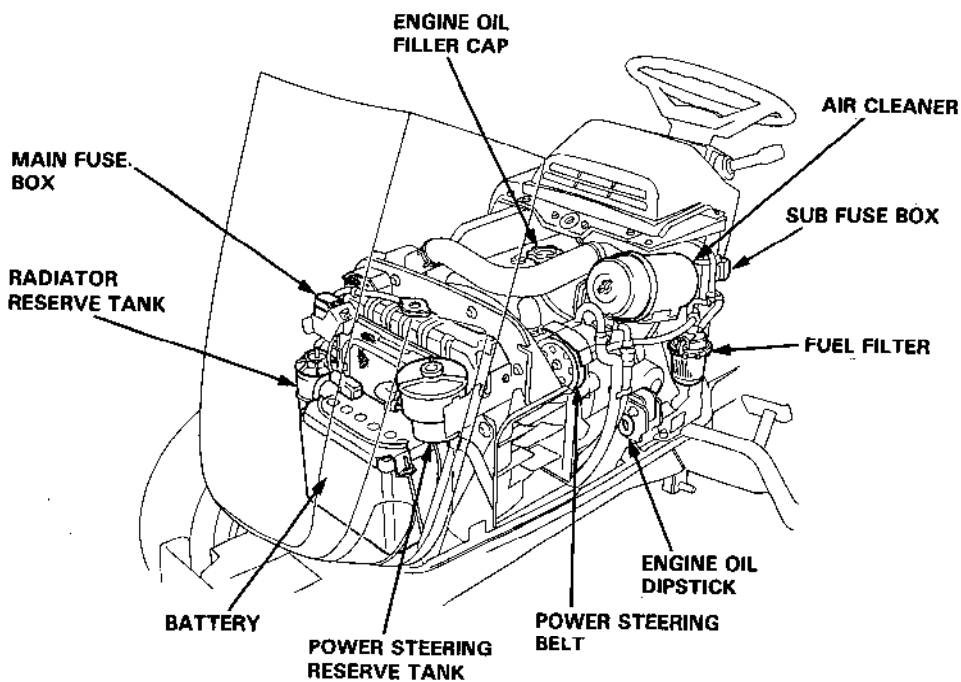
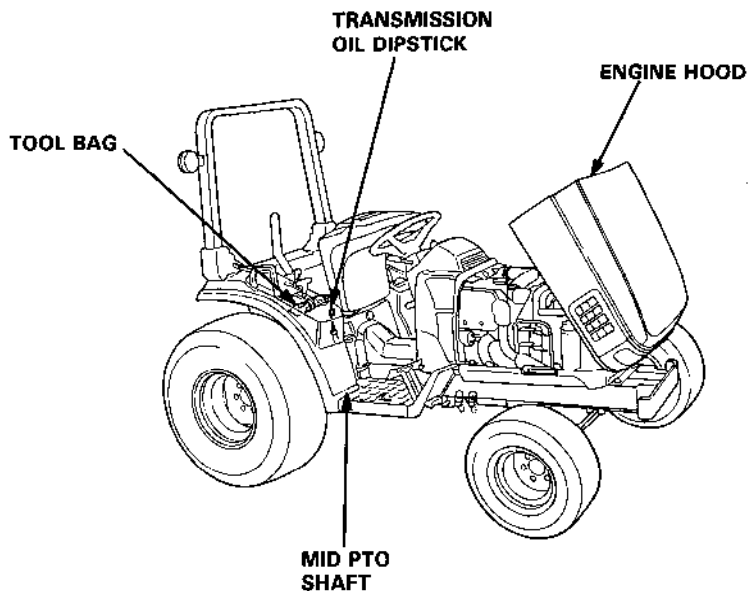

4. CONTROLS

INSTRUMENT PANEL

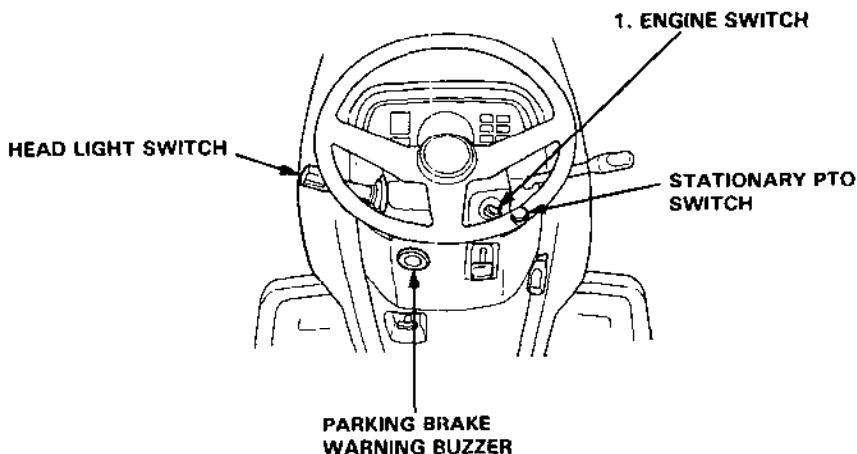
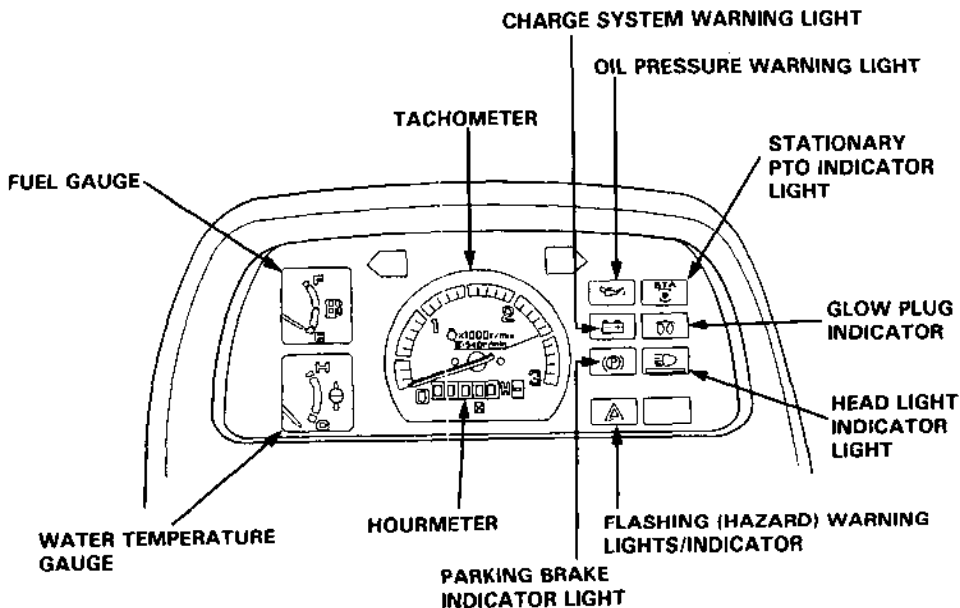

1. Engine switch

⚠ WARNING Always remove the key from the engine switch whenever the tractor is unattended to prevent children or unauthorized persons from starting the engine.

This tractor is equipped with an automotive type ignition switch, which controls all the electrical circuits.

Key positions:

“START” to start the engine. The starter motor turns.

“ON” to run the engine after starting. Electric system is ON.

“OFF” to stop the engine. The engine switch key can be removed.

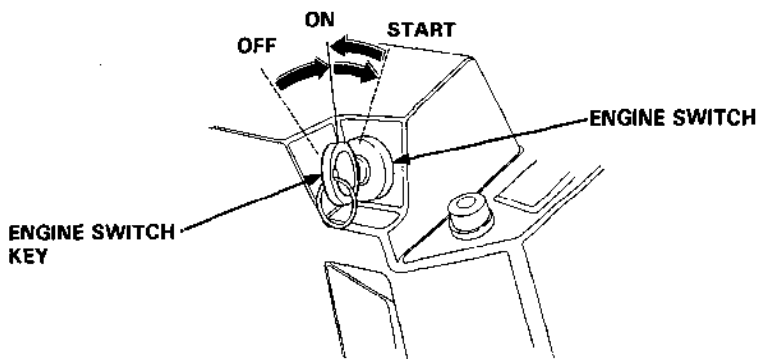

NOTICE Do not leave the engine switch “ON” (key on “ON” position) when the engine is not running as the battery will discharge.

NOTE: The starter will not operate unless the operator is seated in the seat, the main transmission selector is in neutral (N), the PTO clutch is “OFF”, and the brake pedal is depressed or the parking brake set.

2. Fuel gauge

The fuel gauge indicates the amount of fuel in the tank. It operates when the engine switch is in the ON position.

NOTE: When the engine switch is in the OFF position, the fuel gauge will indicate a false fuel level.

When the fuel gauge needle enters under the red zone, it indicates that the amount of remaining fuel in the tank is about 4.5 liters (1.2 gal). Refill as soon as possible.

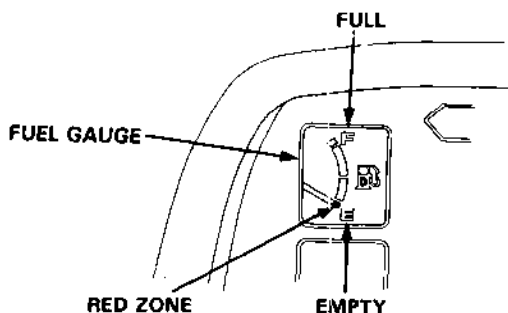

3. Coolant temperature gauge

▲WARNING Do not remove the radiator cap when the engine is hot. The coolant is under pressure and may blow out and scald you.

▲CAUTION The needle should stay within the orange range. If the needle reaches the red line at "H" (Hot), pull to a safe location, stop the engine and check the coolant level in the reserve tank on the right side of the radiator under the hood.

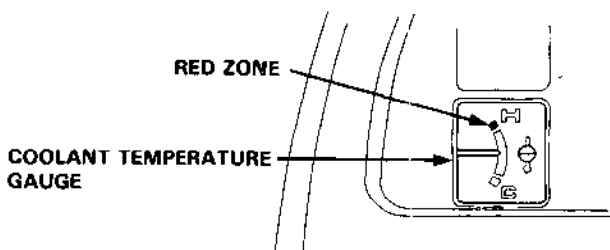

4. Tachometer

Indicates the engine speed in revolutions per minute.

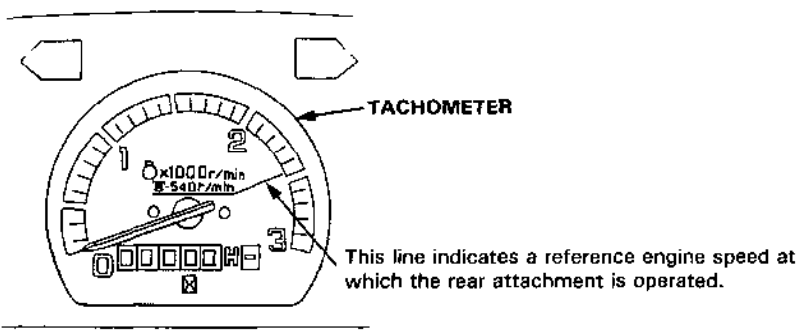

5. Hour meter

Indicates the tractor's total accumulated hours of operation. The number to the right is tenths of an hour. The hour meter will run at actual clock speed only when the engine is running at 2150 RPM.

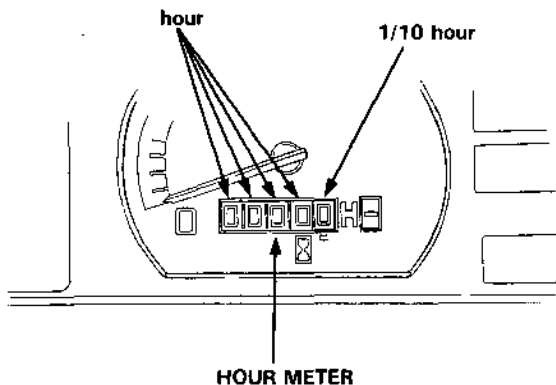

6. Oil pressure warning light

The oil pressure warning light will come on, and remain on, if there is insufficient oil pressure or when the engine switch is turned on with the engine not running.

If the light should stay on while operating the tractor, Pull the tractor to a safe location, turn the engine off, and check the engine oil level (see page 41).

Even if the oil level is correct, the engine should be checked by a Honda compact tractor dealer before the tractor is operated again.

NOTE:

- The oil pressure warning light will only light as a result of low oil pressure. It is not directly an oil level indicator.
- Running the engine while the oil pressure warning light is on constantly may cause immediate and severe engine damage.



7. Charging system warning light

The charging system warning light comes on when there is a problem with the electrical system or when the engine switch is turned on with the engine not running. If the light comes on while operating the tractor, stop the tractor and see if the fan belt is loose or broken. (See page 45 for how to check belt tension.)

⚠ WARNING

If the engine has been running, some engine components may be hot enough to burn you.

If necessary, have the charging system checked by your Honda compact tractor dealer.

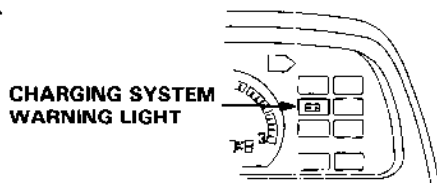

8. Parking brake indicator light/warning buzzer

There is a parking brake indicator light and warning buzzer to remind you to release the parking brake lock before driving the tractor.

When the parking brake is applied, the parking brake indicator goes on. When the transmission selector is set in gear other than "N", the warning buzzer sounds.

NOTICE

- Operating the tractor with the parking brake locked will result in severe damage to the brake lining, and could lead to a complete brake system failure.
- When washing the tractor, do not spray water directly into the warning buzzer to prevent possible damage to the buzzer.

PARKING BRAKE INDICATOR LIGHT

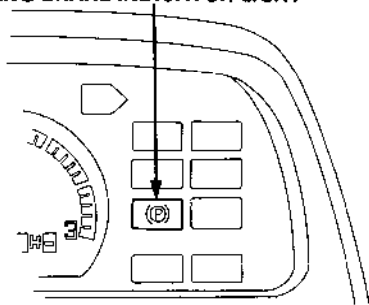

PARKING BRAKE WARNING BUZZER

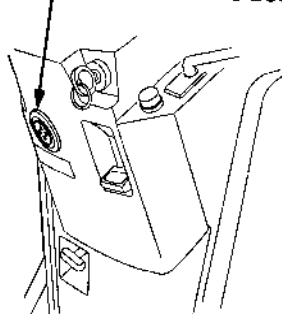

9. Headlight switch/indicator

The headlight switch turns the headlights ON and OFF.

NOTICE Poor visibility increases the risk of striking hidden objects. Reduce speed when operating the tractor in low visibility conditions.

☰—High beam (The headlight, corner light, taillight, and the high beam indicator lights turn on.)

☷—Low beam (The headlight, corner lights and taillight turn on.)

OFF—Headlight is off.

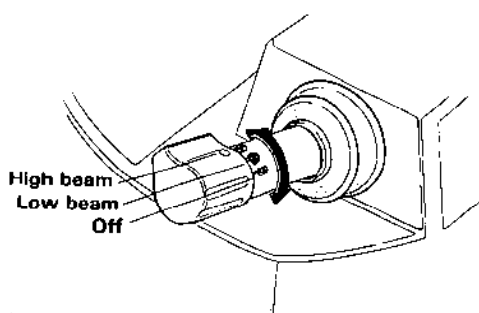
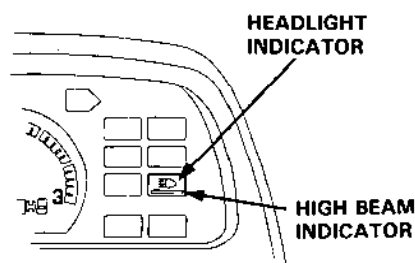

10. Flashing (Hazard) warning lights

Turn the warning lights on by moving the lever forward or backward from its center position. When the lights are on, the indicator on the instrument panel will flash. The warning lights will operate without the engine switch being "ON".

Use the flashing warning lights anytime the tractor is operated on or near a roadway.

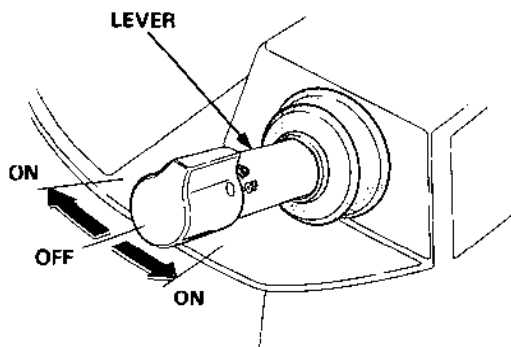
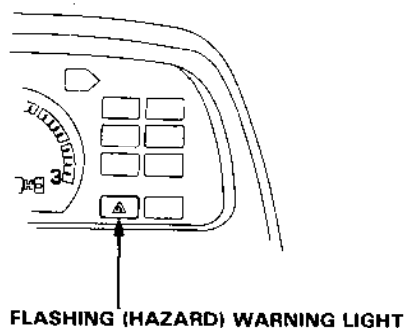

11. Glow plug continuity indicator

The glow plug continuity indicator indicates that the electric current is flowing to the glow plug.

The indicator turns on when the engine switch is turned to the "START" position, and it turns off when the engine switch is turned to the "ON" position.

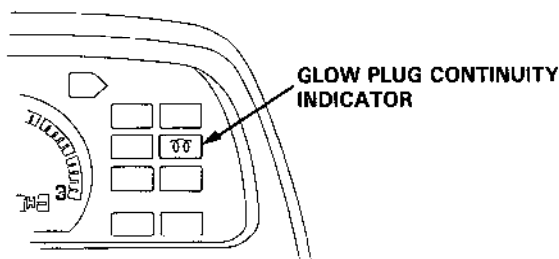

12. Storage of Owner's Manual

Remove the side pocket and store the Owner's Manual in the vinyl bag. Be sure to close the vinyl bag securely.

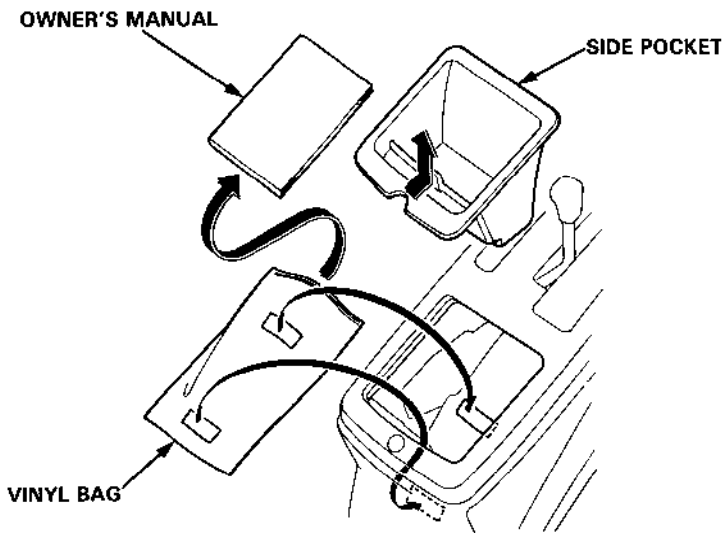

OPERATING CONTROLS

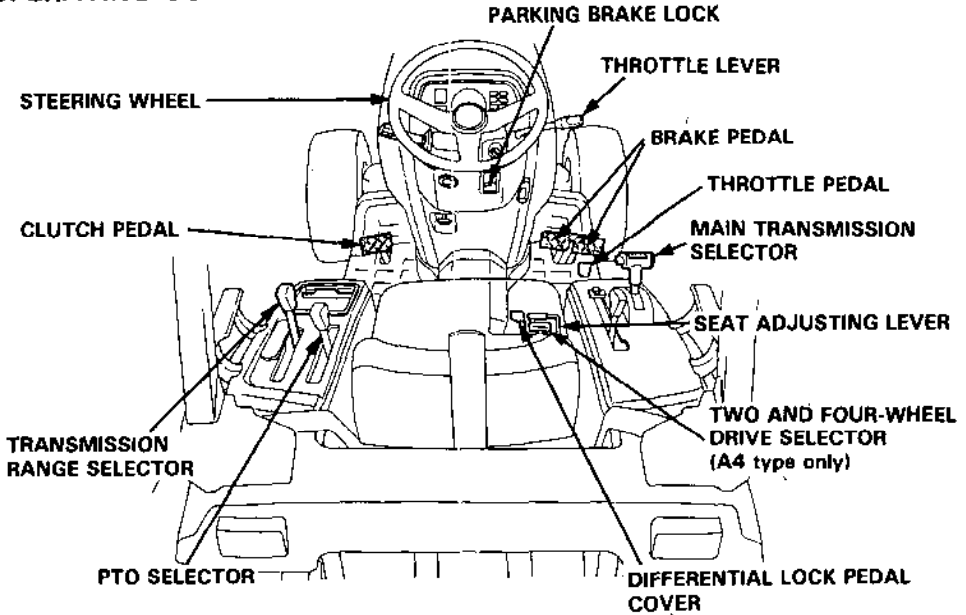

1. Throttle lever

The throttle lever controls engine speed from SLOW (idle) to FAST (max speed); it will stay in any designated position.

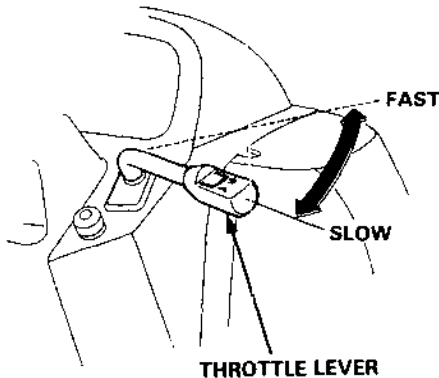

2. Throttle pedal

The throttle pedal should be used with the throttle lever set in SLOW (idle) position. Depress the pedal to increase the engine speed. Releasing the foot from the pedal causes the engine speed to decrease. Use this pedal when operating on roads or transporting your tractor from one place to another.

CAUTION The minimum speed of the engine is determined by the position of the throttle lever. When the throttle lever is set in FAST position, the engine speed is not lowered to the idle speed when the pedal is released and can cause accident or injury.

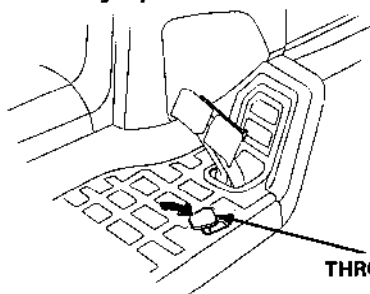

3. Parking brake lock

Set the parking brake whenever the tractor is stopped.

1. Be sure the brake pedals are interconnected with the connector plate (see page 26).
2. Firmly depress and hold the brake pedals.
3. Push down and hold the parking brake lock.
4. Release the brake pedals and then release pressure on the parking brake lock.

To release the parking brake, push on the brake pedals until the parking brake lock moves to its "OFF" position.

NOTICE Operating the tractor with the parking brake locked will result in severe damage to the brake lining, and could lead to a complete brake system failure.

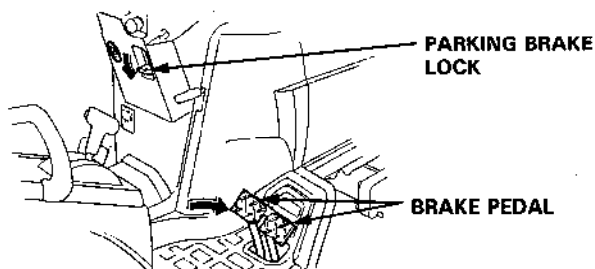

4. Brake pedal

The brake pedals operate the brakes on the rear wheels of the tractor. The left and right brakes can be applied independently by disconnecting the pedals with the connector plate. For normal operation, keep the pedals interconnected.

NOTICE

- Depressing the brake pedal hard while the tractor is being driven may cause damage to the tractor drive components unless the clutch pedal is depressed first.
- Driving the tractor with the brake pedal partly depressed can damage the brake lining.

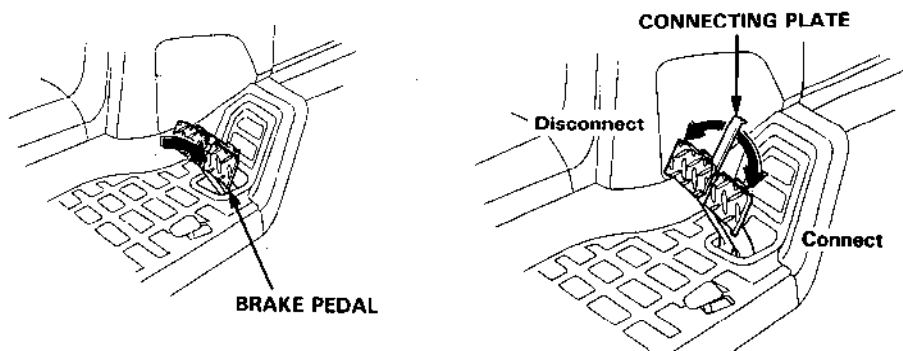

5. Clutch pedal

Depress the clutch pedal to disconnect engine power from the transmission. Always depress the clutch pedal before moving the transmission range selector.

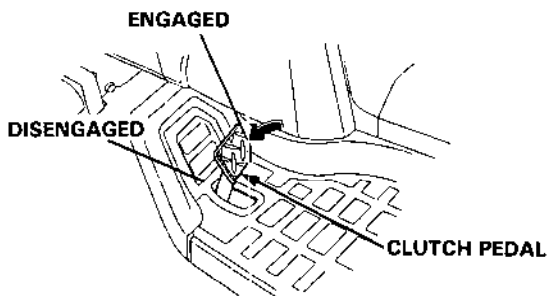

6. Main transmission selector/transmission range selector

Nine forward speeds and three reverse speeds are available by using the main transmission selector and the transmission range selector (see SPECIFICATIONS, page 115).

The main transmission selector can be shifted between forward speeds while driving without using the clutch. To prevent abrupt starts when the transmission range selector is in "3" range, always use the clutch to start the tractor or shift speeds.

Always come to a full stop before shifting between reverse and forward speeds.

Always come to a full stop and depress the clutch before moving the transmission range selector.

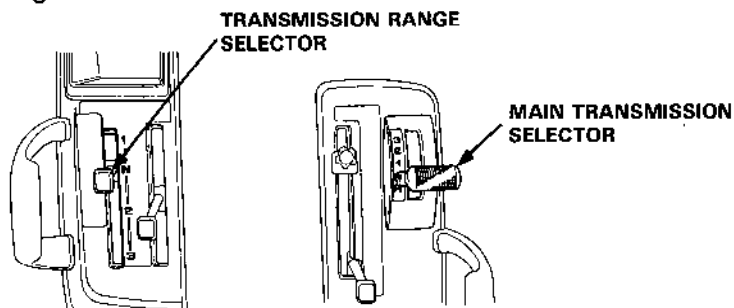

7. Two-and four wheel drive selector (A4 type only)

Two and four wheel drive can be selected by operating this lever. To shift into four wheel drive, move the selector up to the four wheel drive position. For two wheel drive, move the select lever down to the two wheel drive position.

NOTICE Before moving the selector, be sure to bring the tractor to a complete stop and depress the clutch pedal fully.

For operation of the two-and four-wheel drive select lever, refer to page 69.

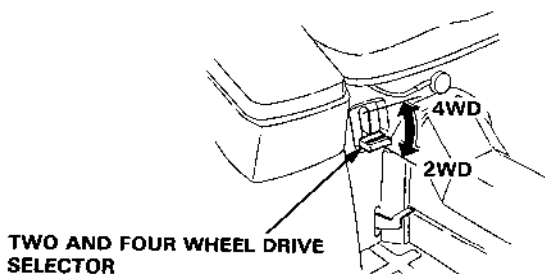

8. Differential lock pedal

When greater straight-line traction is needed on loose or soft terrain, pushing and holding the pedal locks the differential, causing both rear wheels to rotate at the same speed. For normal operation, the pedal should be released (unlocked) so that the differential allows one rear wheel to rotate at a different speed than the other around curves.

To release the lock remove your foot from the pedal. For operation of the differential lock, refer to Page 67.

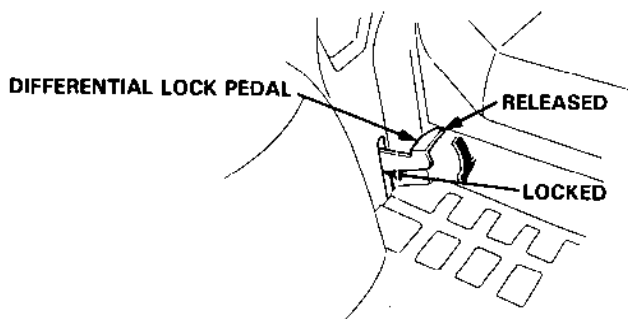

9. Seat adjusting lever

Raise the adjusting lever under the seat to adjust the seat position. After adjustment, be sure that the seat is securely locked in position .

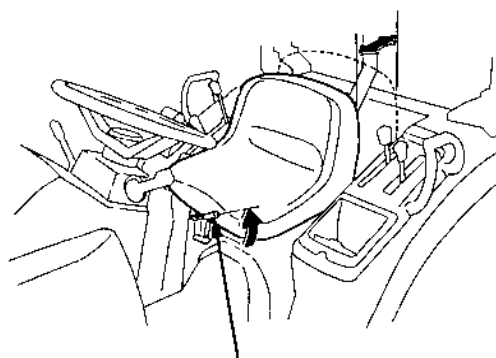

SEAT ADJUSTING LEVER

ATTACHMENT OPERATION SYSTEM

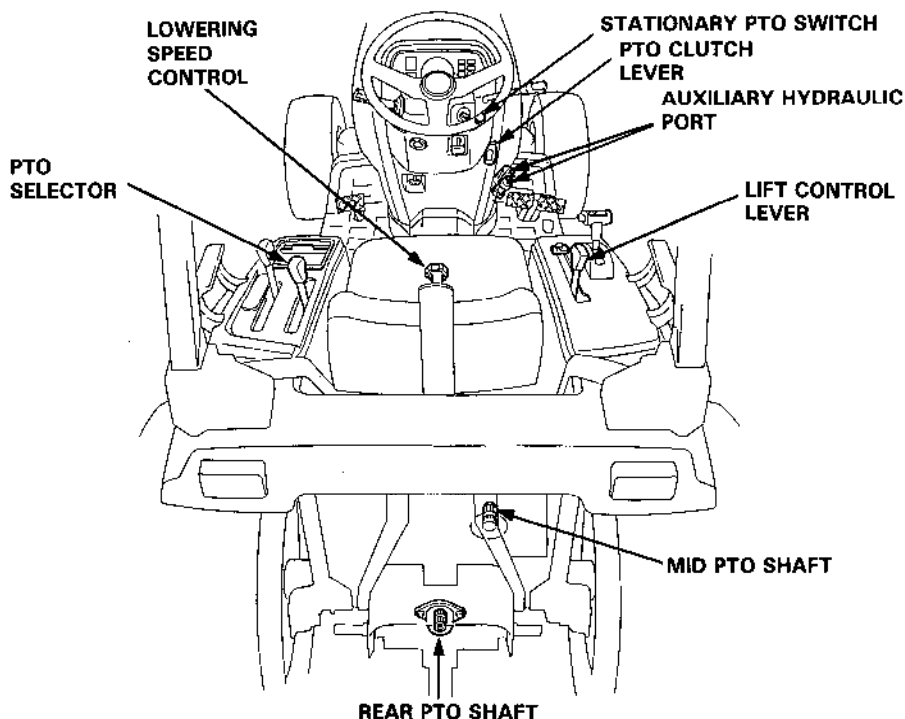

1. PTO clutch lever

Use the PTO (Power Take Off) clutch to connect engine power to the various PTO shafts.

Lever positions:

"ON" — Connects power to the PTO (s).

"OFF" — Disconnects power from the PTO (s).

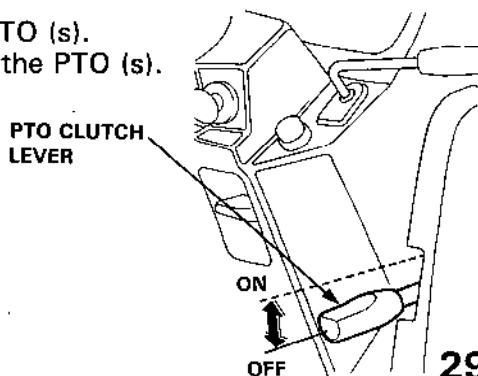

2. PTO Selector

Power may be transmitted to the rear PTO shaft, the mid PTO shaft, or both. Before moving the PTO Selector, place the PTO Clutch Lever "OFF".

 Rear PTO is powered.

 Both PTOs are powered.

 Mid PTO is powered.

PTO SELECTOR

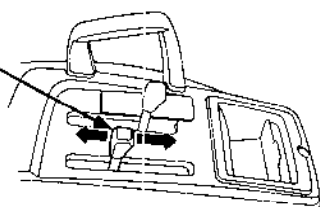

3. Stationary PTO Switch/Indicator

The rear PTO may be used to power various stationary attachments without an operator being seated.

To use the Stationary PTO:

1. Move the PTO Selector to "REAR" position. (The stationary PTO will not operate in "MID" or "BOTH" positions.)
2. Place the main transmission selector in neutral (N).
3. Set the parking brake.
4. Without sitting in the operator's seat, press the stationary PTO switch. The indicator light will come on.
5. The PTO clutch lever may now be moved "ON" or "OFF" from beside the tractor.
6. The stationary PTO will turn off when the operator sits in the seat and the indicator light will go off.

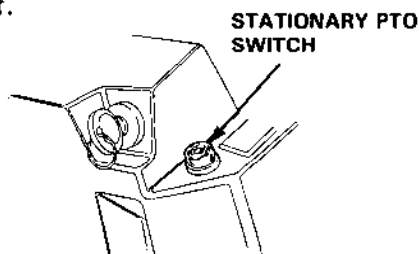
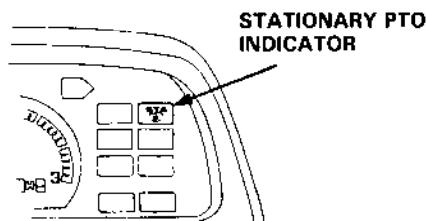

4. Rear PTO shaft/shaft cover

The rear PTO shaft transmits power from the engine to an attachment installed at the rear of the tractor.

Install the cover over the shaft whenever the rear PTO shaft is not used.

⚠ WARNING Operating the tractor without installing the cover over the shaft is very hazardous because clothing or other articles may be caught on the rotating shaft.

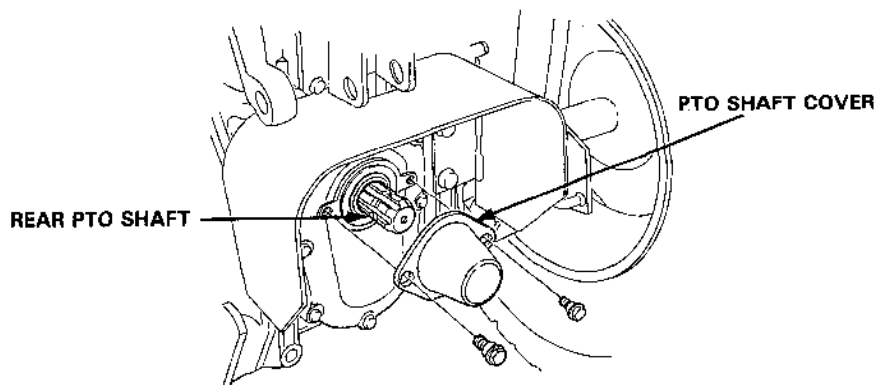

5. Lift control lever

The attachment can be raised and lowered to the desired position by operating the hydraulic lift lever.

The attachment can be raised only while the engine is running, but it can be lowered when the engine is stopped.

⚠ WARNING The attachment will descend when the hydraulic lift lever is moved to **DOWN** even if the engine is stopped with engine switch key removed from the engine switch.

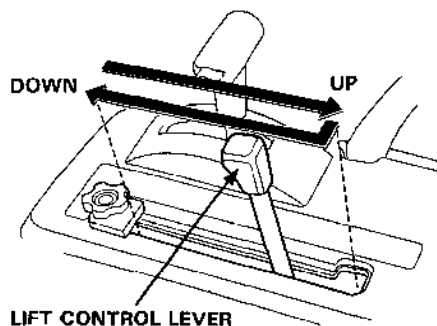

6. Lift control stop

Use the lift control stop to hold the attachment at the desired position. Determine the position where the attachment is lowered using the lift control lever and set the lift control stop at the position. The attachment can be returned to the position.

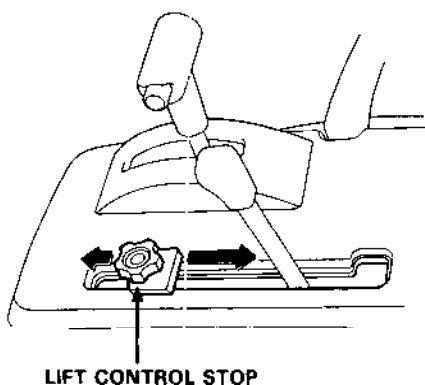

7. Lowering speed control

The lowering speed of the hydraulic lift system can be controlled by adjusting the lowering speed control. (Lift speed cannot be adjusted.) Adjust the lowering speed whenever you change attachments.

- Turning the knob clockwise slows the lowering speed.
- Turning the knob counter-clockwise increases lowering speed.
- Turning the knob fully clockwise stops any lowering of the lift system. Do not overtighten the knob.

To adjust the lowering speed:

1. Park the tractor on level ground with the engine running at about 1500 to 2000 RPM. Place the Main Transmission Selector in neutral and set the parking brake.
2. Turn the lowering speed control fully clockwise.
3. Move the Lift Control Lever to the "UP" position.
4. After the attachment has reached its maximum height, move the lift control lever to the "DOWN" position. The attachment should not lower.
5. Slowly turn the lowering speed control knob counter-clockwise to set the desired lowering speed. (It should take about 2 seconds for the attachment to move from its highest position to the ground.)

Lowering speed control knob turns 4 to 4.5 turns until it stops. There is a little free play when the knob is turned counterclockwise after it is turned clockwise to the full, and the attachment starts to lower from the position where the resistance is felt in the knob.

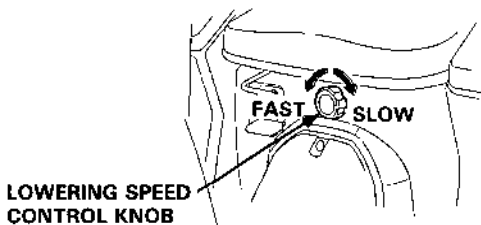

8. Auxiliary Hydraulic Port

Various attachments can receive hydraulic power from the tractor's hydraulic system through the auxiliary hydraulic port.

The hydraulic circuit operates automatically when the hydraulic pressure hose is connected to the port.

NOTICE

- **The precision components of the hydraulic system can be damaged by dirt and foreign material.**
- **Be sure to stop the engine when connecting the hydraulic coupler to the auxiliary hydraulic port.**
- **Be sure the connections and the area around the auxiliary hydraulic port is clean before connecting or disconnecting any attachment.**
- **Keep the provided connector covers installed when there is no attachment connected.**

The hydraulic system uses the same fluid as the transmission: DEXRON® II Automatic Transmission Fluid.

The use of any other type of fluid will cause damage to the hydraulic system or transmission.

NOTICE Any attachment connected to the auxiliary hydraulic port must have only DEXRON® II fluid in its system. If the attachment uses any other type of fluid, the fluid will mix with the DEXRON® II in the tractor's system. This will cause damage to the tractor's hydraulic system and transmission.

AUXILIARY HYDRAULIC PORT

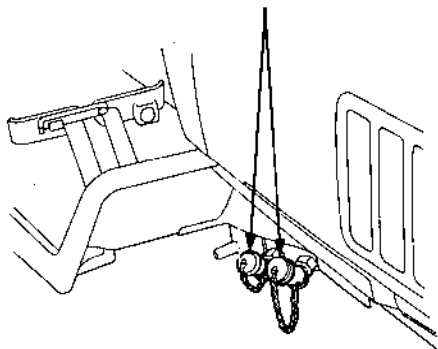

5. PRE-OPERATION CHECKS

For your personal safety and the service life of your equipment, always perform checks before using your tractor.

Before beginning a pre-operation check, be sure:

- The tractor is parked on a level surface.
- The parking brake is set, the main transmission selector is in neutral (N), and the PTO clutch lever is "OFF".
- Any attachment is lowered to the ground and the lift control lever is in the "DOWN" position.
- The engine switch key is removed.

WALK-AROUND CHECKS

Walk around the tractor and check its general condition.

Look around and underneath it for signs of fluid leaks.

Clean any excessive accumulation of dirt and debris, especially around moving components. Look for signs of damage. Check nuts, bolts, screws, and pins for tightness.

In particular, check the following items:

- Fuel level
- Tires/Wheels

1. Fuel level

Fuel tank capacity: 17 lit. (4.5 US gal, 3.7 Imp. gal)

Turn the engine switch ON and check the fuel gauge.

Refill the tank to the upper level if necessary. Do not fill the fuel tank above the upper level line.

Use **ONLY** clean high-quality fuel.

Recommended fuel specifications: ASTM D-975-1-D/2-D

Use No. 2-D fuel at temperatures above 40°F (4°C)

Use No. 1-D fuel at temperatures below 40°F (4°C)

Use No. 1-D fuel for all temperatures at altitudes above 5000 ft (1500 m).

Diesel fuel with a cetane rating as low as 40 may be used, but a cetane rating of 45 is recommended.

Do not use contaminated diesel fuel.

Do not mix different grades of diesel fuels.

Avoid getting dirt, dust or water in the fuel tank.

After refueling, be sure to tighten the fuel tank cap securely.

▲ WARNING

- **Diesel fuel is flammable and explosive under certain conditions. Refuel in a well ventilated area with the engine stopped.**
- **Do not smoke or allow flames or sparks in the area where the engine is refueled or where diesel fuel is stored.**
- **Do not overfill the tank, and make sure the filler cap is securely closed after refueling.**
- **Be careful not to spill fuel when refueling. Spilled fuel vapor may ignite. If fuel is spilled, make sure the area is dry before starting the engine.**
- **Use diesel fuel only. Do not use gasoline, kerosene or any other fuel oils. Do not mix gasoline with diesel fuel.**

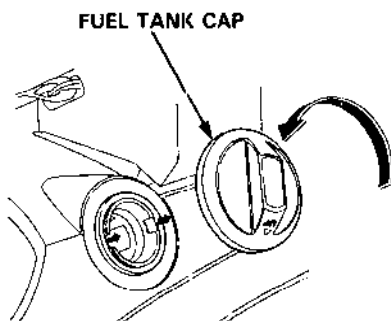

NOTE: Do not remove the fuel strainer when filling the tank from portable can.

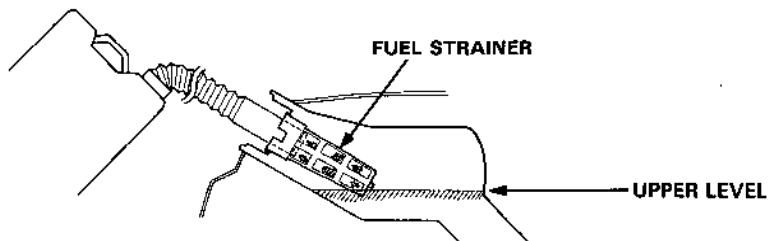

After refueling, tighten the filler cap securely with the "UP" mark facing up.

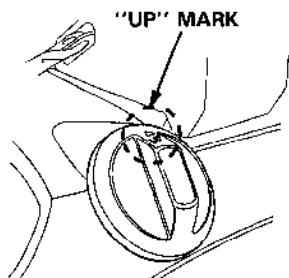

NOTE: Fuels vary in their formulation depending on season and location. Always purchase fresh fuel.

- A summer-grade fuel which is used in winter may solidify and prevent the engine from running.
- A winter-grade fuel used in summer can result in a lack of power and may not sufficiently lubricate fuel-injection components.

Keep the fuel tank filled to prevent condensation of water in the tank. Bacteria can grow at the fuel/water interface and clog fuel injection components.

Check the fuel filter for dirt, water, and contaminants before each use. If any contamination is found, follow the instructions on page 102.

Air Bleeding

The fuel injection system is equipped with an automatic air bleeding system in the event the engine is run out of fuel. Refill the tank (see page 36). Make sure that fuel is supplied to the fuel filter, then start the engine (see page 54).

NOTE: Light blue exhaust will be seen and the engine speed may fluctuate as air bleeding is occurring. This is normal. Run the engine without a load until the engine speed stabilizes and the exhaust smoke clears.

2. Tires/wheels

- Check the tire pressure with a pressure gauge.
Turf tire pressure: Front 1.55 kg/cm² (22 psi)
Rear 1.41 kg/cm² (20 psi)
AG tire pressure: Front 2.11 kg/cm² (30 psi)
Rear 1.41 kg/cm² (20 psi)
High float tire pressure: Front 1.12 kg/cm² (16 psi)
Rear 1.97 kg/cm² (28 psi)
- Check that the lug nuts and bolts on each wheel are securely tightened.
Torque: Front wheel 13 kg-m (94 ft-lb)
Rear wheel 18.5 kg-m (134 ft-lb)

NOTICE

- **Every day, check the lug nuts and bolts daily for security for the first 20 hours of operation, and retighten if necessary. Thereafter, re-check and retighten them every 50 hours.**
- **The tire might come off the rim if the air pressure is too low. Loose wheel nuts and bolts might cause the wheel to drop off.**
- Check side wall and tread surface of each tire for cracks, damage, or excessive wear.

UNDER-HOOD CHECKS

1. Opening/closing the hood

To open the hood, pull the hood release knob and lift the hood. Secure the hood with the hood support rod.

⚠ WARNING The hood can accidentally close in a strong wind unless it is secured with the hood support rod.

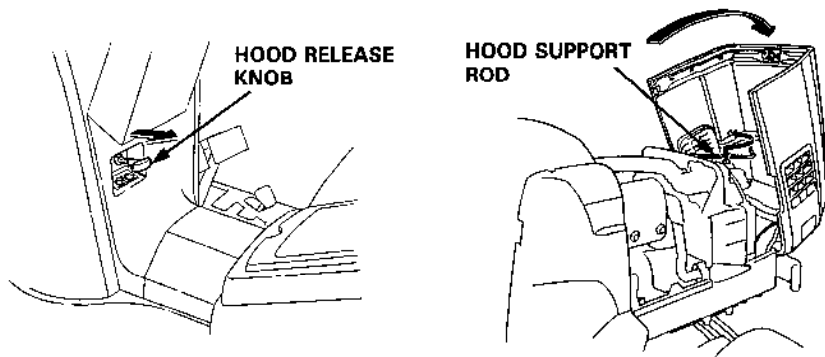

To close, take the support rod down and return it to its clip. Lower the hood slowly, then close it securely by pushing on it.

Hood removal/installation

Disconnect the headlight wiring connector located near the right hood hinge. From its fully opened position move the hood slightly toward its closed position and raise it up, out of its hinges.

To install the hood, align the hook with the hinge pin on the hood, lower the hood slowly to set it in its fully open position. Secure the hood with the support rod and connect the headlight wiring connector.

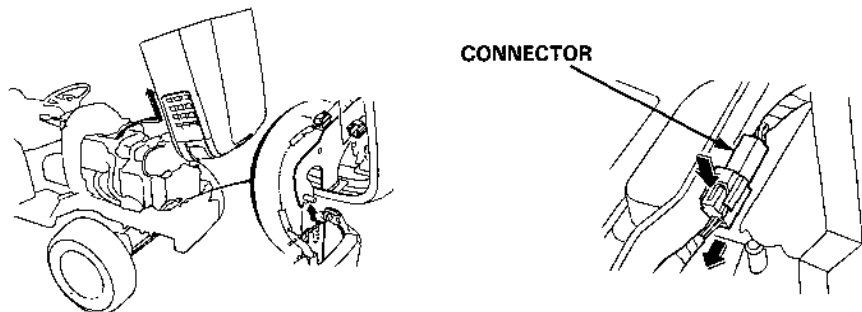

2. Side column cover removal

Open the hood, remove the nut and bolt, and pull the side column cover up. Then, the side column cover can be removed.

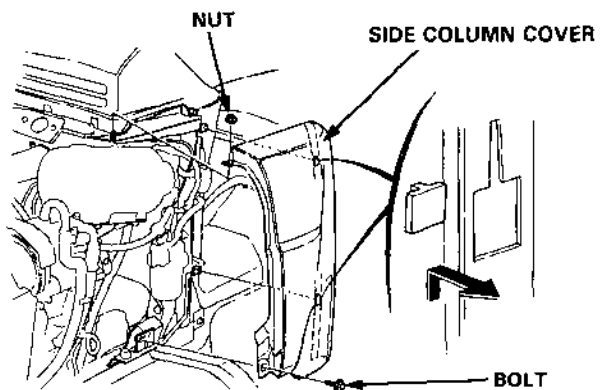

The side column cover can be installed in the reverse order of removal.

3. Engine Oil

NOTICE Engine oil is a major factor affecting engine performance and service life. Running the engine with insufficient oil can cause serious engine damage. Non-detergent oil and 2-stroke engine oil are not recommended.

SAE 10 W-30 diesel oil certified to meet or US automobile manufacturer's requirements for API Service Classification CC or CD (Diesel oils intended for Service CC or CD will show this designation on the container). SAE 10 W-30 is recommended for general, all temperature use. Select the appropriate viscosity for the average temperature in your area.

NOTE: Use the SAE 5 W-30 diesel engine oil when the ambient temperature is -20°C (-4°F) or below.

1. Place the tractor on a level surface.
2. Open the hood and clean the engine block around the dipstick. Remove the dipstick and wipe it clean.
3. Insert the dipstick with the handle ring of the dipstick toward down.
4. Check the oil level shown on the dipstick. If near or below the lower level mark, fill to the upper level mark with the recommended oil.
5. Install the oil level dipstick securely.

■ OIL: API CE, CD, CDII, CC

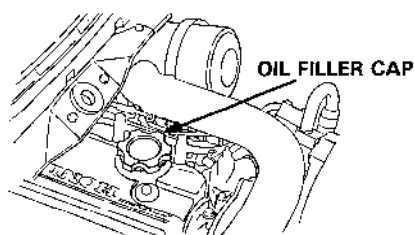
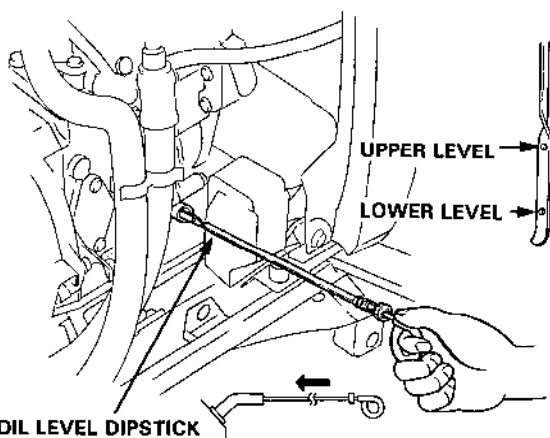
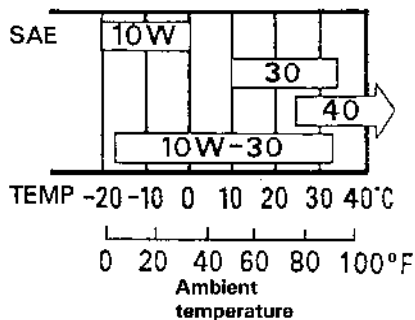

4. Coolant

Open the hood and check the coolant level in the reserve tank. If the level is near the MIN level, add coolant to bring it up to the MAX level.

Coolant Recommendation

Use high quality ethylene glycol antifreeze that is specifically formulated for use in aluminum engines. Mix the antifreeze with low-mineral drinking water or distilled water.

A 50/50 mixture of ethylene glycol antifreeze and water is recommended for most temperatures and provides good corrosion protection. A higher concentration of antifreeze decreases cooling efficiency and is recommended only if additional protection against freezing is needed. A concentration of less than 40% antifreeze will not provide proper corrosion protection.

NOTICE The use of unsuitable antifreeze, hard water, or salt water will cause corrosion damage that will shorten the life of the engine.

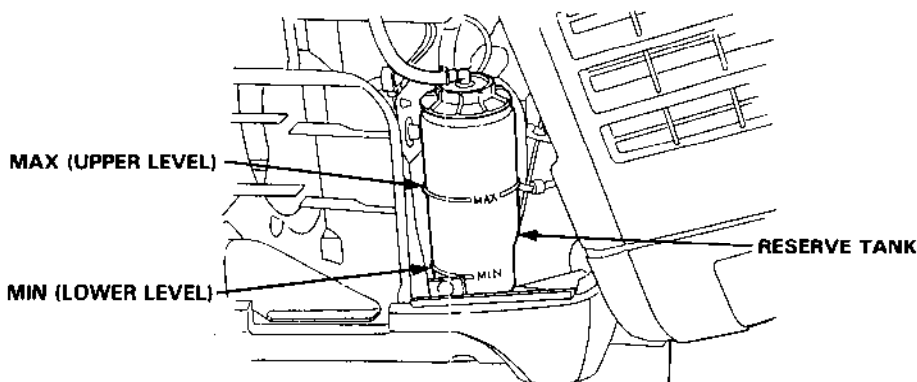

If there is no coolant in the reserve tank, the cooling system should be checked for leaks and repaired if necessary. Coolant must then be added to the radiator and reserve tank.

▲WARNING The coolant is hot and under pressure and severe scalding could result. Never remove the radiator cap when the engine is hot.

Wait until the engine is cool, then turn the radiator cap counterclockwise until it stops. DO NOT PRESS DOWN WHILE TURNING THE CAP. After any remaining pressure has been relieved, remove the cap by pressing down and again turning it counterclockwise. Add enough coolant to fill the radiator, and reinstall the cap. Be sure to tighten it securely. Fill the reserve tank up to the MAX level with the engine cold. Recheck the reserve tank once the engine reaches normal operating temperature.

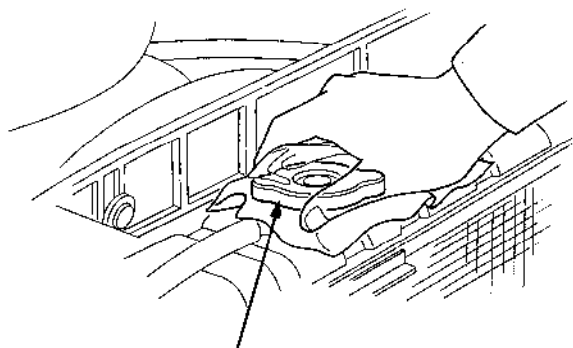

RADIATOR CAP

5. Battery electrolyte level

Open the hood, and check the battery electrolyte level.

The electrolyte level must be kept between the UPPER and LOWER level marks. If the electrolyte level is near the LOWER mark, remove the battery filler caps and carefully add distilled water to each cell until the liquid reaches the upper level line (see page 104).

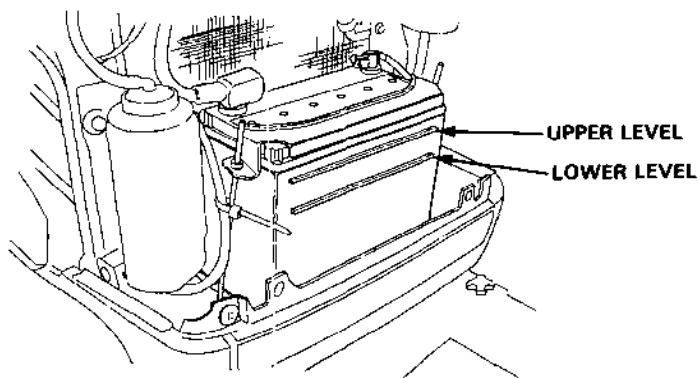

⚠ DANGER

- Batteries produce explosive hydrogen gas. A spark or flame can explode the battery causing serious injury or blindness.
Provide adequate ventilation.
Keep sparks and flames away.
Follow the above procedure carefully.
 - The battery contains corrosive sulfuric acid. Contact with eyes or skin causes burns.
Wear protective clothing and use eye protection when working near the battery.
- POISON-KEEP OUT OF REACH OF CHILDREN**
- EMERGENCY PROCEDURES:**
- | | |
|--------------|---|
| Eyes | — Flush with water from a cup or other container for at least 15 minutes. Call a physician immediately. |
| Skin | — Remove contaminated clothing. Flush skin with large quantities of water. Call a physician. |
| If swallowed | — Drink water or milk and call your poison control center or a physician immediately. |

6. Fuel Filter

Inspect the filter bowl for dirt, water, and other contaminants. Clean the filter if necessary (see page 102). Turn the fuel valve "ON".

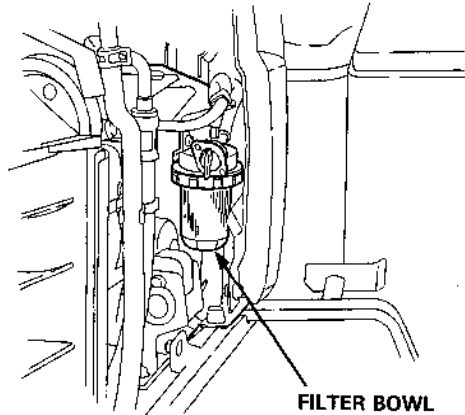

7. Fan belt

Check the belt for tension, damage, and wear. Push the center point of the belt with about 98N (22lb.) of force.

The belt should deflect 10–13mm (0.4–0.5in.). If the belt tension is incorrect, or if it is damaged or worn, contact your Honda compact tractor dealer.

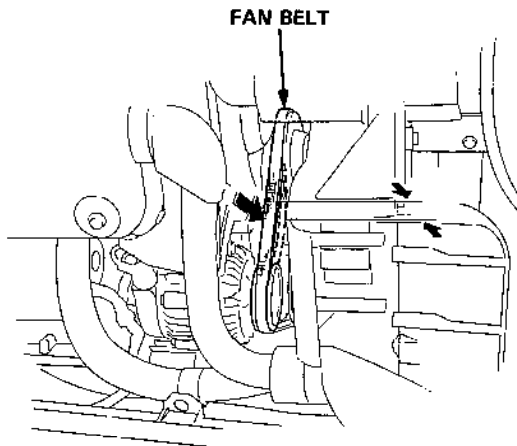

8. Power steering belt

Check the belt for tension, damage, and wear. Push the center point of the belt with about 98 N (22 lb) of force. The belt should deflect 7–10 mm (0.3–0.4 in). If the belt tension is incorrect, or if it is damaged or worn, contact your Honda Compact Tractor dealer.

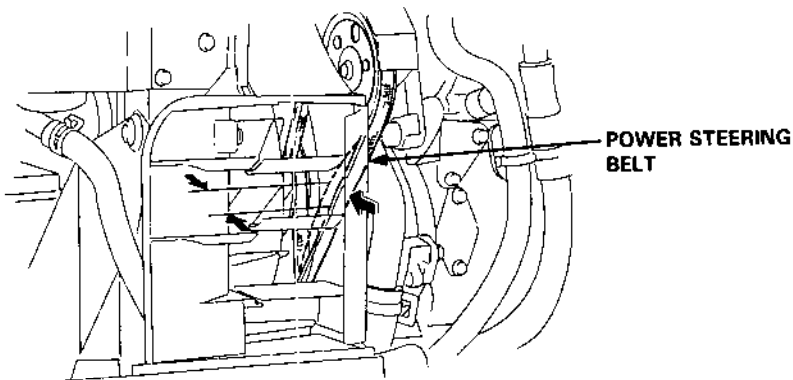

9. Radiator screen

Remove the screen from the front of the radiator. Clean dirt, leaves, and other obstructions from the screen and reinstall it.

Also remove any dry grass and leaves from the engine compartment. An accumulation of combustible materials around the engine, especially around the exhaust system, may ignite.

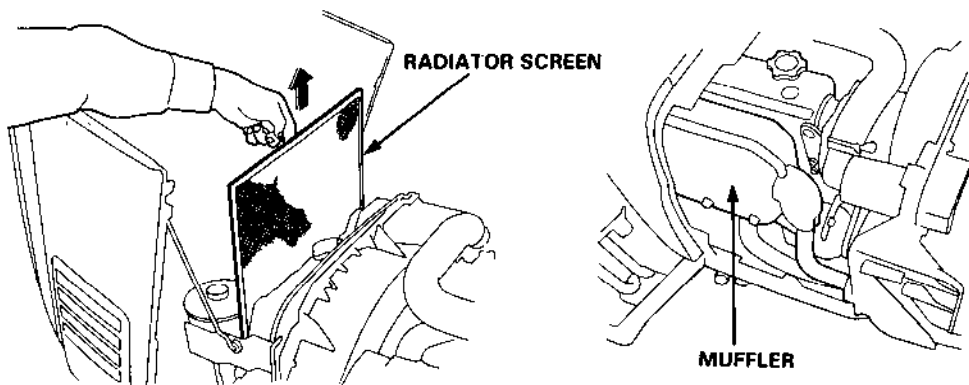

10. Battery under-tray

Remove the two knobs and pull out the under-tray. Clean dirt, leaves, and other obstructions from the screen and reinstall it. Tighten the two knobs securely.

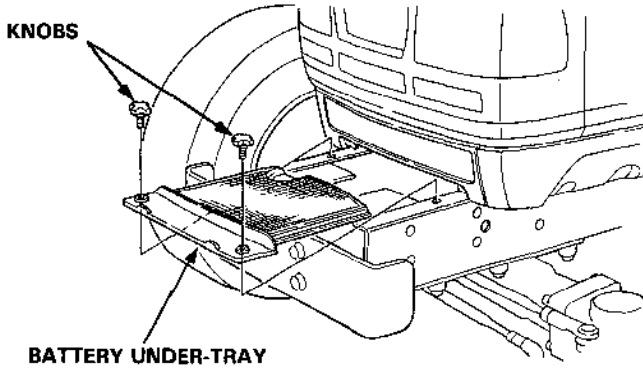

OPERATOR PLATFORM CHECKS

1. Steering

Push the steering wheel up and down and in and out. There should be no measurable movement.

With the front wheels pointing straight ahead, the free play at the rim of the steering wheel should not exceed 10–40 mm (0.4–1.6 in) before the front wheels start to move.

If excessive movement is found, contact your Honda compact tractor dealer immediately.

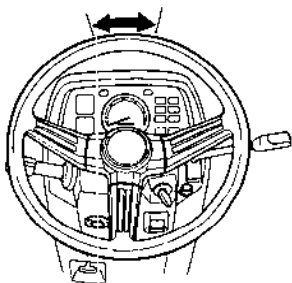

2. Lights

Turn the engine switch ON and perform the following inspections.

- (1) Check whether the headlights, corner lights, and taillights come on with the headlight switch set at (low beam) and (high beam) respectively.
- (2) Turn the flashing (hazard) light switch ON and check whether the flashing warning light comes on.

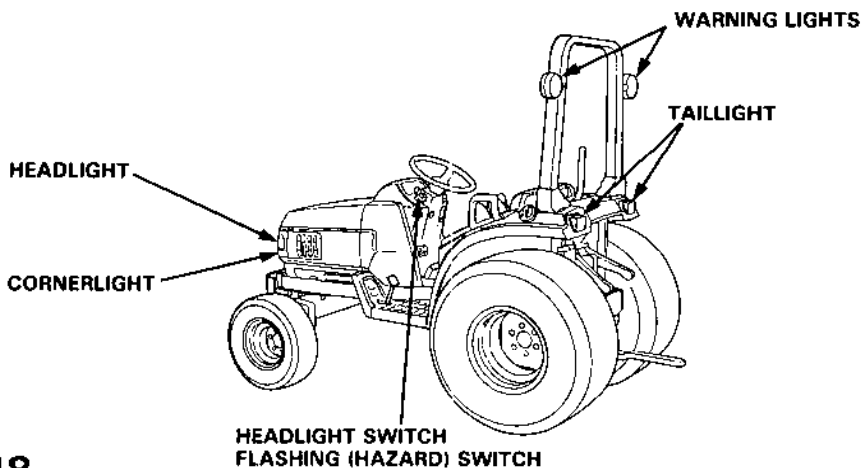

3. Clutch pedal

Measure the clutch free play from the fully released position to the point at which you feel resistance. The free play should be 15–20 mm (0.6–0.8 in). If the free play is out of adjustment, contact your Honda compact tractor dealer.

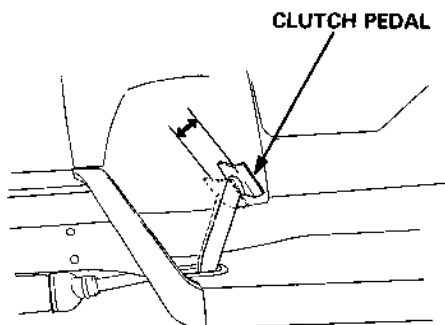

4. Brake pedal

Release the parking brake. Move the connector plate to separate the brake pedals. Push each brake pedal individually until resistance is felt. The free play should be 20–30 mm (0.8–1.2 in) and the free play should be the same for each pedal.

Move the connector plate to interconnect the brake pedals and set the parking brake. If the free play is out of adjustment, contact your Honda compact tractor dealer.

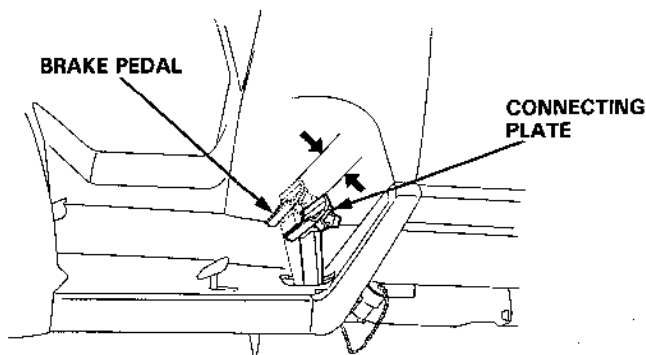

5. Parking brake warning buzzer

With the parking brake set, turn the engine switch "ON". Move the main transmission selector out of neutral (N). The warning buzzer should sound. The buzzer should stop when the parking brake is released.

Set the parking brake and turn the engine switch "OFF". If the system does not operate correctly, contact your Honda compact tractor dealer.

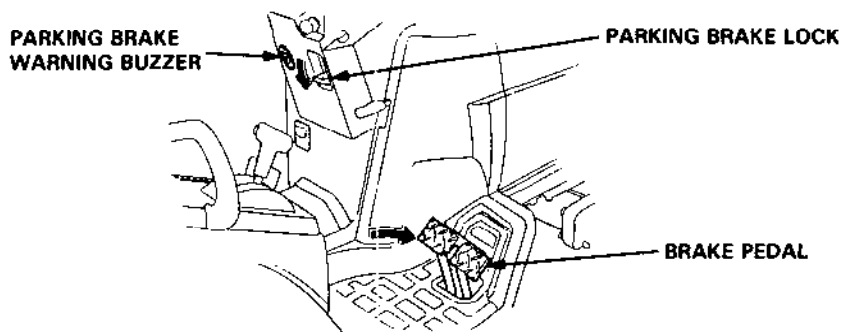

6. Safety interlock system

This tractor is equipped with a series of inhibitor switches which prevent the engine from being started unless the correct starting sequence is followed. Do not operate the tractor if any part of the interlock system does not operate correctly. If the system does not operate correctly, contact your Honda compact tractor dealer.

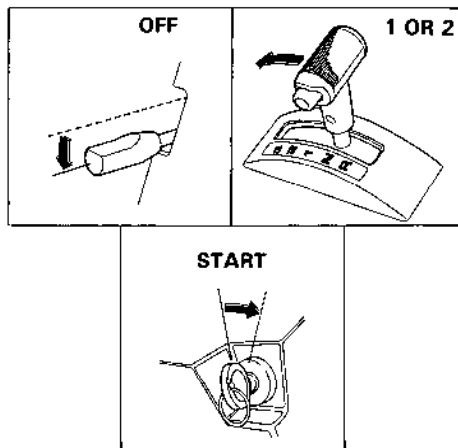

⚠ WARNING Be sure the area around the tractor is clear of people, pets, and obstructions. If there is a problem in the interlock system, the engine may start. Be ready to immediately shut off the engine.

Unless otherwise stated, conduct these checks while seated in the operator's seat.

Neutral switch

1. Set the parking brake
2. Move the PTO Clutch Lever to "OFF".
3. Move the Main Transmission Selector out of neutral (N).
4. Turn the engine switch to "START".

The engine should not start.

5. Turn the engine switch "OFF" and move the Main Transmission Selector to neutral (N).

PTO Clutch Lever

1. Set the parking brake
2. Move the PTO Clutch Lever to "ON".
3. Move the Main Transmission Selector neutral (N).
4. Turn the engine switch to "START".

The engine should not start.

5. Turn the engine switch "OFF" and move the PTO Clutch Lever to "OFF".

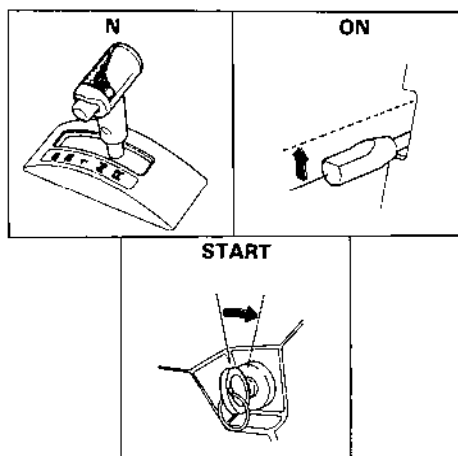

Brake switch

1. Release the parking brake
Keep your foot away from brake pedal.
2. Move the PTO Clutch Lever to "OFF".
3. Move the Main Transmission Selector to neutral (N).
4. Turn the engine switch to "START".

The engine should not start.

5. Turn the engine switch "OFF" and set the parking brake.

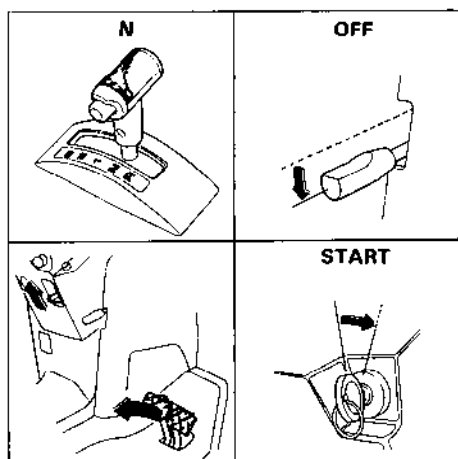

Seat switch

1. Set the parking brake
2. Move the PTO Clutch Lever to "OFF"
3. Move the Main Transmission Selector to neutral (N).
4. Rise up slightly from the seat and turn the engine switch to "START".

The engine should not start.

5. Turn the engine switch "OFF" and sit down.

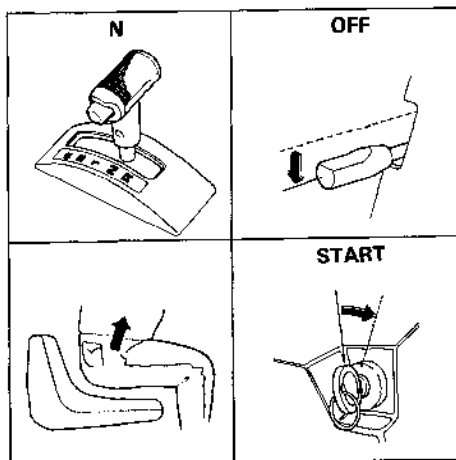

6. OPERATION

1. Starting the engine

▲WARNING Exhaust contains poisonous carbon monoxide gas that may cause loss of consciousness and lead to death. Never run the engine in an enclosed area. Be sure to provide adequate ventilation.

1. Open the hood and turn the fuel filter valve to "ON".
Close the hood.

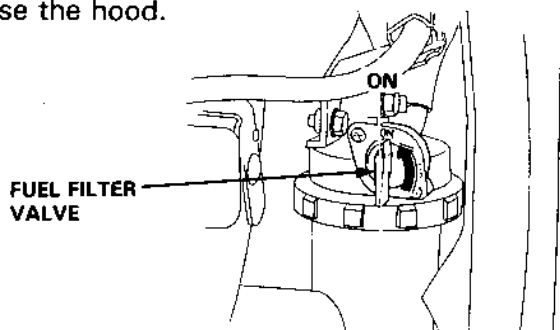

2. Adjust the seat to a comfortable position.

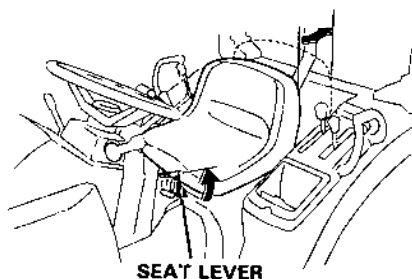

3. Set the parking brake.

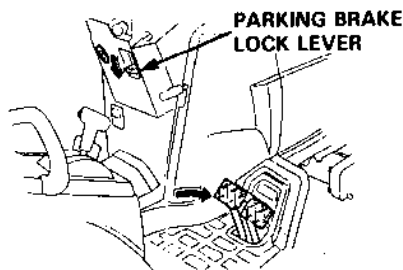

4. Move the main transmission selector to the "N", and the PTO clutch lever to the "OFF" position.

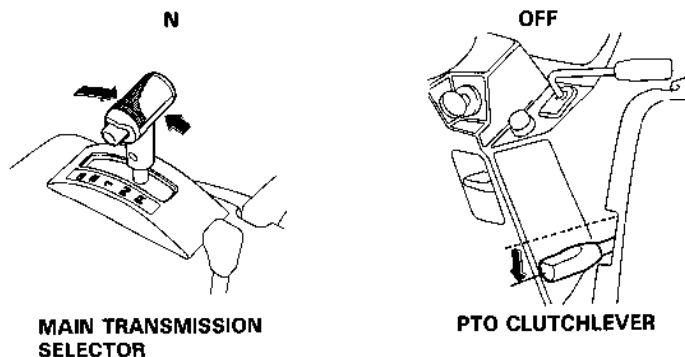

5. Move the throttle lever to the middle (1/2) position.

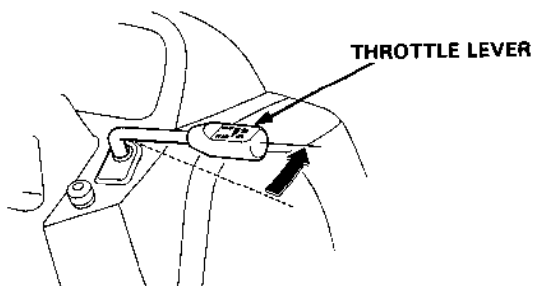

6. Turn the engine switch key to "START" and release the key when the engine starts.

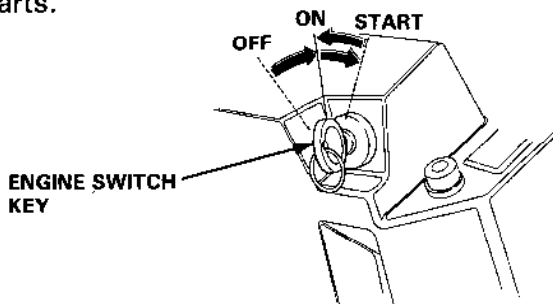

NOTICE Running the starter motor for more than 5 seconds can damage the motor.

If the engine fails to start, release the engine switch key, and wait at least 10 seconds before operating the starter motor again.

NOTE: If the brake pedal is depressed, the engine starts without locking the parking brake.

-
7. Return the throttle lever to the position where the engine speed becomes 1,000–1,500 r.p.m and warm up the engine for about 5 minutes.

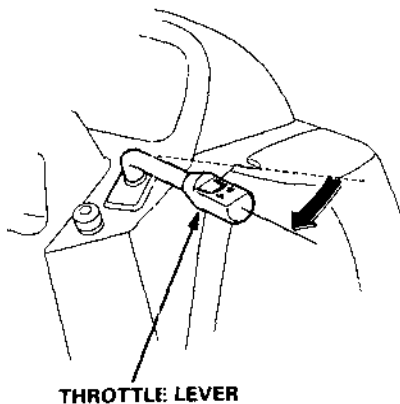

2. Starting/driving

▲ WARNING Before operating the Tractor or its attachments, read and understand the tractor safety instructions (see pages 5–12).

1. Interlock the brake pedals with the connector plate.

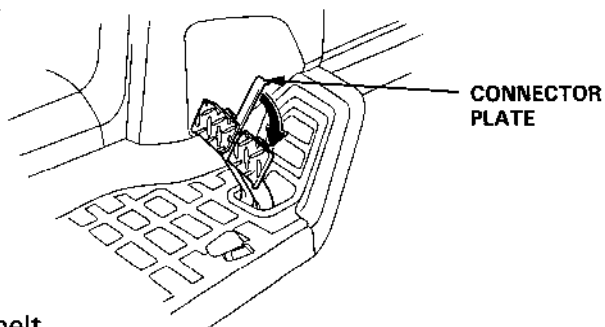

2. Wearing the seat belt.

▲ WARNING

- Wear the seat belt whenever operating the tractor with the Rollover Protective Structure attached.
- Use of either device (seat belt or ROPS) without the other will increase the chance of injury in a rollover.

Make sure that the seat belt is not twisted or kinked.

Push the tongue plate into the buckle until it clicks.

Sit erect and well back in the seat. Then adjust the belt to a snug fit by pulling out on the ends of the belt so the buckle is at the center of your body.

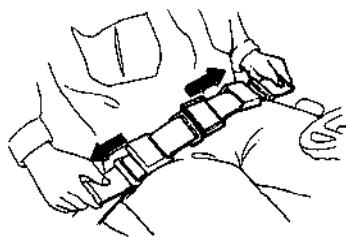
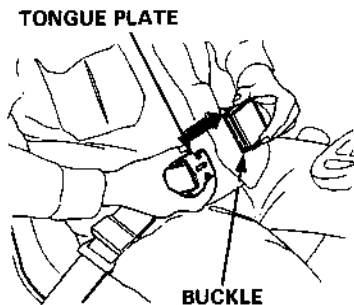

To release the seat belt, pull up on the buckle latch and pull out the tongue plate.

▲ WARNING Be sure that the belt is not twisted before fastening. The seat belt should be adjusted low across the hips and as snug as possible to provide proper protection.

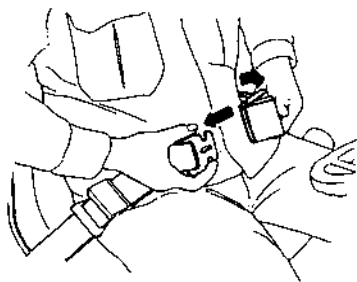

3. If a rear attachment is mounted and you are not planning to operate it soon, raise the attachment and turn the lowering speed control fully clockwise to lock the attachment up.

LIFT CONTROL LEVER

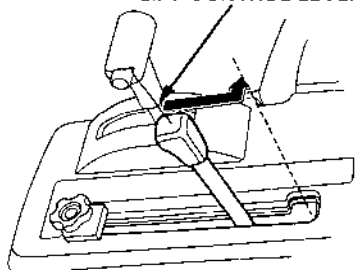

LOWERING SPEED CONTROL

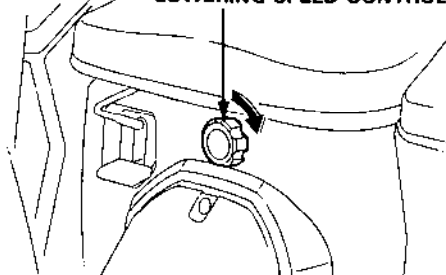

4. Move the throttle lever to "SLOW" and depress the clutch pedal. Move the transmission range selector to the desired range.

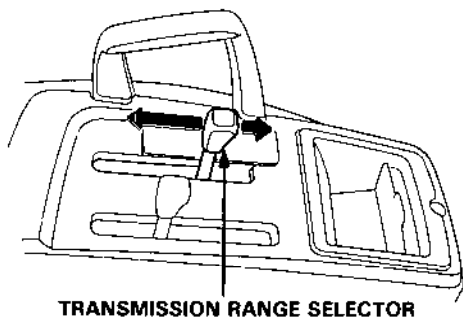
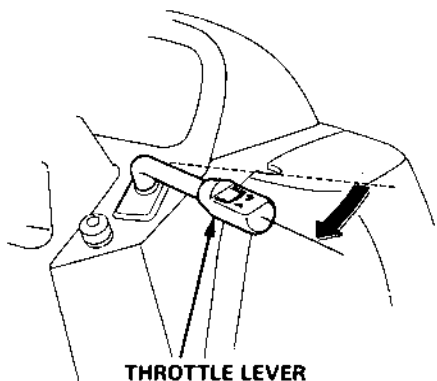

5. Move the main transmission selector to the desired speed. The lever cannot be moved from the neutral (N) position without pressing the button.

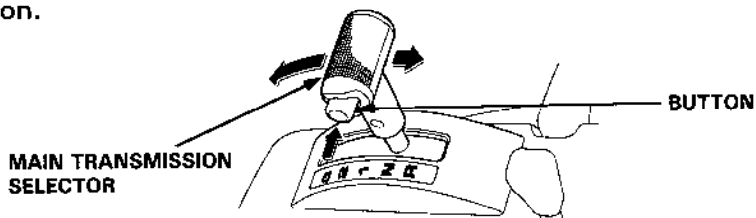

6. Release the parking brake. (The parking brake warning buzzer will sound if the parking brake is set and the main transmission selector is moved out of neutral.)
7. Increase the engine speed slightly with either the throttle lever or throttle pedal. Slowly release the clutch pedal.

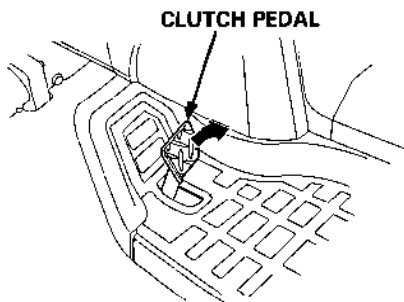
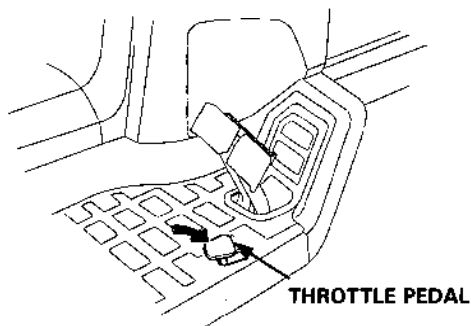

-
8. Adjust your speed using the main transmission selector and the throttle.

▲ CAUTION

- The main transmission can be moved from neutral to forward or reverse without depressing the clutch pedal however, the tractor will move more abruptly. Do not do this with the engine above idle speed, especially with the range selector in "3", to avoid a very abrupt start which may cause you to lose control.
- Set the throttle lever to the "SLOW" position when controlling the tractor with the throttle pedal. If the throttle lever is set above "SLOW", the engine speed will not drop to idle when the throttle pedal is released.

NOTICE

- Bring the tractor to a full stop before moving the main transmission selector from forward to reverse (or vice versa). The shock loads placed on the tractor could cause damage.
- Do not rest your foot on either the clutch pedal or differential lock pedal while the tractor is in motion. This can cause premature wear or damage of the clutch and differential lock.

3. Warm up and break in operation

Warm up

Let the tractor warm up for about 5 minutes after starting. This allows the engine, transmission, hydraulic, and power steering fluids and components to come up to normal operating temperature. Operating a "cold" tractor may cause premature wear of components.

Break in

Your Honda compact tractor has been carefully built and tested, but special care taken during its first 50 hours of operation will greatly extend its service life.

- Allow the tractor to fully warm up before operating it.
- Avoid sudden starts and stops.
- Avoid operating the engine at full speed or full load.

Hydraulic lift

If an attachment is mounted, check the lift system operation while the tractor is warming up.

Cycle the attachment up and down to check for smooth operation. Check the lowering speed and adjust if necessary.

5. Stopping the engine

- In an emergency:
Turn the engine switch OFF.
Depress the clutch and brake pedal.
- In normal use:
— 1. Move the throttle lever to "SLOW."

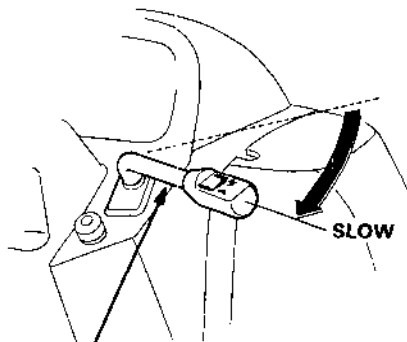

THROTTLE LEVER

- 2. Depress the clutch and brake pedals simultaneously.
Move the main transmission selector to "NEUTRAL".

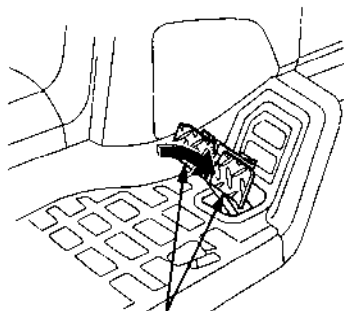

BRAKE PEDALS

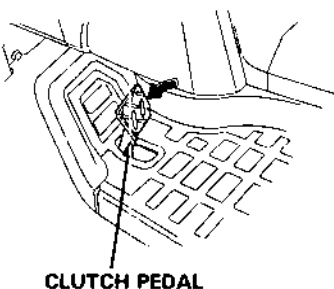

CLUTCH PEDAL

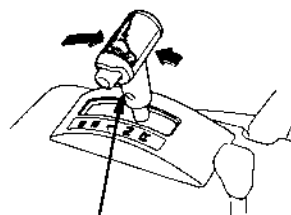

MAIN TRANSMISSION
SELECTOR

—3. Move the PTO clutch lever to OFF.

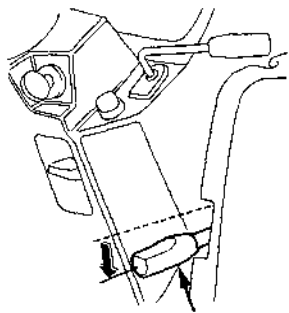

PTO CLUTCH LEVER

—4. Lower the attachment fully with the lift control lever.

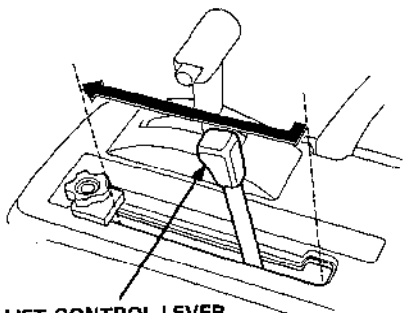

LIFT CONTROL LEVER

—5. Set the parking brake.

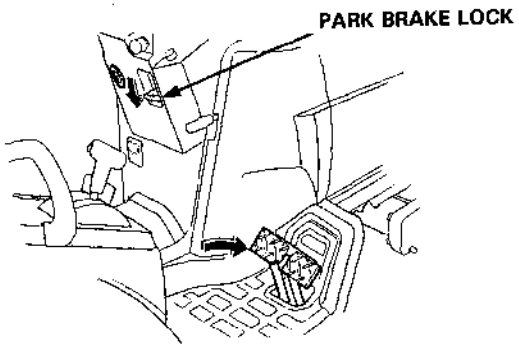

PARK BRAKE LOCK

—6. Turn the engine switch key to the OFF position and remove the key.

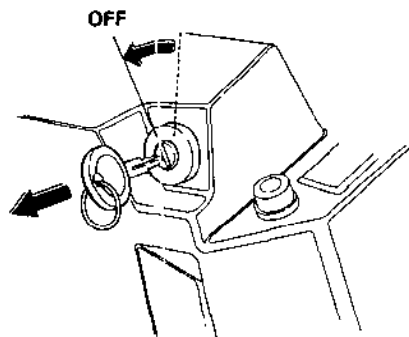

⚠ WARNING To avoid injury to yourself and others, before leaving the tractor unattended, **ALWAYS:** park on level ground, disengage the power take-off (PTO), lower the attachment, set the parking brake, stop the engine and remove the key.

6. Turning

⚠ WARNING Turning the tractor at excessive speed especially on uneven terrain can cause the tractor to tip over and you can be injured. Slow down before turning.

To prevent accidental tip over:

- Never make abrupt starts while the wheels are turned.
- Slow down before making sharp and/or hard turns.
- Avoid sharp turns in rutty or uneven terrain.
- Connect the right and left brake pedals with the connector plate except when making a tight turn by depressing one brake pedal.
- Engaging the differential lock while making sharp turns can cause you to lose steering control.
- Be sure to raise ground engaging attachments (rotary tillers, disk harrows, moldboard plows, etc.), before executing sharp turns. If the attachment is not raised, you can damage the tractor and/or the attachment.

NOTICE

- Rear attachments swing out in a larger arc than the tractor, and can strike nearby objects.
- Use care when turning the tractor near a wall or other obstructions when a rear mounted attachment is being used.

Using the brakes to turn

You can make tighter turns at slow speeds by using the brake on only one side of the tractor.

1. Move the connector plate to disconnect the brake pedals.

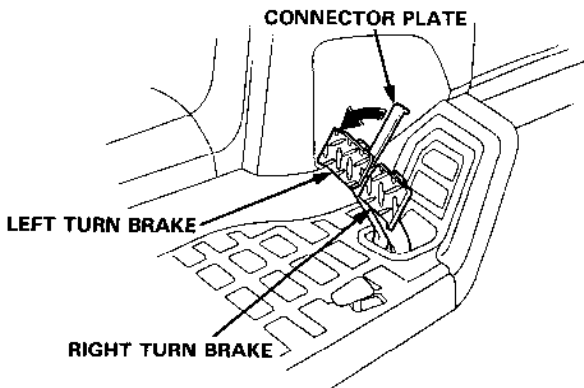

-
2. Slow the tractor and raise any attachment.
 3. While turning the steering wheel, depress the brake pedal on the side of the direction of the turn. (Left turn: left brake. Right turn: right brake.)
 4. Release the brake while returning the steering wheel to a straight-ahead position.

NOTICE Using the brakes to turn while on grass will tend to damage the turf.

7. How to use the differential lock

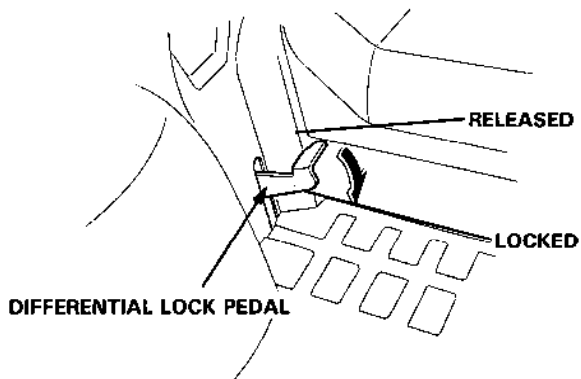

⚠ WARNING When used properly, the differential lock is extremely convenient. However, improper operation could cause the vehicle to overturn; it could also damage the drive train. Take care when using the differential lock.

The differential lock is most useful in situations where a slippery or loose surface causes one of the rear wheels to lose traction.

Operation

1. Shift the transmission range selector into 1st.
2. With the steering wheel held straight-ahead, depress and hold the differential lock pedal. As long as you continue to depress the pedal, the differential lock will be applied.
3. The differential lock should release when the differential lock pedal is released.

At times it may be necessary to stop, reverse direction, and drive a short distance to disengage.

-
4. To release the differential lock, remove your foot from the lock pedal, bring the tractor to a full stop, shift the main transmission from FORWARD to REVERSE or vice versa, and drive a short distance.

▲ WARNING The differential lock must be released before operating the tractor on hard surfaces or slopes, or while turning. Otherwise the tractor may overturn, causing severe personal injury.

NOTICE

To avoid damage to transmission mechanism.

- Do not apply the differential lock while the wheels are turning.
- Do not rest your foot on the differential lock pedal unless you want to engage the differential lock.
- Do not apply the brake and the differential lock at the same time.
- Check that the differential lock has been released after you have finished using it.
- Do not apply the differential lock while driving at high speed.
- Do not apply the differential lock on a hard packed surface.

8. Two and four-wheel drive selection (A4 type only)

Two or four wheel drive can be selected by operating the two/four wheel drive selector.

Prior to shifting, set the steering wheel in the straight-ahead position, bring the tractor to a complete stop and depress the clutch pedal fully.

NOTE: If difficulty is encountered in shifting the lever, re-engage the gears by driving the tractor a short distance in **FORWARD** with the clutch engaged.

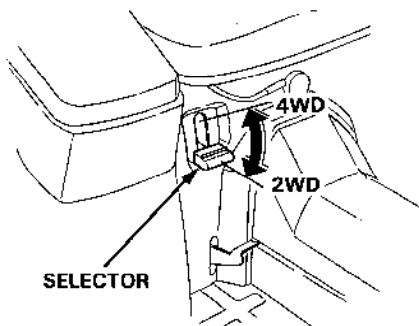

We recommend that you select the two wheel drive or the four wheel drive according to the terrain and conditions.

2-WHEEL DRIVE	Mowing and transport (when extra traction is not required)
4-WHEEL DRIVE	Towing, Operation on slope or soft ground, Operation with attachment installed (Especially when powerful driving force and braking force are required.)

NOTICE

- To prevent damage to the transmission mechanism, bring the tractor to a full stop before operating the shift lever.
- Driving in 4-wheel drive range or application of the differential lock on paved road or surface could cause premature wear on the tires; it could also impair fuel economy.
- When driving in four wheel drive, you have 4-wheel braking. When shifted into two wheel drive you have 2-wheel braking (rear only).

9. Use of power steering

- The power steering system operates only when the engine is running. Steering effort will increase when the engine is not running.
- When you turn the wheel fully left or right, a relief valve will open to relieve excess pressure. You will hear a high-pitched sound when this happens. Avoid this condition for prolonged periods to prevent damage to the steering system. Also avoid using excessive steering force when the front tires are caught in a furrow or trench to prevent rim and tire damage and possible tractor upset.
- Do not make large movements of the steering wheel when the engine is not running. Steering fluid will be forced from the system back to the reservoir and may cause the reservoir to overflow.

10. Attachment limitations

The use of Honda HTA attachments is recommended. If an attachment exceeds the weight limits described below, or if the counterweights used do not conform to the sizes and weights specified in "Counterweight Table", the operator may be hurt or the tractor may be damaged.

Never use attachments which exceed sizes and weights specified.

Never use counterweights other than those specified in Counterweight Table.

Any malfunction or damage to the tractor is unwarrantable if it is the consequence of use of attachments not specified or recommended by Honda.

• Attachment Limitations

Max. allowable load at end

of lower link	Max. lifting force at lift point: W_0
Front attachment weight	Max. front attachment weight which can be lifted hydraulically: W_1
Rear attachment weight	Max. rear attachment weight which can be lifted hydraulically: W_4
Trailer load	Total weight of trailer and max. allowable load on trailer: W_2
Tongue weight	Total weight or downward force on pivot point: W_3

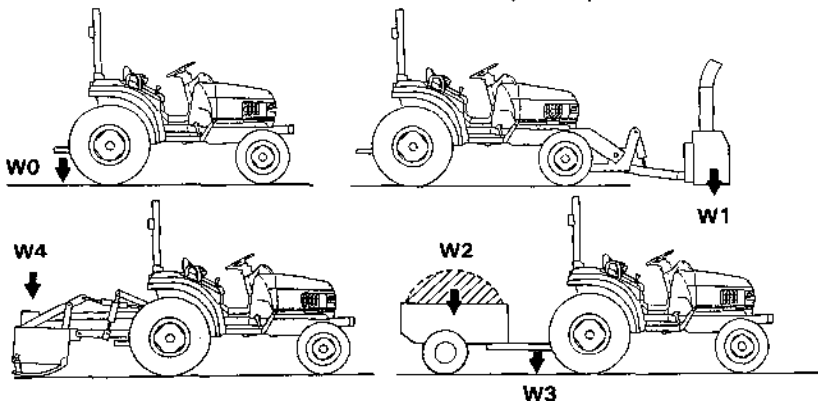

		4WD•2WD	
Max. load at lower link end (W0)		407 kg (896 lbs)	Installation should be based on "COUNTERWEIGHT TABLE." (see page 75)
Max. weight of front attachment (W1)		200 kg (441 lbs)	
Max. weight of rear attachment at rear 3P mount (W4)		340 kg (749 lbs)	
Trailer	Max. load (W2)	1,000 kg (2,205 lbs)	Weight of trailer included
	Tongue weight (W3)	40 ± 5 kg (88 ± 11 lbs)	As down force

Size and Weight Limits by Attachments

Attachment		Item	Weight and Size Limits
Rotary Mower	Mid 3-blade	Max. cutting width Max. weight	1,524 mm (60 in) 140 kg (309 lbs)
Snow Blower		Max. intake width Max. weight	1,448 mm (57 in) 166 kg (366 lbs)
Dozer Blade		Max. blade width Max. weight	1,524 mm (60 in) 94 kg (207 lbs)
Tiller		Max. cultivating width Max. weight	1,321 mm (52 in) 183 kg (403 lbs)
Trailer		Max. load	1,000 kg (2,205 lbs) (weight of trailer included)
Sweeper		Max. size Max. weight	1,524 mm (60 in) 156 kg (344 lbs)
Front end Loader		Bucket width Max lift capacity Max weight	1,321 mm (52 in) 249 kg (550 lbs) 285 kg (623 lbs)
Back Hoe		Digging depth Max. weight	2.3 m (7.5 feet) 409 kg (901 lbs)

NOTE: The above limits are applicable if only one attachment is used on the tractor.

• Towing

▲ WARNING

- **Never attempt to tow anything without a trailer hitch. Failure to use a proper hitch could cause the tractor to overturn resulting in severe personal injury or equipment damage.**
- **Never allow anyone to ride in the trailer.**
- **Traveling and turning at high speeds while towing a trailer or other attachment is dangerous. Use 1st gear when towing a trailer or attachment over rough ground.**
- **Avoid sudden starts and stops while towing. The momentum of the trailer or attachment could cause loss of control resulting in an accident and severe personal injury or equipment damage.**
- **The weight of a trailer increases stopping distances; use extra care, especially when operating on a slope.**

Use only those attachments which are designed for use with this tractor (Category 1). If you have any questions or doubts about the suitability of any other attachments, consult your authorized Honda compact tractor dealer.

NOTICE

The removal of any rear attachment is necessary when using the draw plate for towing. If the rear attachment is not removed, damage to the tractor and/or the attachments can occur.

1. Maximum towing weight:

1,000 kg (2,205 lbs) including the weight of the trailer.

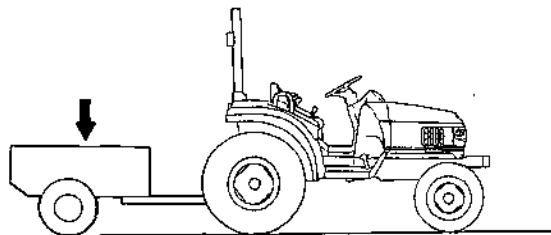

▲ WARNING

Exceeding the maximum towing weight could lead to loss of control and cause an accident resulting in severe personal injury or equipment damage.

-
2. Maximum tongue weight:
40 kg \pm 5 kg (88 lbs \pm 11 lbs)

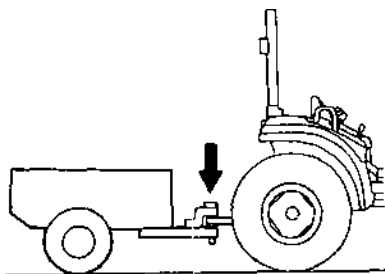

▲WARNING If the trailer's load is unbalanced so that the tongue weight is incorrect, the tractor may overturn resulting in severe personal injury or equipment damage.

NOTE: Tongue weight is the downward force that the trailer exerts on the trailer hitch.

- **Counterweight and recommended tire**

When an attachment is mounted, the weight and balance of the tractor may be affected. The specified counterweights must be used to maintain the stability of the tractor.

⚠ WARNING Under no circumstances should the total weight of the attachment, counterweights and wheel weights exceed 1,150 kg (2,533 lbs). Failure to follow this precaution may endanger yourself, and may cause damage to your tractor or shorten its service life.

The total number of the counterweights needed for each HTA attachment are shown in the table below.

HTA Attachment	Number of counterweights/recommended tire			
	4WD		2WD	
	counterweights	tire	counterweights	tire
Mid-Mount Rotary Mower	None	Turf	None	Turf
Front Snow Blower	Rear counter weight box and sand 90 kg (198 lbs)	AG	Rear counter weight box and sand 90 kg (198 lbs)	AG
Snow Dozer	Rear counter weight box and sand 10 kg (22 lbs)	AG	Rear counter weight box and sand 10 kg (22 lbs)	AG
Sweeper	Rear counter weight box and sand 90 kg (198 lbs)	AG	Rear counter weight box and sand 90 kg (198 lbs)	AG
Tiller	Front counter weight bracket and counter weight 1 piece	AG	Front counter weight bracket and counter weight 1 piece	AG

NOTE:

- Use of turf tires on the front end loader or agricultural tires on the front/mid mower is not recommended as such practice may affect the performance of the equipment.
- Use the counterweights shown in the table above even if the tires other than AG or Turf tires are used.

Use the following combinations of ballast with the FL 6555 front loader and the BH 6575 backhoe.

FL 6555 Front loader

Counter weight box: 272 kg (598 lbs) of sand.

Liquid tire ballast:

Ag tire	Turf and Hi-Float tire
45 kg (100 lbs) per rear wheel	107 kg (236 lbs) per rear wheel

Rear wheel weight:

Ag tire	Turf and Hi-Float tire
One 27 kg (60 lbs) per rear wheel	None required

FL 6555 Front loader and BH 6575 Backhoe

Liquid tire ballast:

Ag tire	Turf and Hi-Float tire
45 kg (100 lbs) per rear wheel	107 kg (236 lbs) per rear wheel

Rear wheel weight:

Ag tire	Turf and Hi-Float tire
One 27 kg (60 lbs) per wheel	None required

Installation of Weight

- Operation with front attachment

When the front loader, front snow blower, front snow dozer or front sweeper is used with the tractor, purchase the rear 3-point hitch and rear counter weight box and operate the front attachment or drive to and from the operating area with the box filled with sand as a weight. The 3-point hitch and rear counter weight box are available as optional parts.

Operation with rear attachment

When the tiller or other rear attachment is used with the tractor, use the optional counter weight bracket and counterweights as specified.

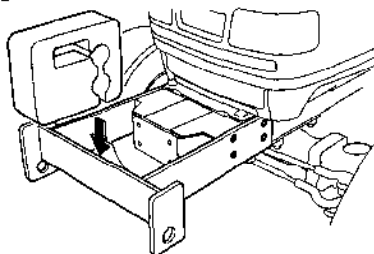

Use the table below and determine the number of the counterweights for the attachments other than listed in the previous page.

1. Rear Attachment and Counterweight Table.

The number in the box indicates the number of counterweights required.

NOTE: This table is based on each counterweight weighing approximately 16 kg (35 lbs).

W \ L	800 mm (32 in)	1000 mm (39 in)	1200 mm (47 in)	1400 mm (55 in)
80 kg (176 lbs)	0	0	0	0
100 kg (220 lbs)	0	0	0	1
120 kg (264 lbs)	0	0	1	1
140 kg (308 lbs)	0	1	1	3
160 kg (352 lbs)	1	1	3	4
180 kg (396 lbs)	1	2	4	6
200 kg (440 lbs)	1	3	5	7
220 kg (484 lbs)	2	4	6	*
240 kg (528 lbs)	3	5	7	*
260 kg (572 lbs)	3	6	*	*
280 kg (616 lbs)	4	7	*	*
300 kg (660 lbs)	5	7	*	*
320 kg (704 lbs)	6	*	*	*
340 kg (748 lbs)	7	*	*	*
360 kg (792 lbs)	*	*	*	*

L: Distance between center of attachment side wheel and center of gravity of attachment.
 W: Weight of attachment
 C.G.: Center of gravity

Any attachments which exceed the sizes and weights shown in the table to the left should not be used.

0: Counterweight unnecessary
 *: Attachment should not be used

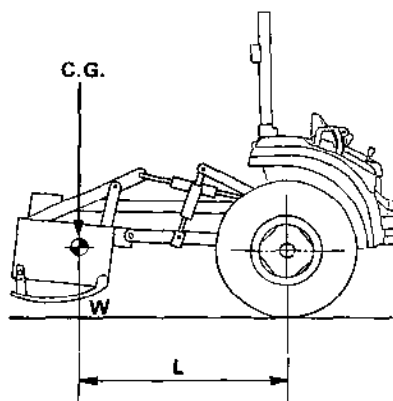

2. Front Attachment and Counterweight Table.

Fill the rear counterweight box with sand in accordance with the instructions given in the table below.

W \ L	800 mm (32 in)	1000 mm (39 in)	1200 mm (47 in)	1400 mm (55 in)
100 kg (222 lbs)	0	10 kg	25 kg	35 kg
120 kg (267 lbs)	20 kg	35 kg	30 kg	60 kg
140 kg (311 lbs)	40 kg	55 kg	70 kg	*
160 kg (352 lbs)	60 kg	75 kg	*	*
180 kg (396 lbs)	75 kg	*	*	*
200 kg (440 lbs)	95 kg	*	*	*
220 kg (484 lbs)	*	*	*	*

L: Distance between center of attachment side wheel and center of gravity of attachment.

W: Weight of attachment

C.G.: Center of gravity

Any attachments which exceed the sizes and weights shown in the table to the left should not be used.

0: Counterweight unnecessary

*: Attachment should not be used

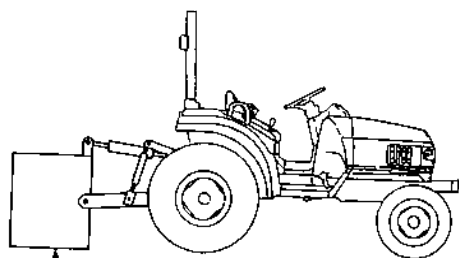

COUNTERWEIGHT BOX

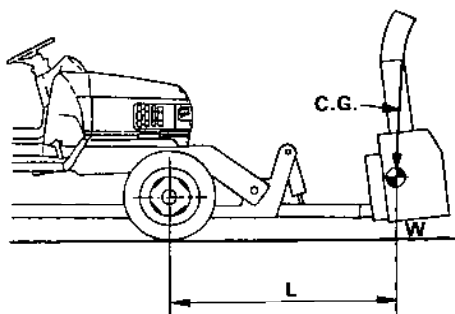

11. Operation on a slope

Before starting up or down a long incline, select one of the lower gear ranges, so that tractor speed is reduced, but engine speed is high for maximum control.

▲ WARNING

- **Driving across the face of a slope can cause the tractor to tip over and you can be injured. Always drive up or down a slope.**
- **Making turns on a slope can cause the tractor to tip over and you can be injured. Drive straight up or straight down slopes.**
- **Changing gears while driving on a slope can cause loss of control. Shift to a lower gear before approaching a slope.**
- **Engagement of the differential lock while driving on a slope can cause loss of control.**
- **Avoid parking on a slope. If necessary, apply the parking brake and place blocks on the downhill side of each wheel.**

12. Uphill starting procedure

If possible avoid stopping the tractor while driving uphill. If it is necessary to stop on a hill, follow the special procedure below when restarting:

▲ WARNING

- If this procedure is not followed when restarting on an uphill slope the tractor may roll backwards during clutch engagement, and this could cause it to tip over resulting in severe personal injury.
- Abruptly applying the brake pedal while the tractor is rolling backwards down a slope may cause the tractor to tip over.

- 1. Depress the brake pedal and hold it down.
- 2. Move the throttle lever to "FAST" position.
- 3. Depress the clutch pedal and then move the transmission range selector to 1st gear position.
- 4. Release the clutch pedal first, then release the brake pedal.

▲ WARNING

If the brake pedal is released before the clutch pedal, the tractor may back down. Never apply the brakes hard. It may cause the tractor to tip over.

• Special Obstacles:

- 1. To safely cross drainage ditches or embankments, use a ramp to reduce the effective angle of the obstacle to less than 15°

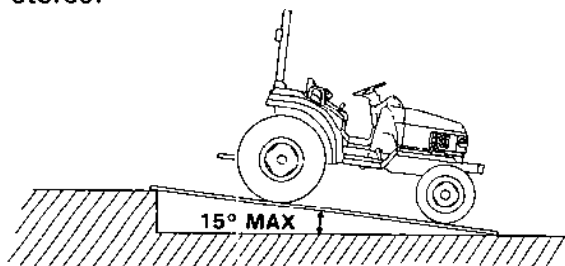

NOTE: If you feel that you cannot accurately judge angle of the ramps, we suggest that you obtain an inclinometer. This type of gauge is available at most hardware stores.



- 2. Avoid swampy or muddy areas deep enough to reach the center line of the wheels. The tractor can become stuck, especially if it is carrying attachments.

13. Recommended working speed

Select a safe and correct operating speed as per the instructions shown in the chart below.

Km/h	1	2	3	4	5	6	7	8	9	10	11	12	13	14	15	16	
mile/h	1	2	3	4	5	6	7	8	9	10	11	12	13	14	15	16	
	▲▲	▲▲	▲▲	▲▲	▲▲	▲▲	▲▲	▲▲	▲▲	▲▲	▲▲	▲▲	▲▲	▲▲	▲▲	▲▲	
 MAIN TRANSMISSION SHIFT RANGE	1	2	3	1	2	3	1	2	3	1	2	3	1	2	3	1	3
 TRANSMISSION RANGE SELECTOR SHIFT RANGE	1	1	2	2	2	2	3	3	3	3	3	3	3	3	3	3	3
	<div style="border: 1px solid black; padding: 5px; display: inline-block; margin-bottom: 10px;">◀ MID MOWER ▶</div> <div style="border: 1px solid black; padding: 5px; display: inline-block; margin-bottom: 10px;">◀ FRONT END LOADER ▶</div> <div style="border: 1px solid black; padding: 5px; display: inline-block; margin-bottom: 10px;">◀▶ TILLER</div> <div style="border: 1px solid black; padding: 5px; display: inline-block; margin-bottom: 10px;">◀▶ SNOW BLOWER</div> <div style="border: 1px solid black; padding: 5px; display: inline-block; margin-bottom: 10px;">◀ FRONT BLADE ▶</div> <div style="border: 1px solid black; padding: 5px; display: inline-block; margin-bottom: 10px;">◀ SWEEPER ▶</div> <div style="border: 1px solid black; padding: 5px; display: inline-block; margin-bottom: 10px;">◀ TRAILER ▶</div> <div style="border: 1px solid black; padding: 5px; display: inline-block;">◀ REAR MOWER ▶</div>																

* The gear range listed above is for an engine speed is 2,600 rpm.

7. TRANSPORTING

Transporting

WARNING The engine and exhaust system become hot during operation and remain hot for a while after stopping. Contact with hot engine components or the exhaust system can cause burns and can ignite some materials.

Avoid touching the engine or exhaust system for at least 15 minutes after the engine has stopped. Allow the engine to cool before transporting the tractor.

NOTICE Towing the tractor behind another vehicle or using it to push another vehicle can damage the tractor.

Transport the tractor on a flat, heavy duty trailer. To avoid fuel spillage, keep the tractor level while transporting.

Some attachments, such as a mid-mount mower, have a low center clearance. You may have to adjust the ramp angle at the bed to avoid interference.

1. Use a loading ramp that is strong enough to support the combined weight of the tractor, its attachments and the operator. The loading ramp must be long enough so that its slope is 15° or less.
2. Move the main transmission selector to the R, and transmission range selector to the 1st to back the tractor up the ramp.

NOTE: If you feel that you cannot accurately judge angle of the ramps, we suggest that you obtain an inclinometer. This type of gauge is available at most hardware stores.

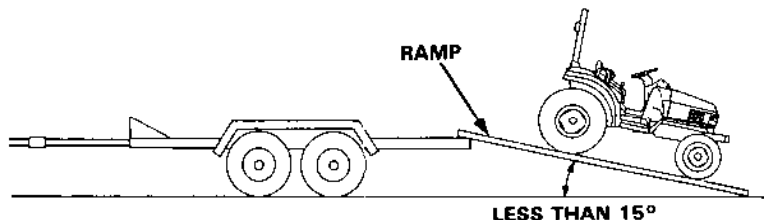

NOTE: If the engine stalls during loading, immediately depress the brake pedal and clutch pedal, then let the tractor roll down the ramp by slowly releasing the brake pedal.

3. After loading, apply the parking brake and remove the engine switch key.
4. Tie the tractor down securely.

Tie-down hooks should be on or near the floor. Use the tie-down points shown below.

NOTICE

- Use heavy-duty restraints such as chains, or cables to fasten tractor to the trailer. Both front and rear restraints must be directed down and outward from tractor.
- To avoid damaging the tie rods, be careful not to put the restraints around or near them when securing the front end.

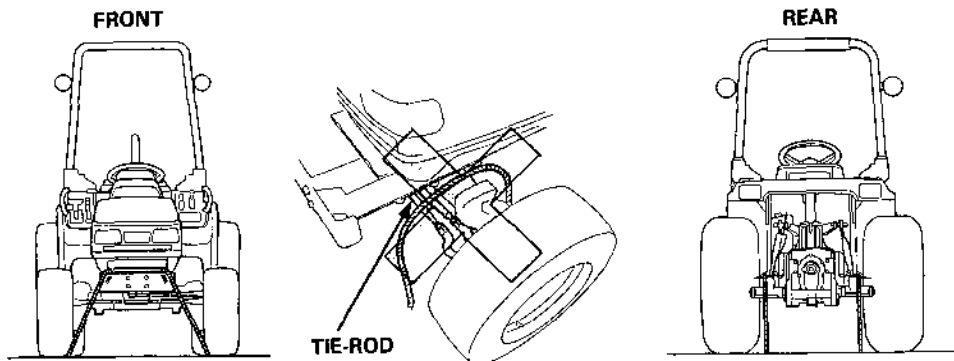

8. INSTALLING AN ATTACHMENT

Before installing or using any attachment, carefully read all instructions and precautions.

⚠ WARNING To prevent accidental start-up, remove the engine switch key, before installing or adjusting attachments.

1. Rear 3-point hitch link installation (option)

- 1. Set the stab bolt on the check link, and install the check link on the right and left lower links using the 12 mm nuts and 12 mm spring washers.
- 2. Install the right lift rod (i. e. lift rod equipped with the turnbuckle) on the right lower arm, and install the left lift rod on the left lower arm. Secure the lift rods using the lower link pins and lock pins.
- 3. Install the right and left lower links on the tractor and secure them with the linchpins.

NOTE: When the tractor is equipped with the cutter housing, install the lower links with the cutter housing lift link mounted on the tractor, and install the lift link chain using the lift link pin and linchpin as shown in Fig 1.

- 4. Set the other end of the check link installed on the lower link in the step – 1 in the joint stab, and secure it with the lift arm pin and snap pin.
- 5. Install one end of the top link (i. e. the side where the adjusting nut is not mounted) on the top link bracket of the tractor, and secure it with the linchpin.
- 6. Attach the end of the right and left lift rods to the lift rod pin and secure them with the linchpin.
- 7. Check that all parts are installed securely.

Insert the linchpin downward through the hole, then flip the retaining ring down.

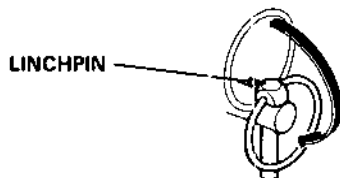

When the tractor is transported without attaching the attachment to the 3P-hitch, be sure to install the stopper spring on the lower arms.



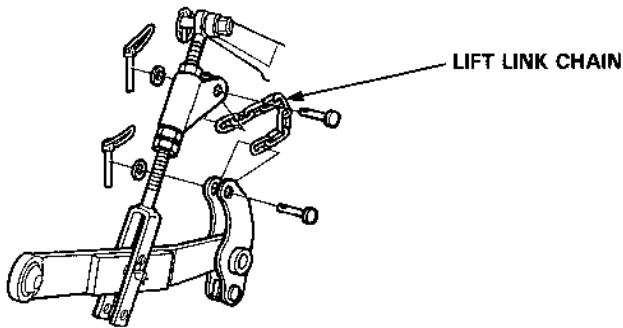
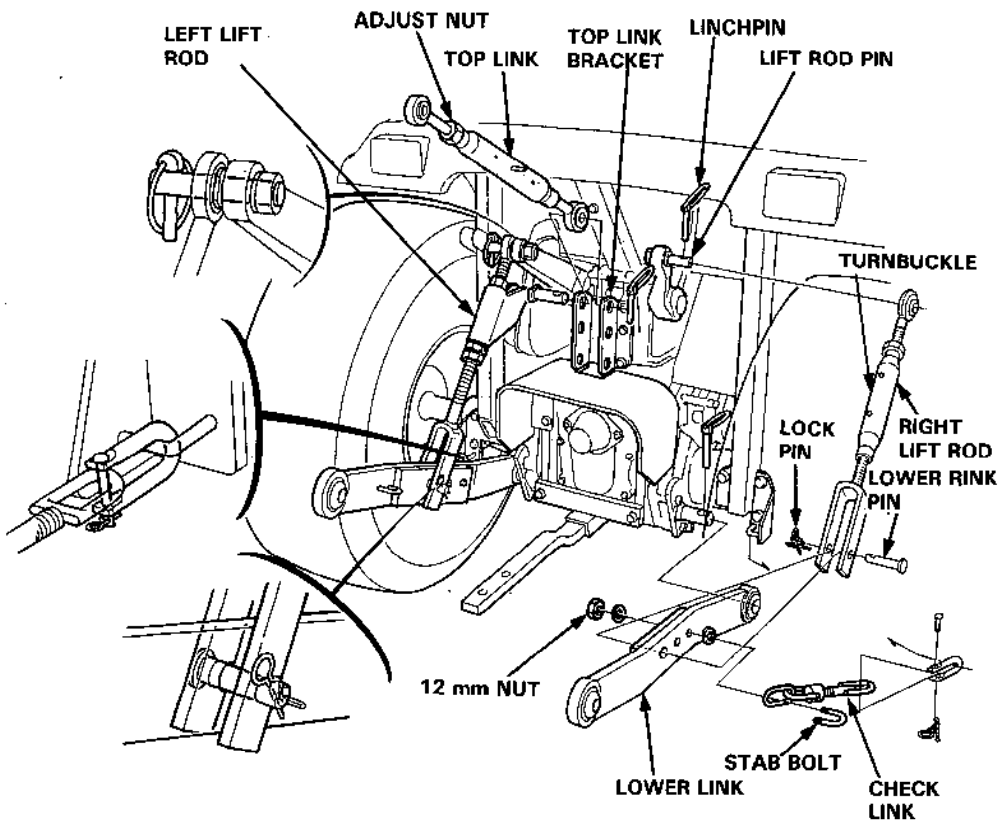

Fig 1



2. Rear 3-point hitch attachment installation

Park the tractor on firm, level ground and set the parking brake. Move the main transmission selector to N and PTO clutch lever to OFF. Remove the engine switch key.

⚠ WARNING Installing, adjusting or removal of an attachment with the engine running is dangerous and you can be injured. Remove the key from the engine switch to prevent start-up

- a. Place the lift control lever in the DOWN position and fully lower the lower links.
- b. Slacken the check links and open the lower links as necessary.

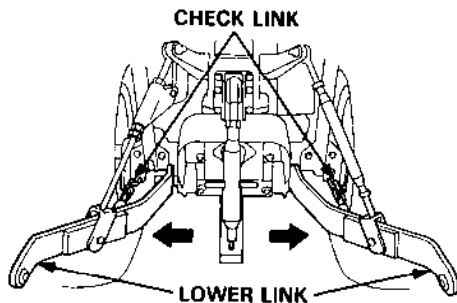

- c. Install the lower link on the left side first, then the right side using the turn buckle adjuster to adjust for length.

TURNBUCKLE ADJUSTER

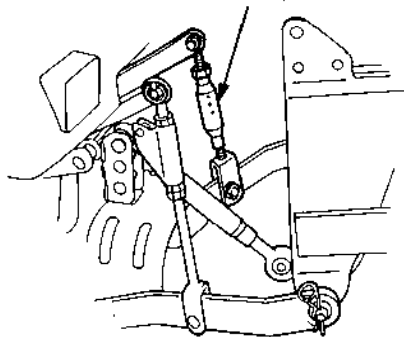

- d. Install the top link to the attachment top mast.
- e. Adjust length of the top link with the handle and secure with the lock nut.

TURNBUCKLE ADJUSTER

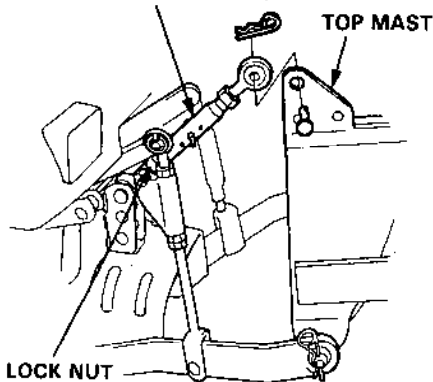

f. Install the driveline for PTO-driven attachments.

- Push and hold the lockpin and slide the driveline collar over the PTO shaft. Move the driveline collar back and forth to be sure the lockpin is seated.

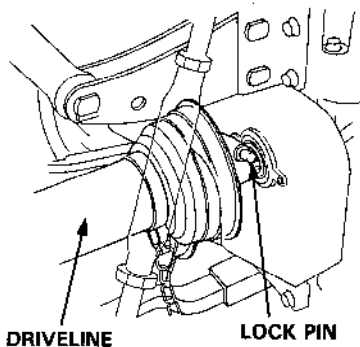

g. Use the turnbuckle adjuster on the right side of the lift rod to get the attachment horizontal. After adjusting, secure with a lock nut.

h. Adjust the check link as instructed in the attachment manual, and obtain the adequate free play in the right and left directions.

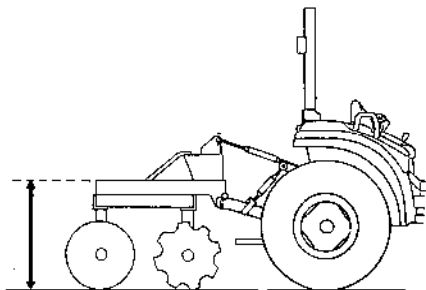
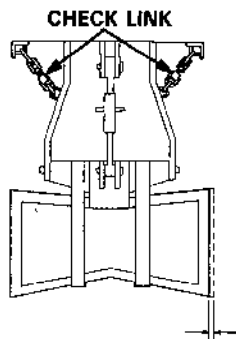

NOTICE

- After installing an attachment, be sure all lock pins are secure.
- When operated at sharp angles, a PTO driveline can make noise. Adjust the top link or limit upward travel to reduce the angle. Continued operation of a PTO driveline at sharp angles will cause damage to the driveline, attachment, or tractor.
- Be sure there is some freeplay in the check links. If they are adjusted too tightly, they may break.
- Use only attachments that meet Category 1 specifications.

9. MAINTENANCE

Periodic maintenance and adjustment are necessary to keep the tractor in good operating condition. Service and inspect according to the MAINTENANCE SCHEDULE.

▲ WARNING

- To avoid carbon monoxide poisoning, shut off the engine before performing any maintenance. If you run the engine in an area that is confined, or even partially enclosed, the air you breathe will contain a dangerous amount of exhaust gas. If the engine must be run for any reason, be sure the area is well-ventilated.
- To avoid serious burns, allow the engine to cool before performing maintenance.
- Shut the engine off and set the parking brake before performing any maintenance.
- To prevent accidental start-up, remove the engine switch key.
- The tractor should be serviced by an authorized Honda compact tractor dealer unless the owner has proper tools and service data and is mechanically qualified.

NOTICE

Use only genuine Honda parts or their equivalent for maintenance or repair. Replacement parts which are not of equivalent quality may damage your tractor.

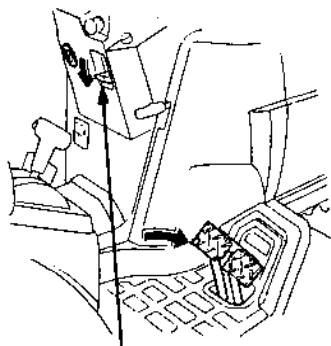

PARKING BRAKE LOCK

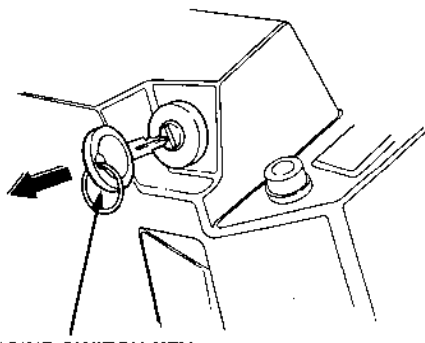

ENGINE SWITCH KEY

1. Tool kit

The tools supplied are necessary for performing some periodic maintenance, simple adjustments and repairs.

The tool kit is stored in the tool bag under the seat.

The tool kit as well as the Owner's Manual should always remain with the tractor.

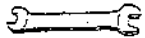

8 x 12 OPEN END WRENCH



SPARE FUSE
(5A, 10A)



10 x 12 OPEN END WRENCH

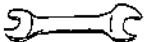

10 x 14 OPEN END WRENCH



17 x 19 OPEN END WRENCH

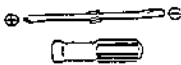

No. 2 SCREWDRIVER
SCREWDRIVER GRIP



PLIERS



TOOL BAG



14 x 17 EYE WRENCH

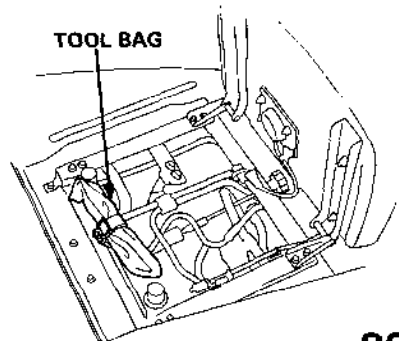
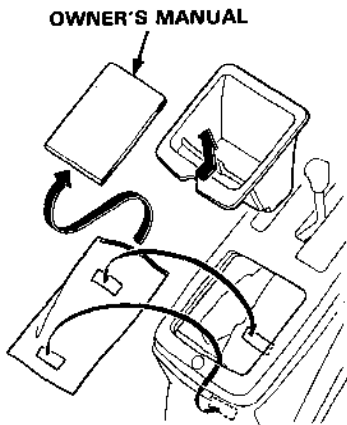

2. Maintenance schedule

REGULAR SERVICE PERIOD (3)		EACH USE	FIRST 50 HRS	EVERY 50 HRS	EVERY 100 HRS	EVERY 300 HRS	EVERY 500 HRS
ITEM							
Engine oil	Check level Change	○	○		○		
Battery electrolyte	Check level	○					
Air cleaner	Check-Clean Change		○ (1)	○ (1)			○ (1)
Radiator screen	Clean	○					
Battery under tray	Clean	○					
Radiator coolant	Check Change	○	Every 2 years (2)				
Radiator Core	Check-Clean				○		
Fuel strainer cup (inc filter)	Check Clean	○			○		
Inter lock system operation • Seat switch • Brake switch • Parking brake switch • P.T.O. select switch • P.T.O. clutch switch • Neutral switch	Check	○					
Transmission oil	Check Change		○ ○ (2)	○		○ (2)	
Power steering oil	Check level		○	○			
Parking brake operation	Check	○					
Tires: nuts and bolts tightness Air pressuer, cracks, damage, etc.	Check-tighten Check	○ (4) ○	○	○			
Steering wheel free play or looseness	Check	○					
Headlight	Check	○					
Hazard Lamp	Check	○					
Clutch pedal free play	Check Adjust	○				○ (2)	
Brake pedal free play	Check Adjust	○				○ (2)	
Spark arrester (optional part)	Clean				○ (2)		
Fun belt	Check Adjust	○	○ (2)		○ (2)		
Power steering belt	Check Adjust	○			○ (2)		

REGULAR SERVICE PERIOD (3)		EACH USE	FIRST 50 HRS	EVERY 50 HRS	EVERY 100 HRS	EVERY 300 HRS	EVERY 500 HRS
ITEM							
Fuel filter	Change						○
Fuel pump filter	Change						○ (2)
Engine oil filter	Change	Every 200 HRS (2)					
Transmission oil filter	Change		○ (2)			○ (2)	
Front axle oil	Change		○				○
Fuel line	Check (Replace if necessary)	Every 2 years (2)					
Fuel tank	Clean						○ (2)
All fasteners (for tightness)	Check-Retighten			○			
Lubrication points	Oil-Grease			○			
Tie-rods (for bending, ball-joints (for looseness) Toe-in	Check-Adjust					○ (2)	
Valve clearance	Check-Adjust	Every 1000 HRS (2)					
Injection nozzle	Check						○ (2)

- NOTE: (1) Service the air cleaner more frequently when used in dusty areas.
(2) These items should be serviced by an authorized Honda tractor dealer, unless the owner has proper tools and is mechanically proficient. See the Honda Shop Manual.
(3) For professional commercial use, log hours of operation to determine proper maintenance intervals.
(4) Check the nuts daily for the first 50 hours of operation, and retighten if necessary.

3. Engine oil change

Engine oil is a major factor affecting engine performance and service life.

CAUTION Used motor oil may cause skin cancer if repeatedly left in contact with the skin for prolonged periods.

Although this is unlikely, unless you handle used oil on a daily basis, it is still advisable to thoroughly wash your hands with soap and water as soon as possible after handling used oil.

Oil check interval: Each use.

Oil change interval: After the first 50 hours, then every 100 hours.

Oil capacity: 2.9 l (3.1 US qt) When oil filter is not replaced.

3.5 l (3.7 US qt) When oil filter is replaced.

Engine oil replacement

Drain the oil while the engine is warm to assure rapid and complete draining.

1. Open the engine hood and prepare a suitable container.
2. Remove the oil filler cap and drain plug to drain the oil.

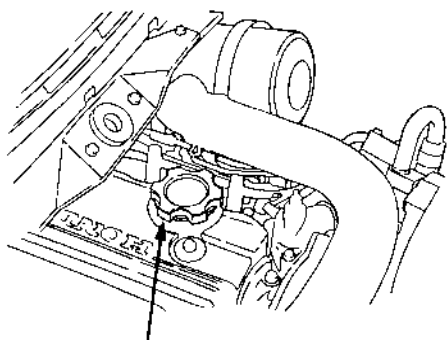

OIL FILLER CAP

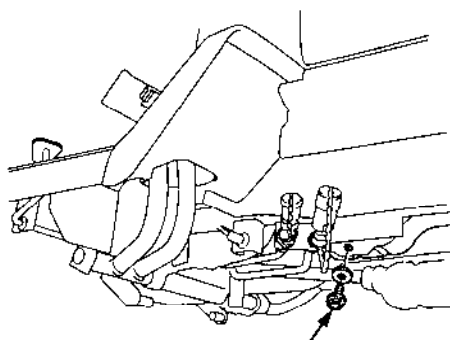

DRAIN PLUG

3. After draining is complete, check that the sealing washer is in good condition (replace if necessary), then retighten the drain bolt securely.
4. Refill with the recommended engine oil and check the oil level inserting the dipstick with the handle ring of the dipstick toward down (see page 41).
5. Install the oil filler cap securely.
6. Start the engine and allow it to warm to normal operating temperature. Stop the engine and recheck the oil level with the oil level dipstick.

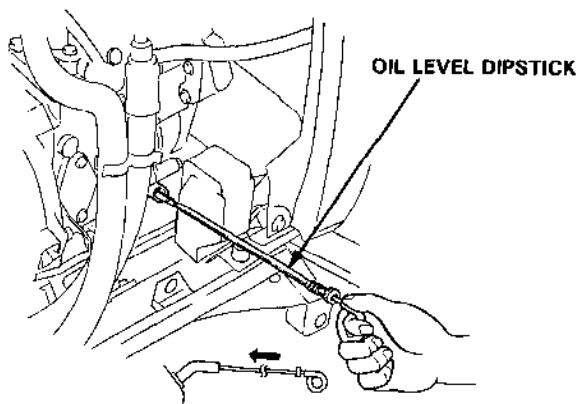

NOTE: Please dispose of used motor oil in a manner that doesn't harm our environment. We suggest you take it in a sealed container to your local oil reclamation station. Do not throw it in the trash or pour it on the ground or down a drain.

4. Air cleaner service

If you operate the tractor in very dusty areas, clean the air cleaner more often than specified in the MAINTENANCE SCHEDULE.

Operating the engine without the air cleaner will cause rapid engine wear.

Element check interval: Every 50 hours.

Element change interval: Every 500 hours.

Element cleaning

1. Open the engine hood.
2. Remove the wing nut and remove the air cleaner cover.
3. Remove the wing bolt and the air cleaner element.

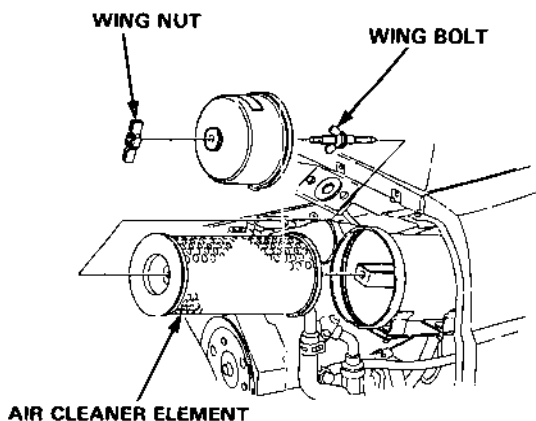

4. Clean the element by blowing compressed air from inside or tapping on it lightly.

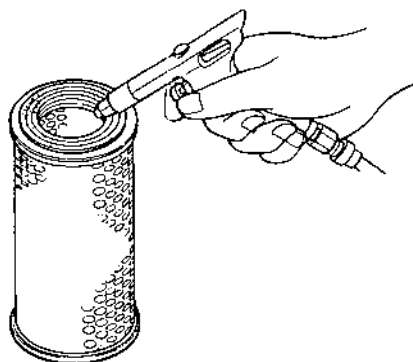

Pre-air cleaner inspection/cleaning

Inspection

Check inside of the pre-air cleaner for contamination and check the dust discharge port for clogging.

Cleaning

1. Loosen the clip and disconnect the air cleaner hose from the pre-air cleaner.
2. Remove the two bolts and remove the pre-air cleaner from the radiator shroud.
3. Remove the dust, dirt, and other foreign materials from the pre-air cleaner and fan, and wipe them clean.

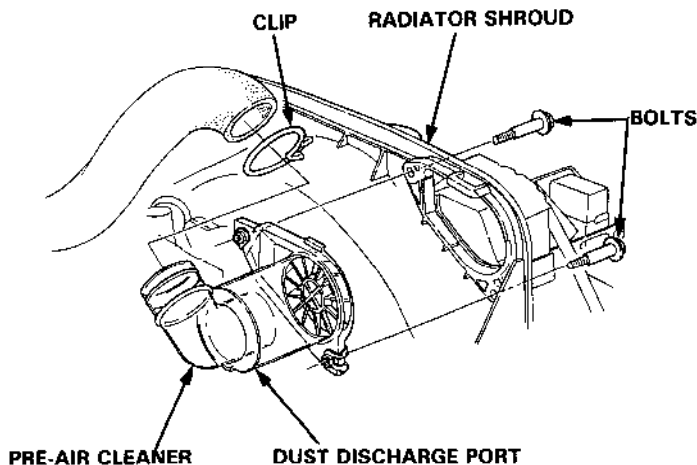

5. Transmission fluid

Contaminated transmission fluid adversely affects the service life of the sliding and the rotating parts.

Check the transmission fluid regularly and fill to the specified level.

Oil check interval: Every 50 hours

Oil change interval: After the first 50 hours, then every 300 hours

(Consult with an authorized Honda dealer for fluid change.)

Use only DEXRON® II Automatic Transmission Fluid (A.T.F.) when adding or changing fluid.

NOTICE

Use only DEXRON® II in the transmission and in implements using the tractor hydraulic system. The use of any other type of fluid will damage the transmission and hydraulic system.

Inspection

Stop the engine and wait for at least 3 minutes before inspection.

1. Detach the attachment from the tractor and push down the lift arm to the lowermost position by hand.
2. Move the seat to full forward position. Remove the dipstick and wipe it clean. Insert the dipstick into the transmission case as far as it goes and check the transmission fluid level. It should be between the upper and lower level marks on the dipstick.

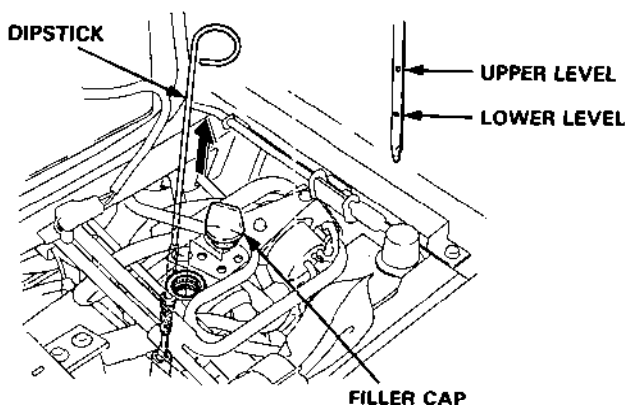

-
3. If the oil level is near or below the lower level mark, remove the filler cap and add fresh transmission fluid to the upper level mark on the dipstick.

NOTICE If the transmission fluid level dropped excessively in a short period, the hydraulic system might be faulty. Consult with an authorized Honda compact tractor dealer.

6. Power steering fluid

Check the power steering fluid level and check for leaks.

Fluid check interval: Every 50 hours

Recommended fluid: Genuine Honda Power Steering Fluid

Set the steering wheel at the straight driving position and check whether the power steering fluid level is between the upper and lower level marks on the reservoir tank.

If the level is near or at the lower level mark, remove the cap and add the fluid to the upper level mark.

After refilling, tighten the cap securely.

CAUTION

Use only genuine Honda power steering fluid. The use of other fluids such as A.T.F. or other manufacturer's power steering fluid will damage the system.

NOTICE

- If the power steering fluid level dropped excessively in a short period, the power steering system might be faulty. Consult with an authorized Honda compact tractor dealer and have your tractor checked.
- Take care not to let foreign materials enter the reservoir tank while refilling.
- The fluid level changes when you turn the steering wheel right or left with the engine stopped.

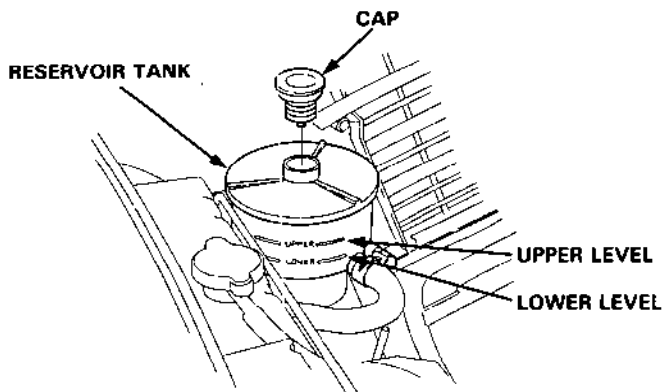

7. Front axle case oil change (A4 type only)

Oil check change interval: After the first 50 hours, then every 500 hours

Recommended oil: SAE 10W-30

Oil capacity: 3.0 ℓ (3.2 US qt)

Remove the right and left axle air bleed plugs and drain plugs to drain the oil. After draining, tighten the drain plugs securely. Pour fresh oil to the specified level through the oil filler plug and tighten the oil filler plug and air bleed plug securely.

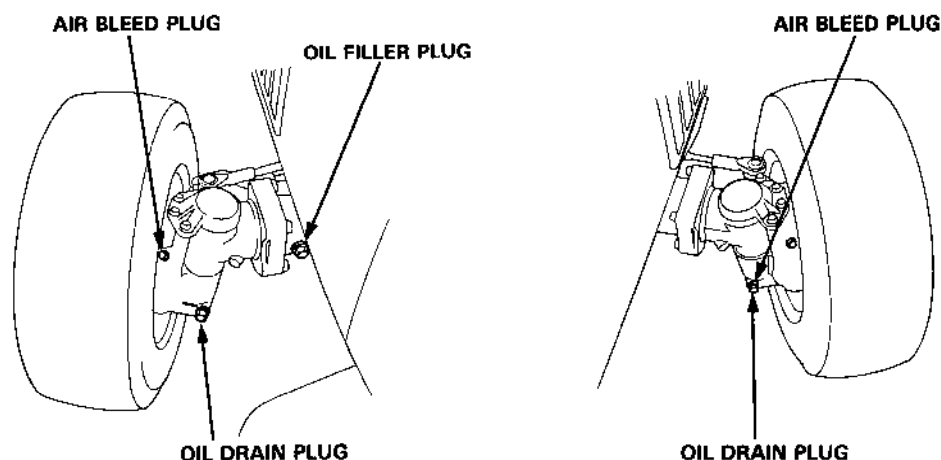

8. All fasteners tightness/lubrication points

- Check all nuts, bolts and fasteners and tighten securely if necessary.
- Check and apply grease where noted.

Recommended Grease: SAE Multipurpose Grease

Fastener tightness/lubrication interval: Every 50 hours

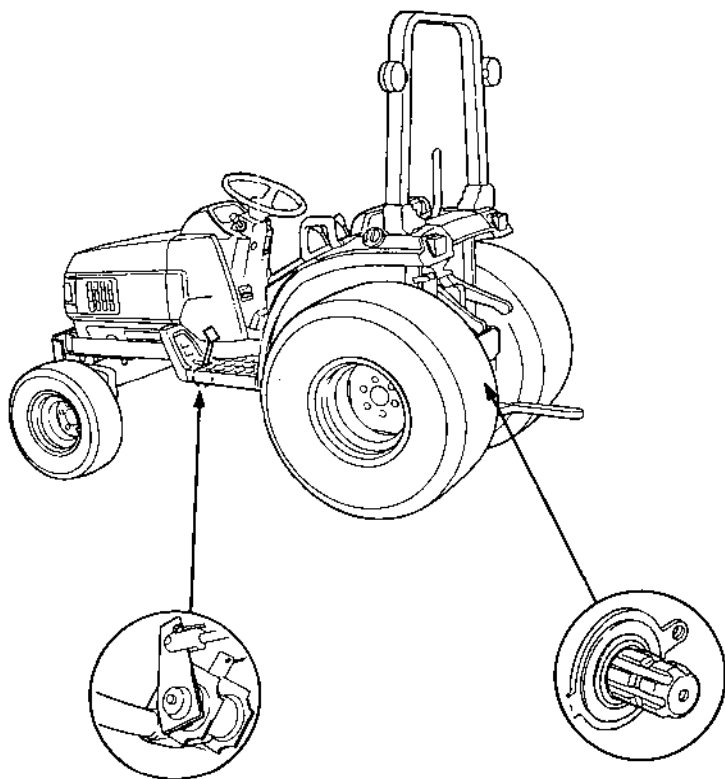

Lubrication points (cont'd)

Check and apply grease where noted.

Recommended grease: SAE Multipurpose Grease,

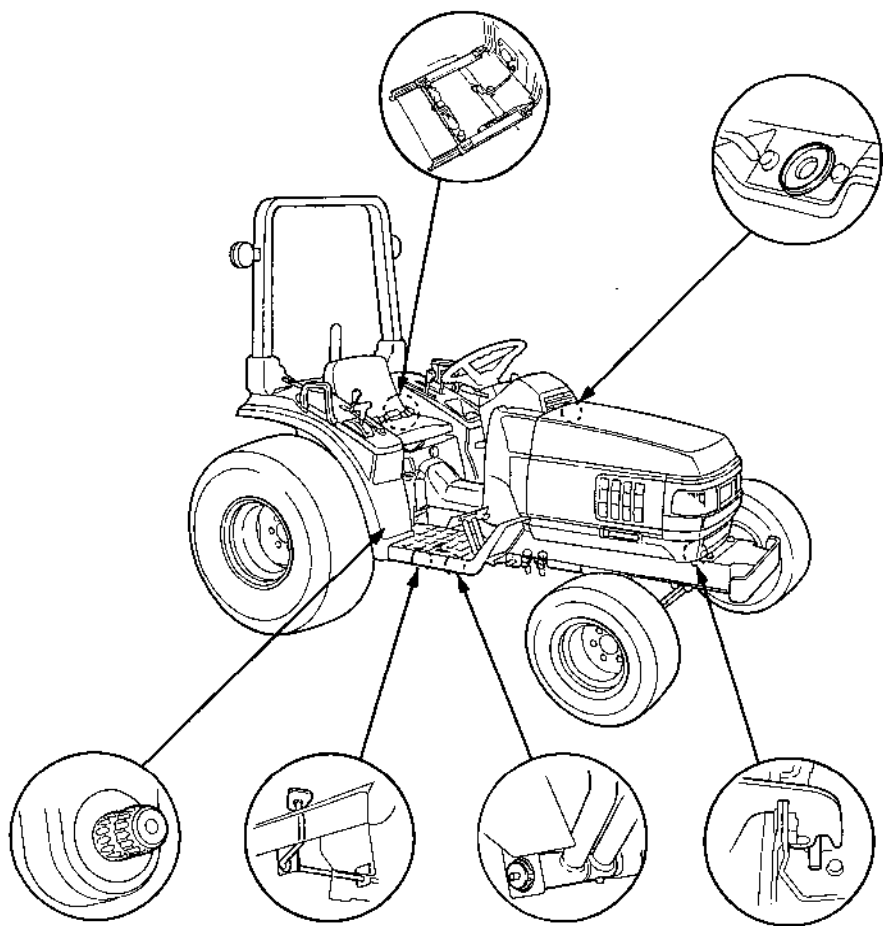

9. Fuel filter

⚠ WARNING Diesel fuel is extremely flammable and explosive under certain condition. Do not smoke or allow flames or sparks in the area.

Filter check interval: Each use

Filter cleaning interval: Every 100 hours

1. Open the engine hood and remove the left side column cover (see page 40).
 2. Turn the fuel valve to the OFF position.
 3. Loosen the ring nut and then remove the strainer cup, O-ring, spring and element.
 4. Inspect the fuel in the strainer cup for contaminants or water. Clean the strainer cup thoroughly.
 5. Install a new element using the spring, strainer cup, O-ring and ring nut. Make sure that the O-ring is in good condition and is set properly on the strainer cup.
 6. After installing the strainer cup, turn the fuel valve to the ON position.
 7. Allow fuel to reach to the strainer cup by turning the engine switch to ON.
- Check for fuel leaks. Make sure the area is dry before starting the engine.

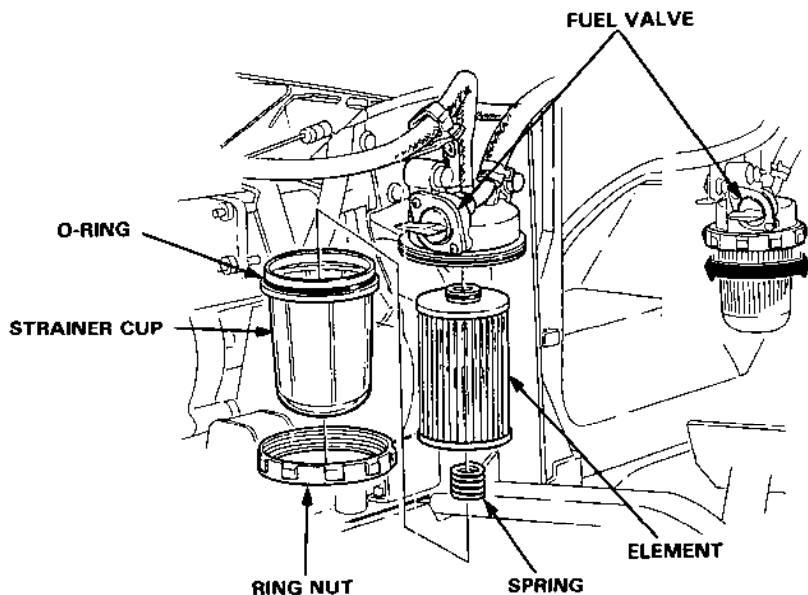

10. Radiator core cleaning

Remove any debris from radiator core.

Radiator core cleaning interval: Every 100 hours

1. Open the engine hood.
2. Remove the battery (see page 105).
3. Remove the radiator screen.
4. Remove any debris from radiator core.

RADIATOR CORE

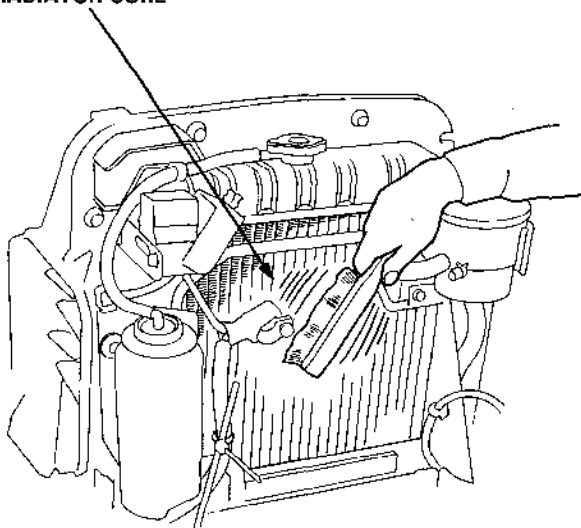

11. Battery service

■ Refilling battery fluid

If the tractor is operated with insufficient battery electrolyte, sulfation and battery plate damage will occur.

If rapid loss of electrolyte is experienced, or if your battery seems to be weak, causing slow starting or other electrical problems, see your authorized Honda compact tractor dealer.

Open the engine hood and check the electrolyte level in each battery cell. Fill the battery with distilled water to the upper level line. Never overfill the battery.

▲ DANGER

- **The battery contains corrosive sulfuric acid. Contact with eyes or skin causes burns.**

Wear protective clothing and use eye protection when working near the battery.

POISON-KEEP OUT OF REACH OF CHILDREN

EMERGENCY PROCEDURES:

- Eyes — Flush with water from a cup or other container for at least 15 minutes. Call a physician immediately.
- Skin — Remove contaminated clothing. Flush skin with large quantities of water. Call a physician.
- If swallowed — Drink water or milk and call your poison control center or a physician immediately.

- **Batteries produce explosive hydrogen gas. A spark or flame can explode the battery causing serious injury or blindness.**

Provide adequate ventilation.

Keep sparks and flames away.

Follow the above procedure carefully.

NOTE: Use distilled water in the battery.

- Tap water will shorten the service life of the battery.
- Overfilling may cause electrolyte overflow and corrosion. Wash off any spilled electrolyte immediately.

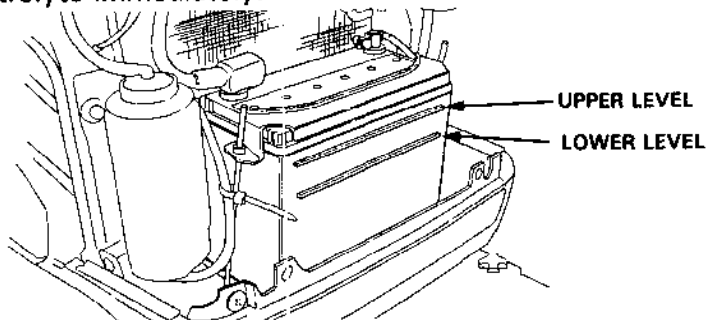

■ Battery cleaning

If the battery terminals are contaminated or corroded, remove the battery and clean the terminals.

Removal:

1. Open the engine hood and remove the hood (see page 39).
2. Remove battery hold down.
3. Disconnect the negative (-) battery cable first, then disconnect the positive (+) battery cable.
4. Remove the battery.
5. Clean the terminals with a wire brush or sand paper. Clean the battery with a solution of baking soda and warm water, taking care not to get the solution of water in the battery cells. Dry the battery thoroughly. Clean the battery cable ends with a wire brush or sand paper.

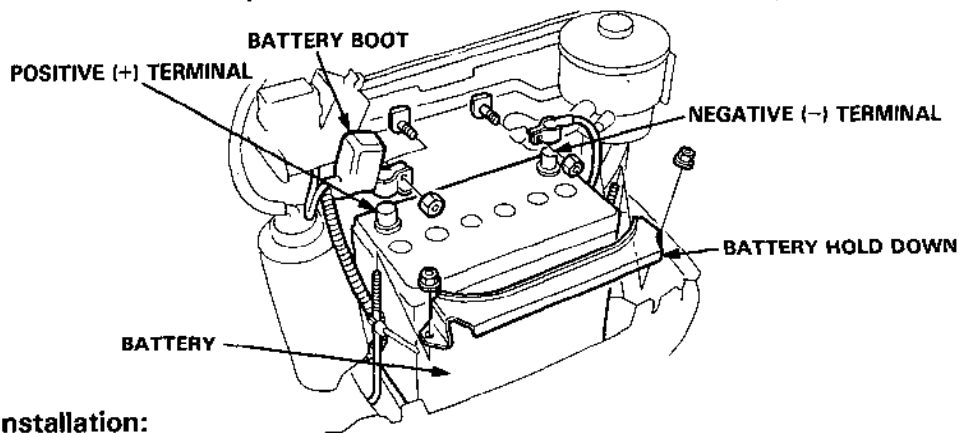

Installation:

1. Install the battery into the tractor.
2. Connect the positive (+) battery cable first and tighten the nut securely. Slide the battery boot over the positive (+) cable and terminal.
3. Connect the negative (-) battery cable. Tighten the nut securely.
4. Coat the battery terminals and cable ends with clean grease.
5. Reinstall the battery hold down.
6. Reinstall the engine hood (see page 39).

12. Wheel removal

Do not attempt to remove a wheel unless the tractor is on firm level ground.

Do not attempt to remove or replace a tire unless you have the equipment and knowledge to do so properly.

▲ WARNING Tires weighted with liquid can weigh more than 91 kg (200 lb). Use appropriate lifting and supporting equipment.

1. Set the parking brake and put the transmission in gear.
2. Block the wheels securely and loosen the lug nuts and bolts counterclockwise one turn.
3. Place a jack under the jack point nearest the wheel you are removing and raise the wheel off the ground.
4. Remove the nuts and wheel.
5. Install the wheel and hand-tighten the nuts.
6. Lower the tractor, remove the jack, and then tighten the nuts a little at a time in an "X" pattern.

Specified torque: Front wheel nut 130 kg-m (94 ft-lb)

Rear wheel nut, bolt 18.5 kg-m (134 ft-lb)

[JACK POINTS]

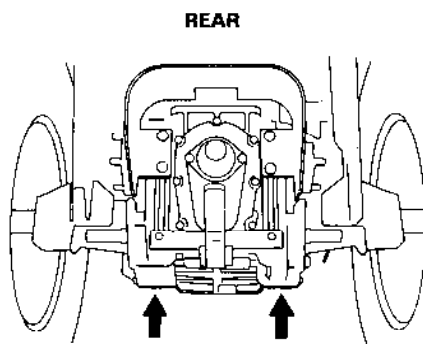
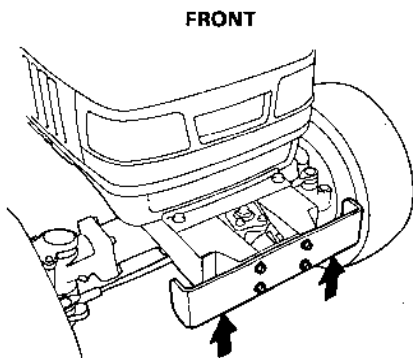

13. Fuse replacement

When frequent fuse failure occurs, it usually indicates a short circuit or an overload in the electrical system. See your authorized Honda compact tractor dealer for repair.

The main fuse panel is located ahead of the radiator on the right side. The sub-fuse panel is located under the left cowl cover above the fuel strainer.

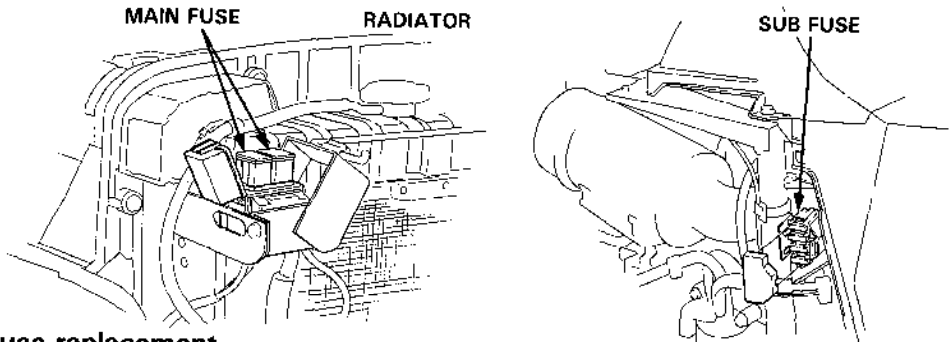

Fuse replacement

Turn the engine switch OFF and remove the key before checking or replacing fuses to prevent accidental short-circuiting.

Main fuse:

Open the lid and check for the blown out fuse.

BLOWN FUSE

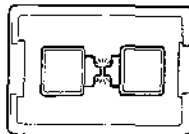

Sub fuse:

To replace subfuse pull the old fuse out of the clips with your finger. Push a new fuse into the clips.

BLOWN FUSE

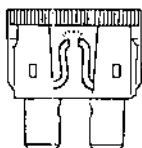

Specified rating

Main fuse: Main circuit 50 A, Glow circuit 70 A

Sub fuse: Flashing (Hazzerd) light 28 A, Warning buzzer 5 A

Relay 5A,

Headlight 15 A

Glow fuel control 5 A

NOTICE

Never use fuse with a different rating from that specified. Serious damage to the electrical system or a fire may result.

14. Bulb replacement

Headlight bulb

Open the engine hood and lift up the edge of the bulb connector rubber cover and pull it back.

Push in and turn the bulb connector counterclockwise, then remove the connector and bulb.

Install the bulb, and then align the tab on the bulb connector with the cutout in the headlight case. Turn the bulb connector clockwise while pushing it in, and then fit the rubber cover down over the connector.

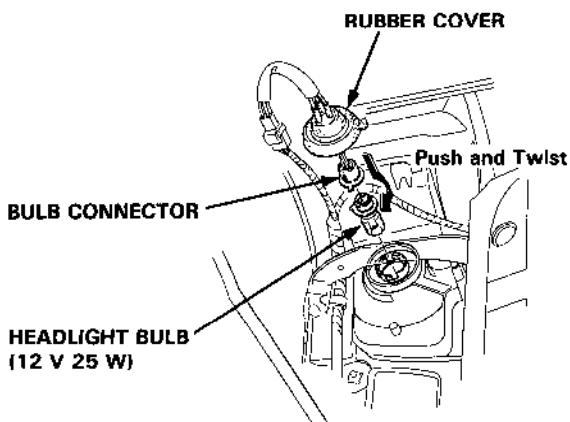

CONNER LIGHT
(12 V 5 W)

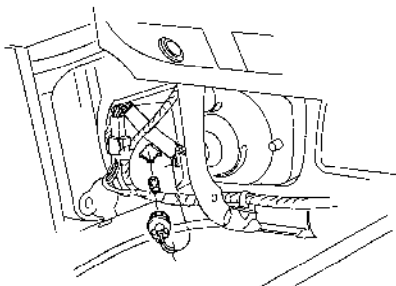

HAZZARD LIGHT
(12 V 27 W)

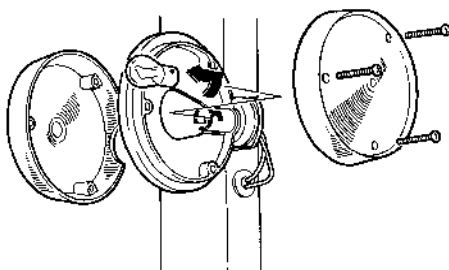

10. LONG TERM STORAGE

Storage

The engine becomes very hot during operation and remains hot for a while after stopping. Allow the engine to cool before storing.

▲ WARNING Contact with a hot engine or exhaust system can cause serious burns or fires. Let the engine cool before storing.

▲ CAUTION When storing, remove the key from the key switch to avoid unauthorized persons from operating the tractor and getting injured. To avoid the danger of exhaust fume poisoning, do not operate the engine in a closed building without proper ventilation.

When the tractor will not be operated for two or three months or longer, clean the tractor and perform the following treatment before storage.

1. Repair any parts as needed.
2. Check nuts and bolts, as necessary.
3. Apply gease or engine oil to the parts most likely to rust.
4. Inflate the tires to little above the standard pressure levels.
5. Change the engine oil and run the engine for five minutes so that the oil circuales throughout the entire lubrication system.
6. Stop the einging and remove the key.

-
7. Drain the radiator. Flush and refill with new coolant.
 8. Lower the implement to the ground.
 9. Remove the battery from the tractor, recharge it, adjust the electrolyte to the proper level, and store in a cool, dry place.
 10. The battery runs down over time even while in storage. Recharge it once a month in hot seasons and once every two months in cold seasons.
 11. Store the tractor where dry and sheltered from rain.

Removal from storage

1. Check the battery electrolyte level (see p. 104). Fully recharge the battery, and install it in the tractor.
2. Check the engine oil level (see p. 41)
3. Check the coolant level (see p. 42)
4. Check the tire pressure (see p. 39)

11. TROUBLESHOOTING

STARTER

- Starter does not work;
1. Operator not sitting in seat properly → Engine will not be started if operator's weight is off seat by means of an interlocking system.
 2. Main transmission selector set in other than NEUTRAL → Set lever in NEUTRAL
 3. P.T.O. clutch lever set in ON → Set lever in OFF
 4. Parking brake not locked or brake pedal not depressed → Set parking brake or depress brake pedal.
 5. Loose or corroded battery terminal → Retighten or clean (see p. 105)
 6. Blown fuse → Replace (see p. 107)
 7. Battery discharged → See your authorized Honda compact tractor dealer

ENGINE

- Engine cranks but won't start;
1. No fuel in tank → Refill tank (see p. 36)
- Engine lacks power;
 - Unstable engine rpm;
 - Stalling after starting;
1. Improper grade of fuel → Drain residual fuel and refill (see p. 36)
 2. Fuel filter clogged → Clean (see p. 102)
 3. Air cleaner clogged → Clean (see p. 94)
 4. Parking brake not released fully → Release fully
 5. Brake dragging → See your authorized Honda compact tractor dealer
 6. Excessive load → Reduce load or speed

When the engine is overheated

Park the tractor in a safe place.

Allow the engine to cool by running it at idle with the engine hood opened.

Stop the engine after the engine has cooled. Check the radiator coolant level and clean the radiator screen thoroughly.

If the needle of the temperature gauge remains/in the red zone, stop the engine immediately.

NOTICE Continuing to operate the tractor while it is overheated can lead to severe engine damage.

ELECTRICAL SYSTEM

Lights will not turn ON

- Engine switch not set in RUN position → Set engine switch in RUN position.
- Bulb blown → Replace bulb.
- Fuse blown → Replace fuse.

Battery charging lamp remains ON after starting engine

- Short or open circuit → Have tractor inspected and repaired by authorized Honda compact tractor dealer.

Low oil warning lamp remains ON after starting

- Insufficient oil in engine → Add oil to proper level.

Parking brake warning lamp remains ON and buzzer sounds during operation

- Parking brake not released → Release.

HYDRAULIC LIFT

Attachment will not raise or lower

- Lowering speed control knob —> Adjust descend speed by opening knob.
- Lift control lever left in LOWER position —> Set lever in appropriate position.
- Insufficient oil in transmission —> Raise level to proper position.

BRAKES

Pull to one side

- Uneven tire pressures —> Inflate to correct pressures
- Uneven brake pedal freeplay —> Have brakes adjusted by authorized Honda compact tractor dealer.
- Brake pedals not connected —> Connect with connecting plate.

STEERING

Sluggish or heavy steering

- Insufficient tire pressure —> Inflate to specified pressure.
- Insufficient fluid in power steering system —> Add.
- Loose power steering belt —> Check belt tension. Have belt adjusted by authorized Honda compact tractor dealer.

Excessive kickback on steering wheel

- Uneven tire pressure —> Inflate to specified pressure
- Incorrect toe-in —> Have adjustment checked by authorized Honda compact tractor dealer.
- Incorrect tractor balance —> Be sure 20% of tractor weight is on front wheels.

CLUTCH

Clutch clipping

- Improper clutch pedal freeplay —> Have clutch inspected and adjusted by authorized Honda compact tractor dealer.

12. SPECIFICATIONS

MODEL	H6522		
Description cord	TZAD		
Type	A4, A2		
Tire	TURF	HI-FLOAT	AG
DIMENSION			
Overall length	- 2,592 mm (102.0 in)		
Overall width	1,330 mm (52.4 in)	1,295 mm (51.0 in)	1,245 mm (49.0 in)
Overall height-A2	1,876 mm (73.9 in)		
-A4	2,116 mm (83.3 in)		
Wheelbase	1,590 mm (62.6 in)		
Wheel tread (Front)	995 mm (39.2 in)		
(Rear)	985 mm (38.8 in)		
Ground clearance	255 mm (10.0 in)		
Weight			
2WD-A2	746 kg (1,645 lbs)	740 kg (1,631 lbs)	738 kg (1,627 lbs)
4WD-A4	777 kg (1,713 lbs)	771 kg (1,700 lbs)	769 kg (1,695 lbs)
ENGINE			
Model	GD1250		
Type	water cooled 4-stroke 3 cylinder diesel		
Displacement	1,235 cm ² (75.4 cu in)		
Bore and stroke	82 x 78 mm (3.2 x 3.1 in)		
Maximum horsepower	22 ps/2,600 r.p.m.		
Engine oil capacity	3.5 ℓ (3.7 US qt)		
Coolant capacity	4.4 ℓ (4.6 US qt)		
FRAME			
Brakes	Mechanical, wet, multi-plate type		
Tire Front size	23 x 8.50-12 NHS (4PR)	6-12 (4PR)	
pressure	1.55 kg/cm ² (22 psi)	1.12 kg/cm ² (16 psi)	2.11 kg/cm ² (30 psi)
Rear size	33 x 12.50-15NHS (4PR)	12.5L-15 (6PR)	9.5-16 (4PR)
pressure	1.41 kg/cm ² (20 psi)	1.97 kg/cm ² (28 psi)	1.41 kg/cm ² (20 psi)
Steering	Integral ball-and-nut power assisted type		
Fuel tank capacity	17 ℓ (4.5 US gal)		
DRIVE TRAIN			
Transmission type	Selective sliding, 9 speeds forward and 3 speeds reverse transmission power shift		
Main transmission	Selective sliding, constantmesh type		
Auxiliary transmission			

* 2WD: 2-wheel drive 4WD: 4-wheel drive

Travel speeds	MT	AT	TURF Tire	HI-FLOAT Tire	AG Tire
MT: Main transmission AT: Auxiliary transmission	1	L (1)	1.43 km/h (0.89 mile)	1.38 km/h (0.86 mile)	1.42 km/h (0.88 mile)
	2		1.99 km/h (1.24 mile)	1.92 km/h (1.19 mile)	1.97 km/h (1.22 mile)
	3		2.78 km/h (1.72 mile)	2.69 km/h (1.67 mile)	2.77 km/h (1.72 mile)
Reverse	1	M (2)	3.45 km/h (2.14 mile)	3.33 km/h (2.07 mile)	3.43 km/h (2.13 mile)
	2		4.79 km/h (2.98 mile)	4.63 km/h (2.88 mile)	4.77 km/h (2.96 mile)
	3		6.72 km/h (4.18 mile)	6.49 km/h (4.03 mile)	6.68 km/h (4.15 mile)
	1	H (3)	7.92 km/h (4.92 mile)	7.65 km/h (4.75 mile)	7.87 km/h (4.89 mile)
	2		11.00 km/h (6.84 mile)	10.62 km/h (6.60 mile)	10.93 km/h (6.79 mile)
	3		15.41 km/h (9.57 mile) (MAX)	14.89 km/h (9.25 mile) (MAX)	15.32 km/h (9.52 mile) (MAX)
Reverse	R	L	1.04 km/h (0.65 mile)	1.00 km/h (0.62 mile)	1.03 km/h (0.64 mile)
		M	2.50 km/h (1.55 mile)	2.42 km/h (1.50 mile)	2.49 km/h (1.55 mile)
		H	5.74 km/h (3.57 mile) (MAX)	5.54 km/h (3.44 mile) (MAX)	5.70 km/h (3.54 mile) (MAX)
Transmission oil capacity			13.0 f (13.7 US qt)		
Front differential oil capacity			3.2 f (3.4 US qt)		
HYDRAULIC SYSTEM					
Working pressure			15.7 MPa (160 kgf/cm ² , 2,275 psi)		
Pump type			Gear pump		
Oil Capacity			13.0 f (13.7 US qt)		
P.T.O.					
Type	Rear	Independent			
	Mid	Live independent			
Shaft	Rear	ASAE Type 1			
	Mid	INV. spline 1 inch 15 teeth (male)			
Speed	Rear	540 rpm at engine speed of 2,450 rpm			
		574 rpm at engine speed of 2,600 rpm			
		2,000 rpm at engine speed of 2,485 rpm			
	Mid	2,093 rpm at engine speed of 2,600 rpm			
ELECTRICAL					
Battery			12V 47 AH		

NOTE: Travel speed refers to the speed when the engine runs at the rated speed (2,600 rpm) under no load. Maximum speed in [] refer to the speed when the engine runs at 2,800 rpm.

Owner Satisfaction

Your satisfaction and goodwill are important to your dealer and to us. All Honda warranty details are explained in the Distributor's Limited Warranty. Normally, any problems concerning the product will be handled by your dealer's service department. If you have a warranty problem that has not been handled to your satisfaction, we suggest you take the following action:

- Discuss your problem with a member of dealership management. Often complaints can be quickly resolved at that level. If the problem has already been reviewed with the Service Manager, contact the owner of the dealership or the General Manager.
- If your problem still has not been resolved to your satisfaction, contact the Power Equipment Division of American Honda Motor Co., Inc.

American Honda Motor Co., Inc.
Power Equipment Customer Service Department
P.O. Box 100021
Duluth, Georgia 30136-9421
Telephone: (404) 497-6400

We will need the following information in order to assist you:

- Your name, address, and telephone number
- Product model and serial number
- Date of Purchase
- Dealer name and address
- Nature of problem

After reviewing all the facts involved, you will be advised of what action can be taken. Please bear in mind that your problem will likely be resolved at the dealership, using the dealer's facilities, equipment, and personnel, so it is very important that your initial contact be with the dealer.

Your purchase of a Honda product is greatly appreciated by both your dealer and American Honda Motor Co., Inc. We want to assist you in every way possible to assure your complete satisfaction with your purchase.

MEMO

MEMO

MEMO

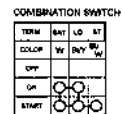
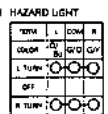
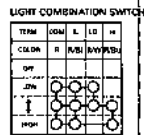
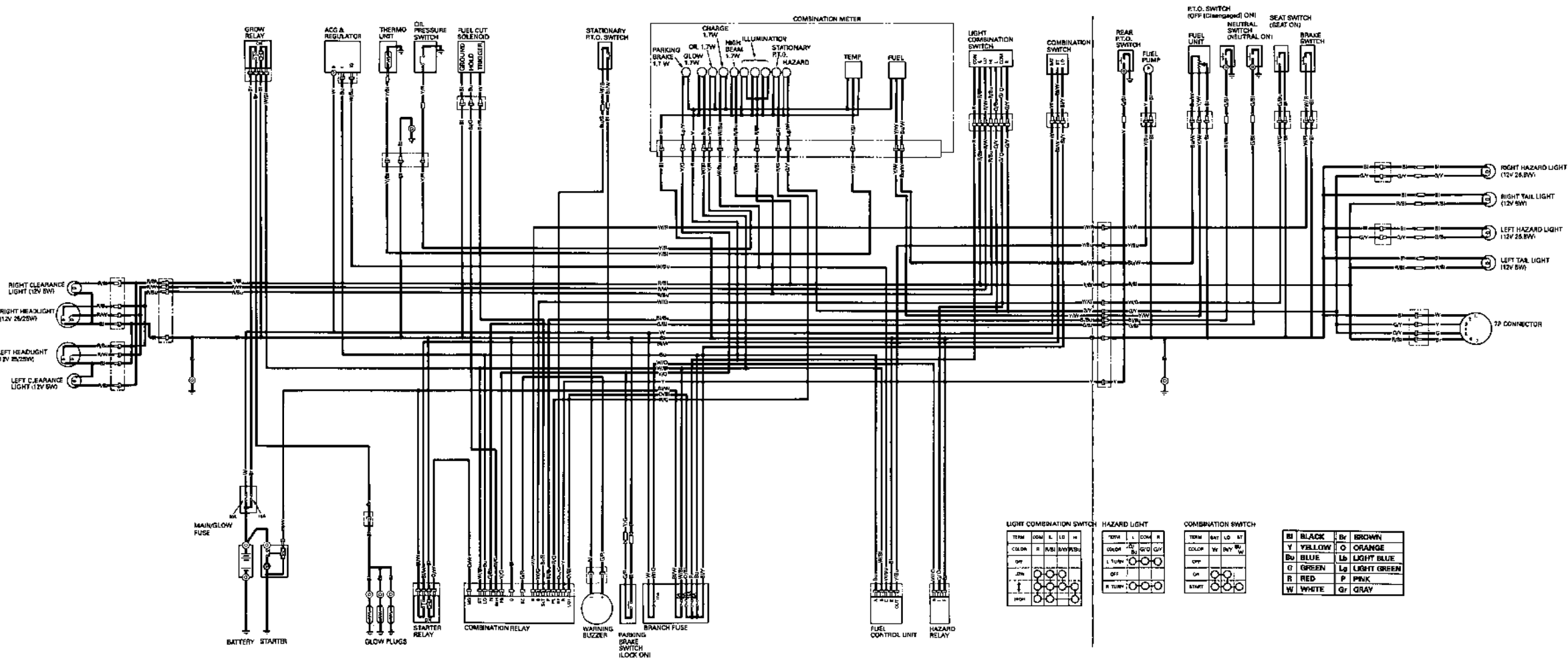

B	BLACK	Br	BROWN
Y	YELLOW	O	ORANGE
Bu	BLUE	Lb	LIGHT BLUE
G	GREEN	Lg	LIGHT GREEN
R	RED	P	PINK
W	WHITE	Gr	GRAY

HONDA
HONDA MOTOR CO., LTD. TOKYO, JAPAN

31764600
00X31-764-6001

Ⓐ Ⓑ Ⓒ 6009106
PRINTED IN JAPAN