

HONDA

Power

Equipment

OPERATOR'S MANUAL

**Front Loader
Model FL5540KO
for Honda H5518A4
Multi-purpose Tractor**

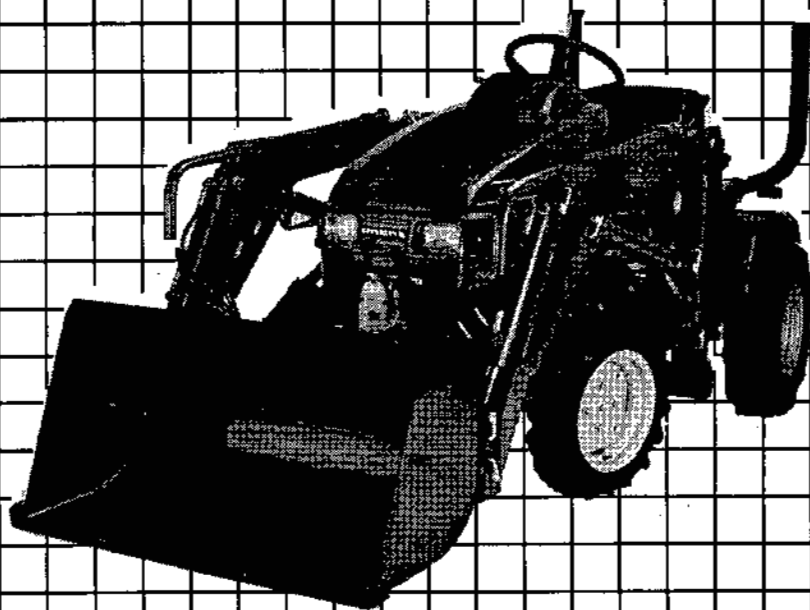

POP50387-A

2009610

Printed in U.S.A.

Thank you for purchasing an HTA Front Loader attachment for your tractor.

This manual covers the assembly, operation and maintenance of the HTA FL5540 front loader for the H5518 A4 Multi-purpose Tractor. For your convenience, it also provides a parts guide, troubleshooting section and warranty service information.

Read this manual and the owner's manual for the Honda H5518 A4 Multi-purpose Tractor before you operate the front loader.

NOTE: The information in this publication is based on the latest product information available at the time of printing. American Honda Motor Co., Inc. reserves the right to make changes at any time without notice and without incurring any obligation.

No part of this publication may be reproduced without written permission.

This manual should be considered a permanent part of the front loader and should remain with it if resold.

Safety Messages

Your safety and the safety of others are very important. We have provided important safety messages in this manual and on the front loader. Please read these messages carefully.

A safety message alerts you to potential hazards that could hurt you or others. Each safety message is preceded by a safety alert symbol and one of three words: DANGER, WARNING, CAUTION.

These words mean:

⚠ DANGER

You WILL be KILLED or SERIOUSLY HURT if you don't follow instructions.

⚠ WARNING

You CAN be KILLED or SERIOUSLY HURT if you don't follow instructions.

⚠ CAUTION

You CAN be HURT if you don't follow instructions

Each message tells you what the hazard is, what can happen, and what you can do to avoid or reduce injury.

Damage Prevention Messages.

You will also see other important messages that are preceded by the word NOTICE.

This word means:

NOTICE

Your equipment or other property can be damaged if you don't follow instructions.

Using this product for a purpose not intended can cause injury or property damage. Read and understand this Operator's Manual before operating the front loader; failure to do so could result in personal injury or equipment damage.

If a problem should arise, or if you have any questions about your front loader, consult an authorized Honda Multi-purpose Tractor dealer.

CONTENTS

TOPIC	PAGE
1.GENERAL	1
2. INTRODUCTION	3
Front loader safety	4
Maintenance safety	7
Safety label locations	8
3. PACKAGING INVENTORY	9
4. TRACTOR PREPARATION	10
5. LOADER SPECIFICATIONS	11
6. ASSEMBLY INFORMATION	12
Sub-frame installation/removal	13
Front loader assembly	19
Operational checks	25
7. OPERATING INSTRUCTIONS	27
8. LOADER REMOVAL	31
Storage	35
9. LOADER INSTALLATION	37
10. TROUBLESHOOTING	41
11. LUBRICATION and MAINTENANCE	43
Lubrication and maintenance chart	44
12. PARTS	45
13. WARRANTY SERVICE	51

INTRODUCTION

The purpose of this manual is to instruct you in maintaining and operating your HTA Front Loader. Read it carefully; it furnishes information and instructions that will help you achieve years of dependable performance. Some information may be general in nature due to unknown and varying conditions. However, through experience and these instructions, you should be able to develop operating procedures suitable to your particular situation.

"Right" and "Left" as used throughout this manual are determined by facing the direction the machine will travel when in use.

The illustrations and data used in this manual are current at time of printing, but due to possible in-line production changes, your machine may vary slightly in detail. Extra equipment that may be shown on the machine is optional at extra cost. The manufacturer reserves the right to redesign and change the machine as may be necessary without notification.

NOTE: Illustrations used in this manual may not show all safety equipment that is recommended to ensure safe operation of tractor/loader. Refer to Safety Section of this manual and the Tractor Owner's Manual for information concerning safety equipment. Consult your dealer for further information.

SERIAL NUMBER and LOCATION

The serial number is important information about the machine, and it may be necessary to know it before obtaining the correct replacement parts. The serial number is located on the right side mast as shown.

REPLACEMENT PARTS

Use only Genuine Honda Replacement parts to repair this machine. Honda replacement parts are available from your Honda Multi-purpose Tractor Dealer. To obtain prompt, efficient service, always remember to give the dealer the following information:

- Correct part description or part number.
- Model number of your machine.
- Serial number of your machine.

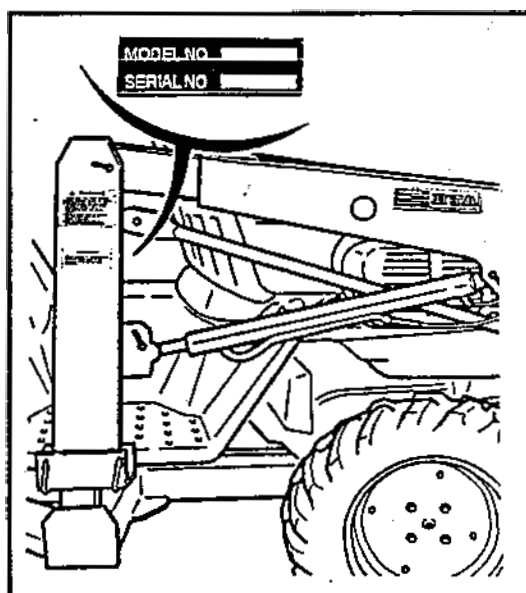

FRONT LOADER SAFETY

Operating the tractor and front loader requires special efforts on your part to ensure your safety and the safety of others. Know these requirements before you operate the tractor or front loader.

SAFE OPERATING RULES

- Severe personal injury or equipment damage may result if the operating instructions on (pages 25 thru 30) are not followed.
- Always make pre-operation checks (page 25) before you start the engine. You may prevent an accident or equipment damage.
- To avoid severe personal injury or equipment damage, observe the following precautions.
 - All parts, especially guards and shields, should be in good condition, and securely fastened in place.
 - Be sure all nuts, bolts and screws are tight.
 - Do not remove any guards, warning labels, shields or safety devices; they are installed for your safety.
 - The tractor roll over protective structure (ROPS) will only protect you from injury if;
 - you are also wearing the seat belt.
 - the ROPS is securely attached and has not been modified or structurally damaged.
- Know how to stop the engine quickly. Thoroughly understand operation of all controls.
- Never permit anyone to operate the tractor or front loader without proper instructions.
- The tractor is an operator only vehicle, do not allow passengers to ride on the tractor or front loader.
- Keep children and pets at a safe distance during operation.
- Never allow anyone to get under the front loader bucket or reach through the lift arms when the bucket is raised or tractor engine is running.
- Always wear sturdy shoes or boots and avoid wearing bulky or loose clothing while operating the tractor or the front loader.
- Be alert. Do not operate the front loader when you are tired, ill or under the influence of alcohol or drugs.
- Work with the equipment only in daylight or good artificial light.
- Watch out for and avoid rocks, roots, holes and other objects.
- If you hit an object, stop and inspect for damage; repair any damage before you operate the equipment again.
- Replace damaged, worn or broken parts immediately.
- The exhaust contains poisonous carbon monoxide gas that can cause loss of consciousness and may lead to death, if the front loader is operated in an enclosed place.

- Before leaving the tractor unattended, always lower the front loader, shift the transmission to neutral, set the parking brake, stop the engine and remove the key from the ignition switch to prevent children or unauthorized persons from starting the engine.
- Prolonged exposure to loud noise can cause permanent impairment or loss of hearing. Wear a suitable protective device such as an external hearing protector (earmuffs) or ear plugs to protect against loud or otherwise objectionable noise.
- Use extreme caution when crossing a gravel drive, walkway or road. Stay alert for the hidden hazards of traffic.

BEFORE STARTING

- The use of heavy equipment and/or pulling or lifting excessive loads may adversely affect vehicle stability or control. To avoid loss of control that can result in severe personal injury:
 - Use only recommended tractor hitch attachment points.
 - Limit loads to those within tractor and front loader limitations as stated in this manual and in the tractor owner's manual.
 - Be extra careful when turning or backing up, and when on uneven terrain.
 - Use counterweights as indicated in this manual and the tractor's owner's manual.
- Before installing or using the front loader, carefully read all instructions and precautions.

OPERATION

- Be sure to fasten the seat belt whenever driving the tractor with the Roll Over Protection Structure (ROPS) attached. Use of either device (seat belt or ROPS) without the other will increase the chance of injury in a rollover.
- Adjust the seat belt so it is snug.
- Be sure that the main transmission lever is in "Neutral" and the front and rear Power Take Off (PTO) levers are in the "Off" position before starting the engine.
- Operate the tractor and the front loader at slow speeds until you become familiar with all of the operating characteristics and controls.
- Do not operate the tractor or front loader until you are sure the area in front and behind is clear of people and pets.
- Sudden stops of the tractor or front loader during operation could cause the tractor to overturn. Be especially careful during sharp turns and when front loader bucket has material in it.
- Carry the front loader arms at a low position during transport. This will enhance vehicle stability and front vision.
- Using the front loader for handling large objects such as round hay bales, logs or oil drums is not recommended. These items can easily shift or roll down the front loader arms causing equipment damage or severe personal injury,
- This tractor utilizes Four Wheel Steering (4WS). The feel of 4WS is slightly different from other tractors and will affect front loader operation. Practice use of the front loader in a wide safe area.

FRONT LOADER SAFETY

- Never operate the tractor or front loader when visibility is diminished by darkness or by bad weather; your ability to see obstacles will become impaired.
 - Avoid loose fill, rocks and holes. They may cause vehicle instability or cause the vehicle to overturn.
 - The front loader is intended for relatively flat terrain useage.
 - Avoid overhead wires and obstacles when the front loader is in the raised position. Contacting electric wires can cause electrocution.
 - Allow for the added length of the front loader attachment when making turns to prevent striking people or objects.
 - When operating the front loader on a slope, always drive up and down the face of the grade. Turning or driving across the face of the slope may cause the tractor to overturn.
 - Operate the front loader arms gradually by "feathering" the loader controls to prevent abrupt movements that could cause damage to the front loader and tractor.
 - Use added caution when working with shifting or loose loads in the loader bucket. It could cause vehicle instability or fall out of the bucket and cause personal injury.
 - To avoid loss of control or overturning, always reduce speed and exercise extreme caution when operating the front loader on sloping or uneven surfaces.
 - Operate loader controls only from the operator's seat to prevent possible severe personal injury.
 - Attempting to change gears while operating the front loader on a slope may adversely affect vehicle stability and control and severe personal injury could result.
 - Do not back down, or rapidly accelerate up a sloping surface.
 - To avoid loss of control or overturning, do not stop or turn on sloping surfaces.
 - Do not operate the front loader near the edge of a ditch or an embankment. Slipping off the edge could lead to severe personal injury or equipment damage.
 - When descending a slope, disengaging the clutch or shifting into neutral can cause loss of control that may result in severe personal injury.
 - Be sure to follow instructions below whenever applying the tractor differential lock during front loader use.
 - Do not apply the tractor differential lock while turning, use the differential lock only while driving in a straight line.
 - Never apply the differential lock on paved surfaces.
 - To avoid injury to yourself and others; before leaving the front loader unattended, ALWAYS;
 - park on level ground and lock the parking brake.
 - lower the front bucket flat to the ground.
 - disengage the front loader drive system.
 - stop the engine and remove the key.
 - If you find it necessary to park on a grade, be sure to lock the parking brake and securely block the wheels.
-

MAINTENANCE SAFETY

Maintenance of the tractor and front loader requires special efforts on your part to ensure your safety and the safety of others. Know these requirements before performing maintenance on the tractor or front loader.

- Before performing maintenance/inspections, read the instructions thoroughly.
- Before cleaning, inspecting or servicing the loader be sure to;
 - lower the front loader bucket flat to the ground.
 - move the front PTO to the off position
 - stop the engine and remove the key.
- Always wear safety glasses when servicing or replacing the front loader cylinder pins. Use a brass drift and hammer. Failure to do so could result in eye injuries from possible flying metal objects.
- Operating the front loader or the tractor with damaged, worn, or broken parts may result in severe personal injury.
- Before disconnecting any hydraulic lines, relieve all hydraulic pressure.
- Keep hands and body from pressurized lines. Use paper, or cardboard, not body parts, to check for leaks. Hydraulic oil under pressure will penetrate the skin causing serious injury.
- Make sure that all operating and service personnel know that in the event hydraulic fluid penetrates the skin, it must be surgically removed within a few hours by a doctor familiar with this form of injury, or gangrene may result.
- All nuts, bolts, and fasteners must be properly secured.
- If you must work underneath a raised loader, make sure the arms are blocked in the raised position with a safety bar. A suitable steel safety bar can be manufactured following the dimensions as illustrated below.

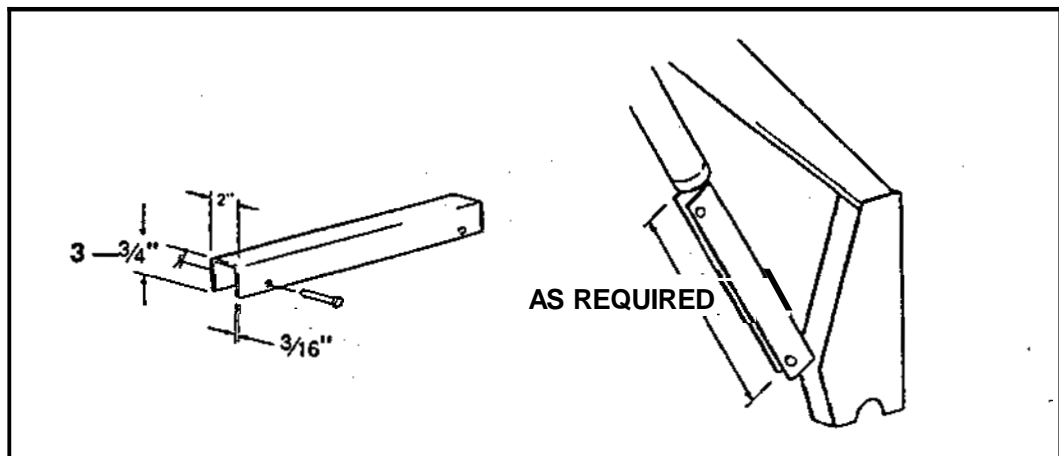

SAFETY LABEL LOCATIONS

Read these SAFETY LABELS before you operate the front loader.

WARNING

IMPROPER SERVICING CAN CAUSE SERIOUS INJURY OR DEATH

- Before servicing or adjustment lower loader to the ground and shut off engine.
- Release hydraulic pressure before disconnecting oil lines.

WARNING

TRACTOR TIP-OVER CAN CAUSE SERIOUS INJURY OR DEATH

- Add recommended wheel ballast and/or counterweights for stability.
- Drive and turn tractor at slow speed.
- Place loader low when transporting loads, especially on an incline or rough terrain.
- Put loader on ground when parked.
- Read and understand all instructions in operator's manual before operation.

NOTICE

Loader hydraulic system fluid level should be checked daily or every 10 hours of operation to prevent damage.

Loader boom must be down and bucket cylinders fully retracted when checking fluid level.

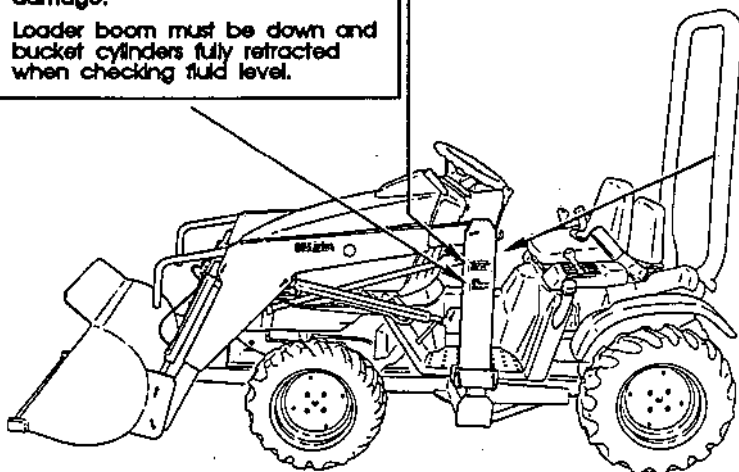

WARNING

LOADS CAN FALL FROM BUCKET CAUSING SERIOUS INJURY OR DEATH

- Improperly handling large heavy objects can cause the tractor to roll or tip over, or can cause the load to roll or slide down the loader arms onto the operator.
- Driving on uneven terrain can cause the load to tip out of bucket onto the operator or bystanders.
- Read and understand all instructions in operator's manual before operation.

INFORMATION

Special loader attachments for handling large objects are available from agricultural suppliers.

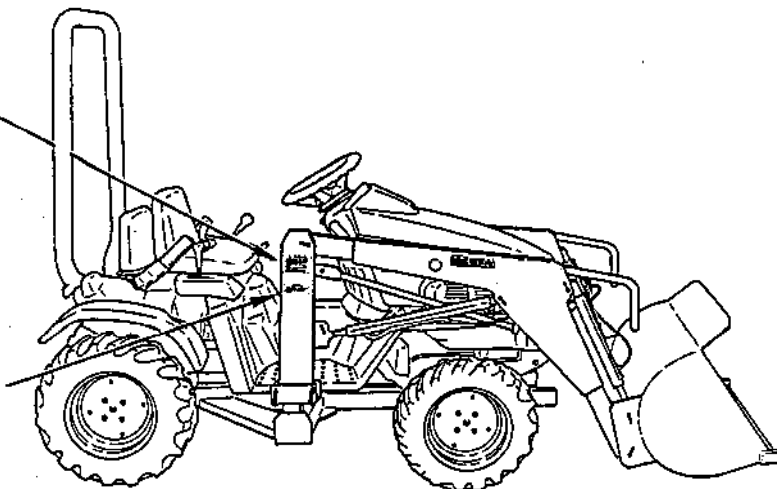

PACKAGING INVENTORY

12 Required
37.5 lbs. each

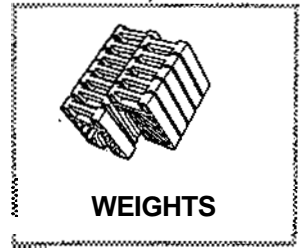
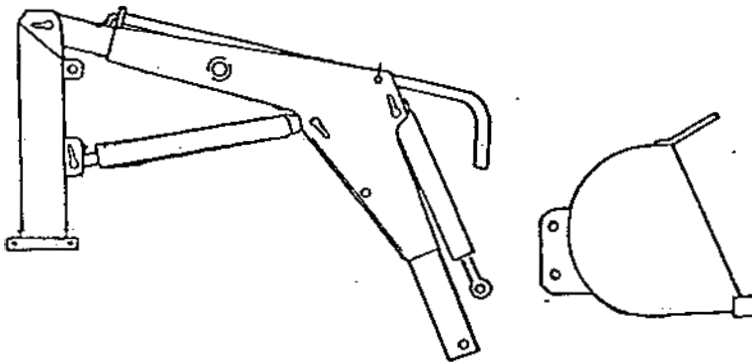

SECURED TO CRATE BOTTOM

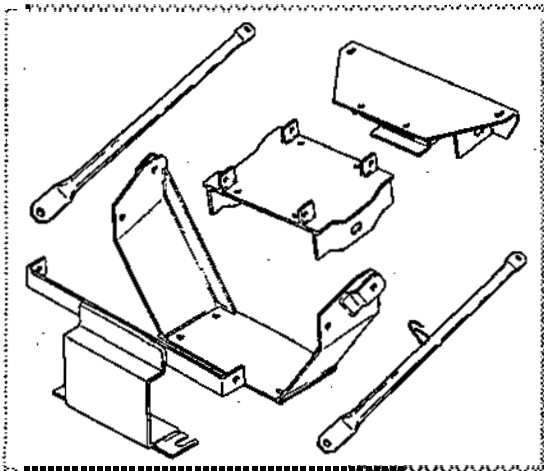
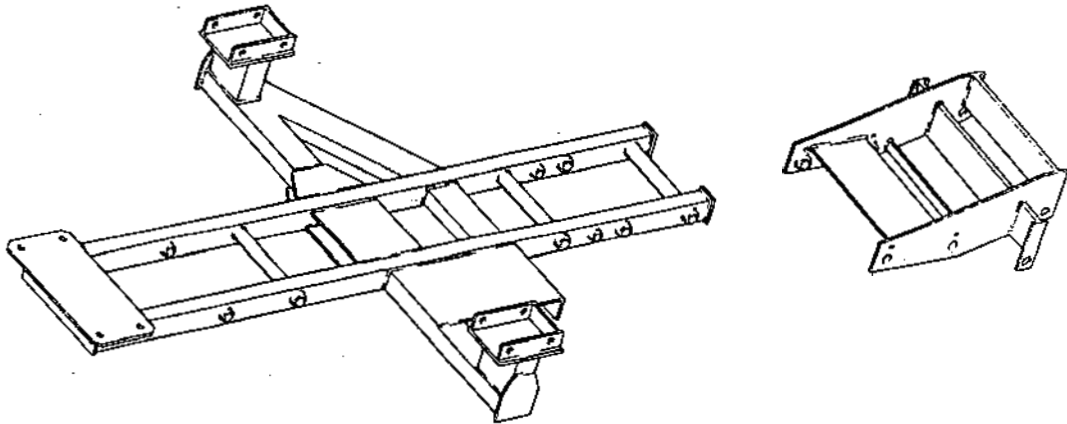

LARGE CARTON

SMALL CARTON

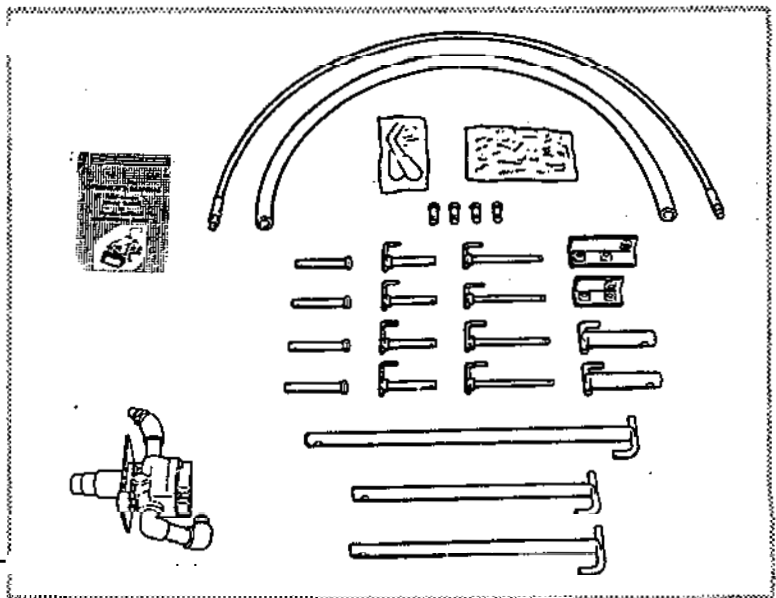

TRACTOR PREPARATION

HARDWARE BAG CONTENTS		
QNT'Y	DESCRIPTION	
		2 7/16"—14 hex nut
		2 7/16" lockwasher
		4 1/2"—13 hex nut
5	7/16" lynchpin	6 1/2" flat washer
2	10mm x 30mm hex hd capscrew	4 1/2" lock washer
2	12mm x 25mm hex hd capscrew	4 5/16"—18 x 1" hex hd capscrews
2	1/2 - 13x1 1/2" hex hd capscrew	4 5/16" lockwasher
16	#11 clip pin	2 7/16" flatwasher
12	3/4 x 1 1/4 x 10 ga. machine bushing	2 5/16"—18 13/4" hex hd capscrew
2	1/2-13x13/4" hex hd capscrew	2 5/16" flatwasher
2	3/8" flat washer	2 # 2 hose clamp
2	7/16-14x1 1/4" hex hd capscrew	1 nylon tie

TRACTOR PREPARATION

This loader is not intended to be used with any other attachments mounted on tractor.

REAR COUNTER WEIGHT

⚠ WARNING — DO NOT EXCEED THE RATING FOR MAXIMUM GROSS VEHICLE WEIGHT. REFER TO OWNER'S MANUAL PROVIDED WITH TRACTOR.

The use of adequate rear counterweight is required for proper loader stability.

Refer to Tractor Owner's Manual for specific recommendations on counterweighting tractor.

Weight added to the rear of the tractor provides better traction and easier, more efficient loader operation. The tractor must be counterweighted by installation of rear weights.

Additional counterweight requirements will vary with loader attachments and equipment applications.

⚠ CAUTION — Certain specific conditions may not permit safe use of loader at loader rating or may require more carefully restricted Operation at the rated load.

ROLL-OVER PROTECTION STRUCTURE (ROPS) SYSTEM

The tractor ROPS system must be in place and used properly to ensure adequate operator protection.

LOADER HYDRAULIC SYSTEM

Follow recommendations in this operator's manual for hydraulic fluid specifications.

TRACTOR TIRES

Selection of tires should be restricted to tire recommendations as specified by your Tractor owner's manual.

Ag tires are recommended when using the front loader

TIRE INFLATION

Front tires must be maintained at the maximum recommended inflation with the added weight of loader and material. Ag Tire pressure 34 psi.

Rear tires must be maintained at equal pressure within the recommended tire inflation range. Ag Tire pressure 24 psi.

LOADER SPECIFICATIONS

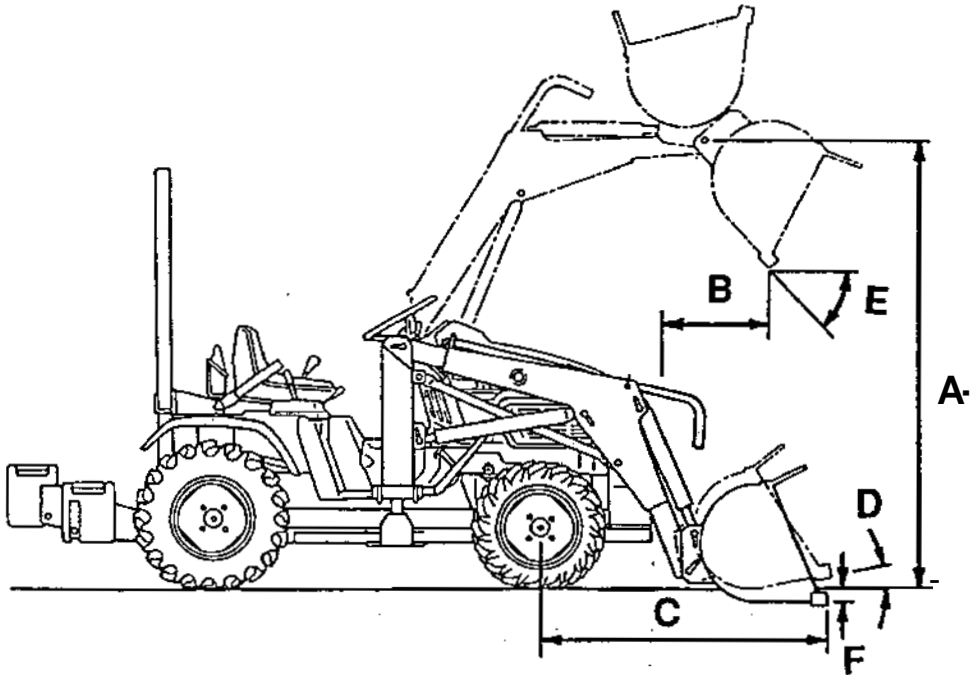

LOADER SPECIFICATIONS

ITEM	FL5540
Rated Lift Capacity	400lb (180kg)
Bucket Size (width)	42in (1050mm)
Hydraulic cylinder	Double acting
Counterweights	Suit case type 37.5lb x 12
.....	(17.0kg x 12)
Sub-frame	Frame mount type
Hydraulic Pump Drive	Front PTO coupled
Tractor Type	H5518 A4 only — Ag tires recommended
Weight w/ subframe	550lb (250kg)
Maximum Lift Height	'A' 72.1 in (1837mm)
Reach @ Maximum Height.	'B' 16.4in (409.3mm)
Reach whucket on ground	'C' 47.9in (1195.2mm)
Bucket roll back angle	'D' 17°36'
Maximum Dump angle	'E' 47°31'
Digging Depth Below Grade	'F' 3.02in (80.5mm)

ASSEMBLY INFORMATION

GENERAL

Read assembly instructions completely prior to installing loader to familiarize yourself with all mounting and hydraulic system installation procedures.

The loader operates from its self contained hydraulic system with the pump driven from the tractor front PTO.

A pipe thread sealant must be used on all pipe threads.

All hardware required for mounting loader is supplied.

Loader mount component hardware should be left loose until all mount components have been installed.

Unless otherwise specified, refer to torque specification table for torque values of hardware required for assembly.

Lay out and identify all components prior to installation.

TORQUE SPECIFICATIONS

Proper torque for American fasteners used on Honda equipment
Recommended Torque in Foot Pounds (Newton Meters). •

AMERICAN

Bolt Head Markings

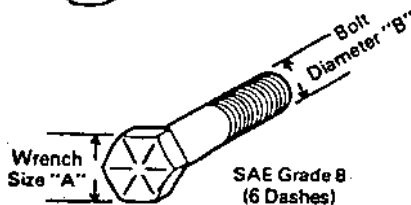
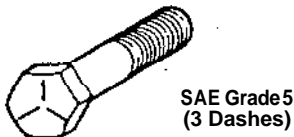

WRENCH SIZE (IN.) "A"	BOLT DIAMETER (IN.) "B" AND THREAD SIZE	SAE GRADE 2	SAE GRADE 5	SAE GRADE 8
7/16	1/4 - 20 UNC	6 (7)	8 (11)	12 (16)
7/16	1/4 - 28 UNF	6 (8)	10 (13)	14 (18)
1/2	5/16 - 18 UNC	11 (15)	17 (23)	25 (33)
1/2	5/16 - 24 UNF	13 (17)	19 (26)	27 (37)
9/16	3/8 - 16 UNC	20 (27)	31 (42)	44 (60)
9/16	3/8 - 24 UNF	23 (31)	35 (47)	49 (66)
5/8	7/16 - 14 UNC	32 (43)	49 (66)	70 (95)
5/8	7/16 - 20 UNF	36 (49)	55 (75)	78 (106)
3/4	1/2 - 13 UNC	49 (66)	76 (103)	106 (144)
3/4	1/2 - 20 UNF	55 (75)	85 (115)	120 (163)
7/8	9/16 - 12 UNC	70 (95)	109 (148)	153 (207)
7/8	9/16 - 18 UNF	79 (107)	122 (165)	172 (233)

- Use 75% of the specified torque value for plated fasteners. Use 85% of the specified torque values for lubricated fasteners;

METRIC

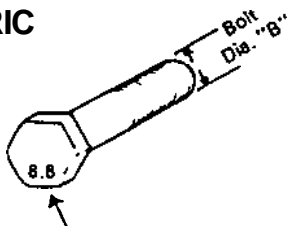

Numbers appearing on bolt heads indicate ASTM class.

Proper torque for metric fasteners used on Honda equipment.
Recommended Torque in Foot Pounds (Newton Meters). •

BOLT DIA. (mm) "B"	ASTM CLASS 4.6	ASTM CLASS 8.8	ASTY CLASS 9.8	ASTY CLASS 10.9
5	1.8 (2.4)		5.1 (6.9)	6.5 (8.8)
6	3 (4)		8.7 (12)	11.1 (15)
8	7.3 (10)		21.1 (29)	27 (37)
10	14.5 (20)		42 (57)	53 (72)
12	25 (34)	74 (100)	73 (99)	93 (126)

FL5540 SUB-FRAME and COUNTERWEIGHT INSTALLATION/REMOVAL

1. Remove the existing frame lower cover and replace with the new lower cover using existing mounting bolts and collar washers.

NOTICE — Never operate the tractor without the lower cover.

INSTALLATION INSTRUCTIONS

1. CLEAN THE CONTACT SURFACES BETWEEN BRACKET AND FRAME.
2. MOUNT THE BRACKET BY INSTALLING THE (8) BOLTS FINGER TIGHT.
3. TIGHTEN UNDERSIDE MOUNTING BOLTS: 29 ft-lbs. (39 Nm TORQUE).
4. TIGHTEN SIDE MOUNTING BOLTS: 29 ft-lbs. (39 Nm TORQUE).

NOTICE

THE TRACTOR FRAME CAN BE DAMAGED IF THE TRACTOR IS MOVED WHILE THIS COVER IS OFF OR BOLTS ARE NOT TIGHTENED TO THE PROPER TORQUE.

Note: A second label is included with this operator's manual. Install this label onto the original frame lower cover.

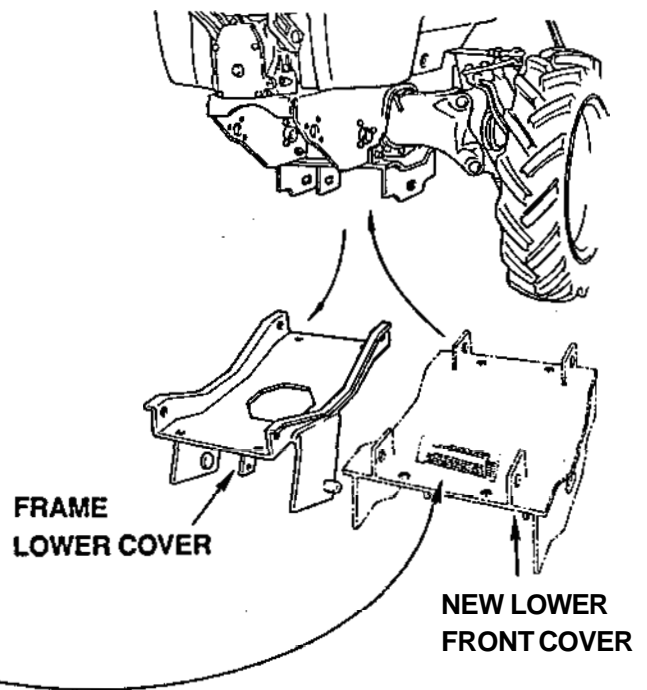

2. Remove the drawbar and replace it with the bottom bracket using the two 12 x 25 mm hex hd capscrews with 7/16" washers and two 10 x 30mm hex hd capscrews with 3/8" washers.

Torque front cover and rear bracket bolts as follows:

- 10mm Bolts 29 ft-lbs. (29 Nm).
- 12mm Bolts 43 ft-lbs. (60 Nm).

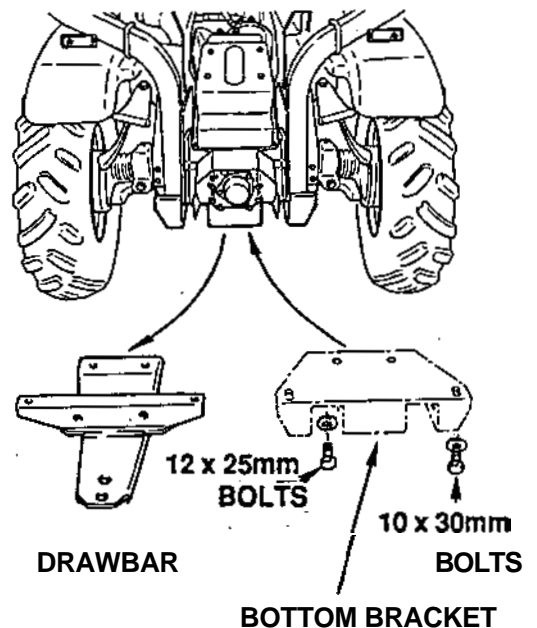

3. Lay the sub-frame on a level, solid area.

4. Position the tractor in line with the sub-frame and tire guide on drive on plate, allowing a clearance of approximately 60mm (2.4in) between sub-frame and the inner wall of the left front tire.

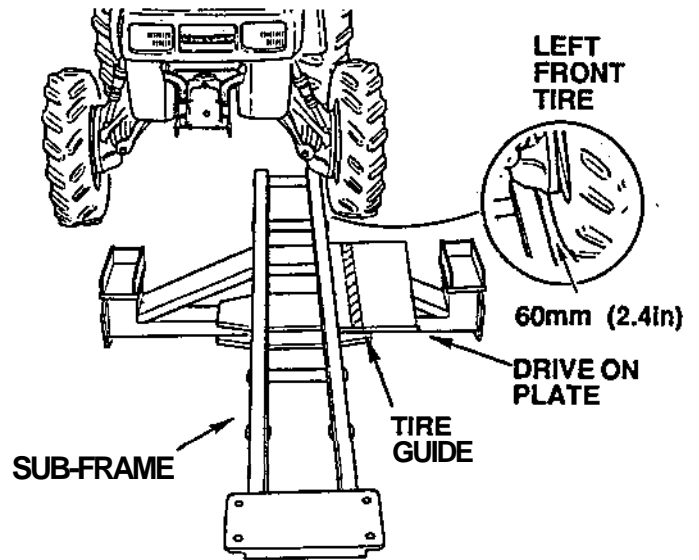

5. Drive the tractor forward the rear of the sub-frame, over the drive on plate keeping it parallel with the sub-frame.

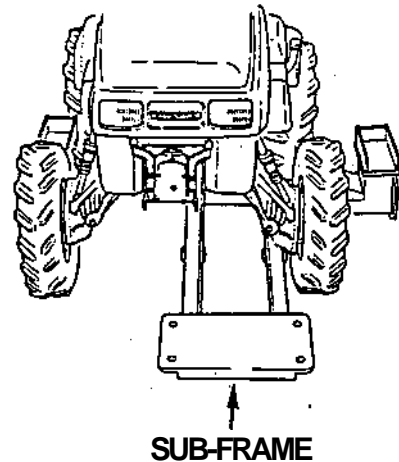

6. Stop the tractor when the mast fixing pad comes even with the floor board of the tractor.

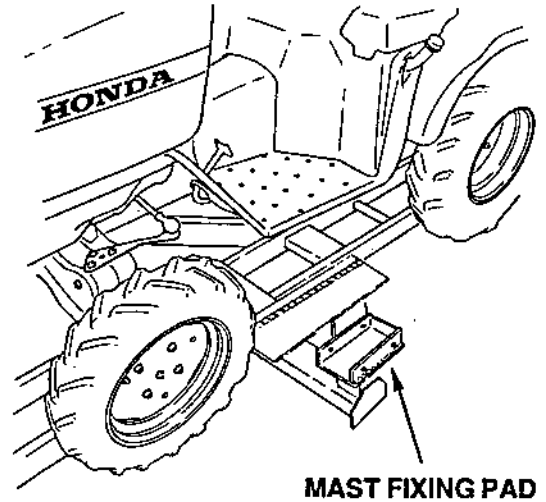

7. Using two people, lift the sub-frame and engage the pipe of sub-frame into the U-shaped channel of the bottom bracket.

NOTE: Use two people to lift sub-frame.

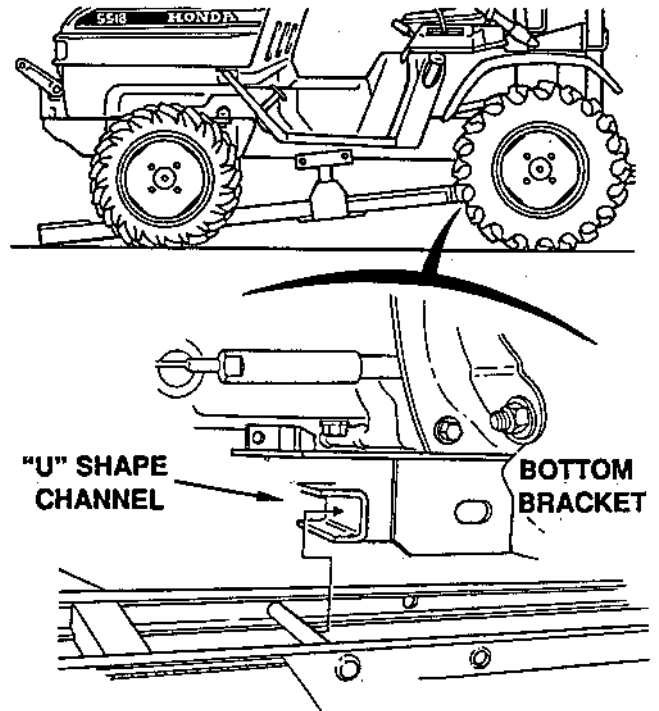

- Lift the front of the sub-frame and slip it into the channel of the lower cover. Insert two mounting pins (3/4 x 3.19in) from inside sub-frame through frame lower cover. Slip a 3/4in washer over each mounting pin and insert the clip pins through the holes.

NOTE: Mounting pins have a flat side that must be pointing down.

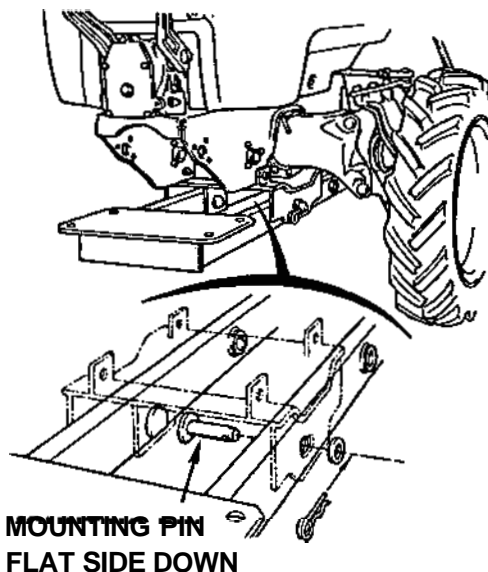

- Insert two mounting pins (3/4 x 3.19in) from inside the bottom bracket through the sub-frame. Slip a washer over each pin and retain with a clip pin as shown.

NOTE: Mounting pins have a flat side that must be pointing down.

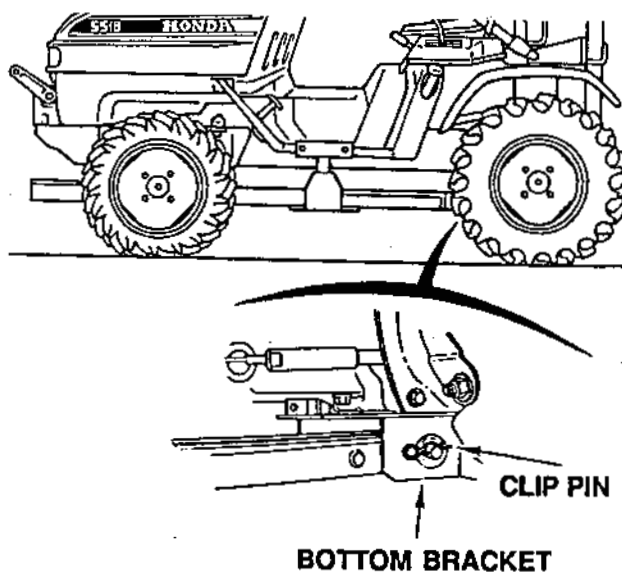

**COUNTERWEIGHT BRACKET
INSTALLATION**

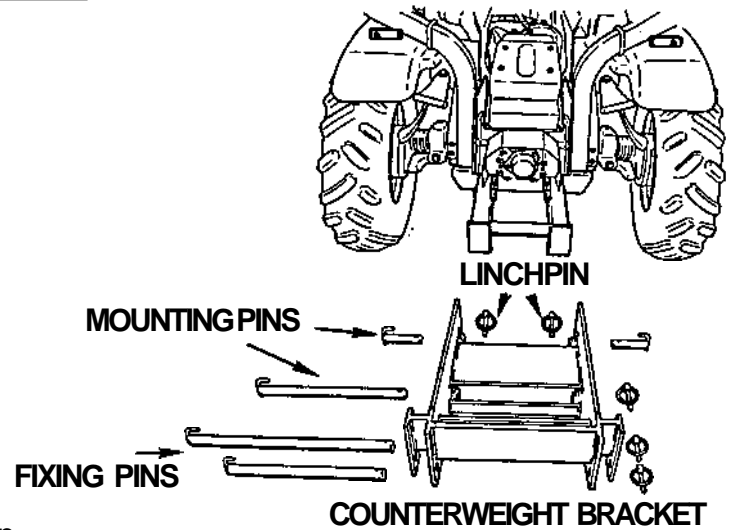

- Place the rear counterweight bracket on the rear of the sub-frame aligning the mounting holes of the bracket with those of the sub-frame. Insert two 1 x 3.5 inch mounting pins in the forward holes and one 1 x 12 inch mounting pin in rear lower hole. Secure with linchpins.

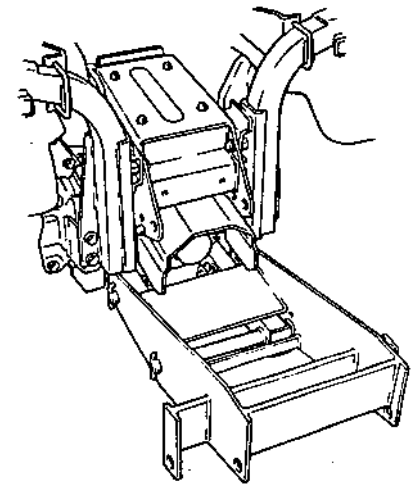

- Install the twelve counterweights. Insert the counterweight fixing pins through the bracket and secure with linchpins.

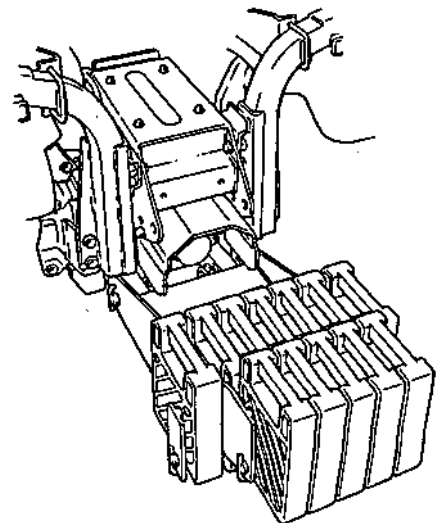

NOTE: For sub-frame removal use reverse procedures.

FRONT LOADER ASSEMBLY

HYDRAULIC PUMP MOUNTING

1. Pump mounting plate and pump drive joint are installed on pump. Ensure bolts and set screw are tight.

Attach the pump brackets to the pump mounting plate using two each 5/16x2 inch bolts and 5/16" flatwashers. The right bracket is shorter than the left. Do not tighten the bolts at this time.

Apply a light coating of grease to tractor front PTO at this time.

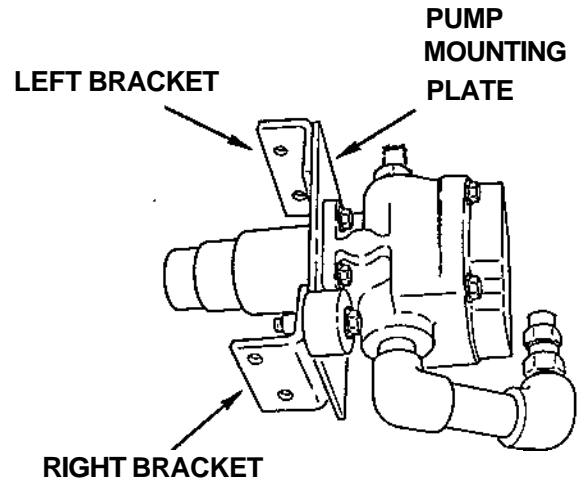

2. Mount hydraulic pump to tractor by sliding splined pump drive joint onto front PTO shaft with mounting brackets inside main frame and attaching with four 5/16x7/8 inch bolts and 5/16" lockwashers. Tighten all pump mounting bolts.

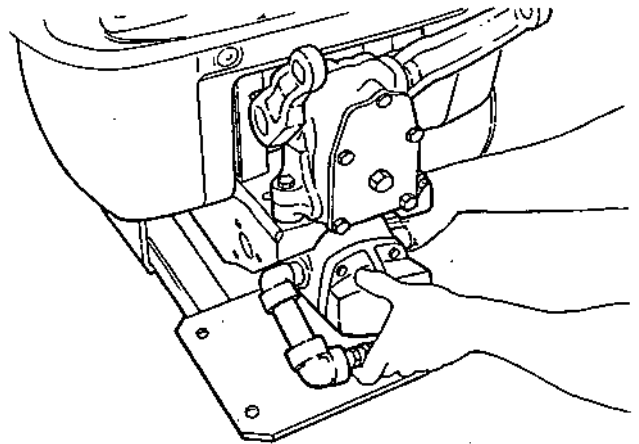

LOADER INSTALLATION

NOTE: The masts and main frame come assembled. All cylinders and hoses have been attached to the frame except the two hoses from the hydraulic pump.

3. Set the loader on its stands and move the tractor centrally between the masts.

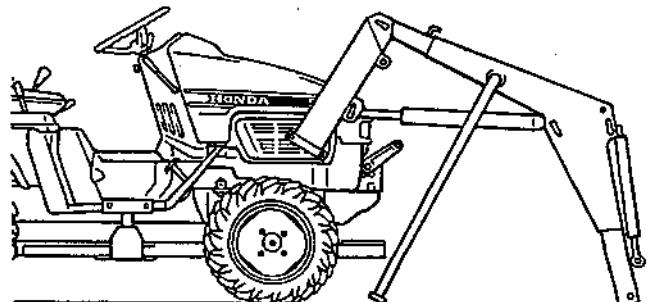

PRESSURE and SUCTION HYDRAULIC HOSE CONNECTION

4. Remove the pipe plug from the valve body and clean the threads and then install the pressure hose. Remove the plastic caps from the pump outlets. Use sealer on threads and screw the other end (swivel connector end) into the threaded pipe fitting on the pump. Slide the suction hose (large hose) over the pipe end at the bottom of mast reservoir and pipe end on the pump. Attach with hose clamps and tighten securely.

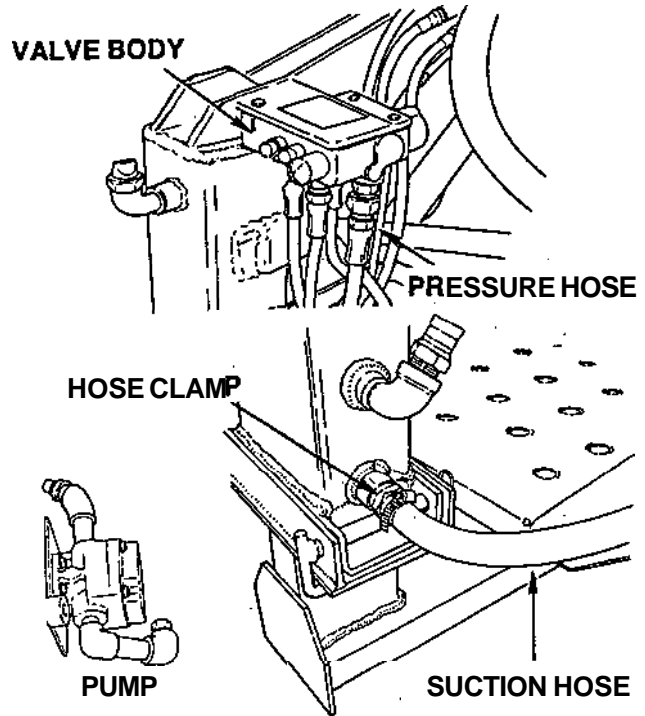

5. Attach the front guard on the front of the sub-frame using two each 1/2 x 1 inch and 1/2 x 15/16 inch bolts, and four each 1/2 inch nuts and washers. Do not tighten bolts at this time.

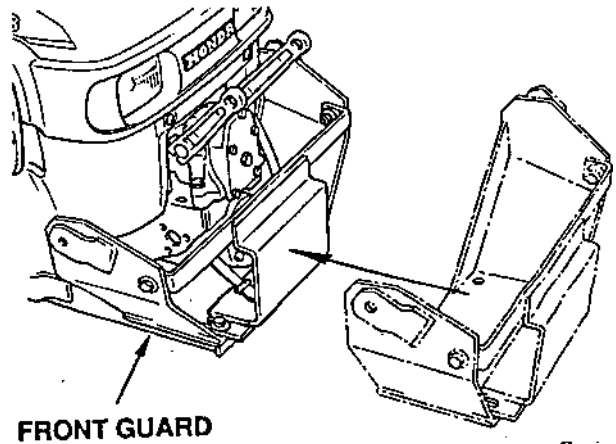

ATTACHING LOADING MASTS

6. Move the tractor until the masts are positioned over the upright pads on the sub-frame, use two people to lower the masts onto the pads and insert the fixing pins through the masts and pads. Install clip pins to retain fixing pins.

NOTE: Masts may have to be shaken to align fixing pin holes.

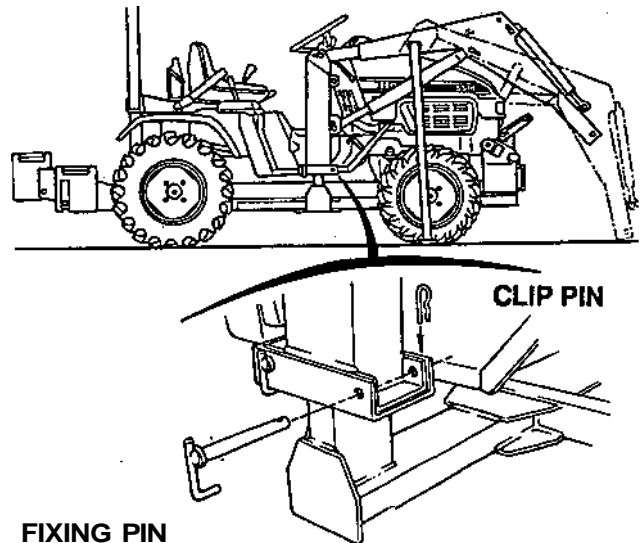

- Attach brace arms to masts with clevis pins and clip pin.

Tighten front guard bolts installed in step 5.
Torque: 76 ft-lb (1 03 Nm).

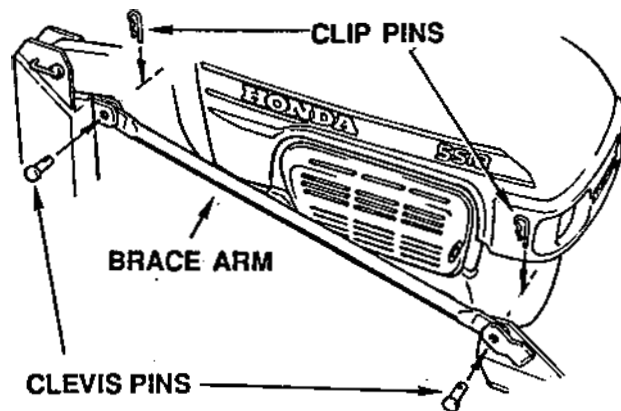

- Bring the two hoses along the left side brace arm to the left mast. Route hoses on the left brace arm with metal loops. Ensure that the high pressure hose (smaller diameter) is positioned on top of the suction hose (large diameter). Install the nylon tie strap to bind the two hoses together at front corner of hoodline.

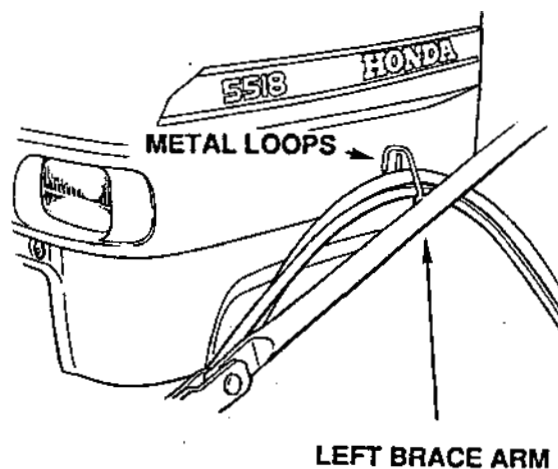

- Install valve handles to the hydraulic control valve mounted on the left mast. The "A" handle attaches to the spool used for loader operation and the "B" handle attaches to the spool for bucket operation.

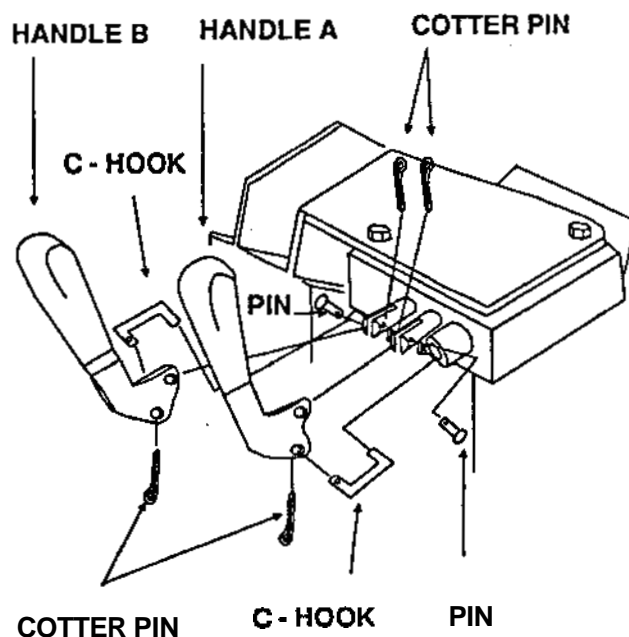

BUCKET ATTACHING

- Using the bottom holes on the bucket, attach both sides of bucket to loader frame. Use two each 3/4 x 3 inch pins and clip pins.

Attach both cylinders to top holes on bucket. Use two each 3/4 x 3 inch pins and clip pins.

The loader is now ready for hydraulic fluid.

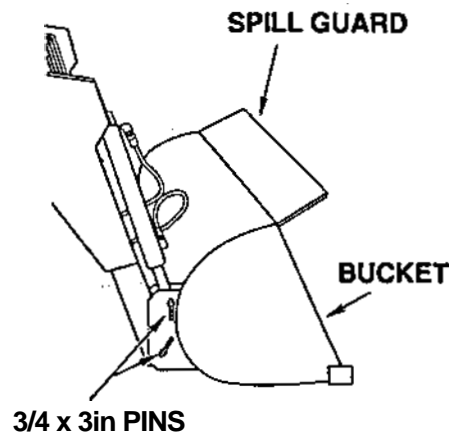

HYDRAULIC FLUID SERVICING

You will need 6 1/2 quarts of a good grade hydraulic fluid or ATF automatic transmission fluid.

- Remove filler plug and oil check screw on back of left mast. Fill with 4 quarts of hydraulic fluid.

Start tractor engine and set speed at 1/2 throttle. Engage tractor front PTO and operate loader lift and bucket cylinders at least five or six times to purge the system of air. Lower the loader to the ground.

Retract bucket cylinders by pulling back on handle "B".

Add 2 1/2 more quarts of hydraulic fluid or until oil runs out of check hole. Replace oil fill plug and oil check screw.

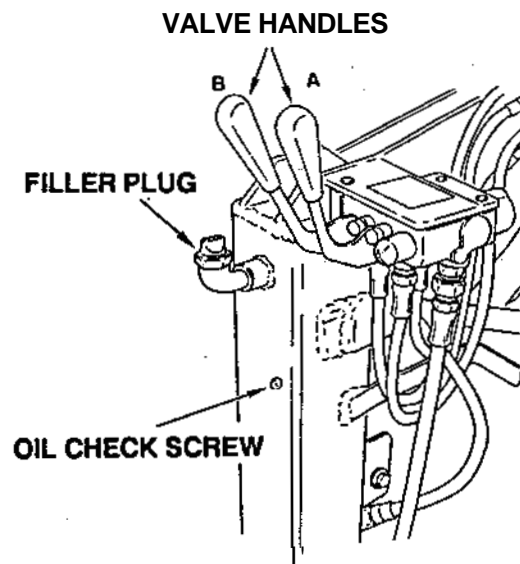

NOTE: When lowering loader, DO NOT push loader handle "A" all the way forward into FLOAT.

LOADER STAND REMOVAL

12. Raise the loader with the loader control until the stands clear the ground.

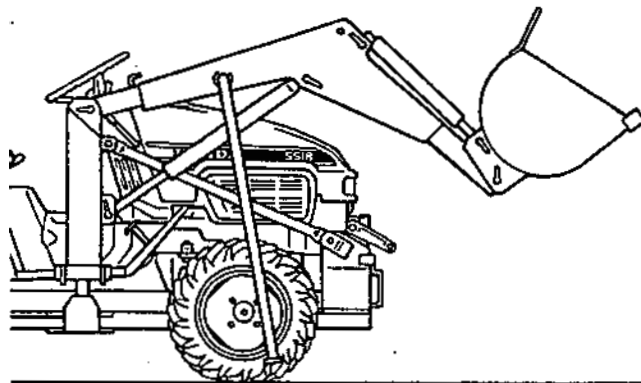

13. Remove latch pin from the stands and remove the stands.

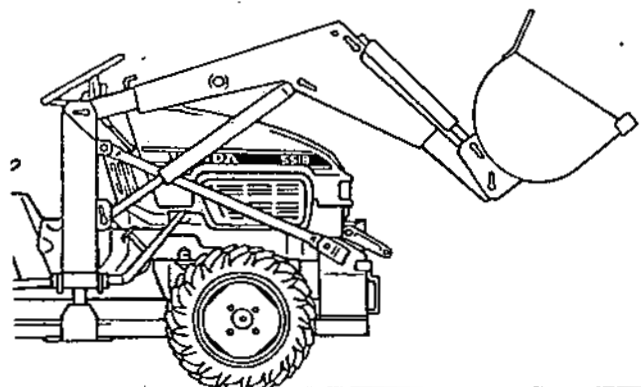

14. Align the hole in the bottom of the stand with the mounting hook at rear of mainframe. Slide the stand over the mounting hook and then insert the latch pin previously removed through main frame and through the stand. Repeat the above steps for the other side. Lower the loader to the ground.

Front Loader is ready to become operational.

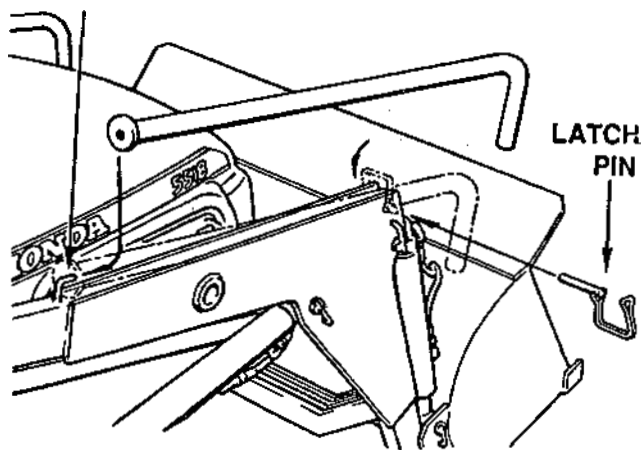
MOUNTING HOOK

OPERATIONAL CHECK

Check all pivot points on the loader.
Lubricate as necessary.
(See lubrication chart.) on page number 44

Check loader hydraulic fluid.

Note: Check fluid level with loader arms down and bucket flat on the ground.

Remove oil check screw and see if oil will run out hole. (Do not overfill)

If oil level is low, remove oil fill plug and add hydraulic fluid until it runs out of oil check hole.

Re-install and tighten the oil check screw and oil fill plug. Operate the loader up and down several times and recheck oil level.
Replenish as necessary.

Operate and check the loader main frame and bucket for interference, noise, and bending of parts.

CAUTION -- Before using loader, double check:

- Tractor Owner's Manual for recommended tire pressure
- That all bolts and hoses have been tightened and that all tools have been removed from tractor and loader.
- Counterweights are Installed and correct.

START UP PROCEDURE

Ensure tractor meets all requirements in Tractor Preparation Section.

Check front loader hydraulic fluid level. Refer to front loader operator's manual.

Note: Bucket and lift cylinders should be fully retracted when checking hydraulic fluid level:

Check all hydraulic hose connections to ensure that they are not leaking.

Lubricate all pivot points that incorporate grease fittings.

Start tractor and run engine at approximately 1200 - 1400 RPM for initial cycling of loader.

Push PTO lever forward to "ON"

WARNING -Before using front loader for the first time, cycle lift and bucket cylinders to purge air from cylinder. Air in the hydraulic system can cause unexpected fall of main frame, causing Injury or damage to loader or tractor.

Cycle lift and bucket cylinders with bucket empty several times to seat-in cylinder components.

Check all hydraulic hose routings to ensure adequate clearances exist between hoses and adjacent components.

WARNING -The tractor front loader should only be operated with all safety equipment properly installed.

CAUTION -Operate loader from the tractor seat only. Engine will not run with PTO engaged unless operator's seat is occupied.

OPERATING TIPS

NOTICE -Do not use the bucket for pushing down material with bucket cylinders partially extended. Cylinder and rod may be damaged.

Do not tip bucket cutting edge down (fully extend bucket cylinders) during backfilling/backgrading operation. Cylinder and rod may be damaged.

Position vehicles to be loaded as near the pile as possible and in such a direction as to minimize the amount of tractor turning required to dump.

Do not use the spill guard to push objects as it will deform and become damaged.

Keep the unit clean and perform regular service. Observe safety instructions whenever cleaning, servicing, or lubricating.

We urge you to follow this advice:

1. Read and understand this manual as well as the tractor owner's manual.
2. Remember and observe the Safety Precautions brought to your attention in this manual, the tractor manual and on the loader itself.
3. Use good common sense in the everyday operation of this unit, Safety instructions can never be all inclusive. You are responsible for watching out for, and avoiding, unsafe conditions.
4. Never exceed the limits of a piece of machinery. If its ability to do a job or to do so safely is in question—Don't try it.
5. Don't hurry the learning process or take the unit for granted. Ease into it and become familiar with your new loader and tractor.

6. When lowering a heavy load, ease it downward slowly. Never drop a loaded bucket and "catch" hydraulically. Stopping a load after it has gained downward momentum places undue strain on the unit and may cause damage to the loader or tractor.

⚠ WARNING —Before disconnecting hydraulic lines, relieve all hydraulic pressure. Escaping hydraulic oil under pressure can have sufficient force to penetrate the skin causing serious personal injury. If injured by escaping hydraulic oil, consult a physician immediately.

⚠ WARNING —Do not operate the loader if the hydraulic fittings or hoses are leaking or damaged. A sudden line burst can cause the main frame to drop suddenly, causing damage to the tractor or loader or injury to personnel.

BEFORE OPERATING, LUBRICATE ALL MOVING PARTS. (Refer to lubrication section)

COLD WEATHER OPERATION

To assure smooth operation in cold weather, allow the tractor to warm up. Slowly cycle the loader and bucket several times to warm the fluid in the hydraulic system. The loader may operate erratically until the hydraulic fluid has warmed to operating temperatures.

OPERATING INSTRUCTIONS

Main, lift and bucket cylinders are double acting type (both push and pull under hydraulic power). This means that the loader can be forced down as well as up. It means that the bucket can be tilted down or up with hydraulic pressure.

HYDRAULIC CONTROL VALVE

Your loader control valve has two handles. The right handle operates the lift cylinders (the loader) and has a float position. The left handle operates the bucket cylinders. Both handles will return to neutral except from float position when released.

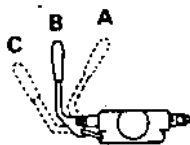

LEFT HANDLE — BUCKET

- A — Bucket Dump
- B — Neutral
- C — Bucket Back

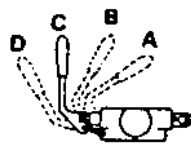

RIGHT HANDLE — LOADER

- A — Float Position
- B — Loader Down
- C — Neutral
- D — Loader Up

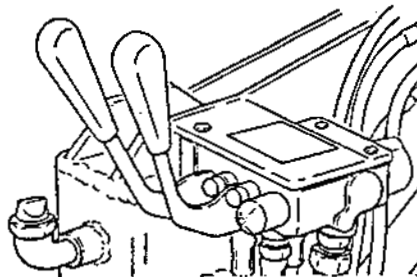

HANDLE USE

BUCKET

POSITION A —Left handle pushed forward, bucket will dump.

POSITION B —Neutral position.

POSITION C —Left handle pulled back, bucket will roll back.

LOADER

POSITION A —Right handle pushed all the way forward (this is float position). Handle will stay until pulled back.

POSITION B —Right handle pushed half way forward, bucket will lower.

POSITION C —Neutral position.

POSITION D —Right handle pulled back, bucket will raise.

Note: In float position there is no hydraulic pressure going to the lift cylinders. If the loader frame is up off the ground, it will lower to the ground by gravity. When the bucket is on the ground (and the valve is still in float) the bucket will follow the shape of the ground even when the tractor is moving. This allows hydraulic oil to flow back and forth in the hydraulic system as the loader is raised and lowered by the ground contour.

CAUTION —Do not allow bucket lip to dig into ground when tractor is moving forward in float. The bucket bottom should be level with the ground or slightly rolled back.

NOTE: The float position is most commonly used with attachments in snow removal. Tractor should be run at slow ground speed and the lift and bucket cylinders used to work material loose and fill the bucket.

CONTROLLED RATE of LOADER FUNCTIONS

By feathering (slightly moving) the control levers, precise operational speeds can be obtained. This action controls the position of the valve spools in the control valve and regulates flow of oil from/to cylinders.

It is important to utilize this operational practice when lowering the main frame when the bucket is loaded with material.

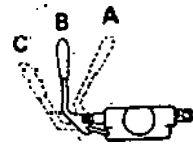

- LEFT HANDLE—BUCKET**
- A — Bucket Dump
 - B — Neutral
 - C — Bucket Back

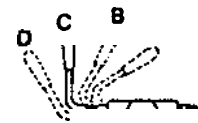

- RIGHT HANDLE — LOADER**
- A — Float Position
 - B — Loader Down
 - C — Neutral
 - D — Loader Up

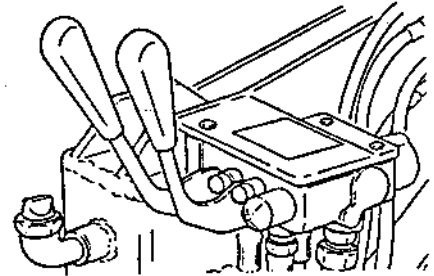

SCRAPING

When scraping, the "float" position should be utilized to maintain the bucket firmly on the ground and at the same time allow the bucket to follow ground contours.

The bucket should be positioned level to the ground during "scraping" operations.

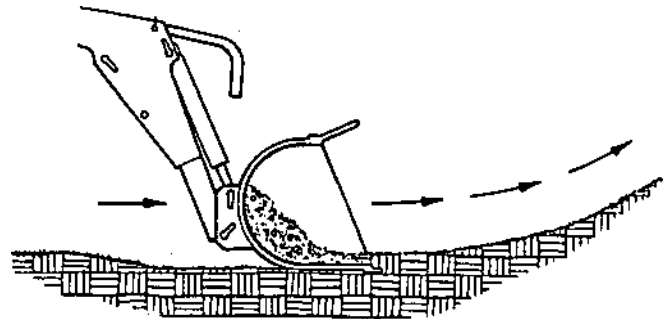

BACKFILLING/BACKGRADING

When "backfilling" or "backgrading", position the bucket so it is level on the ground. Do not dump material from the bucket. Additional weight of material in bucket will assist in "backgrading" and increases loader efficiency during "backfilling".

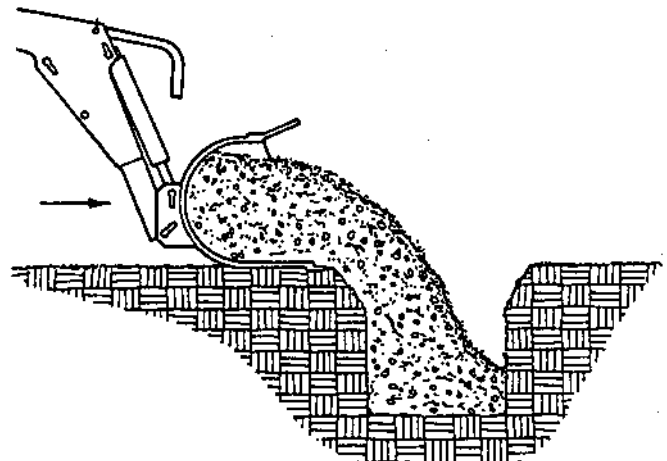

LOADING

Drive straight ahead into pile with bucket cutting edge level with the ground. In order to prevent possibility of damaging tractor or loader;

- Do not ram into pile at high speed.
- Do not attempt to turn tractor while loading.

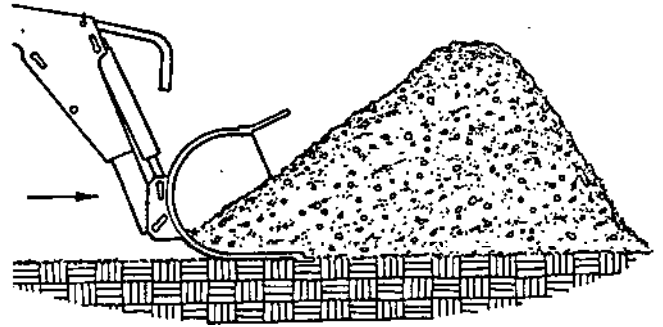

As bucket begins to fill with material, gradually roll the bucket back and raise the loader to increase "fill" capacity. This procedure also results in the material being removed in layers from the top for maximum loading efficiency.

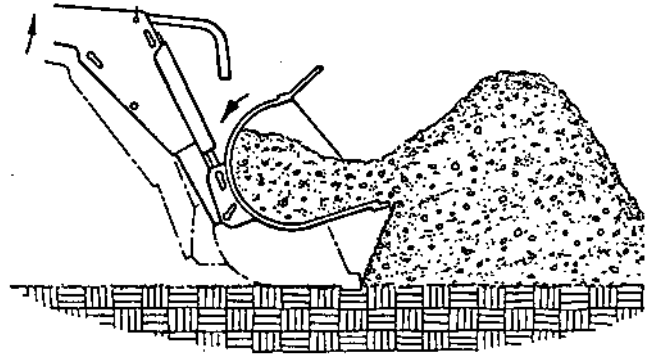

When the bucket is full, raise loader so that the bucket is clear of material and slowly back out of pile.

For maximum loading efficiency, minimize angle of turn and distance between the loading and unloading points.

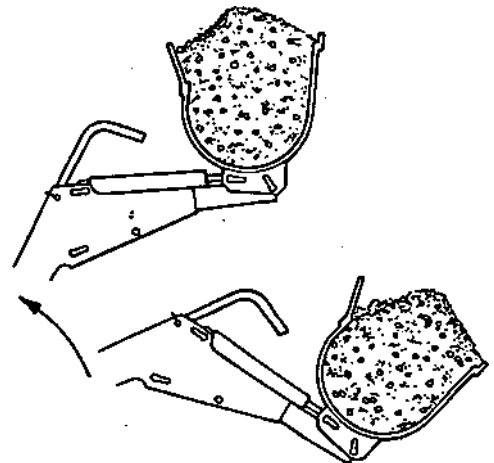

TRANSPORTING MATERIAL

Transport material to "unloading point" with loader bucket as low as possible to prevent spillage and maintain maximum tractor loader stability.

NOTICE — During transport the loader should be in a position that will not impair operators vision,

Observe the following safety messages.

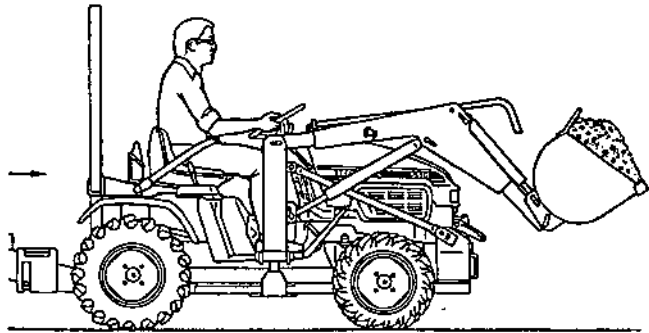

DANGER — Avoid any overhead wires or obstacles when loader is raised, to avoid damage or possible death by electrocution.

WARNING — A loaded bucket should be transported in a low position at slow ground speeds, especially if the ground is irregular. Make turns slowly and use the tractor brakes cautiously. A full bucket in the raised position alters the center of gravity of the unit and increases the possibility of mishaps.

WARNING — Do not lift or carry personnel on a loader or attachment; a slip or fall could cause serious injury.

UNLOADING

As the tractor approaches the "unloading point", raise the loader to the height required for clearance to "dump" bucket.

Drive slowly to position bucket above "unloading point", stop tractor and dump bucket.

NOTE: Do not raise loader higher than required for "dumping" clearance.

As "dumping" clearance height increases, the bucket position must be adjusted to maintain a level bucket to prevent excessive spillage of material from bucket.

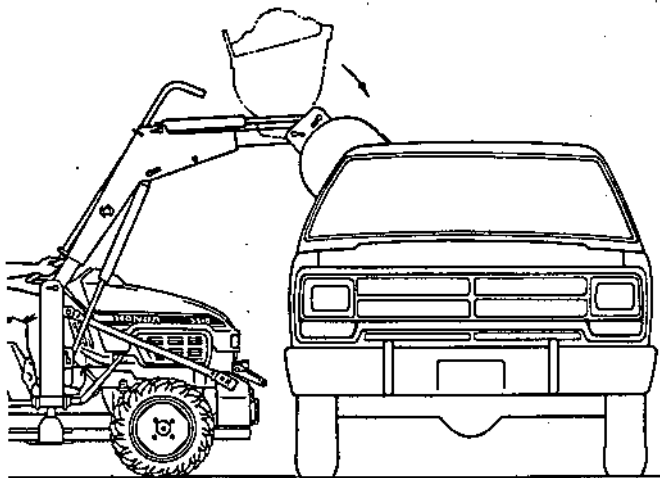

LOADER REMOVAL FROM TRACTOR

1. Select a level, safe, and solid place for loader removal. Lower bucket to the ground and remove the stands from the loader main frame.

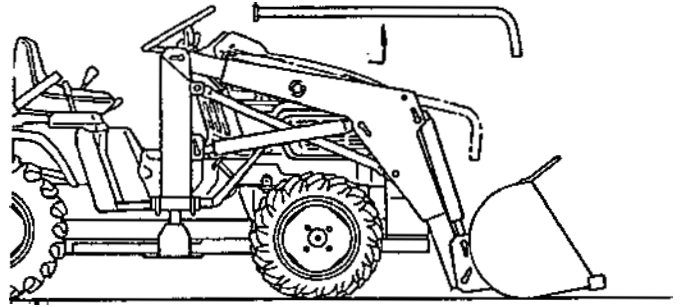

2. Raise the loader until the stands can be inserted into the loader arms.

Install the clip pins into the stand ends.

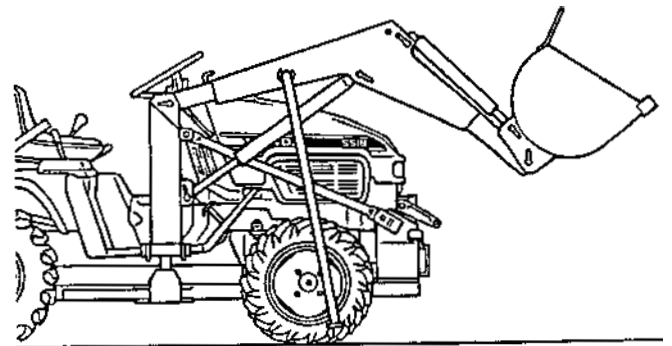

3. Lower the loader until the stands rest on the ground.

Dump the bucket until the edge of bucket touches the ground.

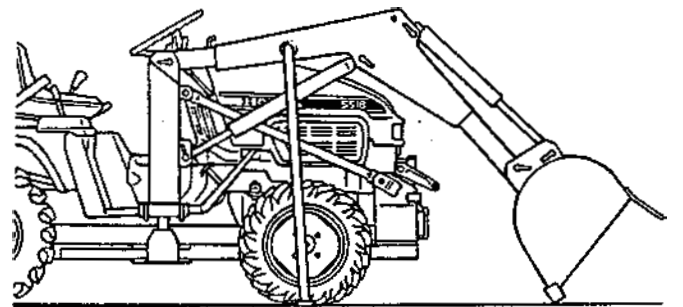

LOADER REMOVAL FROM TRACTOR

- Using the bucket to support the loader main frame, remove loader mast fixing pins.

Note: Use bucket operation to make fixing pin removal easier.

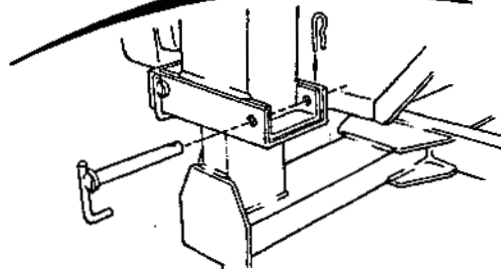
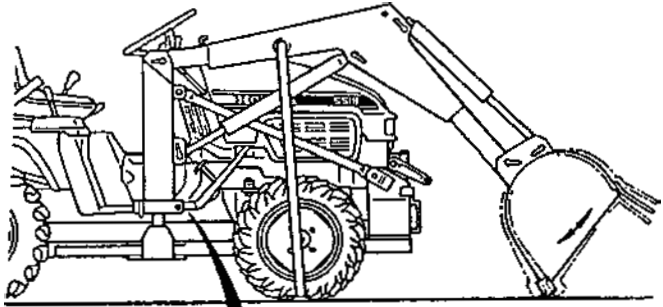

- Remove the clip pins and mounting pins from the masts and the front guard. Remove the hydraulic hoses from the left brace loops.

Remove the brace arms.

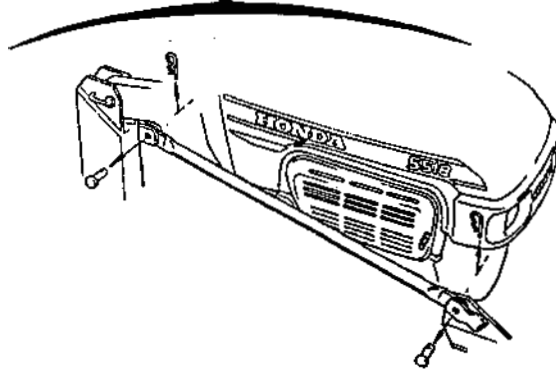
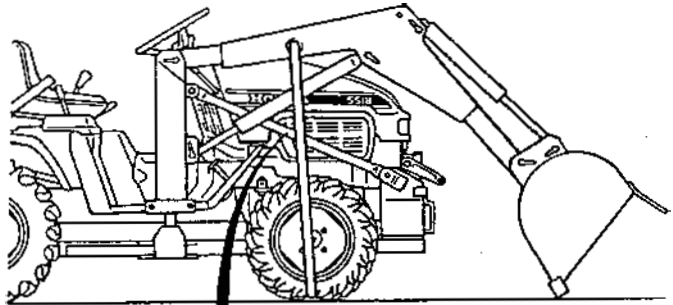

- Roll back the bucket to detach loader from sub-frame. Operate the bucket slowly to avoid loader to tractor interference.

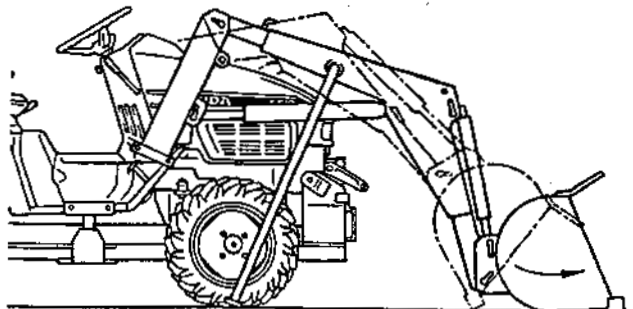

7. Put the tractor in reverse and drive it back 2 feet. Remove the front guard from sub-frame.

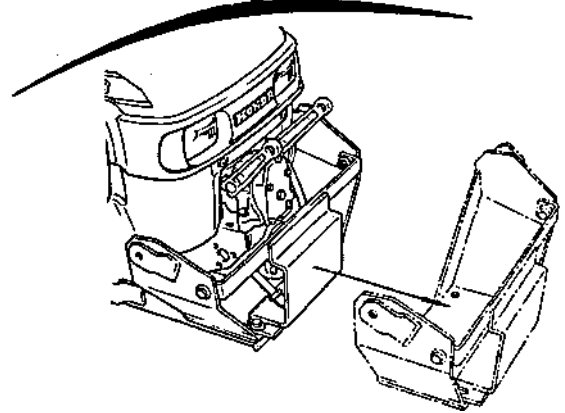
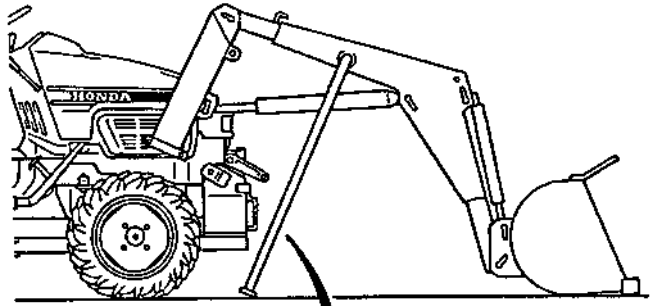

8. Remove the hydraulic pump by removing the four bolts holding the mounting brackets to the tractor frame.

Remove the pump from the PTO shaft.

NOTE: Do not disconnect hoses.

Loader is now parked and ready for storage.

For sub-frame removal see pages 13 thru 17.

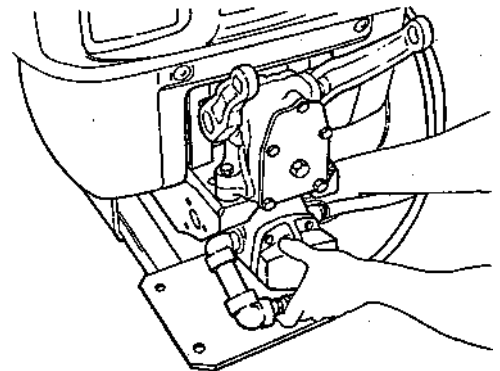

STORAGE

END OF SEASON

1. If loader is to be dismantled from the tractor during storage, make sure parking area is on hard, level ground.
2. Store in a dry, sheltered area, if possible.

Note: All hydraulic cylinders should be in the retracted position.

3. Thoroughly clean the loader of all accumulated dirt and grease.
4. Completely lubricate the loader as specified in lubrication section of manual.
5. Using an oil soaked cloth, lubricate all hydraulic cylinder rods to protect them from rust and corrosion.
6. Repaint any areas where paint is worn or damaged.
7. Wear areas on buckets or other attachments should be coated with grease to prevent rust or corrosion.
8. Replace any safety or warning labels that are not readable due to wear or damage.

 WARNING —Do not allow children to play on or around the tractor or loader.

PROCEDURES

BEGINNING OF SEASON

1. Review safety precautions and operation sections of manual.
2. Thoroughly clean loader of all accumulated dirt and grease.
3. If removed from tractor for storage, remount loader per “Loader Installation” section of this manual.
4. Completely lubricate the loader per the lubrication section of this manual. Make sure all fittings are taking grease properly.
5. Clean with solvent any exposed surfaces which had been coated with grease. Wipe dry with a clean cloth, then lubricate with an oil soaked cloth.
6. Tighten any bolts that may have been loosened and make sure all pins are in place.
7. Start tractor and operate loader to make sure it is operating properly and all hoses are properly connected.
8. Check hydraulic fluid level in loader mast and fill if required. Use oil recommended in this manual.
9. Make sure, hydraulic hoses, lines and fittings are in good shape and are not leaking. Repair or replace as, needed.

LOADER INSTALLATION

NOTE: Install sub-frame and weights (Page 13 - 17).

The sub-frame, masts and main frame are assembled. All cylinders and hoses are attached to the loader frame and hydraulic pump.

1. Move the tractor centrally between the masts.

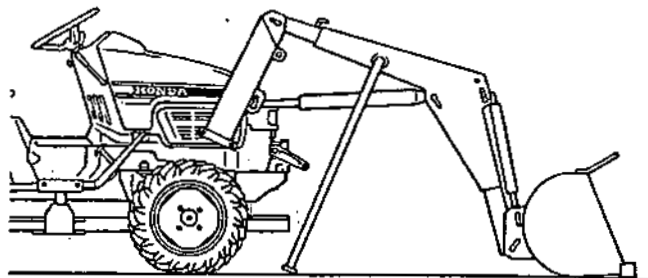

2. Mount hydraulic pump to tractor by sliding splined pump drive joint onto front PTO shaft with mounting brackets inside main frame and attaching with four 5/16 x 7/8 inch bolts.

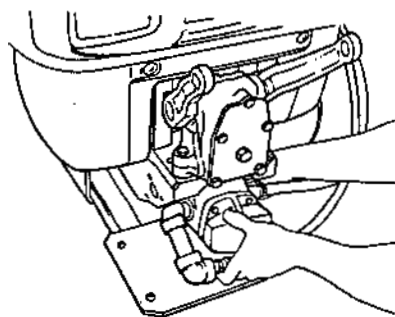

3. Attach the front guard on the front of the sub-frame using two each 1/2 x 1 inch and 1/2 x 1 5/16 inch bolts, and four each 1/2 inch nuts and washers. Tighten bolts and nuts.

Torque: 76 ft-lb (103 Nm)

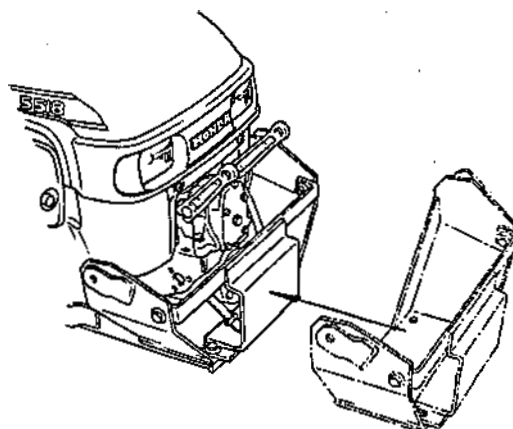

ATTACHING LOADER MASTS

4. Move the tractor until the masts are positioned in line with upright pads on the sub-frame, use two people and the bucket to lower and guide the masts onto the pads.

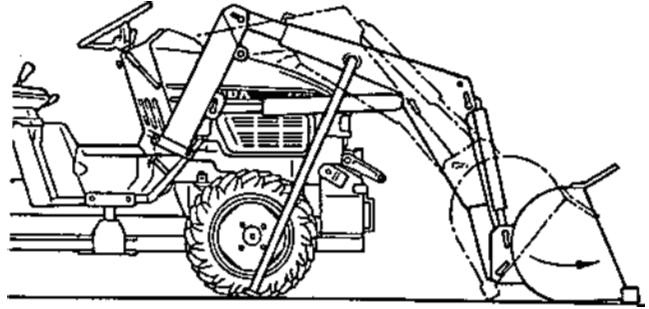

5. Use bucket movement to shake masts to align pin holes. Insert the fixing pins through the masts and pads. Install clip pins through holes.

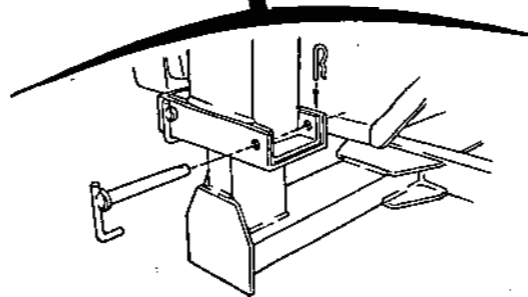
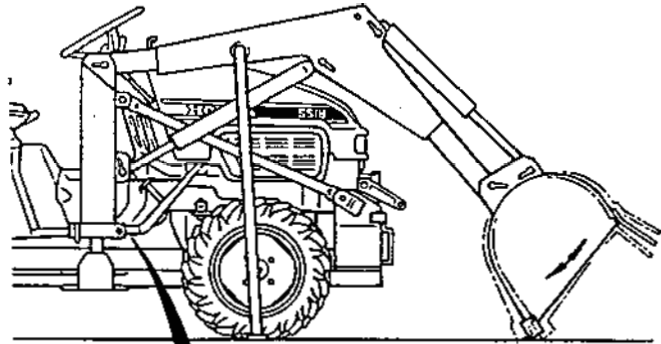

6. Attach brace arms to mast and front guard as shown with clevis pins and clips.

NOTE: Route hydraulic hoses along left brace arm through hose holder loops.

Ensure high pressure hose (smaller of two) is positioned on top of larger suction hose.

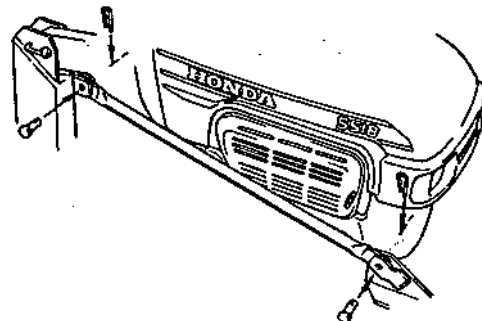

LOADER STAND REMOVAL

7. Raise the loader with the loader control until the stands clear the ground.

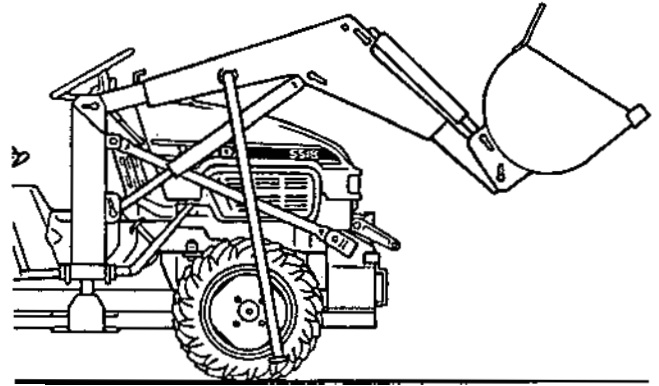

8. Remove fixing pin from the stands and remove the stands.

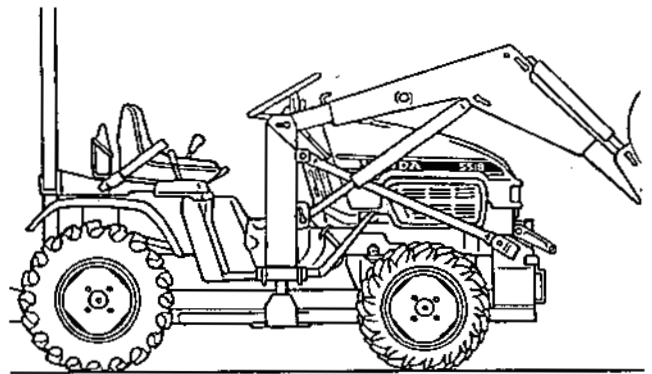

9. Align the hole in the bottom of the stand with the mounting hook at rear of mainframe. Slide the stand over the mounting hook and then insert the fixing pin previously removed through main frame and through the stand. Repeat the above steps for the other side. Lower the loader to the ground.

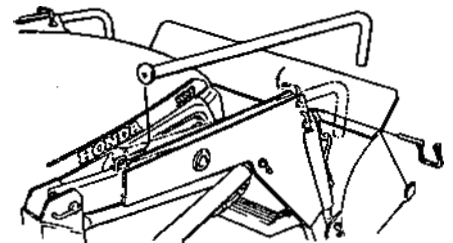

Front Loader is ready for operational check.
(Page 25)

TROUBLE SHOOTING

SYSTEM DOES NOT WORK AT ALL

PTO in 'OFF' position — Put to 'ON'.

No oil in system — Fill to proper level. Check system for leaks.

Oil low in reservoir — Check and fill to proper level. Check system for leaks.

Restriction in system — Oil suction line could be collapsing to cut off oil supply. Replace line.

Air leaks in pump suction line — Check hose clamps or replace hose.

Dirt in pump — Clean and repair pump. If needed, drain and flush hydraulic system.

Badly worn pump — Check for problems causing pump wear.

Oil leak in pressure lines — Tighten fittings or replace defective lines.

Hoses attached improperly — Attach properly and tighten securely.

Control Valve Defective — Replace

SYSTEM RUNS WITH STOPS AND STARTS

Air in system — Examine suction side of system for leaks. Make sure oil level is correct. To get air out of system after oil level is correct and leaks fixed, use bucket and loader cylinders 5 to 6 times to purge the system of air.

Cold oil — Oil viscosity may be too high at start. Before operating, allow oil to warm up.

Components sticking or binding — Check for dirt or gummy deposits.

Pump damaged — Check for worn or broken parts.

SYSTEM RUNS OR WORKS SLOWLY

Cold oil — Allow to warm up before operating.

Oil viscosity too heavy — See specifications on proper oil.

Not enough engine speed — Increase engine speed.

Low oil supply — Check reservoir and add oil if needed. Check system for leaks that could cause low oil.

Air in system — Check suction side of system for leaks.

Badly worn pump — Repair or replace pump. Check for problems causing pump wear such as contaminated oil.

Restriction in suction line — Suction line could be dirty or have inner walls that are collapsing to cut off oil supply. Clean or replace suction line.

Oil leaks in pressure lines — Tighten fittings or replace defective lines.

OVERHEATING OF OIL IN SYSTEM

Using incorrect oil — See specifications on proper oil.

Low oil level — Fill reservoir. Look for leaks.

Engine running too fast — Reduce throttle.

Restriction in hydraulic line — Clean or replace.

Controls stuck in partially or full open position — Free both handles so they return to neutral.

FOAMING OF OIL IN SYSTEM

Low oil level — Fill reservoir. Look for leaks.

Water in oil — Drain and replace oil.

Wrong kind of oil being use — See specifications on proper oil.

Air leak in line from reservoir to pump — Tighten or replace suction line.

Kink in oil suction line — Replace oil line.

Worn seal around pump shaft — Clean sealing area and replace seal. Check oil for contamination.

PUMP MAKES NOISE

Low oil level — Fill reservoir. Check system for leaks.

Oil viscosity too high — See specifications on proper oil.

Cold oil — Allow oil to warm up before operating.

Suction line plugged or pinched — Clean or replace line between reservoir and pump.

Reservoir air vent plugged — Remove vent plug, flush, and clean air vent.

Air in oil — Tighten or replace suction line. Check system for leaks. Check pump shaft seal.

Worn or scored pump bearings or shafts — Replace pump.

PUMP LEAKS OIL

Damaged seal around pump shaft — Replace seal.

LOAD DROPS WITH CONTROL VALVE IN NEUTRAL POSITION

Leaking or broken oil lines from control valves to cylinder — Check for leaks. Tighten or replace lines.

Oil leaking past cylinder packing or "O" rings — Replace worn parts. If wear is caused by contamination, clean hydraulic system and determine source of dirt.

Oil leaking past control valve — Clean or replace valve. Wear may be caused by contamination. Clean system and determine source of dirt.

CONTROL VALVE STICKS OR WORKS HARD

Valve broken or scored internally — Replace valve.

CONTROL VALVE LEAKS OIL

Worn or damaged "O" rings — Replace "O" rings. If contamination has caused "O" rings to wear, clean system and look for source.

Broken valve parts — Replace parts or valve.

CYLINDER LEAKS OIL

Damaged cylinder bowl — Replace cylinder. Correct cause of damage.

Rod seal leaking — Replace seal. If contamination caused seal to wear, look for source. Wear may be caused by external as well as internal contaminants. Check piston rod for scratches or misalignment.

Loose parts — Tighten parts.

Piston rod damaged — Check rod for nicks or scratches that could cause seal damage or allow oil leakage. Replace defective cylinder.

LUBRICATION and MAINTENANCE

Do not perform any service/maintenance operations with front loader raised off the ground.

Note: Lower front loader to the ground and relieve pressure in loader hydraulic lines prior to performing any service/maintenance operations on tractor or loader.

⚠ DANGER —Keep hands and body from pressurized lines. Use paper or cardboard, not body parts, to check for leaks. Hydraulic oil under pressure will penetrate the skin causing serious injury.

Make sure that all operating and service personnel know that in the event hydraulic fluid penetrates the skin, it must be surgically removed within a few hours by a doctor familiar with this form of injury, or gangrene may result.

⚠ WARNING —Do not operate the front loader if the fittings or the hoses are leaking or damaged. A sudden line burst could cause the main frame to drop suddenly, causing damage to the tractor or loader or injury to personnel.

⚠ WARNING —Accidental movement of control lever or leak in the hydraulic system could cause main frame to drop, causing serious injury. Do not stand or walk under a raised attachment.

Note: When checking hydraulic system oil level, the loader should be on the ground and bucket fully retracted (all cylinders in the retracted position). Grease all loader pivot points as indicated on lubrication chart.

Inspect hydraulic hoses, connections, control valve and cylinders for evidence of leakage

Note: If oil seepage past cylinder rod is evident, look for scoring on rod.

Tractor tire inflation should be checked as listed in tractor owner's manual to ensure tire inflation is to specification.

Unequal inflation can result in bucket not being level to the ground.

Front tires should be maintained at maximum recommended inflation to maintain normal tire profile with added loader weight and material.

LUBRICATION AND MAINTENANCE CHART

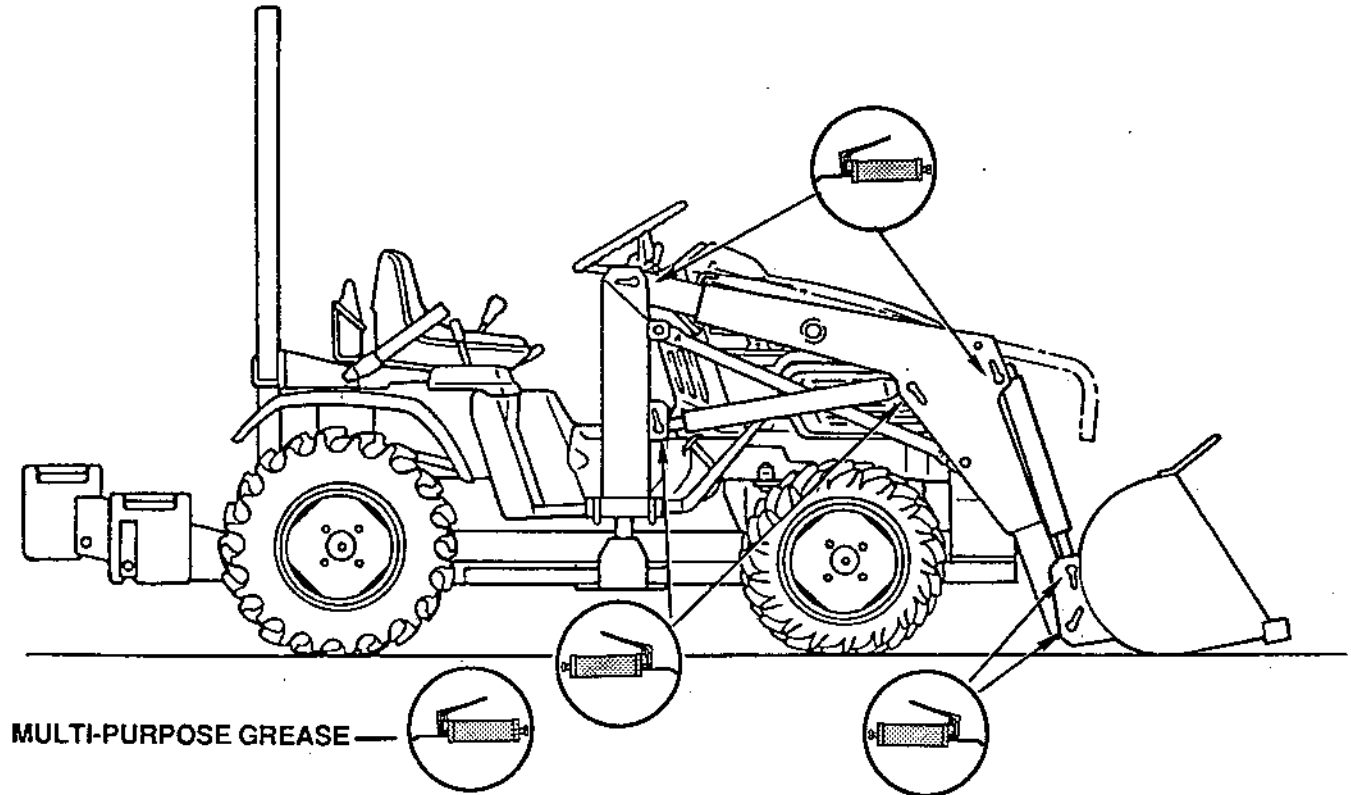

LUBRICATION AND MAINTENANCE CHART

Hydraulic oil level Check Daily/10 Hrs
Tire inflation Check Weekly/50 Hrs
Loader pivot points Lubricate Daily/10 Hrs
Hydraulic lines hoses and connections Check for leakage, wear and damage Daily/10 Hrs
Lift and bucket cylinders Check for seepage. Daily/10 Hrs
Mounting pins, Clip pins Fixing pins Check replace if missing Daily/10 Hrs
Sub-frame mounting and hardware Check Re-torque Weekly/50 Hr

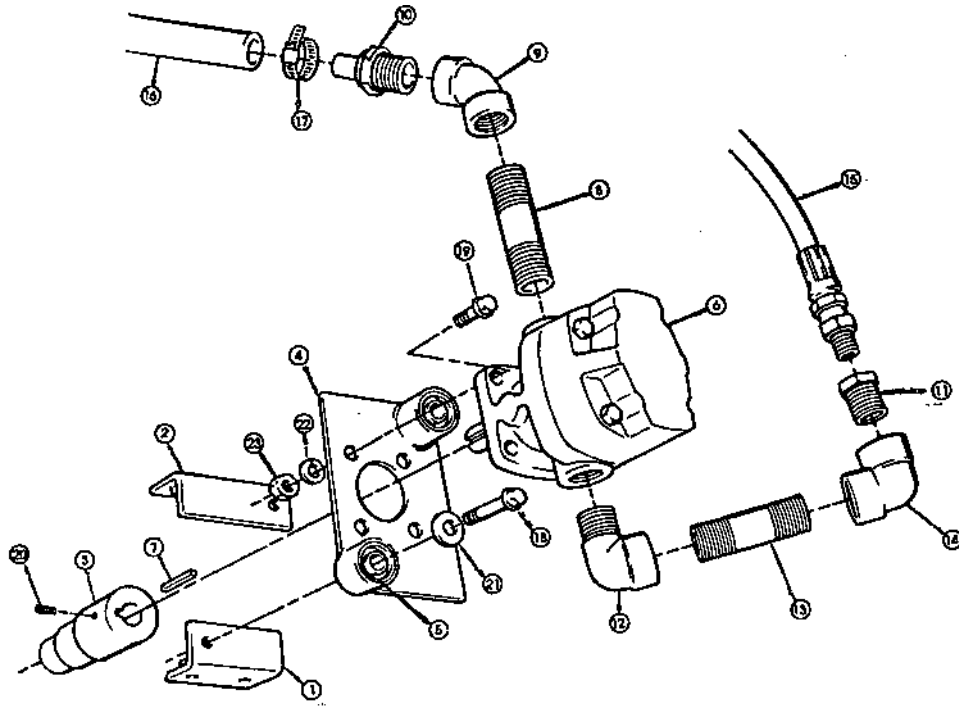

REPAIR PARTS — PUMP ASSEMBLY

P N	DESCRIPTION	QUANTITY REQ'D
1	ANGLE - RH	1
2	ANGLE - LH	1
3	PUMP COUPLER	1
4	PUMP PLATE	1
5	RUBBER BUSHING	2
6	304 PUMP	1
7	3/16 x 3/16 x 1 KEY	1
8	1/2 x 2" PIPE NIPPLE	1
9	1/2 x 45" PIPE ELBOW	1
10	1/2" PIPE END	1
11	1/2 - 3/8 HEX REDUCER BUSHING	1
12	3/8 90" ST ELBOW	1
13	3/8 x 3" PIPE NIPPLE	1
14	3/8 90" PIPE ELBOW	1
15	3/8 x 60" HYDRAULIC HOSE 9/16 - 18 ORB x 3/8MS	1
16	3/4" SUCTION HOSE	48"
17	# 16 HOSE CLAMP	2
18	5/16 - 18 x 1 3/4" HEX HEAD CAPSCREW	2
19	5/16 - 18 x 1" HEX HEAD CAPSCREW	8
20	5/16 - 18 x 1/2" SOCKET HEAD SETSCREW	1
21	5/16" FLAT WASHER	2
22	5/16" LOCK WASHER	8
23	5/16 - 18 HEX NUT	4

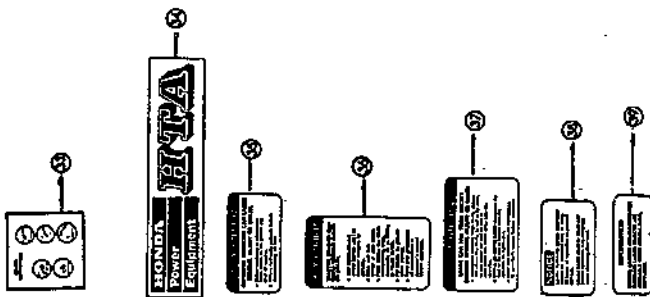
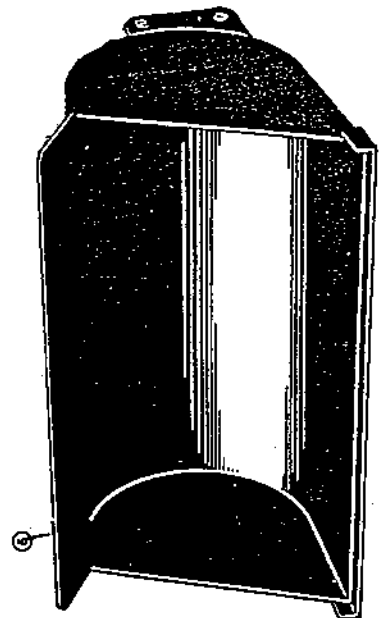
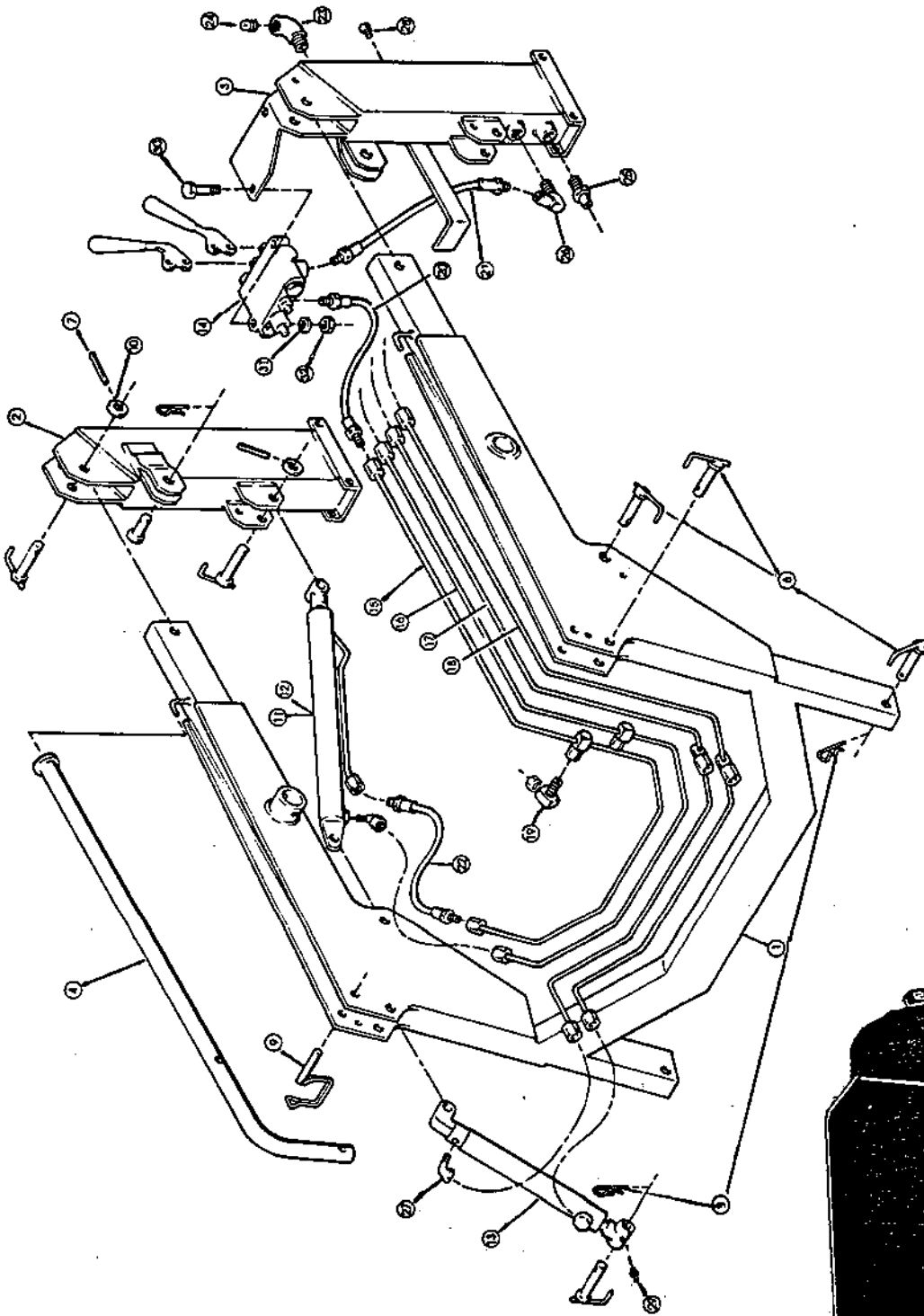

REPAIR PARTS – MAIN FRAME ASSEMBLY

P N	DESCRIPTION	QUANTITY REQ'D
1	MAIN FRAME	1
2	UPRIGHT - RH	1
3	UPRIGHT - LH	1
4	STAND	2
5	BUCKET - 42"	1
6	PIN - A	12
7	5/32 x 1" COTTER PIN	8
8	#11 CLIP PIN	4
9	3/8 x 2 1/4" LYNCH PIN	2
10	1 1/4 x 3/4" x 10ga. MACHINERY BUSHING	12
11	LIFT CYLINDER - RH	1
12	LIFT CYLINDER - LH	1
13	BUCKET CYLINDER	2
14	VALVE	1
15	FEEDLINE - TOP	1
16	FEEDLINE - 2nd	1
17	FEEDLINE - 3rd	1
18	FEEDLINE - BOTTOM	1
19	9/16 - 18 SWIVEL NUT 90° ELBOW	2
20	1/4 x 24" HYDRAULIC HOSE 9/16 - 18 ORB x3/8 MJIC	4
21	3/8 x 20" HYDRAULIC HOSE 9/16 - 18 ORB x3/8MS	1
22	1/4 x 16" HYDRAULIC HOSE 1/4 MP x318 MJIC	8
23	1/2" x 90" ST. ELBOW	1
24	1/2" VENT PLUG	1
25	1/2" PIPE END	1
26	3/8: x 90° ST. ELBOW	1
27	1/4" x 90° ST. ELBOW	4
28	#10 x 1/2" HEX HEAD SELF-TAPPING SCREW	1
29	1/4" - 28 UNF ST. GREASE ZERK	12
30	1/4 - 20 x 2" HEX HEAD CAPSCREW	2
31	1/4" LOCK WASHER	2
32	1/4" - 20 HEX NUT	2
33	DECAL - VALVE OPERATION	1
34	DECAL - HONDA	2
35	DECAL - WARNING - IMPROPER SERVICE	1
36	DECAL - WARNING - TRACTOR TIP OVER	1
37	DECAL - WARNING - LOADS CAN FALL	1
38	DECAL - NOTICE - LOADER HYDRAULIC SYSTEM	1
39	DECAL - SERVICE INFORMATION - SPECIAL ATTACHMENTS	1

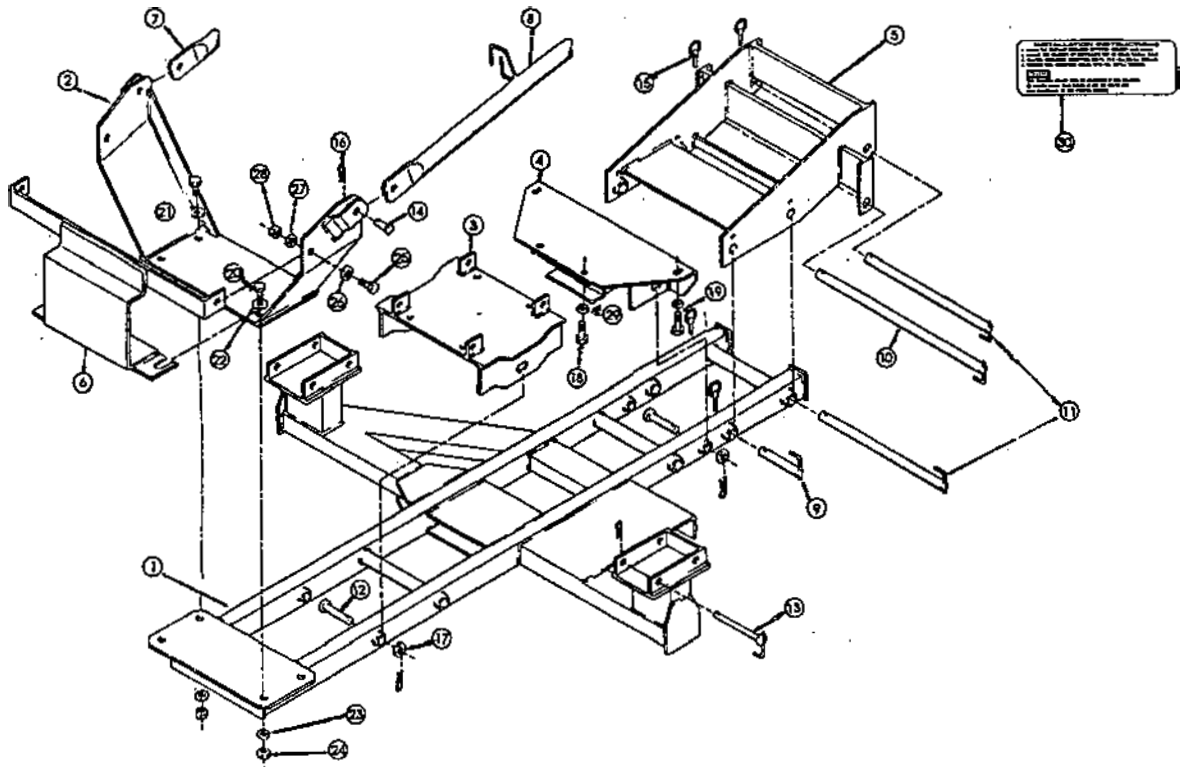

REPAIR PARTS — SUB-FRAME

REFERENCE NUMBER	DESCRIPTION	QUANTITY REQ'D
1	SUB FRAME	1
2	FRONT BRACKET	1
3	LOWER FRONT COVER, FRAME	1
4	BOTTOM BRACKET	1
5	WEIGHT BRACKET, COUNTERWEIGHTS	1
6	PUMP GUARD	1
7	BRACE ARM, RH	1
8	BRACE ARM, LH	1
9	PIN, COUNTERWEIGHT BRACKET A	2
10	PIN, COUNTERWEIGHT BRACKET B	1
11	PIN, COUNTERWEIGHT BRACKET C	2
12	PIN D, WITH FLAT (Mounting Pin)	4
13	PINE (Fixing Pin)	4
14	5/8 x 1 1/4" LEVIS PIN	4
15	7 1/6" LYNCH PIN	5
16	#11 CLIP PIN	12
17	1 1/4" x 3/4" x 10ga MACHINERY BUSHING	4
18	12x 25mm HEX HEAD CAPSCREW	2
19	10 x 30mm HEX HEAD CAPSCREW	2
20	1/2 - 13 x 1 3/4" HEX HEAD CAPSCREW	2
21	1/2 - 13 x 1 1/2" HEX HEAD CAPSCREW	2
22	1/2" FLATWASHER	6
23	1/2" LOCKWASHER	4
24	1/2" - 13 HEX NUT	4
25	7/16 - 14 X 1 1/4" HEX HEAD CAPSCREW	2
26	7/16" FLAT WASHER	2
27	7/16" LOCKWASHER	2
28	7/16"- 14 HEX NUT	2
29	3/8" FLATWASHER	2
30	DECAL - INSTALLATION	1

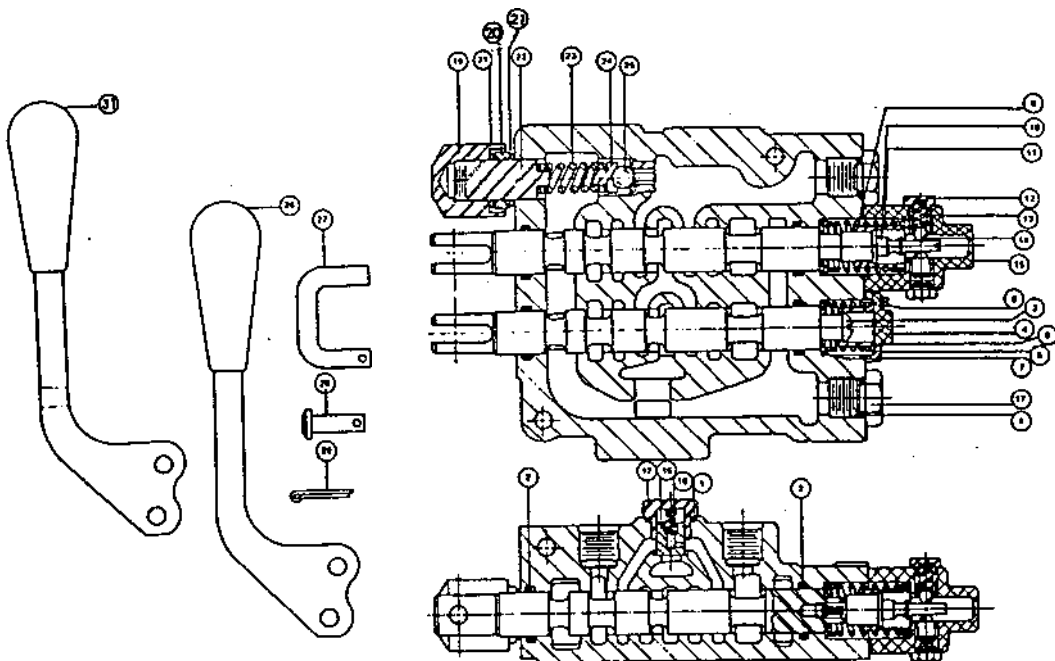

REPAIR PARTS.— HYDRAULIC VALVE

REFERENCE NUMBER	DESCRIPTION	QUANTITY REQ'D
1	O-RING	4
2	O-RING	4
3	SCREW	1
4	END CAP	1
5	RETURN SPRING	1
6	SPACER	1
7	WASHER	1
8	SCREW w/LOCKWASHER	2
9	SPACER	1
10	DETENT SPOOL	1
11	RETURN SPRING	1
12	DETENT PLUG	2
13	DETENT SPRING	2
14	STEEL BALL	2
15	DETENT END CAP	1
16	LOAD CHECK POPPET	1
17	LOAD CHECK PLUG	2
18	LOAD CHECK SPRING	1
19	TAMPER PROOF CAP	1
20	JAM NUT	1
21	GASKET	2
22	ADJUSTMENT SCREW	1
23	RELIEF SPRING	1
24	BALL RETAINER	1
25	STEEL BALL	1
26	HANDLE, STRAIGHT	1
27	C-HOOK	2
28	PIN	2
29	COITER PIN	4
30	HANDLE - BENT	1

WARRANTY SERVICE

OWNER SATISFACTION

Your satisfaction and good will are important to your dealer and to us. All Honda warranty details are explained in the Distributor's Limited Warranty. Normally any problems concerning the product will be handled by your dealer's service department. If you have a warranty problem that has not been handled to your satisfaction, we suggest you take the following action:

- Discuss your problem with a member of the dealership management. Often complaints can be quickly resolved at that level. If the problem has already been reviewed with the Service Manager, contact the owner of the dealership or the General Manager.
- If your problem still has not been resolved to your satisfaction, contact the Power Equipment Customer Relations Department of American Honda Motor Co., Inc.

American Honda Motor Co., Inc.
Power Equipment Customer Relations Department
P.O. Box 10021
Duluth, Georgia 30136-9421
Telephone: (770) 497-6400

We will need the following information to assist you:

- Your name, address, and telephone number
- Product model and serial number
- Date of purchase
- Dealer name and address
- Nature of problem

After reviewing all the facts involved, you will be advised of what action can be taken. Please bear in mind that your problem will likely be resolved at the dealership, using the dealer's facilities, equipment, and personnel, so it is very important that your initial contact be with the dealer.

Your purchase of a Honda product is greatly appreciated by both your dealer and American Honda Motor Co., Inc. We want to assist you in every way possible to assure your satisfaction with your purchase.

Current customer service contact information:

United States, Puerto Rico, and U.S. Virgin Islands:

Honda Power Equipment dealership personnel are trained professionals. They should be able to answer any question you may have. If you encounter a problem that your dealer does not solve to your satisfaction, please discuss it with the dealership's management. The Service Manager or General Manager can help. Almost all problems are solved in this way.

If you are dissatisfied with the decision made by the dealership's management, contact the Honda Power Equipment Customer Relations Office. You can write:

American Honda Motor Co., Inc.
Power Equipment Division
Customer Relations Office
4900 Marconi Drive
Alpharetta, GA 30005-8847

Or telephone: (770) 497-6400 M-F, 8:30 am - 5:00 pm EST

When you write or call, please provide the following information:

- Model and serial numbers
- Name of the dealer who sold the Honda power equipment to you
- Name and address of the dealer who services your equipment
- Date of purchase
- Your name, address, and telephone number
- A detailed description of the problem

HONDA

H/C 3752490



Printed on
Recycled Paper