



DIXON INDUSTRIES, INC. A  
BLOUNT COMPANY AIRPORT  
INDUSTRIAL PARK  
PO BOX 1569  
COFFEYVILLE KS 67337 0945  
316 251 2000  
FAX 316 251 4117



# TECHNICAL DATA

## ZTR Model 312

**IMPORTANT - READ OPERATOR'S MANUAL BEFORE OPERATING OR MAKING ADJUSTMENTS**

### SEAT ADJUSTMENT

1. Pull or lift body retention latch P/N 3934 from transaxle backing plate, raise and push body and seat assembly forward.
2. Loosen four seat adjustment knobs P/N 1849 and slide seat forward or backward to desired position.
3. Re-tighten seat adjustment knobs P/N 1849. DO NOT operate mower without seat adjustment knobs properly tightened.
4. Close upper body and push retention latch. P/N 3934 over transaxle backing plate.

## REMOVING THE BODY

1. The 312 has a two-piece polyethylene body. The upper body can be folded forward to expose the transaxle. In some cases, it may be necessary to remove the upper body to service the transaxle.
2. To remove upper body, remove two bolts P/N 3093 from the front of upper body hinge located on the brake shaft P/N 9283. Disconnect seat switch P/N 4761 at plug-in.
3. Reverse above procedure to reinstall.

## ADJUSTMENT OF MOWER DECK DRIVE BELT

1. This mower deck drive belt is tensioned by a spring loaded engagement Idler quadrant.
2. This system is designed to maintain the proper belt tension at all times.
3. Belt tension can be adjusted by moving the engaging rod P/N 7013 into the outside hole of engagement handle P/N 7020.
4. After belt tension is adjusted, check to assure that the mower blade will not turn freely when the engaging rod is in the "OFF" position.
5. If the mower blade turns freely, adjust the blade brake by loosening nut P/N 3205 at the end of the brake rod P/N 2988.
6. After adjustment is achieved, perform the safety checks listed below.

## REMOVING THE MOWER BLADE

Secure blade P/N 2483 from turning. Remove blade bolt from center of blade P/N 3268, and blade washer P/N 6260 then remove blade P/N 2483. To reinstall, reverse above procedure.

**WARNING:** Sharp edges on blade can cause injury!  
Caution should be exercised when service is required on blade.

## REMOVING THE MOWER DECK

1. Loosen belt keepers P/N 7026 & 7027 located under the engine by loosening two rear engine mounting bolts, allowing the deck drive belt to come free of the rear pulley.
2. Disconnect the wiring loom at the deck safety switch P/N 4242.
3. Remove the two clevis pins P/N 3072 from the two rear L-rods P/N 1355 and slide from slots.
4. Remove clevis pin P/N 3072 from L-rod attached to lift handle and slide from slot.
5. Remove clevis pin P/N 3072 from front deck hanger shaft P/N 1332, located at front of mower deck on slide plates welded at battery box, and remove.
6. Lift front of mower chassis clear of deck. Roll chassis free of the deck.
7. To install, reverse the above procedure.

## MOWER BLADE OPERATION

To engage mower blades, turn engagement lever on floor *slowly* to the "ON" position. To Disengage mower blades, turn lever *slowly* to the "OFF" position.

## SAFETY CHECKS

*IMPORTANT - PERFORM SAFETY CHECKS AFTER MAKING ANY REPAIRS OR ADJUSTMENTS*

1. After reassembly, while seated on mower, attempt to start engine with mower deck engaged. Engine should *not* start. If engine does start, return the mower to an Authorized Dixon dealer for adjustment or repair.
2. Disengage mower deck and start engine. With the operator In the normal seated position. , engage mower deck and remove weight from seat. The engine should stop. If the engine does *not* stop when operator rises from seat, return the mower to an Authorized Dixon dealer for adjustment or repair.
3. Engage then disengage mower blade in each cutting height. Insure that blade disengages and comes to a stop within (5) seconds in each height position. If blade does *not* disengage properly, contact your Authorized Dixon dealer.

**CAUTION: DO NOT OPERATE MOWER IF ANY SAFETY FEATURE IS NOT FUNCTIONING CORRECTLY**

## PARKING BRAKE ADJUSTMENT

Remove the body as described above. Tighten nut on brake rod P/N 2533 located In front of the transaxle on each side, just enough to prevent brake from slipping when engaged.

CAUTION: Over-tightening may cause premature wear on the brake band P/N 5085

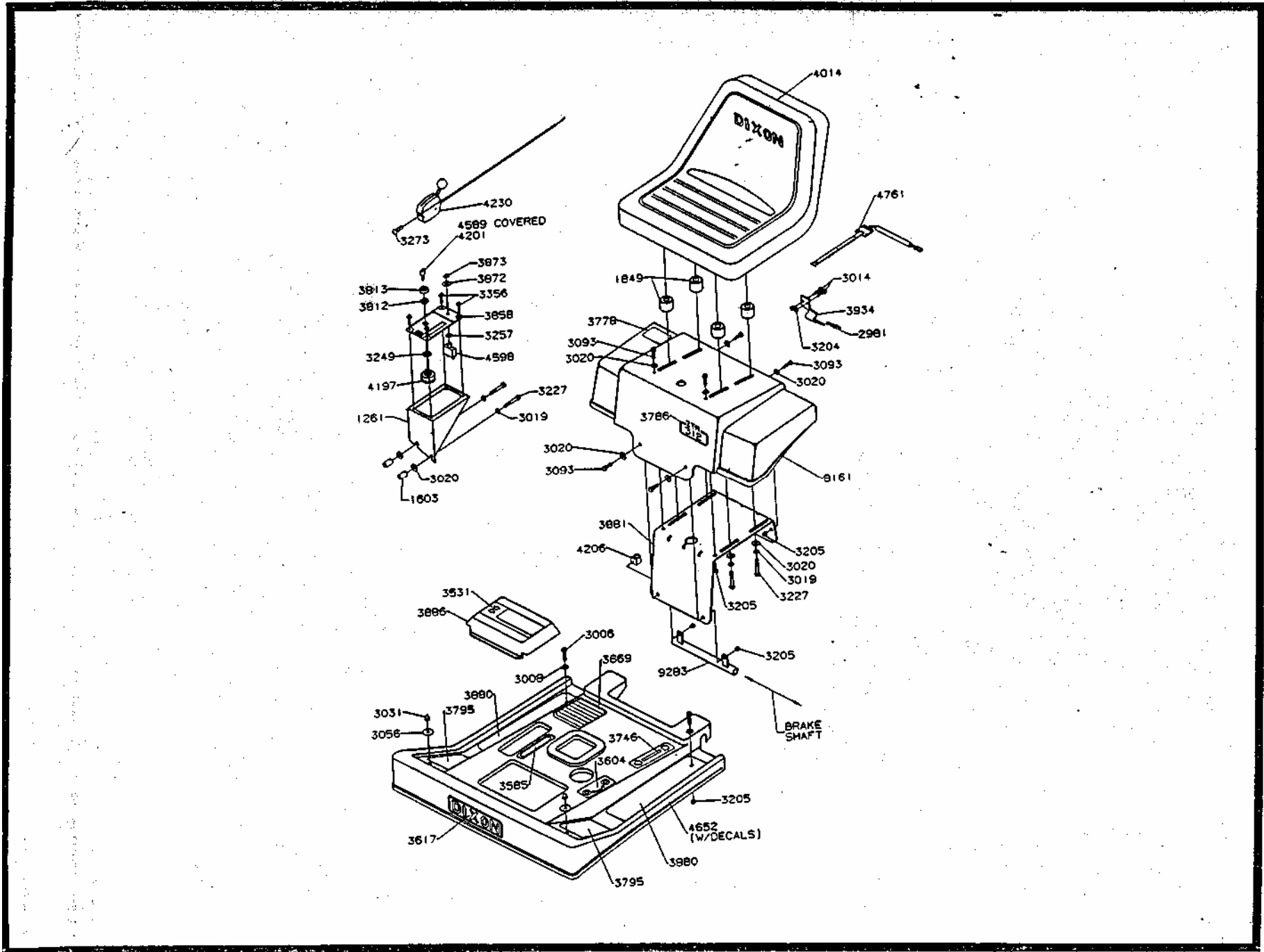

312 BODY ASSEMBLY



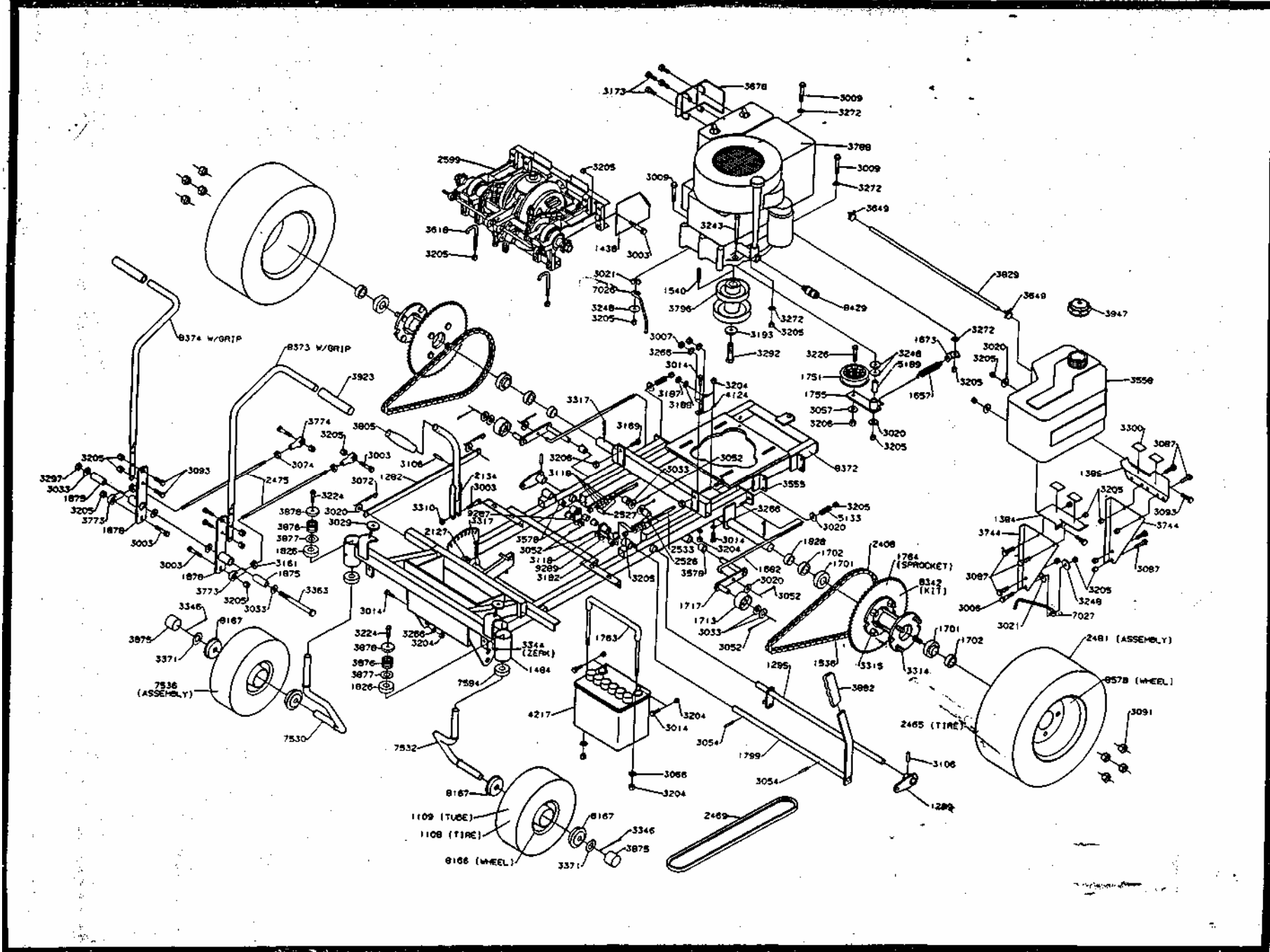

312 CHASSIS ASSEMBLY

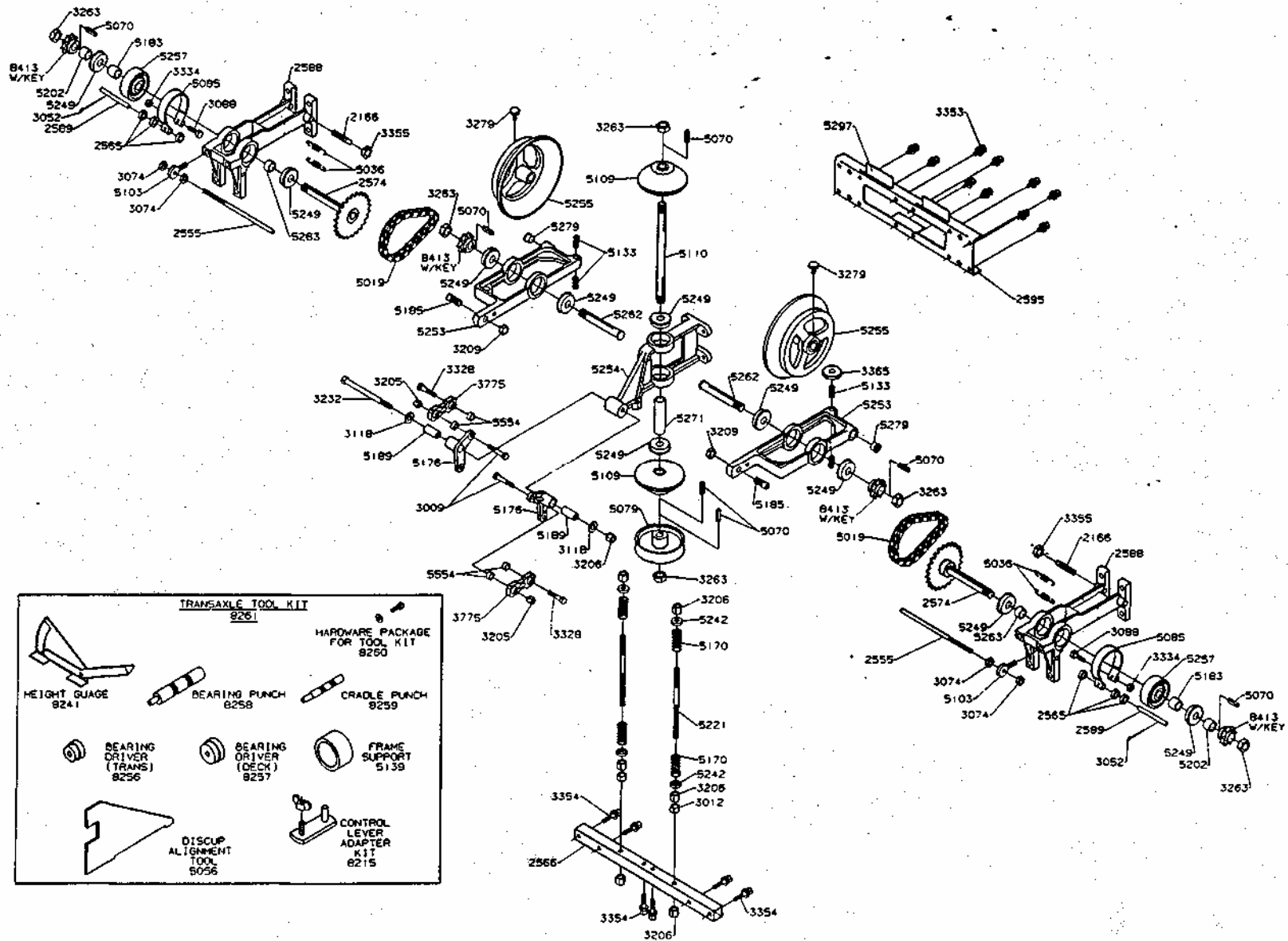

312 TRANSAXLE ASSEMBLY

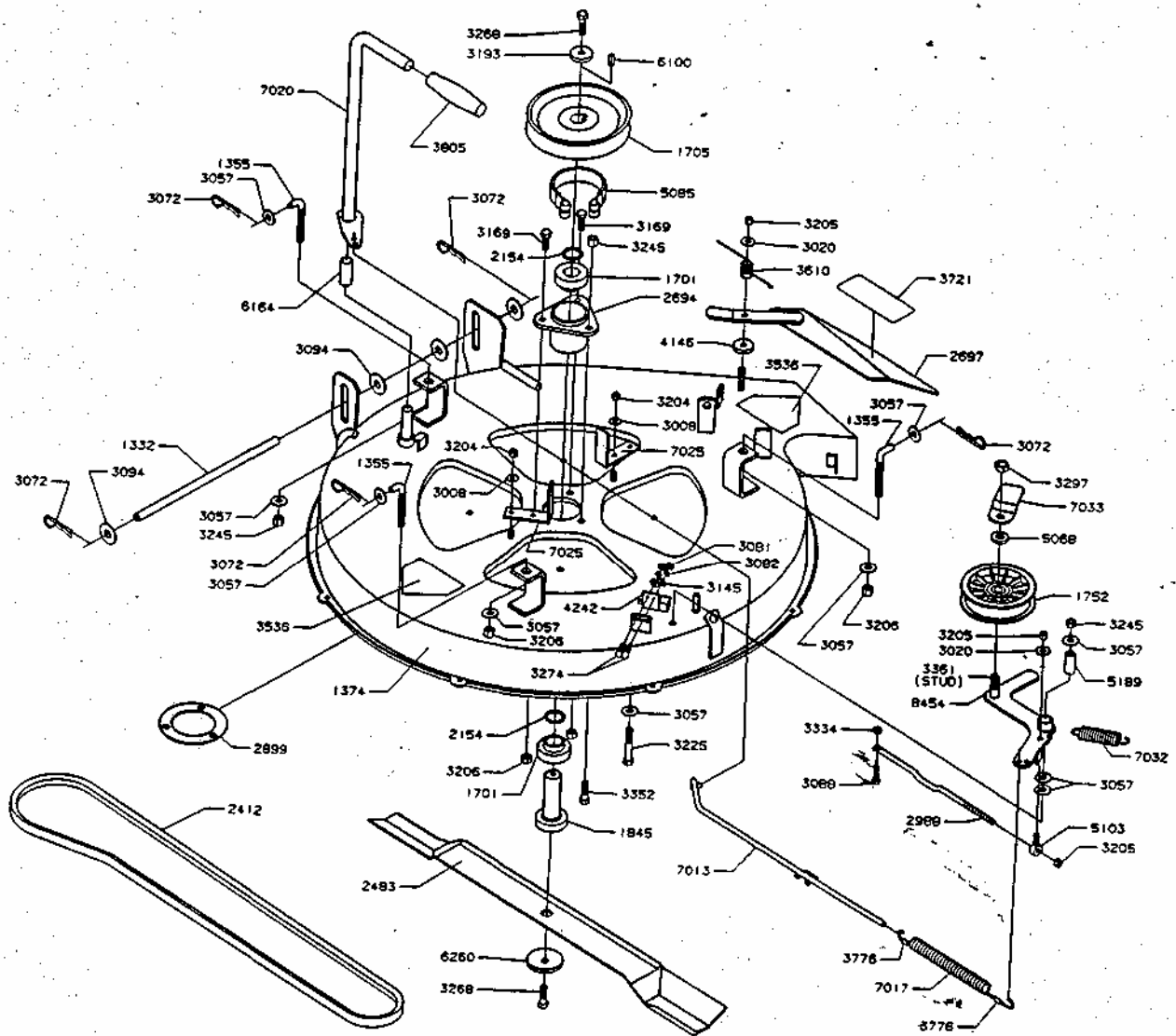

312 MOWER DECK ASSEMBLY - 1375



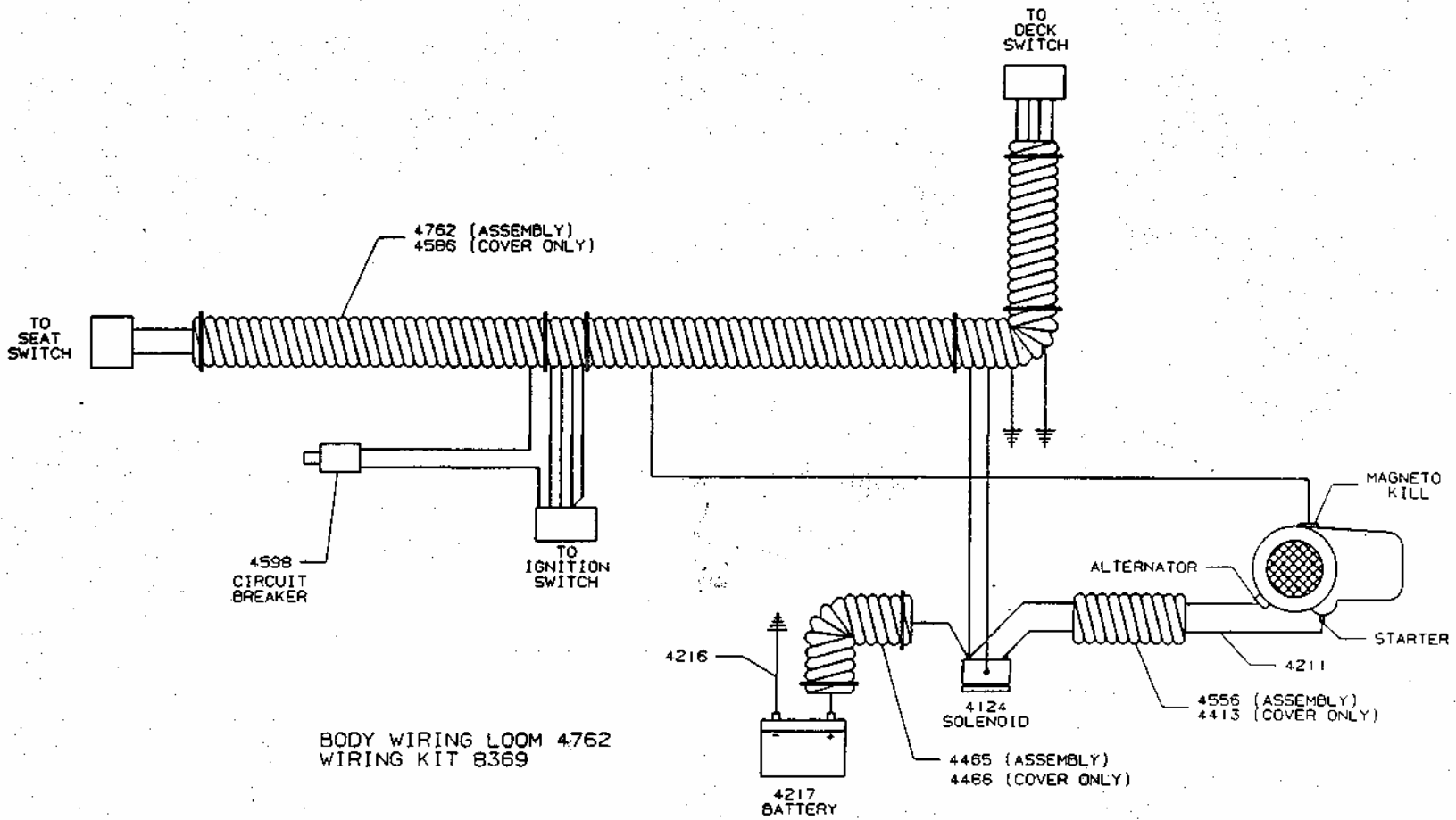

312 WIRING ASSEMBLY