

Parts Manual for

SNAPPER®

21" STEEL DECK WALK BEHIND MOWERS SERIES 20



Model No.	Description
7800428	2167520B
7800596	217020B
7800437	N2167520B
7800600	N217020B
7800438	NP2167520B
7800601	NP217020B
7800692	NP2187520
7800771	NP2187520
7800439	NP2187520BV
7800429	P2167520B
7800597	P217020B
7800554	P2187520
7800758	P2187520
7800842	P2172520B
7800430	P2187520BV
7800432	P2187520BVE
7800555	P2187520E
7800759	P2187520E
7800602	RP217020
7800424	RP217020BDV
7800845	RP2172520
7800754	RP2187520
7800425	RP2187520BV
7800552	RP2187520
7800492	RP2187520BV2N1
7800427	RP2187520BVE
7800553	RP2187520E

Briggs & Stratton Yard Power Products Group

535 Macon Road
McDonough, GA, 30253 U.S.A.
800-935-2967

Manual No. 7006477

Revision: G 10/28/2011

Not for
Reproduction

PAGE	GROUP
4	Handles & Controls
8	Engine, Cutting Deck & Blade
10	Wheels Front and Rear
12	Wheel Brackets & Latches (Push)
14	Wheel Brackets & Latches (Self-Propelled)
16	Drive System Self-Propelled
20	Transmission (Differential)
22	Decals
24	Side Chute, Adapter
26	Grass Bag Components
28	Accessory Recycling Kits
30	Accessory Snapperizer
32	Electric Start Components

Not for
Reproduction

Handles & Controls

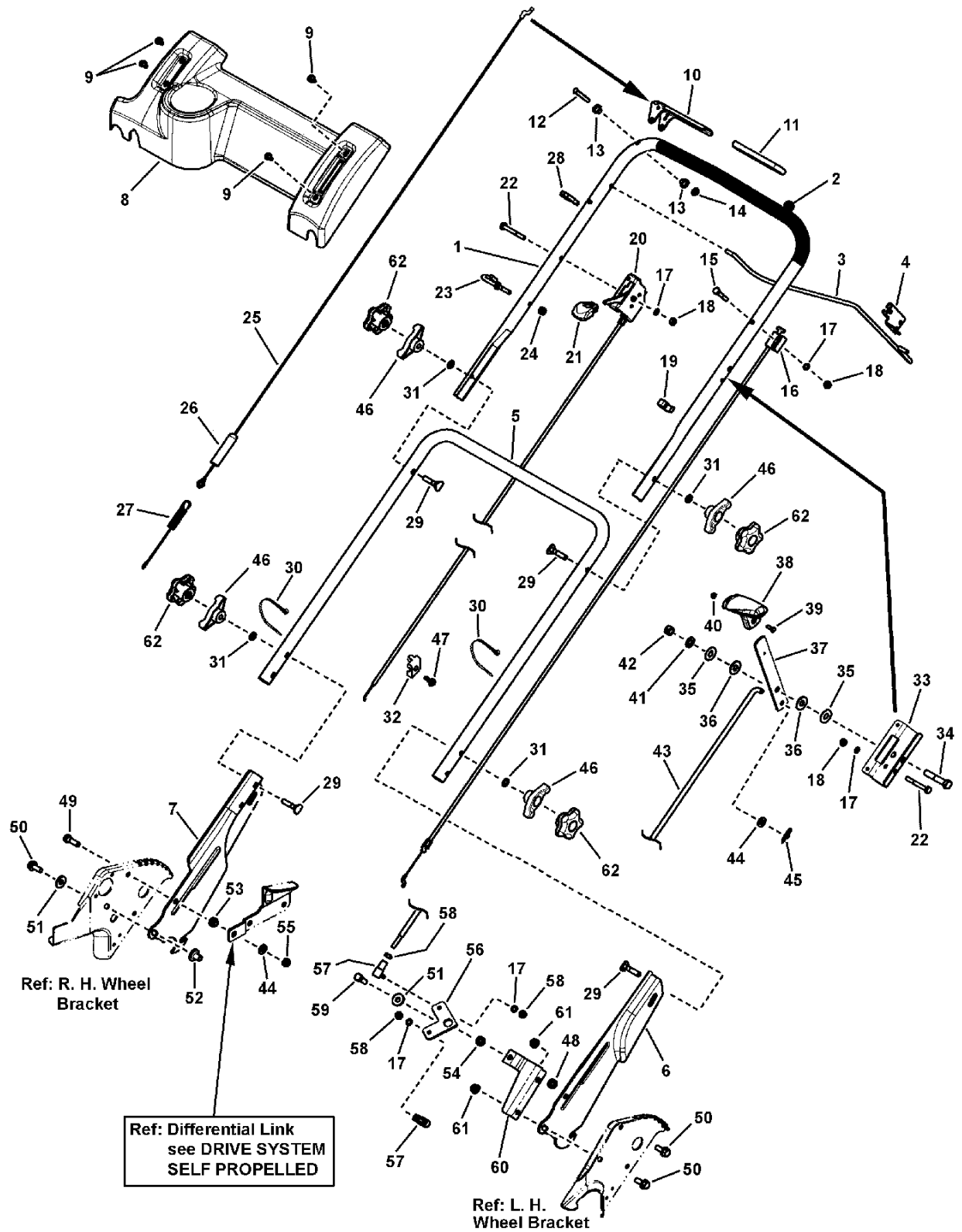

Item	Part No	Qty	Description
1	7074411	1	HANDLE, Upper
2	7023810	1	FOAM GRIP, 18.75 long
3	7074418	1	BAIL, OPC Control
4	7034872	1	CLIP, Zone Control
5	7074156	1	HANDLE, Middle
6	7033985	1	HANDLE, Lower LH (Adjustable)
7	7033986	1	HANDLE, Lower RH (Adjustable)
8	7074140	1	CONTROL PANEL (w/o Electrical Switch Hole) (Used on Manual Start Models)
8	7074469	1	CONTROL PANEL (w/Electrical Switch Hole) (Used on Electric Start models)
8	7073826	1	CONTROL PANEL (w/o wheel drive slot) (used on 7800428 & 7800437)
9	7091200	4	SCREW, 1/4-20 x 1/2 Pan Head Self-Tap (Torx)
10	7074473	1	HANDLE, Clutch
11	7028407	1	GRIP, International Symbol
12	7023792	1	PIN, 1/4 x 1-1/2"
13	7014343	2	BUSHING, .27 x .35 x .4 Flange
14	7091020	1	PUSH-NUT, 1/4"
15	7079577	1	SCREW, 1/4-20 x 1-1/2 Hex Head Cap GR 5
16	7034608	1	* CABLE, Zone Control (52-63/64 Long) (used on 7800425, 7800428, 7800429, 7800437, 7800596, 7800597 & 7800602)
16	7102593	1	* CABLE, Zone Control (52-21/32 Long) (used on 7800424, 7800552, 7800553, 7800554, 7800555, 7800754, 7800758, 7800759 & 7800771)
16	7078078	1	* CABLE, Zone Control (50-31/64 Long) (used on 7800427 & 7800432 models only)
17	7090053	5	WASHER, 1/4 Internal Tooth Lock (was 7091023)
18	7091576	3	NUT, 1/4-20 Hex (was 7091100)
19	7023813	1	CLIP, Wiring Harness
20	7074460	1	THROTTLE CONTROL, (48.5) (used on all models except for those shown below)
20	7100975	1	THROTTLE CONTROL, RP, D.O.V. Engine (50.0) (used on 7800424 model)
20	7102594	1	THROTTLE CONTROL, (62.0) (used on 7800552, 7800554, 7800555, 7800553, 7800754, 7800758, 7800759 & 7800771)
21	7075308	1	THROTTLE KNOB, (Red)
22	7090505	2	SCREW, 1/4-20 x 2 Hex Head Cap, GR 5
23	7028488	1	GUIDE, Rope (1/4-20 thread)
24	7076978	1	NUT, 1/4-28 Hex GR 5 or B
25	7034604	1	CABLE, Clutch Control (41-1/4 Long)
26	7012121	1	COVER, Vinyl
27	7012122	1	SPRING, Clutch - 21S
28	7026219	1	CLAMP, 7/8 Double Cable
29	7091189	4	SCREW, 5/16-18 x 1-7/8 Curved Head GR 2 (was 7091740)
30	7012080	2	CABLE-TIE, 7"
31	7090391	4	WASHER, 5/16 Internal Tooth Lock
32	7023153	1	CLAMP, Casing
33	7074003	1	BRACKET, Shift
34	7091305	1	SCREW, 3/8-16 x 2 Hex Head Cap, GR 5
35	7031961	2	WASHER, 7/16 Flat
36	7028465	2	WASHER, Nylon
37	7074113	1	LEVER, Shift

Footnotes:

NOTE: * Part number and revision is stamped on cable.

Handles & Controls

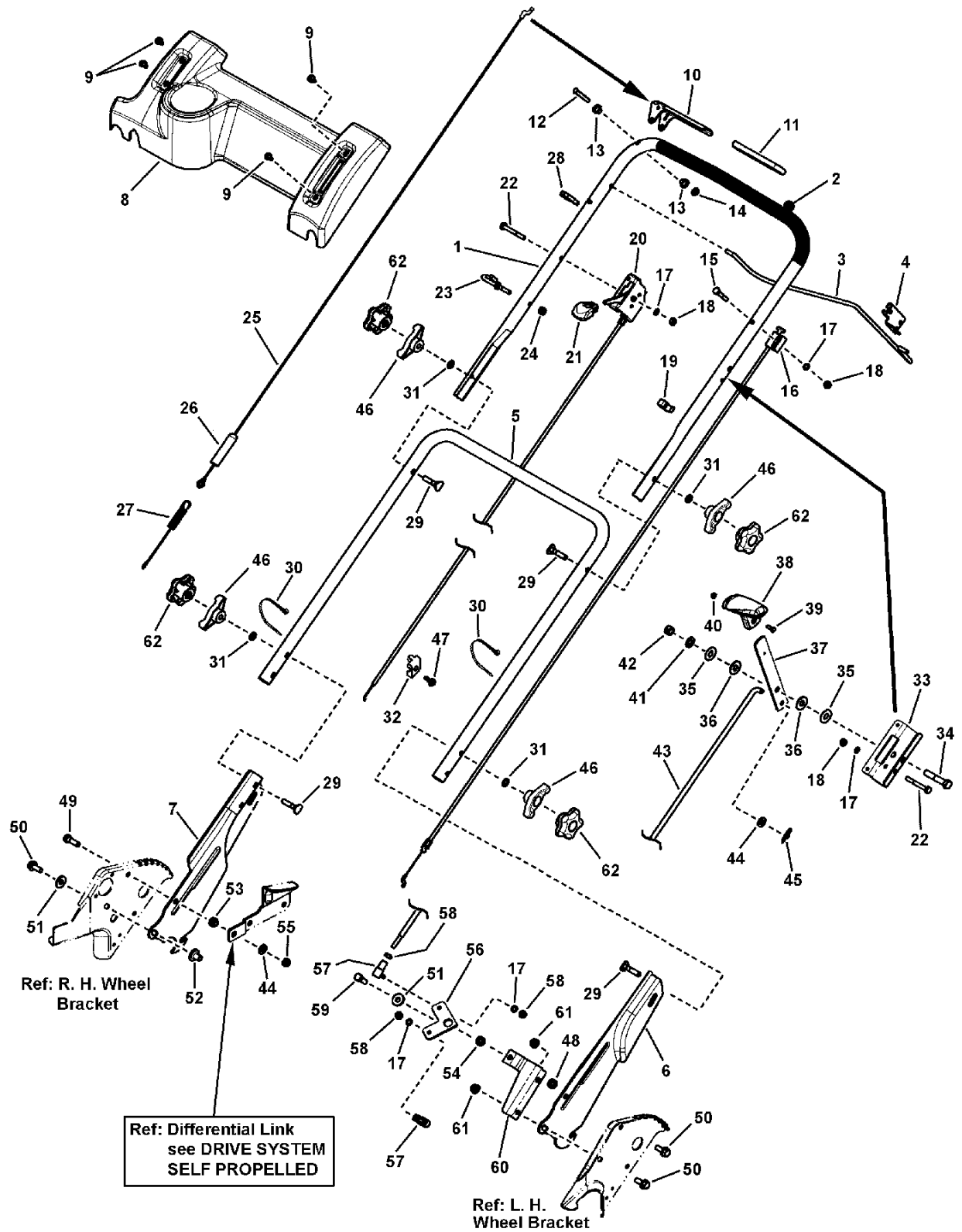

Item	Part No	Qty	Description
38	7075182	1	KNOB, Shift (Red)
39	7091167	1	SCREW, #8-32 x 1/2 Cross Recess Filister Head Machine
40	7091018	1	NUT, #8-32 Hex
41	7028568	1	WASHER, Belleville
42	7091585	1	NUT, 3/8-16 Hex Center Lock
43	7074133	1	ROD, Speed Control (1/4-28 thread)
44	7090188	2	WASHER, 11/32 Flat
45	7034162	1	COTTER PIN, 5/16 Self Lock
46	7035744	4	KNOB, 5/16-18 Wing (Black) (was 720727)
47	7023154	1	SCREW, #10-32 x 5/8 Self-Tap
48	7091575	1	NUT, 5/16-18 Hex Center Lock (was 7091067)
49	7090238	1	SCREW, 5/16-24 x 1 Hex Head Cap GR 5
50	7090595	3	BOLT, 5/16-18 x 3/4 Hex Flange Lock GR 5
51	7091130	2	WASHER, .33 x .88 x .09 Flat
52	7090538	1	TEENUT, 5/16-18 (or 7090895)
53	7012114	1	BUSHING, Differential, .328 x .625 x .41
54	7013849	1	SPACER, .33 x .63 x .156
55	7091606	1	NUT, 5/16-24 Hex Center Lock GR 5 (was 7091074)
56	7073913	1	BELL CRANK
57	7015753	2	BALL JOINT, 1/4-28
58	7090095	3	NUT, 1/4-28 Hex
59	7091904	1	SCREW, 5/16-18 x 7/8 Hex Head Cap, GR 5
60	7073822	1	BRACKET, Bell Crank
61	7091601	2	NUT, 5/16-18 Hex Flange Lock, GR 5 (was 7090585 or 7091070)
62	7105085	4	KNOB, Handle, 5-Prong

Footnotes:

NOTE: * Part number and revision is stamped on cable.

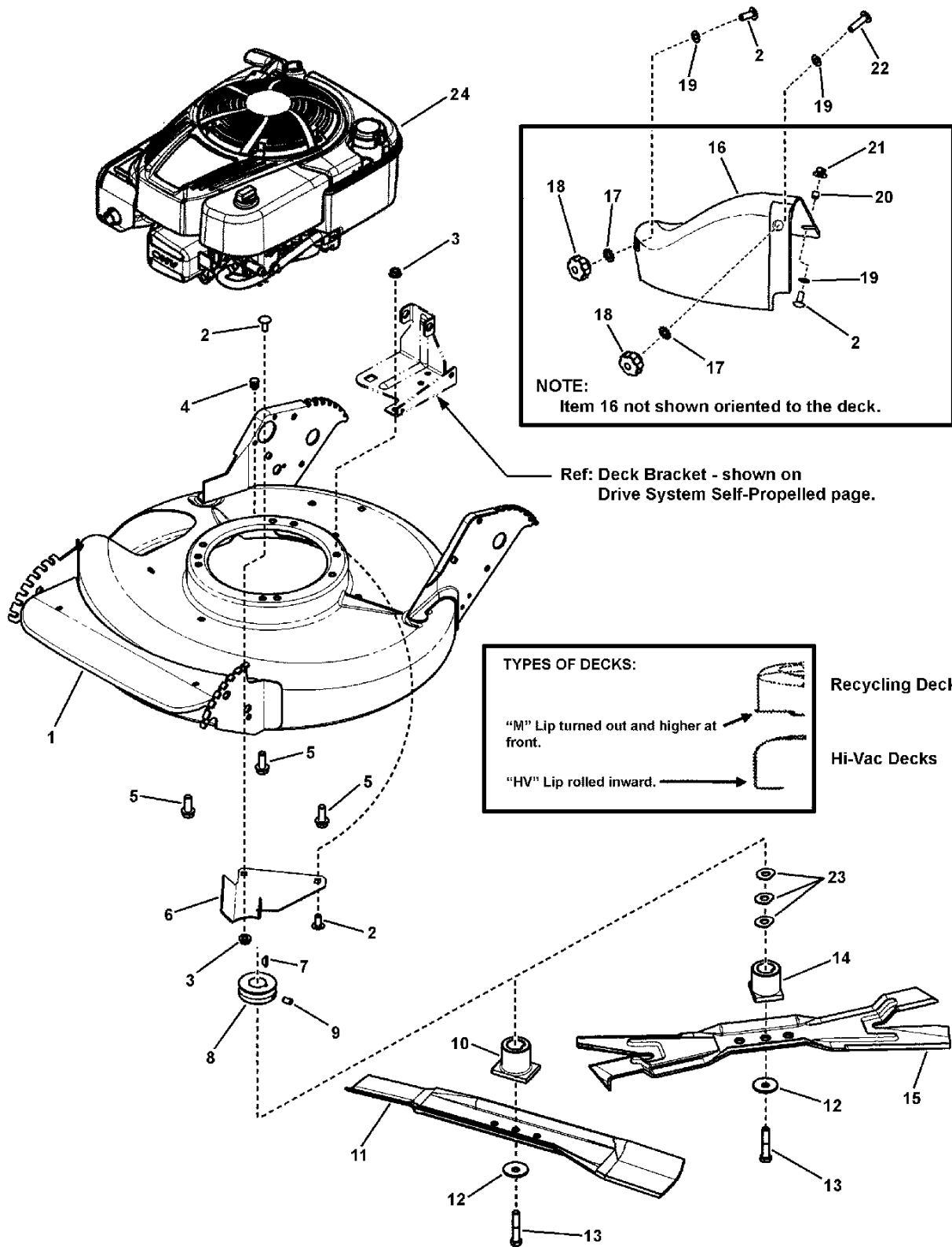

Item	Part No	Qty	Description
1	7500081	1	WELDMENT, Deck, 21 Non-Adjust Air (red, w/o decals) (used on R (recycling) models)
1	7400029	1	WELDMENT, Deck, 21 Push, HV, Core Model (red, w/o decals) (used on 7800428 & 7800437 (push) models)
1	7500549	1	WELDMENT, Deck, Part Sales, Hi-Vac, ES (red, w/decals) (used on self-propelled (non-recycling) models)
2	7091508	1	BOLT, 5/16-18 x 3/4 Short Neck Carriage GR 5 (was 7090001)
3	7091601	2	NUT, 5/16-18 Hex Flange Lock, GR 5 (was 7091070)
4	7046780	2	PLUG, Hole, Polyethylene
5	7090324	3	SCREW, 3/8-16 x 1 Self-Tapping (engine mount bolts)
6	7074568	1	COVER, Belt
7	7091214	1	KEY, Woodruff #HP-506 Hi-Pro
8	7015780	1	PULLEY, Engine (25mm I. D. x 2-1/8 O.D.)
9	7090201	1	SET SCREW, 5/16-18 x 5/16 Hex Socket (or 7092086 (SET SCREW, 5/16-18 x 1/2 Hex Recess))
10	7101414	1	HUB, Blade, 21 WBM, RD, 2 Position
11	7026691	1	BLADE, 21 Standard Lift
12	7012063	2	WASHER, Cone 3/8"
13	7090167	1	SCREW, 3/8-24 x 2 Hex Head Cap, GR 5
14	7015626	1	HUB, Blade Drive, 25 mm I.D.
15	7026407	1	BLADE, 21 Ninja (Quad Edge) (Used on Recycling Models)
16	7029149	1	COVER, 21 Deck
17	7090189	2	WASHER, 5/16 Internal/External Lock
18	7101022	2	KNOB, Fluted, 5/16-18 x 1/2"
19	7011791	1	RETAINER, 5/16 Bolt
20	7024340	1	SPACER, .316 ID x .375 OD x .310 thick
21	7090951	1	NUT, 5/16-18 Hex Large Flange Center Lock
22	7091169	1	BOLT, 5/16-18 x 1-1/8 Round Head Short Square Neck, GR 5, ZP
23	7044770	3	SPACER, Blade Hub (Used on 7800427 & 7800553)
24	100602-0155-B8	1	* ENGINE, B&S DOV 700 Series (used on 7800424 (RP217020BDV))
24	121Q72-0110-F1	1	* ENGINE, B&S 875 Professional Series, California Compliant (used on 7800692 (NP2187520))
24	126L02-4113-F1	1	* ENGINE, B&S 675 Series (used on 7800437 & 7800438)
24	126T02-0267-B1	1	* ENGINE, B&S 675 Series (used on 7800428 & 7800429)
24	128L02-0114-F1	1	* ENGINE, B&S 700 Series, California Compliant (used on 7800600 & 7800601)
24	12S502-0112-B1	1	* ENGINE, B&S 875 Series, Intek (used on 7800425, 7800430 & 7800492)
24	12S507-0115-B1	1	* ENGINE, B&S 875 Series, Intek (used on 7800432 & 7800427)
24	12S602-0110-F1	1	* ENGINE, B&S 875 Series, Snapper, XIC, F1 (used on 78000439 (NP2187520BV))
24	12S902-0126-B1	1	* ENGINE, B&S 875 Series, W14 (used on 7800552 & 7800554)
24	12S907-0127-B1	1	* ENGINE, B&S 875 Series, W14, ES (used on 7800553 & 7800555)
24	12S972-0152-B1	1	* ENGINE, B&S, 875 Series, W14 w/oil fltr, 49 ST (used on 7800754 & 7800758)
24	12S977-0153-B1	1	* ENGINE, B&S, 875 Series, W14 w/oil fltr (used on 7800759)
24	121S72-0111-F1	1	* ENGINE, 875 Series, Snapper California Compliant (used on 7800771)
24	128M02-0412-F1	1	* ENGINE, B&S, 725 Series, Snapper, 50 ST/FC (used on 7800842 & 7800845)

Footnotes:

NOTE: * Purchase engine parts from engine manufacturer dealer.

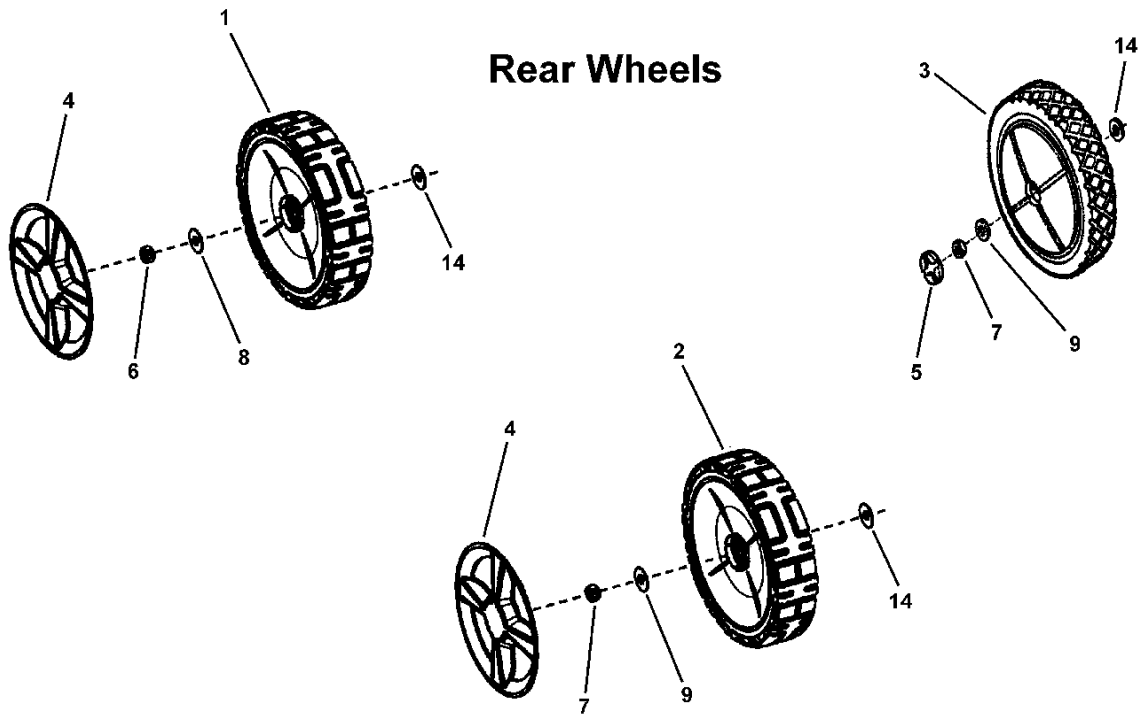

NOTE: Always replace wheel nut (item 6 or 7) when removing or replacing wheel.

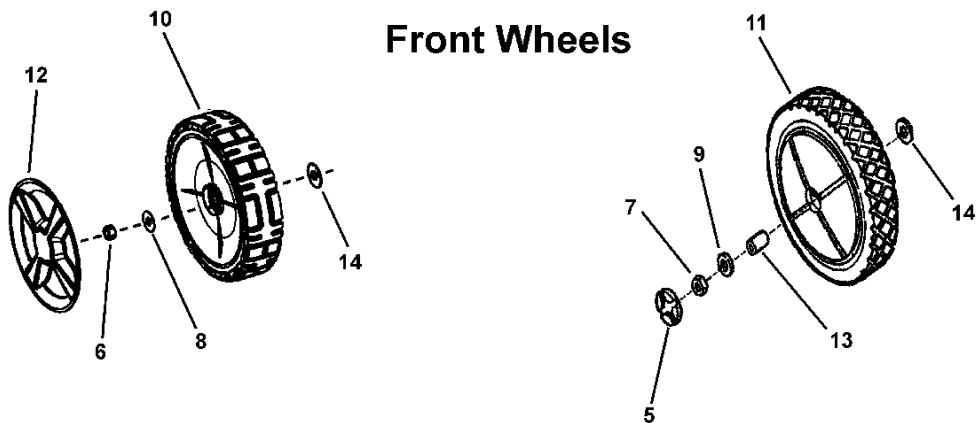

Item	Part No	Qty	Description
1	7501092	2	ASSY, Wheel, 10 x 2" Idle, BB, Snapper Tread (push) (incl. two 1-1/8" O.D. Flanged Ball Bearings (p/n 7101380))
2	7501078	2	ASSY, Wheel, 10 x 2" Drive w/metal insert Snapper Tread (used on all self-propelled models except RP2187520BVE)
3	7029011	2	WHEEL, 10 x 1.75" Plastic (self-propelled) (used on RP2187520BVE (7800427))
4	7102625	2	HUBCAP, 10" Wheel, Spoked- Snapper Cool Gray
5	7017829	4	PLUG, Wheel
6	7091585	2	NUT, 3/8-16 Hex Center Lock
7	7090377	4	NUT, 7/16-20 Hex Center Lock Jam
8	722604	2	WASHER, .387 x 1" O.O. Flat
9	7031961	2	WASHER, 7/16" Flat
10	7500540	2	ASSY, Wheel, 8 x 2" Idle, Snapper Tread, Charcoal Gray (incl. two 1-1/8" O.D. Flanged Ball Bearings (p/n 7101380))
11	7029010	2	WHEEL, 8 x 1.75" Plastic (used on RP2187520BVE (7800427) only)
12	7101350	2	HUBCAP, 8" Wheel, Spoked- Snapper Cool Gray (used on 7500540 wheel)
13	7012309	2	BUSHING, Axle
14	7100585	4	WASHER, Shim, .875 x .531 x .060 (qty. 2 on self-propelled)

Not for
Reproduction

Footnotes:

Wheel Brackets & Latches (Push)

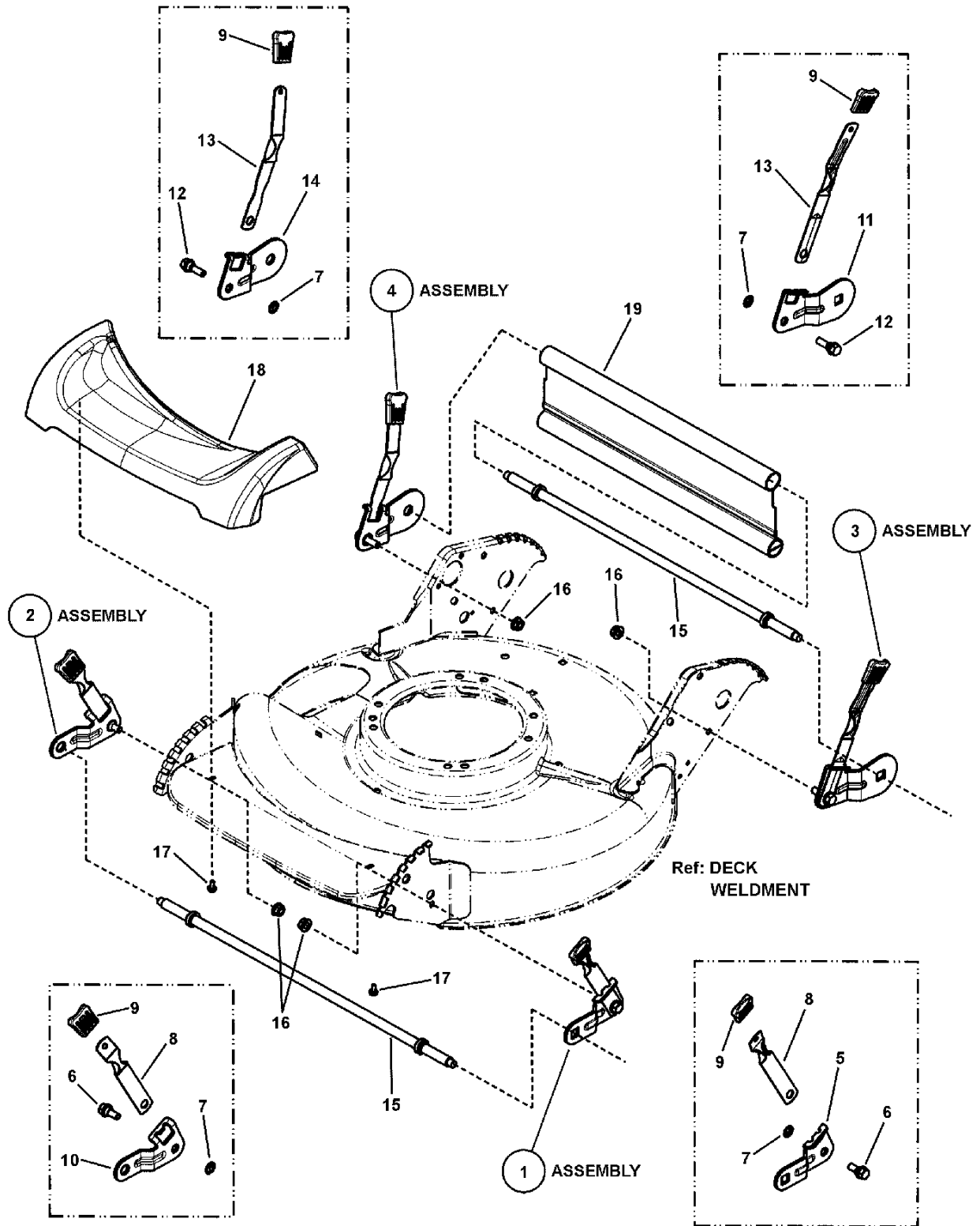

Wheel Brackets & Latches (Push)

Item	Part No	Qty	Description
1	7500038	1	ASSEMBLY, Left Wheel Arm (.512" Square Hole)
2	7051886	1	ASSEMBLY, Right Wheel Arm
3	7501119	1	ASSEMBLY, Wheel Arm, Left Rear Long (Push)
4	7054228	1	ASSEMBLY, Wheel Arm, Right Rear (Push)
5	7011393	1	WHEEL ARM, L.H. Front (.512" Square Hole)
6	7015761	2	BOLT, 5/16-18 x 3/4" Hex Washer Face Shoulder
7	7011791	4	RETAINER, 5/16" Bolt
8	7012325	2	LATCH, Height
9	7100633	4	GRIP, Height Latch
10	7031017	1	WHEEL ARM, R.H. Front (Round Hole)
11	7102587	1	ARM, Wheel, Left Rear
12	7011078	2	BOLT, 5/16-18 x 1" Hex Washer Face Shoulder
13	7035717	2	LATCH, Height Adjusting (long)
14	7033776	1	ARM, Wheel, Right Rear
15	7100752	2	AXLE, Front, Easy Line (3/8-16 Threads)
16	7091601	4	NUT, 5/16-18 Hex Flange Lock, GR 5 (was 7090585 or 7091070)
17	7900018	2	SCREW, Round Washer Head Torx, Hi-Lo
18	7100196	1	COVER, Front 21" walk
19	7103210	1	GUARD, Rear (21 Push)

Not for
Reproduction

Footnotes:

Wheel Brackets & Latches (Self-Propelled)

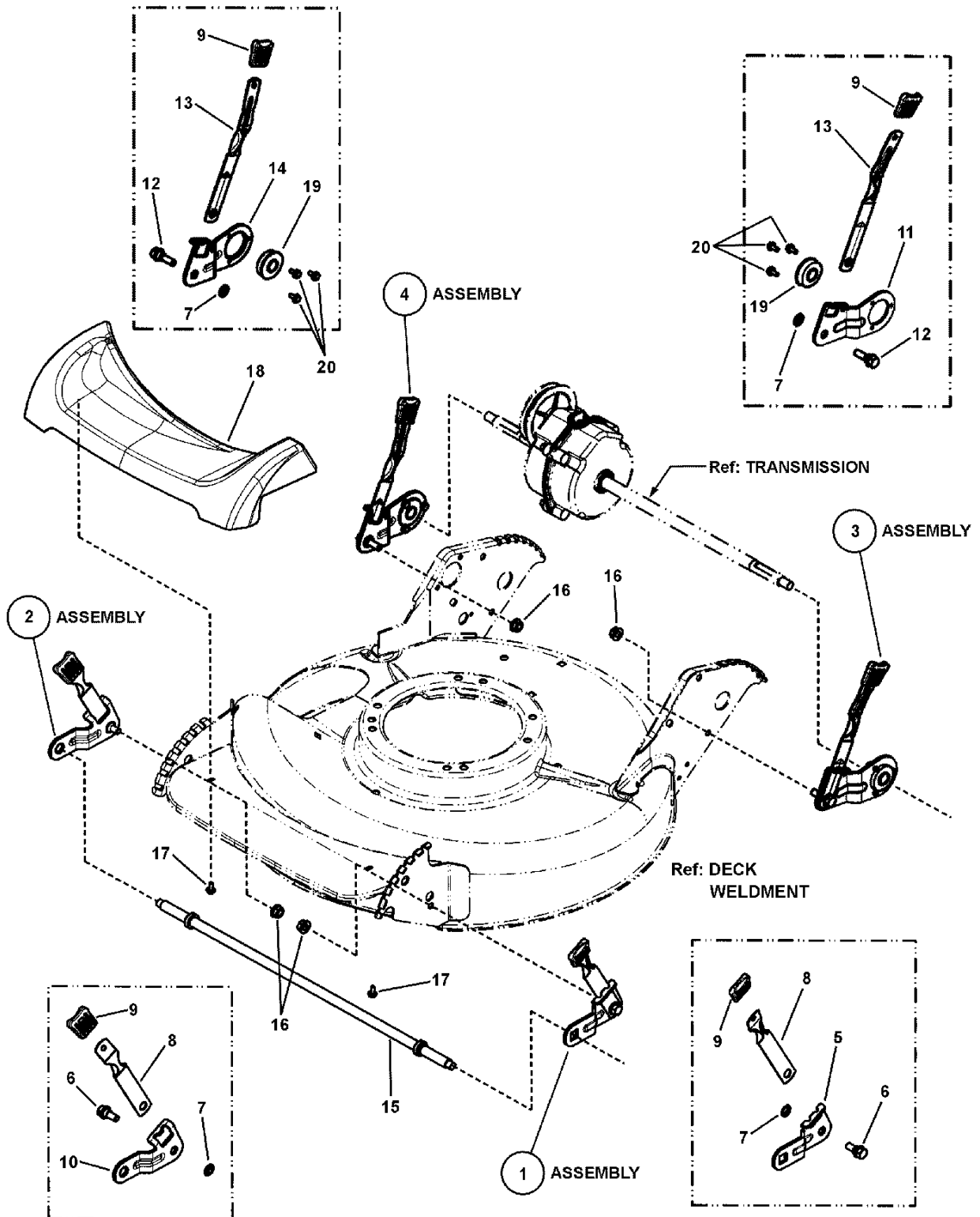

Wheel Brackets & Latches (Self-Propelled)

Item	Part No	Qty	Description
1	7500038	1	ASSEMBLY, Front Left Wheel Arm (.512" Square Hole)
1	7051885	1	ASSEMBLY, Front Left Wheel Arm (.453" Square Hole) (used on 7800427 only)
2	7051886	1	ASSEMBLY, Front Right Wheel Arm
3	7054247	1	ASSEMBLY, Wheel Arm Left Rear Long SP21S
4	7054246	1	ASSEMBLY, Wheel Arm, Right Rear (S.P.)
5	7011393	1	WHEEL ARM, L.H. Front (.512" Square Hole)
5	7031016	1	WHEEL ARM, L.H. Front (.453" Square Hole) (used on 7800427 only)
6	7015761	2	BOLT, 5/16-18 x 3/4" Hex Washer Face Shoulder
7	7011791	4	RETAINER, 5/16" Bolt
8	7012325	2	LATCH, Height
9	7100633	4	GRIP, Height Latch
10	7031017	1	WHEEL ARM, R.H. Front (Round Hole)
11	7032723	1	ARM, Wheel, Left Rear
12	7011078	2	BOLT, 5/16-18 x 1" Hex Washer Face Shoulder
13	7035717	2	LATCH, Height Adjusting (long)
14	7032722	1	ARM, Wheel, Right Rear
15	7100752	1	AXLE, Front, Easy Line (3/8-16 Threads)
15	7021119	1	AXLE, Front, (7/16-20 Threads) (used on 7800427 only)
16	7091601	4	NUT, 5/16-18 Hex Flange Lock, GR 5 (was 7090585 or 7091070)
17	7900018	2	SCREW, Round Washer Head Torx, Hi-Lo
18	7100196	1	COVER, Front 21" walk
19	7012312	2	BEARING, 9/16" I.D.
20	7091012	6	SCREW, #10-32 x 3/8" Hex Washer Self-Tap

Footnotes:

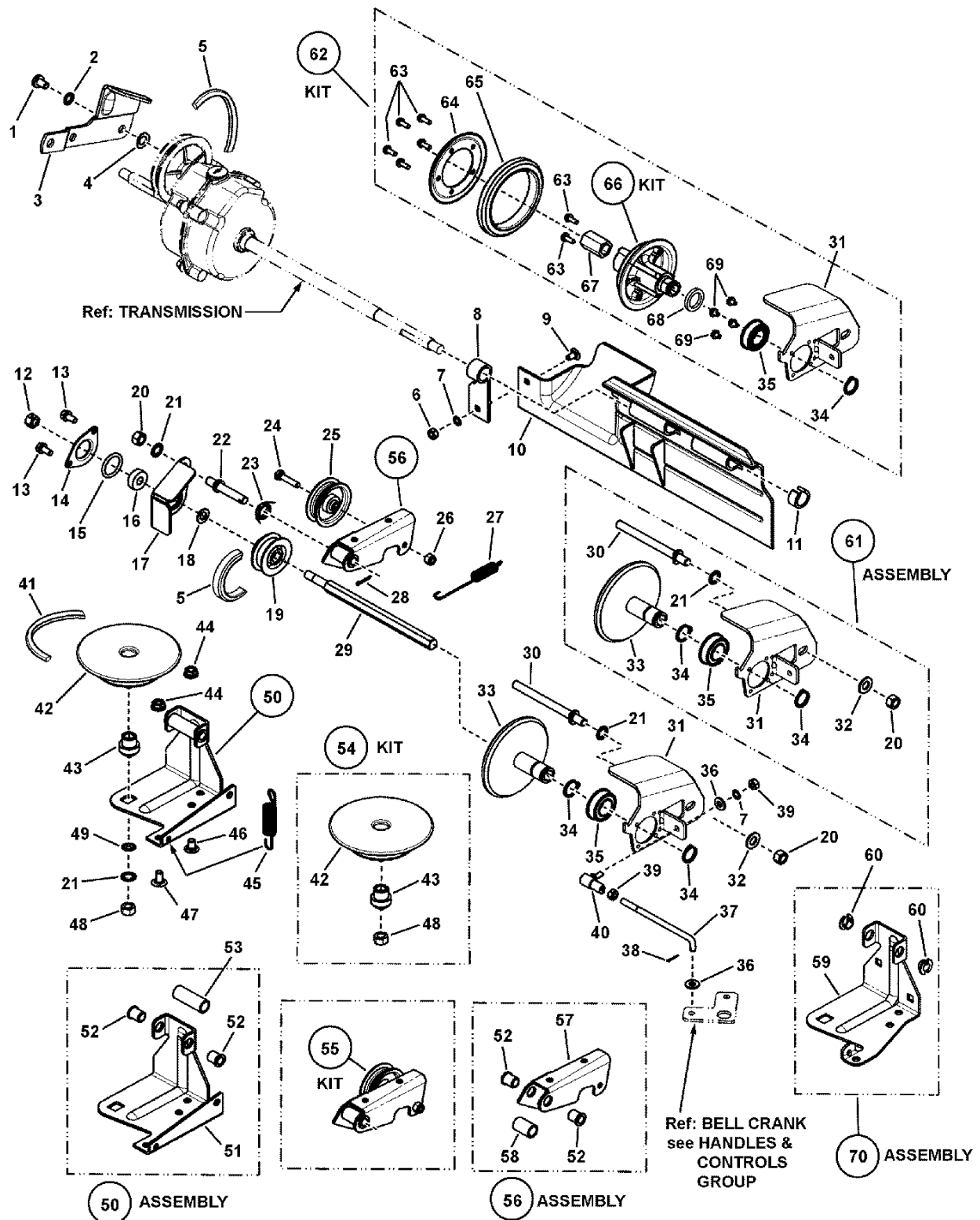

Item	Part No	Qty	Description
1	7091542	1	SCREW, 5/16-18 x 1/2" Pan Head Self-Tap (Torx)
2	7090391	1	WASHER, 5/16" Internal Tooth Lock
3	7034179A	1	LINK, Differential (Comm.)
4	7011724	1	WASHER, 44 x .78 x .025 Curved
5	7012354	1	BELT, Poly-V
6	7091576	1	NUT, 1/4-20 Hex, GR 5 (was 7090063)
7	7090053	1	WASHER, 1/4" Internal Tooth Lock (was 7091023)
8	7012616	1	SUPPORT, Foot Guard
9	7091604	1	BOLT, 1/4-20 x 1/2" Short Neck Carriage GR 5 (was 7090005)
10	7029008	1	FOOT GUARD, Rear
11	7023791	1	RING, Split (Black)
12	7090289	1	NUT, 3/8-24 Hex Center Lock, GR 5
13	7091122	2	SCREW, 1/4-20 x 1/2" Hex Flange Self-Tap (was 7090539)
14	7031809	1	HOLDER, Bearing (Outer Half)
15	7011025	1	O-RING, V21
16	7028014	1	BALL BEARING, Spherical O.D., .38 I.D.
17	7031873	1	HOLDER, Bearing (Inner Half)
18	7012316	1	WASHER, .390 I.D. Flat
19	7024521	1	PULLEY, Poly-V (2" O.D.)
20	7091630	2	NUT, 3/8-24 Hex
21	7090390	3	WASHER, 3/8" Internal Tooth Lock
22	7012111	1	STUD, Idler (3/8-24 thread)
23	7012126	1	SPRING, Idler- Torsion
24	7091025	1	SCREW, 1/4-28 x 1-3/8" Hex Head Cap, GR 5
25	7012124	1	PULLEY, Idler, V21
26	7090303	1	NUT, 1/4-28 Hex Top Lock
27	7012122	1	SPRING, Clutch - 21S
28	7091597	1	COTTER PIN, 3/32 x 1/2" (was 7090555)
29	7072284	1	SHAFT, Hex Drive
30	7012125	1	GUIDE, Thrust Plate (3/8-24 thread)
31	7300977A	1	THRUST PLATE, Short (was 7034281)
32	7090122	1	WASHER, 3/8" Flat
33	7041855	1	DISC, Driven (Cantilever) (ref: 7074139, Driven Disc Ass'y)
34	7010746	2	RETAINING RING, .625 External
35	7026693	1	BALL BEARING, 3/4" Bore (was 7029027)
36	7091294	1	WASHER, .28 x .63 x .06 Flat
37	7074145	1	LINK, Transfer (1/4-28 thread)
38	7090673	1	COTTER PIN, .06 x .50 YZ (was 7091629)
39	7090095	2	NUT, 1/4-28 Hex (see Handles & Controls page (item 58))
40	7015753	1	BALL JOINT, 1/4-28 (also shown on Handles & Controls Group page)
41	7046784	1	BELT, Engine Drive (Stretch)
42	7073528	1	DRIVE DISC, Steel
43	7013893	1	BUSHING, Powdered Metal (used for 1992 and earlier models)
43	7017696	1	BUSHING, Powdered Metal (used for 1993 and later models)

Footnotes:

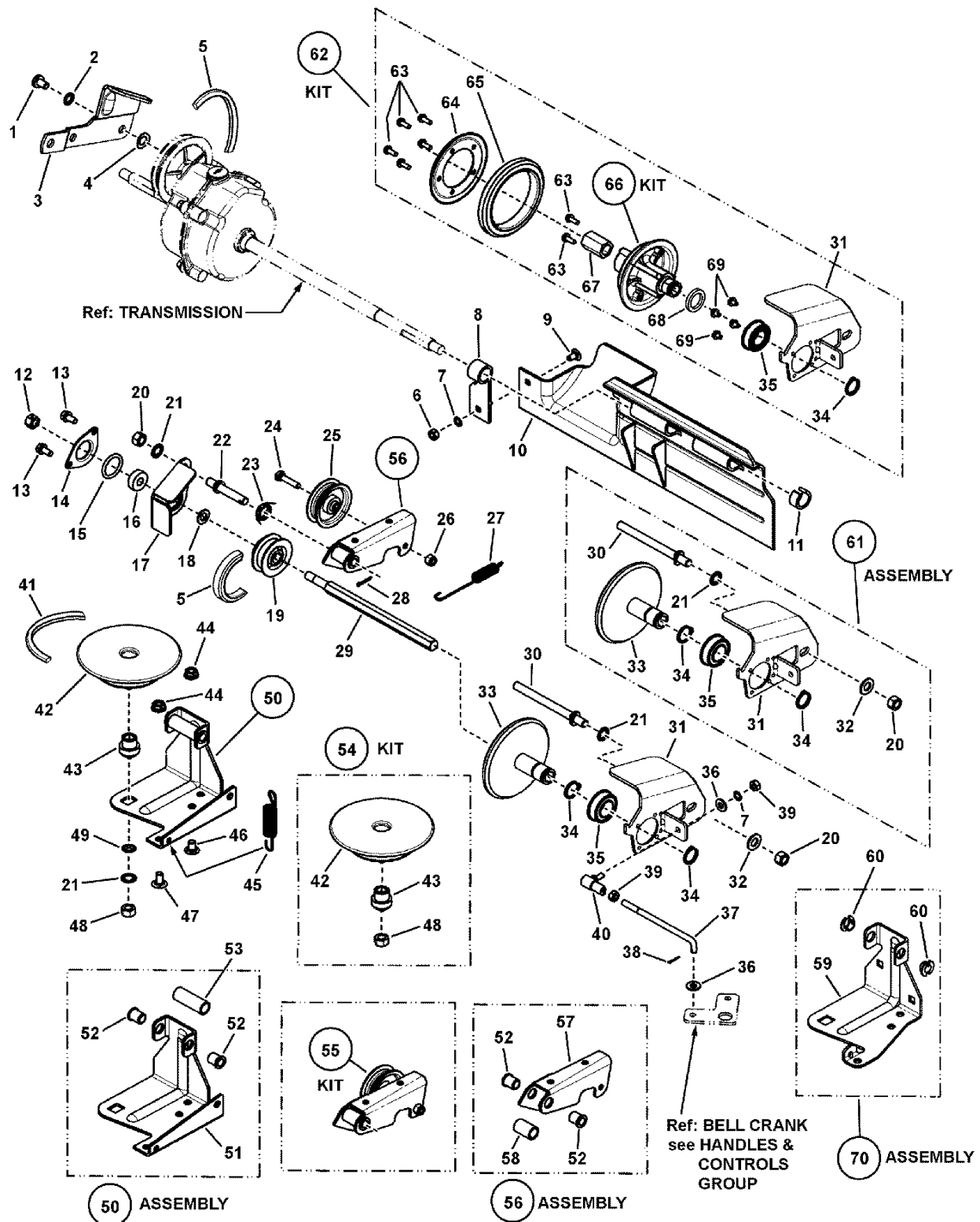

Item	Part No	Qty	Description
44	7090585	4	NUT, 5/16-18 Hex Flange Lock, GR 5 ZP (or 7091601)
45	7029025	1	SPRING, Wheel Drive
46	7090731	1	BOLT, 5/16-18 x 1/2", Short Neck Carriage, GR 5
47	7090799	1	BOLT, 5/16-18 x 5/8" Short Neck Carriage GR 5 (was 7091026)
48	7091302	1	NUT, 3/8-16 Hex
49	7013847	1	RETAINER, 3/8" Bolt
50	7052987A	1	ASSEMBLY, Deck Bracket (Incl. items 52, 53 & 59)
51	7031919	1	BRACKET, Deck - Replaced (use Items 59 & 60 or Items 51, 52 & 53)
52	7012306	2, 4	BUSHING, Flange, .381 x .625 x .62
53	7021758	1	SPACER, .500 x .65 x 1.75
54	7061275		KIT, Drive Disc Assembly (Includes Items 42, 43 & 48)
55	7051913	1	ASSEMBLY, Clutch Idler (Includes Items 24, 25, 26 & 56)
56	7500154	1	ASSEMBLY, Idler Arm (Includes Items 52, 57 & 58)
57	7032832	1	ARM, Clutch Idler
58	7100447	1	SPACER, Idler Arm
59	7033774	1	BRACKET, Deck, P21S
60	7012117	4	BUSHING, 3/8" I.D. Nylon
61	7074139	1	ASSEMBLY, Driven Disc (includes items 20, 21, & 30 thru 35)
62	7600109	1	ASS'Y, Driven Disc, Short, Commercial (Incl. same items as Kit 7061276 plus items 20, 21, 30 & 32)
--	7501000		ASS'Y, Driven Disc- Commercial (can be used instead of items 20, 21, 30, 31, 32, 33, 34, 35 & 71)
63	7090913	7	SCREW, #10-24 x 1/2" Hex Washer Self-Tap (Torx)
64	7031013	1	SIDE PLATE, Drive Tire
65	7023364	1	DRIVEN RING (was 7010927)
66	7061276	1	KIT, Hub & Bushing (Incl. Items 20, 21, 30, 31, 32, 34, 35, 63, 64, 65, 67, 68 & 69) (was 7053217)
67	7011108	1	BUSHING, Drive, Hex
68	7010121	1	WASHER, Shim, .75 x 1.0 x .021
69	7090981	4	SCREW, #10-32 x 1/4" Hex Washer Self-Tap
70	7059462	1	ASSEMBLY, Deck Bracket (Incl. items 59 & 60)
71	7501961	1	ASSEMBLY, Thrust Plate & Bearing (includes items 31 & 35)
72	7051921	1	ASSEMBLY, Clutch Idler (Includes Items 24, 25, 26, 52 & 57)

Footnotes:

Transmission (Differential)

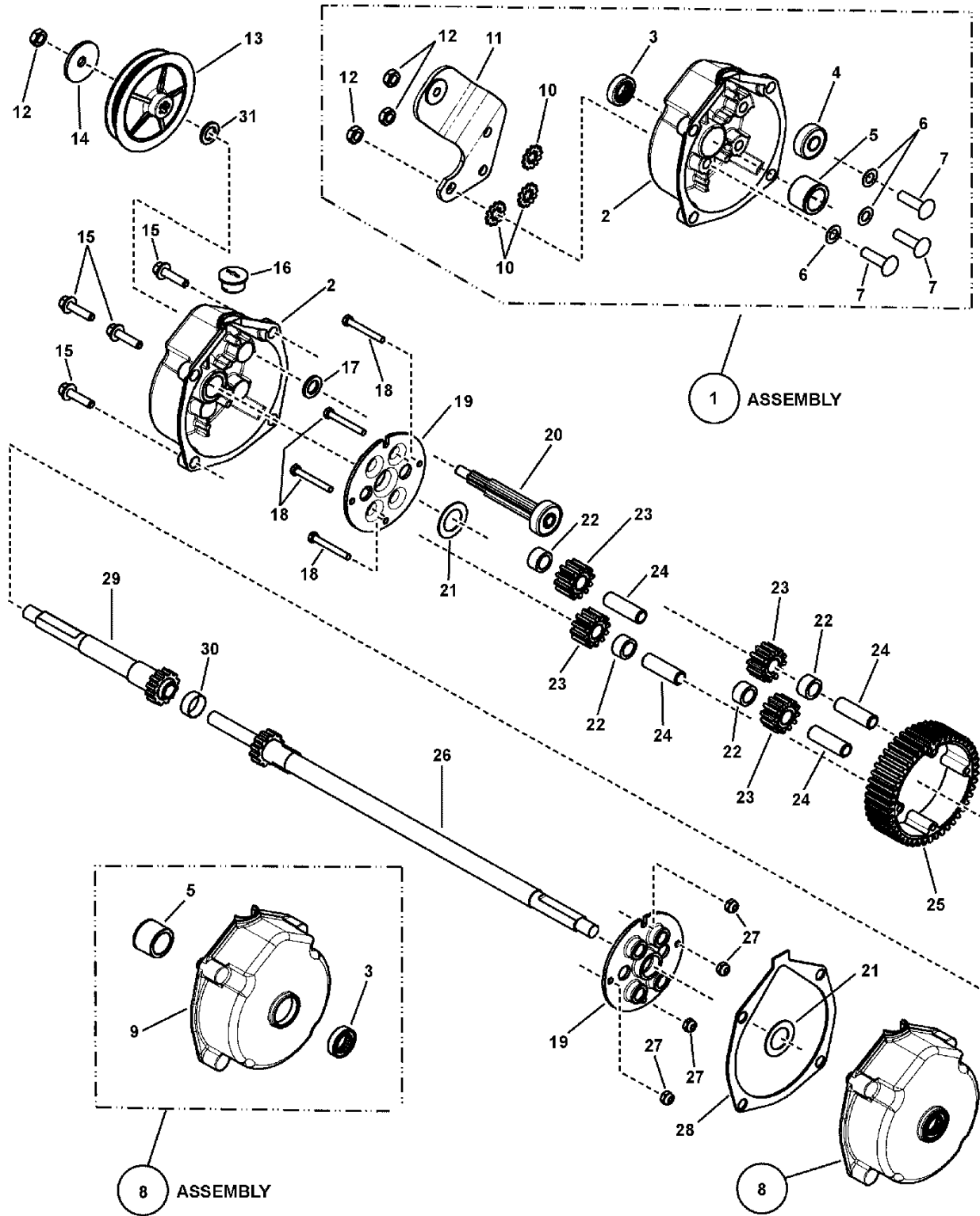

Transmission (Differential)

Item	Part No	Qty	Description
--	7053943	1	ASSEMBLY, Transmission (Incl. items 1 thru 31)
1	7053942	1	ASSEMBLY, Right Housing (Incl. items 2 thru 7) (or 7051908)
2	7029034	1	HOUSING, Right Side
3	7012314	2	SEAL, 5/8" Internal Diameter
4	7073963	1	BALL BEARING, 7/16 I.D., 1/1/8" O.D.
5	7029035	2	BEARING, Tapered (Differential Housing)
6	7024442	3	GASKET, 5/8" O. D.
7	7014155	3	SCREW, 5/16-24 x 1-1/8" Rib Neck, GR 5
8	7053939	1	ASSY, Left Housing (Incl. items 3, 5 & 9) (was 7053938)
9	7029033	1	HOUSING, Left
10	7090189	3	WASHER, 5/16" Internal/External Tooth Lock
11	7051903	1	WELDMENT, Differential Bracket
12	7092062	4	NUT, 5/16-18 Hex Lock (was 7011201)
13	7019213	1	PULLEY, Poly-V Belt (3.5" O.D.)
14	7092063	1	WASHER, Cone
15	7091825	4	SCREW, 1/4-20 x 1" Hex washer Self-Tap (was 7092064)
16	7016544	1	PLUG, Transmission Housing
17	7091720	1	WASHER, .453 x .75 x .073 Flat, YZ
18	7090557	4	SCREW, #10-32 x 1-1/2" Hex Head Cap GR 5
19	7031970	2	PLATE, 46T Gear
20	7050767	1	ASSEMBLY, Input Gear
21	7031965	2	WASHER, Thrust, 3/4" I.D.
22	7012500	4	SPACER, Pinion Gear
23	7021115	4	GEAR, Pinion (12 tooth)
24	7011110	4	SHAFT, Pinion
25	7012495	1	GEAR, Differential (46 Tooth)
26	7050831	1	ASSEMBLY, Long Axle (was 7051933)
27	7090376	4	NUT, #10-32 Hex Nyloc
28	7011774	1	GASKET, Housing
29	7050830	1	ASSEMBLY, Short Axle (was 7051932)
30	7012543	1	SPACER, Axle Gear
31	7011724	1	WASHER, 44 x .78 x .025 Curved
--	7061017	4 oz.	* "00" Grease, 32 oz bottle (not shown)

Footnotes:

NOTE: * Maximum capacity of transmission before causing leakage is 4 oz. DO NOT OVERFILL!

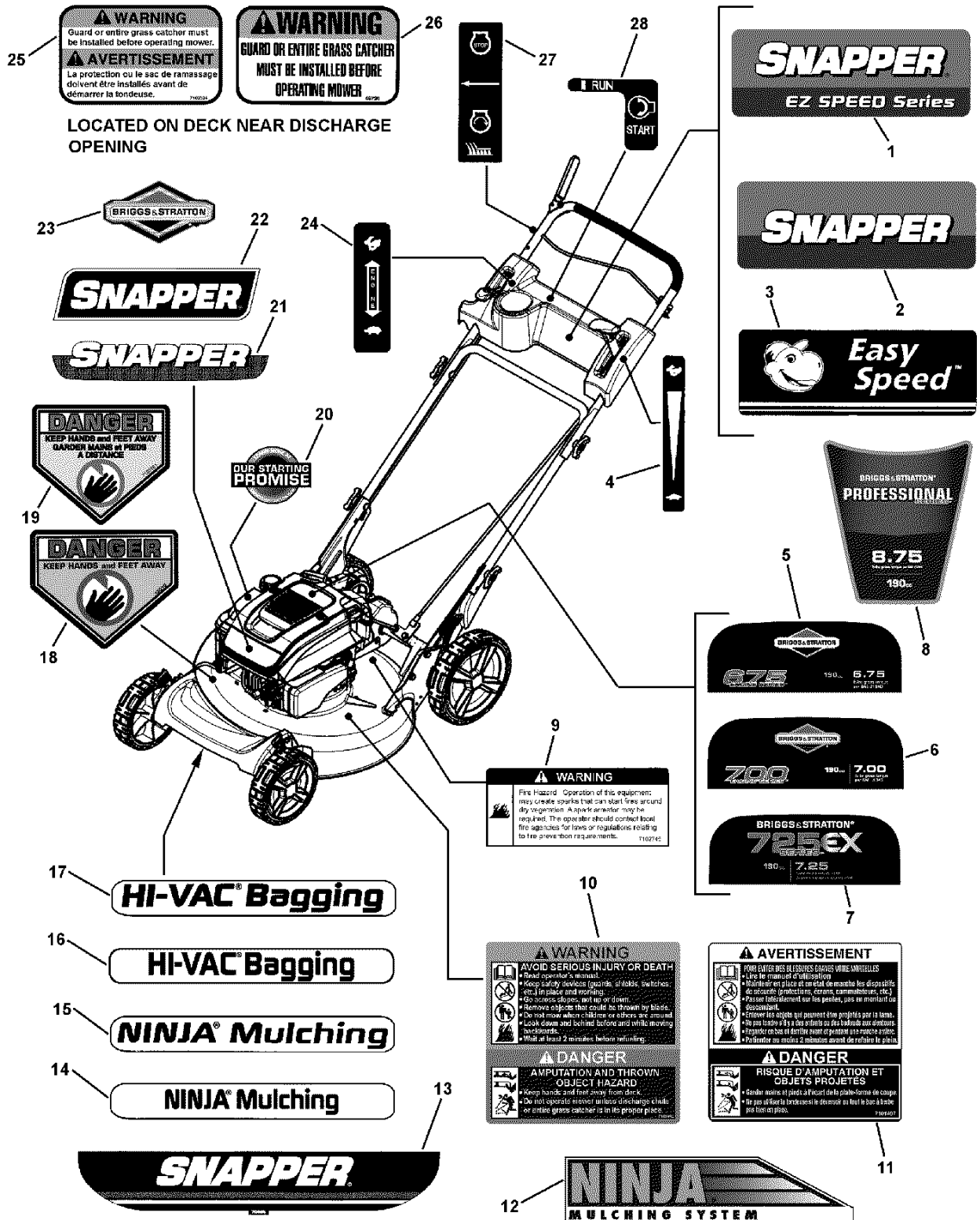

Item	Part No	Qty	Description
1	7102940	1	DECAL, Easy Speed, Control Panel
2	7102974	1	DECAL, Snapper Control Panel
3	7100183	1	DECAL, Easy Speed, Control Panel
4	7075471	1	DECAL, Speed Shift
5	7102151	1	DECAL, Briggs Engine, 675 Series
6	7103682	1	DECAL, Briggs Engine, 700 Series
7	7105198	1	DECAL, 725 Series
8	278401	1	DECAL, Briggs Engine 8.75T/190cc Professional Series
9	7102746	1	DECAL, Spart Arrestor
10	7100984	1	DECAL, Warning/Danger Walk-Behind Mowers
11	7101497	1	DECAL, Warning/Danger, French/English
12	7100410	1	DECAL, NINJA Mulching System
13	7100185	1	DECAL, SNAPPER, Steel Decks
14	7104851	1	DECAL, Ninja Mulching, Front Cover
15	7102939	1	DECAL, Front Cover, Ninja Mulching System
16	7104853	1	DECAL, Front Cover, Hi-Vac
17	7102938	1	DECAL, Front Cover, Hi-Vac
18	7013010	1	DECAL, Danger, Cut Finger
19	7105261	1	DECAL, French/English, CPSC
20	277878	1	LABEL, Starting Promise
21	7102153	1	DECAL, Briggs Engine, Snapper
22	7104148	1	DECAL, Logo, Snapper, 7.88 long
23	274040	1	LABEL, Briggs & Stratton Logo
24	7075532	1	DECAL, Throttle Control, B&S
25	7102324	1	DECAL, Chute/Deflector, French Canadian
26	7046720	1	DECAL, Chute/Deflector
27	7029782	1	DECAL, OPC Bail (International Symbol)
28	7075688	1	DECAL, Ignition Switch

Footnotes:

Side Chute, Adapter

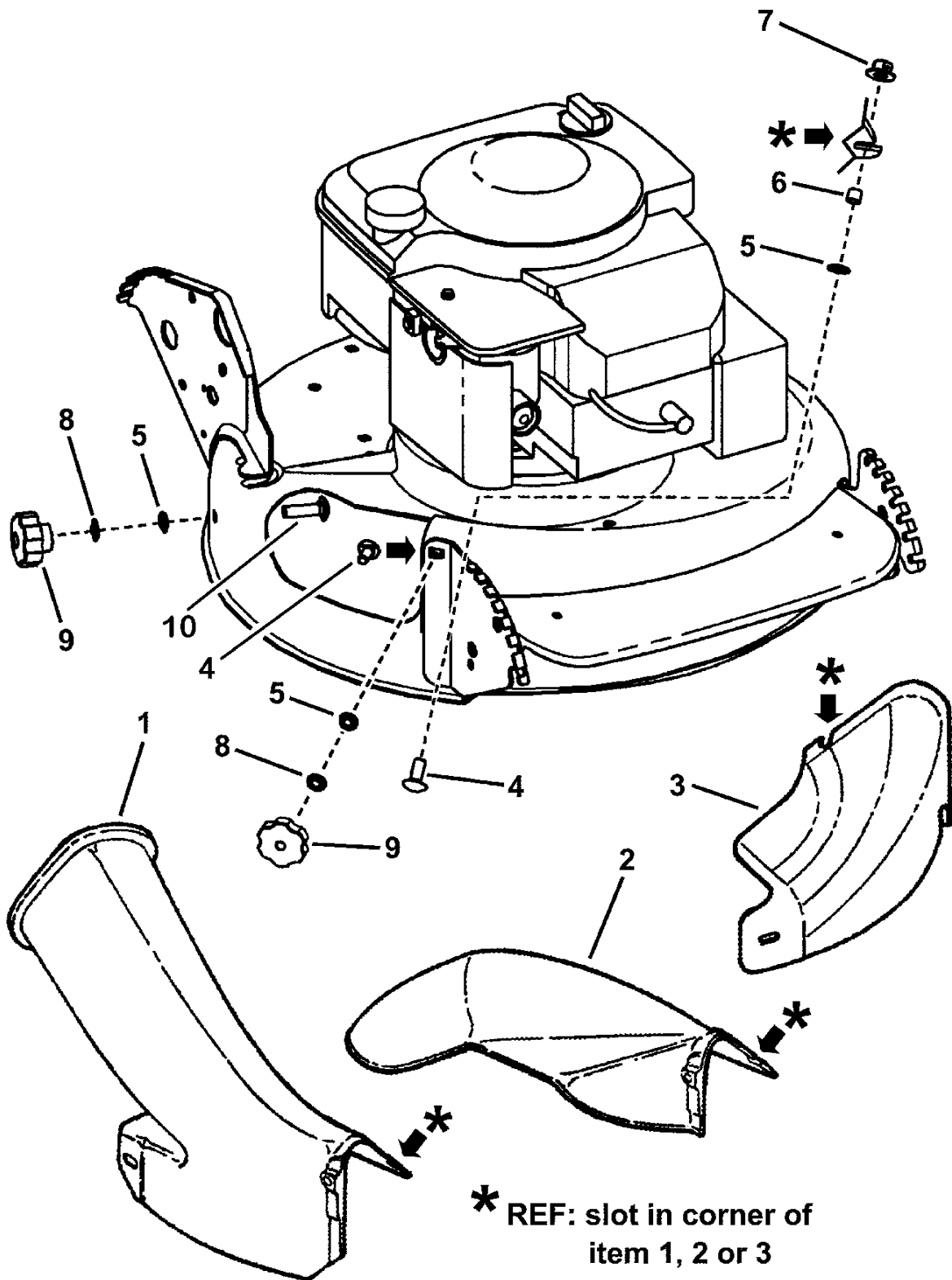

* REF: slot in corner of
item 1, 2 or 3

Item	Part No	Qty	Description
1	7047081	1	ADAPTER, Grass Bag (see Grass Bag Accessory page)
2	7042965	1	CHUTE, 21" Side
3	7029149	1	COVER, 21" Deck
4	7091169	2	BOLT, 5/16-18 x 1-1/8" Short Neck Carriage GR 5 ZP
5	7011791	1	RETAINER, 5/16" Bolt
6	7024340	1	SPACER, .316 I.D. x .375 O.D. x .310 thick
7	7090951	1	NUT, 5/16-18 Hex Large Flange Center Lock
8	7090189	2	WASHER, 5/16" Internal/External Tooth Lock
9	7101022	2	KNOB, Fluted, 5/16-18 x 1/2"
10	7091508	1	BOLT, 5/16-18 x 3/4" Short Neck Carriage GR 5 (was 7090001)

Not for
Reproduction

Footnotes:

Grass Bag Components

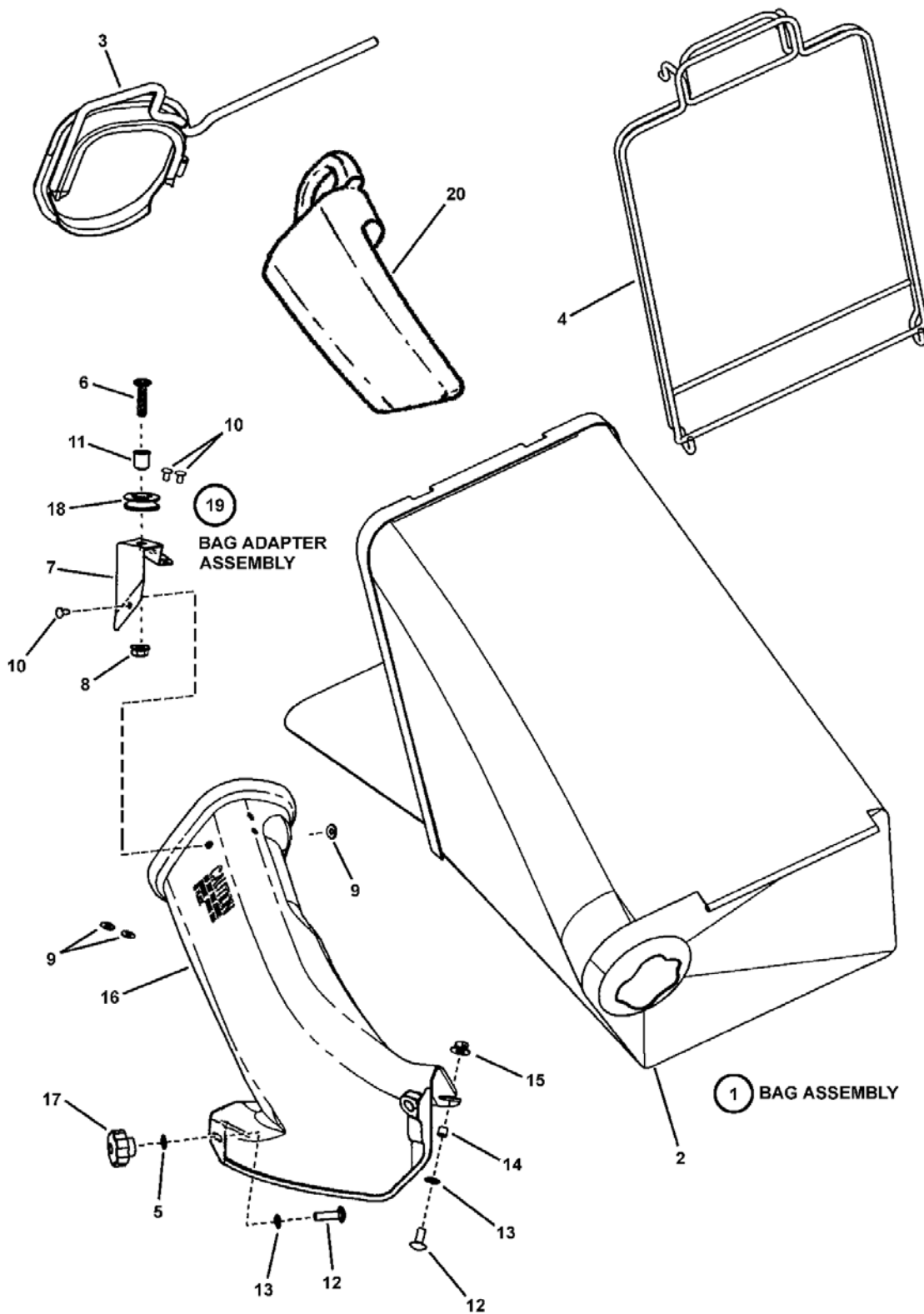

Item	Part No	Qty	Description
1	7500153	1	BAG ASSEMBLY, (Door) (includes items 2, 3 & 4)
2	7100433	1	GRASS BAG, (Door) No Graphics
3	7042489	1	CONNECTOR, Grass Bag (weldment)
4	7051906	1	ASSEMBLY, Bag Wire (12" Wide)
5	7090189	2	WASHER, 5/16" Internal/External Tooth Lock
6	7091527	1	SCREW, 5/16-18 x 1-1/4" Hex Head Cap (was 7091984)
7	7047082	1	BRACKET, Rope Guide
8	7091601	2	NUT, 5/16-18 Hex Flange Lock, GR 5 (was 7091070)
9	7072107	3	WASHER, 15/32" Flat
10	7013860	3	RIVET, 3/16 x .344
11	7012306	1	BUSHING, Flange, .381 x .625 x .62
12	7091508	3	BOLT, 5/16-18 x 3/4" Short Neck Carriage GR 5
13	7011791	3	RETAINER, 5/16" Bolt
14	7024340	1	SPACER, .316 I.D. x .375 O.D. x .310 thick
15	7090951	1	NUT, 5/16-18 Hex Large Flange Center Lock
16	7047081	1	ADAPTER, Grass Bag
17	7101022	2	KNOB, Fluted, 5/16-18 x 1/2"
18	7024228	1	PULLEY, Nylon
19	7058037	1	ASSY, Grass Bag Adapter (includes items 6, 7, 8, 9, 10, 11, 16 & 18)
20	7016814	1	PLUG, Chute Adapter

Not for
Reproduction

Footnotes:

7061200 RECYCLING COVER KIT

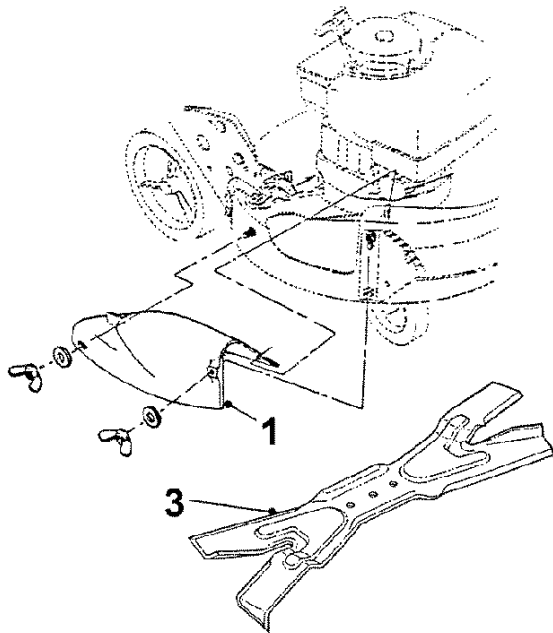

7061201 RECYCLING PLUG KIT

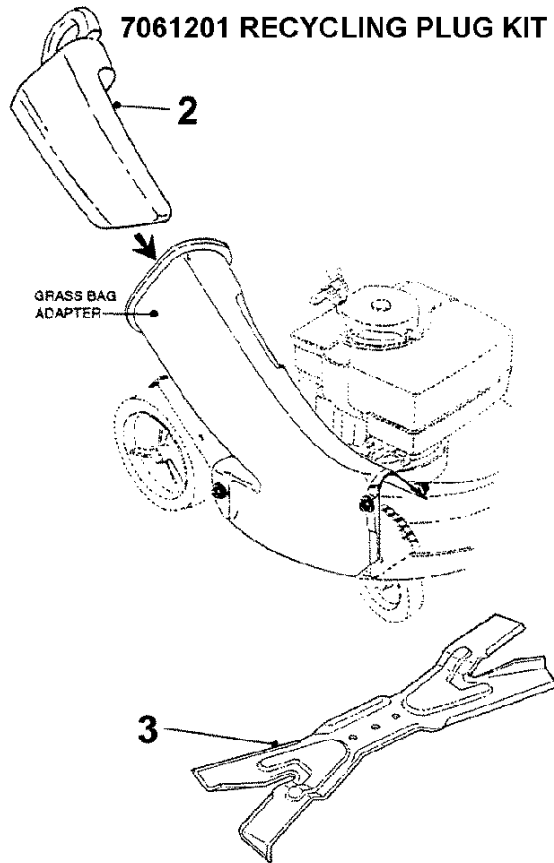

Item	Part No	Qty	Description
--	7061200		KIT, Recycling Cover (Includes items 1 & 3 shown below) (for 4HP & above engines)
--	7061201		KIT, Recycling Plug (Incl. items 2 & 3 shown below) (for 4HP & above engines)
1	7029149	1	COVER, 21" Deck
2	7016814	1	PLUG, Chute Adapter
3	7026407	1	BLADE, 21" Quad Edge Ninja

Not for
Reproduction

Footnotes:

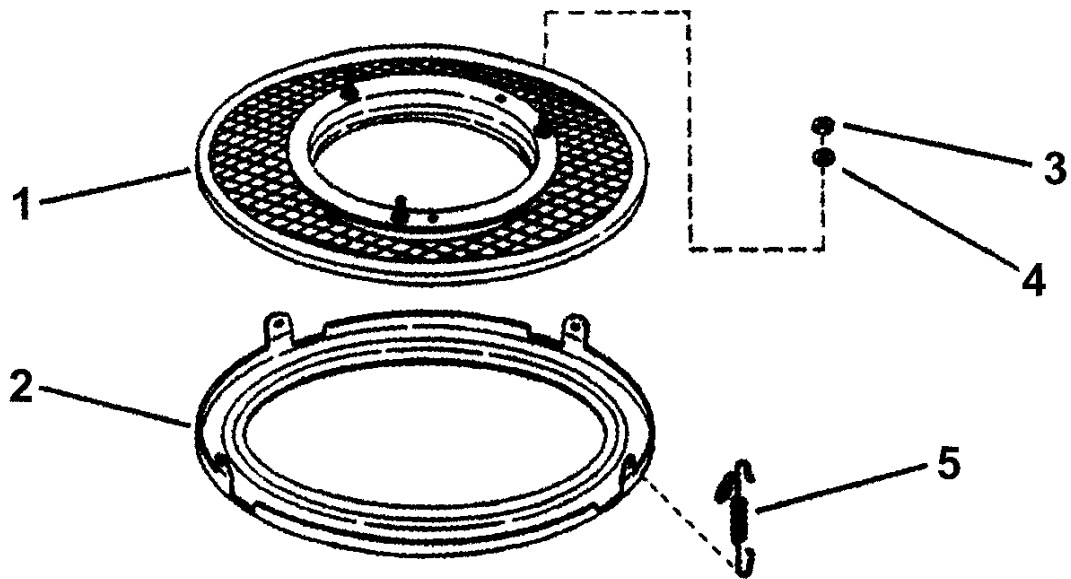

Item	Part No	Qty	Description
--	7063041		KIT, Snapperizer (Incl. items 1 thru 5) (for "FR" & "M" type outlip decks)
1	7051243	1	SCREEN, Fastener Assembly
2	7072002	1	RING, Bottom (22.60" Inside Diameter)
3	7091297	3	NUT, 5/16-24 Hex, GR 5
4	7090187	3	WASHER, 5/16" Split Lock
5	7012587	3	SPRING

Not for
Reproduction

Footnotes:

Electric Start Components

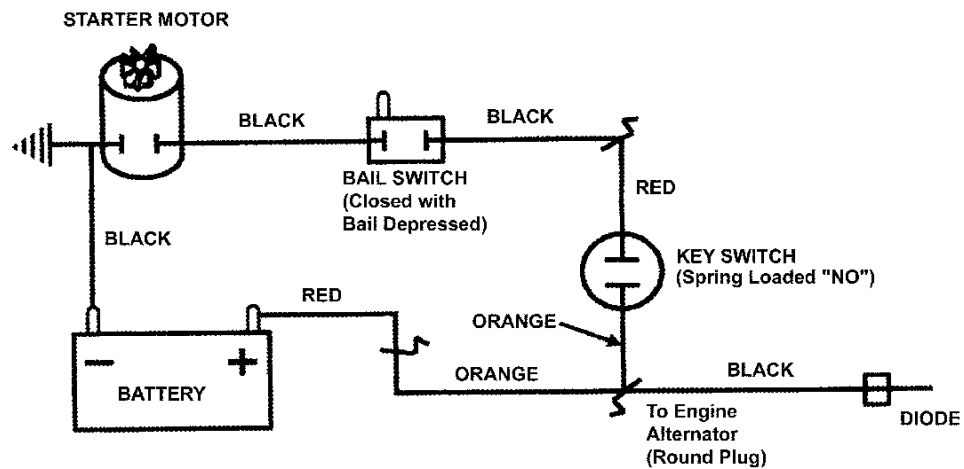
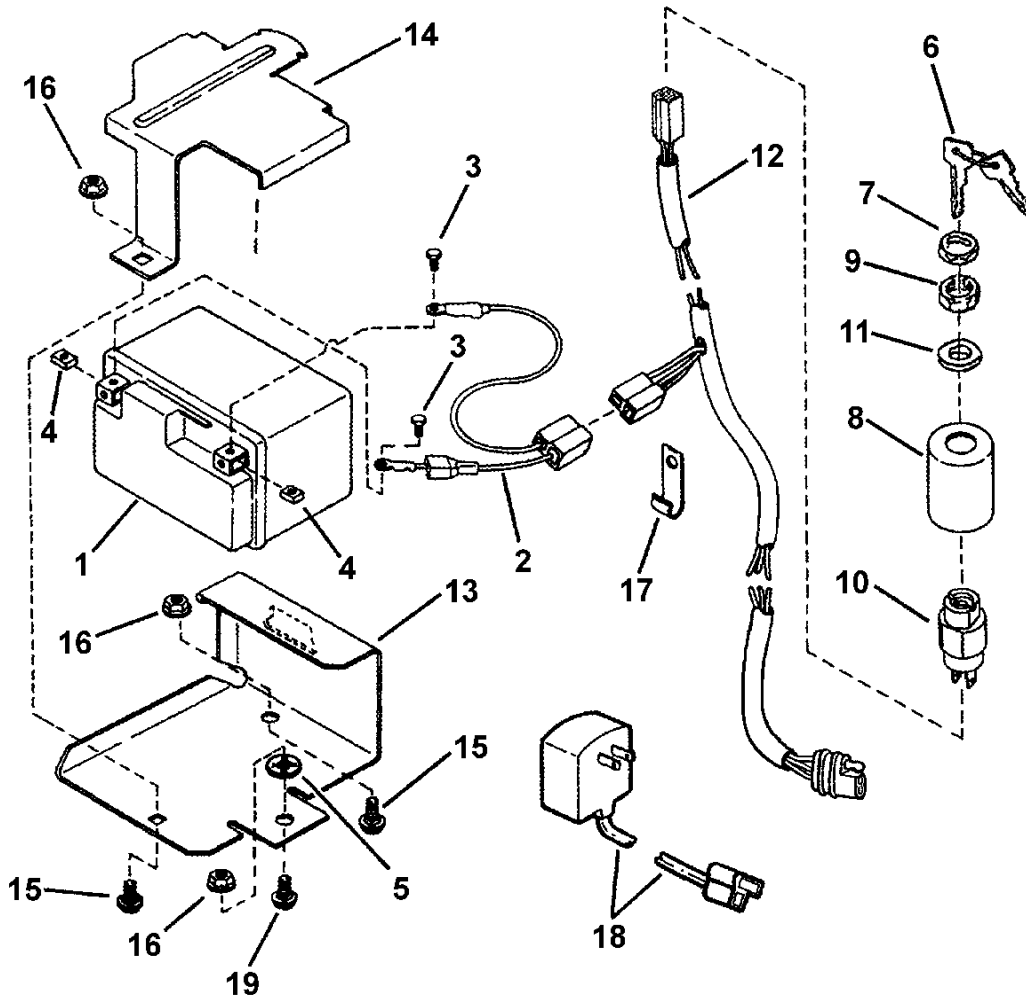

Item	Part No	Qty	Description
1	7067012	1	KIT, BATTERY, 12 Volt, 35 CCA (includes items #1 and 2)
2	7015488	1	HARNESS, Battery
3	7043977	2	SCREW, #10-24 x 1/2" Pan Head Machine
4	7090932	2	NUT, #10-24 Square
5	7011791	1	RETAINER, 5/16" Bolt
6	7011138	1	KEY, (Set of Two) (7041710, Switch Assembly, includes items 6 through 11.)
7	7023506	1	BEZEL, (Seal & Face Nut)
8	7029080	1	COVER, Switch
9	7012685	1	NUT, 5/8-32 Hex Lock
10	7028765	1	SWITCH, Ignition (spring loaded ON/OFF 2 prong)
11	7016132	1	SPACER
12	7078025	1	WIRING HARNESS, B&S WBM
13	7032906	1	BRACKET, Battery
14	7036132	1	COVER, Battery
15	7090731	2	BOLT, 5/16-18 x 1/2" Short Neck Carriage GR 5
16	7090585	3	NUT, 5/16-18 Hex Flange Lock, GR 5 YZ (or 7091601)
17	7012652	1	CLIP, Wiring
18	206838YP	1	CHARGER, Battery (120 Volt; 60 Hertz) (order Kit # 206838: Kit, Battery Charger)
19	7090799	1	BOLT, 5/16-18 x 5/8" Short Neck Carriage GR 5 (was 7091026)

Not for
Reproduction

Footnotes:

Not for
Reproduction

Hardware Identification & Torque Specifications

Torque Specification Chart FOR STANDARD METRIC MACHINE HARDWARE (Tolerance ± 20%)								
Property Class	5.6		8.8		10.9		12.9	
	Class 5.6		Class 8.8		Class 10.9		Class 12.9	
Size Of Hardware	in/lbs ft/lbs		in/lbs ft/lbs		in/lbs ft/lbs		in/lbs ft/lbs	
		Nm.		Nm.		Nm.		Nm.
M3	5.88	.56	13.44	1.28	19.2	1.80	22.92	2.15
M4	13.44	1.28	30.72	2.90	43.44	4.10	52.56	4.95
M5	26.4	2.50	60.96	5.75	5.97	8.10	7.15	9.7
M6	44.64	4.3	7.3	9.9	10.3	14	12.1	16.5
M7	5.2	7.1	12.1	16.5	16.9	23	19.9	27
M8	7.7	10.5	17.7	24	25	34	29	40
M10	15	21	35	48	50	67	59	81
M12	26	36	61	83	86.2	117	103	140
M14	42	58	101	132	136	185	162	220
M16	64	88	147	200	210	285	250	340
M18	89	121	202	275	287	390	346	470
M20	126	171	290	390	405	550	486	660
M22	169	230	390	530	559	745	656	890
M24	217	295	497	375	708	960	840	1140
M27	320	435	733	995	1032	1400	1239	1680
M30	435	590	995	1350	1401	1900	1681	2280
M33	590	800	1349	1830	1902	2580	2278	3090
M36	759	1030	1740	2360	2441	3310	2935	3980
M39	988	1340	2249	3050	3163	4290	3798	5150

Torque Specification Chart FOR STANDARD MACHINE HARDWARE (Tolerance ± 20%)						
Hardware Grade	No Marks		SAE Grade 5		SAE Grade 8	
	SAE Grade 2		SAE Grade 5		SAE Grade 8	
Size Of Hardware	in/lbs ft/lbs		in/lbs ft/lbs		in/lbs ft/lbs	
		Nm.		Nm.		Nm.
8-32	19	2.1	30	3.4	41	4.6
8-36	20	2.3	31	3.5	43	4.9
10-24	27	3.1	43	4.9	60	6.8
10-32	31	3.5	49	5.5	68	7.7
1/4-20	66	7.6	8	10.9	12	16.3
1/4-28	76	8.6	10	13.6	14	19.0
5/16-18	11	15.0	17	23.1	25	34.0
5/16-24	12	16.3	19	25.8	29	34.0
3/8-16	20	27.2	30	40.8	45	61.2
3/8-24	23	31.3	35	47.6	50	68.0
7/16-14	30	40.8	50	68.0	70	95.2
7/16-20	35	47.6	55	74.8	80	108.8
1/2-13	50	68.0	75	102.0	110	149.6
1/2-20	55	74.8	90	122.4	120	163.2
9/16-12	65	88.4	110	149.6	150	204.0
9/16-18	75	102.0	120	163.2	170	231.2
5/8-11	90	122.4	150	204.0	220	299.2
5/8-18	100	136	180	244.8	240	326.4
3/4-10	160	217.6	260	353.6	386	525.0
3/4-16	180	244.8	300	408.0	420	571.2
7/8-9	140	190.4	400	544.0	600	816.0
7/8-14	155	210.8	440	598.4	660	897.6
1-8	220	299.2	580	788.8	900	1,244.0
1-12	240	326.4	640	870.4	1,000	1,360.0

The guides and ruler furnished below are designed to help you select the appropriate hardware.



Nut, M8

Thread Diameter (mm)
Inside Diameter (in)
Threads per inch

Nut, 1/2-16

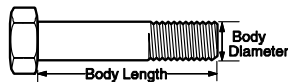

Screw, M8- 1.25 x 25

Thread Diameter (mm)
Body Diameter
Distance between threads (mm)
Threads per inch
Body Length (mm)
Body Length (in)

Screw, 1/2- 16 x 2

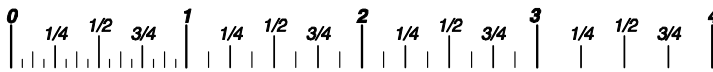

Standard Hardware Sizing

When a washer or nut is identified as 1/2" (M8), this is the *Nominal size*, meaning the *inside diameter* is 1/2 inch (8mm metric thread diameter); if a second number is present it represents the *threads per inch* (distance between threads).

When bolt or capscrew is identified as 1/2 - 16 x 2" (M8 - 1.25 x 50), this means the *Nominal size*, or body diameter is 1/2 inch (8mm metric thread diameter), the second number, 16, represents the *threads per inch*, (1.25 thread diameter). The final number is the body length of the bolt or screw, 2 inches (50mm).

NOTES

- These torque values are to be used for all hardware excluding: locknuts, self-tapping screws, thread forming screws, sheet metal screws and socket head setscrews.
- Recommended seating torque values for locknuts:
 - for prevailing torque locknuts - use 65% of grade5 torques.
 - for flange whizlock nuts and screws - use 135% of grade 5 torques.
- Unless otherwise noted on assembly drawings, all torque values must meet this specification.

Common Hardware Types

Hex Head Capscrew



Washer

Lockwasher

Carriage Bolt

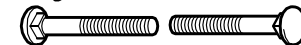

Hex Nut

Wrench & Fastener Size Guide

1/4" Bolt or Nut Wrench—7/16"	5/16" Bolt or Nut Wrench—1/2"	3/8" Bolt or Nut Wrench—9/16"	7/16" Bolt or Nut Wrench (Bolt)—5/8" Wrench (Nut)—11/16"	1/2" Bolt or Nut Wrench—3/4"
M6 Bolt or Nut Wrench—10mm	M8 Bolt or Nut Wrench—13mm	M10 Bolt or Nut Wrench—17mm	M12 Bolt or Nut Wrench—19mm	M14 Bolt or Nut Wrench—22mm

Parts Manual for

SNAPPER®

21" STEEL DECK WALK BEHIND MOWERS SERIES 20

Not for
Reproduction

IT IS THE POLICY OF BRIGGS & STRATTON CORP. TO IMPROVE ITS PRODUCTS WHENEVER IT IS POSSIBLE AND PRACTICAL TO DO SO. WE RESERVE THE RIGHT TO MAKE CHANGES OR ADD IMPROVEMENTS AT ANY TIME WITHOUT INCURRING ANY OBLIGATION TO MAKE SUCH CHANGES ON PRODUCTS MANUFACTURED

Briggs & Stratton Yard Power Products Group

535 Macon Road
McDonough, GA, 30253 U.S.A.
800-935-2967

www.snapper.com

Copyright © 2011 Briggs & Stratton Corporation
Milwaukee, WI USA. All Rights Reserved

**Manual No. 7006477
Revision: G 10/28/2011**