

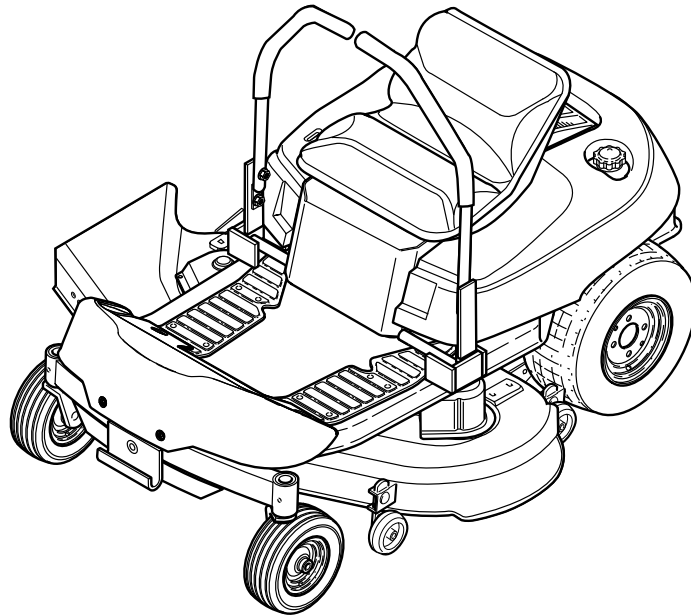

OPERATOR'S MANUAL



Axion / 150Z ZTR Series

20HP Zero-Turn Riders

Mfg. No.	Description
2690715	Simplicity Axion, 20HP w/ 42" Mower (CE)
2690716	Snapper 150Z, 20HP w/ 42" Mower (CE)
2690770	Simplicity Axion, 20HP w/42" Mower (AUST)

1734212
Revision 03
Rev. Date 10/2007
TP 100-4470-03-ZT-SN

TABLE OF CONTENTS

Safety Rules

General Operation.....	2
Transportation & Storage	2
Slope Operation	3
Towed Equipment.....	3
Children.....	3
Emissions.....	3
Ignition System	3
Slope Sighting Guide	4
Service & Maintenance	5

Safety & Operation Decals.....6

Identification Numbers.....8

Operation

Control Functions	9
General Operating Safety	10
Checks before Starting.....	11
Fuel Recommendations	11
Emergency Stopping.....	12
Stopping the Rider and Engine	12
Starting the Engine	12
Mowing.....	12
Pushing the Rider by Hand	12
Driving Practice	13
Mower Deck Removal & Installation.....	15

Maintenance

Maintenance Schedule	14
Rider Maintenance	
Accessing the Engine Compartment.....	17
Clean Debris from Rider and Engine	17
Clean Debris from Engine Cooling Areas	17
Check Tire Pressure.....	17
Lubrication	18
Clean Deck & Check/Replace Mower Blades	19
Clean the Battery & Cables.....	20
Check Rider Safety System	20
Check/Adjust PTO Clutch.....	21
Engine Maintenance	
Check Engine Oil Level	22
Change Engine Oil	22
Change Engine Oil & Filter	22
Service Air Filter & Pre-Cleaner.....	23
Replace Spark Plug	24

Service & Adjustments

Ground Speed Control Lever Adjustment	25
Speed Balancing Adjustment.....	25
Cutting Height Adjustment	25
PTO Clutch Adjustment.....	25
Brake Adjustment.....	26
Battery Charging	26
Engine Adjustments	26
Mower Deck Leveling Adjustments	27
Mower Belt Replacement	28
Storage.....	29

Troubleshooting

Troubleshooting the Rider - Chart	30
Troubleshooting the Mower - Chart	31

Specifications

Service Items

Notes.....

Lawn Care

NOTE: In this manual, “left” and “right” are referred to as seen from the operating position.

SAFETY RULES



Read these safety rules and follow them closely. Failure to obey these rules could result in loss of control of unit, severe personal injury or death to you, or bystanders, or damage to property or equipment.

This mowing deck is capable of amputating hands and feet and throwing objects.

The triangle  in text signifies important cautions or warnings which must be followed.

GENERAL OPERATION

1. Read, understand, and follow all instructions in the manual and on the unit before starting.
2. Do not put hands or feet near rotating parts or under the machine. Keep clear of the discharge opening at all times.
3. Only allow responsible adults, who are familiar with the instructions, to operate the unit (local regulations can restrict operator age).
4. Clear the area of objects such as rocks, toys, wire, etc., which could be picked up and thrown by the blade(s).
5. Be sure the area is clear of other people before mowing. Stop the unit if anyone enters the area.
6. Never carry passengers.
7. Do not mow in reverse unless absolutely necessary. Always look down and behind before and while travelling in reverse.
8. Never direct discharge material toward anyone. Avoid discharging material against a wall or obstruction. Material may ricochet back toward the operator. Stop the blade(s) when crossing gravel surfaces.
9. Do not operate the machine without the entire grass catcher, discharge guard (deflector), or other safety devices in place and operational.
10. Slow down before turning.
11. Never leave a running unit unattended. Always disengage the blades (PTO), set parking brake, stop engine, and remove keys before dismounting.
12. Disengage blades (PTO) when not mowing. Shut off engine and wait for all parts to come to a complete stop before cleaning the machine, removing the grass catcher, or unlogging the discharge guard.
13. Operate the machine only in daylight or good artificial light.
14. Do not operate the unit while under the influence of alcohol or drugs.
15. Watch for traffic when operating near or crossing roadways.
16. Use extra care when loading or unloading the unit into a trailer or truck.
17. Always wear eye protection when operating this unit.
18. Data indicates that operators, age 60 years and above, are involved in a large percentage of power equipment-related injuries. These operators should evaluate their ability to operate the equipment safely enough to protect themselves and others from injury.
19. Follow the manufacturer's recommendations for wheel weights or counterweights.
20. Keep in mind the operator is responsible for accidents occurring to other people or property.
21. All drivers should seek and obtain professional and practical instruction.
22. Always wear substantial footwear and trousers. Never operate when barefoot or wearing sandals.
23. Before using, always visually check that the blades and blade hardware are present, intact, and secure. Replace worn or damaged parts.
24. Disengage attachments before: refueling, removing an attachment, making adjustments (unless the adjustment can be made from the operator's position).
25. When the machine is parked, stored, or left unattended, lower the cutting means unless a positive mechanical lock is used.
26. Before leaving the operator's position for any reason, engage the parking brake, disengage the blades (PTO), stop the engine, and remove the key.
27. To reduce fire hazard, keep the unit free of grass, leaves, & excess oil. Do not stop or park over dry leaves, grass, or combustible materials.
28. It is a violation of California Public Resource Code Section 4442 to use or operate the engine on or near any forest-covered, brush-covered, or grass-covered land unless the exhaust system is equipped with a spark arrester meeting any applicable local or state laws. Other states or federal areas may have similar laws.
29. OSHA regulations may require the use of hearing protection when exposed to sound levels greater than 85 dBA for an 8 hour time period.

CAUTION



This machine produces sound levels in excess of 85 dBA at the operator's ear and can cause hearing loss through extended periods of exposure.

Wear hearing protection when operating this machine.

TRANSPORTING AND STORAGE

1. When transporting the unit on an open trailer, make sure it is facing forward, in the direction of travel. If the unit is facing backwards, wind lift could damage the unit.
2. Always observe safe refueling and fuel handling practices when refueling the unit after transportation or storage.
3. Never store the unit (with fuel) in an enclosed poorly ventilated structure. Fuel vapors can travel to an ignition source (such as a furnace, water heater, etc.) and cause an explosion. Fuel vapor is also toxic to humans and animals.
4. Never store the unit or fuel container inside where there is an open flame or pilot light, such as near a water heater. Allow unit to cool before storing.

SLOPE OPERATION

Slopes are a major factor related to loss-of-control and tip-over accidents, which can result in severe injury or death. Operation on all slopes requires extra caution. If you cannot back up the slope or if you feel uneasy on it, do not operate on it.

Control of a walk-behind or ride-on machine sliding on a slope will not be regained by the application of the brake. The main reasons for loss of control are: insufficient tire grip on the ground, speed too fast, inadequate braking, the type of machine is unsuitable for its task, lack of awareness of the ground conditions, incorrect hitching and load distribution.

1. Mow up and down the face of slopes, not across.
2. Watch for holes, ruts, or bumps. Uneven terrain could overturn the unit. Tall grass can hide obstacles.
3. Choose a slow speed so that you will not have to stop or change speeds while on the slope.
4. Do not mow on wet grass. Tires may lose traction.
5. Avoid starting, stopping, or turning on a slope. If tires lose traction (i.e. machine stops forward motion on a slope), disengage the blade(s) (PTO) and drive slowly off the slope.
6. Keep all movement on slopes slow and gradual. Do not make sudden changes in speed or direction, which could cause the machine to rollover.
7. Use extra care while operating machines with grass catchers or other attachments; they can affect the stability of the unit. Do not use on steep slopes.
8. Do not try to stabilize the machine by putting your foot on the ground (ride-on units).
9. Do not mow near drop-offs, ditches, or embankments. The mower could suddenly turn over if a wheel is over the edge of a cliff or ditch, or if an edge caves in.
10. Do not use grass catchers on steep slopes.
11. Do not mow slopes if you cannot back up them.
12. See your authorized dealer/retailer for recommendations of wheel weights or counterweights to improve stability.
13. Remove obstacles such as rocks, tree limbs, etc.
14. Use slow speed. Tires may lose traction on slopes even through the brakes are functioning properly.
15. Do not turn on slopes unless necessary, and then, turn slowly and gradually uphill, if possible. Never mow down slopes.

TOWED EQUIPMENT (RIDE-ON UNITS)

1. Tow only with a machine that has a hitch designed for towing. Do not attach towed equipment except at the hitch point.
2. Follow the manufacturer's recommendations for weight limit for towed equipment and towing on slopes. See attaching a trailer under OPERATION.
3. Never allow children or others in or on towed equipment.
4. On slopes, the weight of the towed equipment may cause loss of traction and loss of control.
5. Travel slowly and allow extra distance to stop.
6. Do not shift to neutral and coast down hill.

WARNING

Never operate on slopes greater than 17.6 percent (10°) which is a rise of 3-1/2 feet (106 cm) vertically in 20 feet (607 cm) horizontally.

Select slow ground speed before driving onto slope. Use extra caution when operating on slopes with rear-mounted grass catchers.

Mow up and down the face of slopes, not across. Use caution when changing directions and **DO NOT START OR STOP ON SLOPE.**

CHILDREN

Tragic accidents can occur if the operator is not alert to the presence of children. Children are often attracted to the unit and the mowing activity. Never assume that children will remain where you last saw them.

1. Keep children out of the mowing area and under the watchful care of another responsible adult.
2. Be alert and turn unit off if children enter the area.
3. Before and during reverse operation, look behind and down for small children.
4. Never carry children, even with the blade(s) off. They may fall off and be seriously injured or interfere with safe unit operation. Children who have been given rides in the past may suddenly appear in the mowing area for another ride and be run over or backed over by the machine.
5. Never allow children to operate the unit.
6. Use extra care when approaching blind corners, shrubs, trees, or other objects that may obscure vision.

EMISSIONS

1. Engine exhaust from this product contains chemicals known, in certain quantities, to cause cancer, birth defects, or other reproductive harm.
2. Look for the relevant Emissions Durability Period and Air Index information on the engine emissions label.

IGNITION SYSTEM

1. This spark ignition system complies with Canadian ICES-002.

SUGGESTED GUIDE FOR SIGHTING SLOPES FOR SAFE OPERATION OF RIDER WITH ATTACHMENT

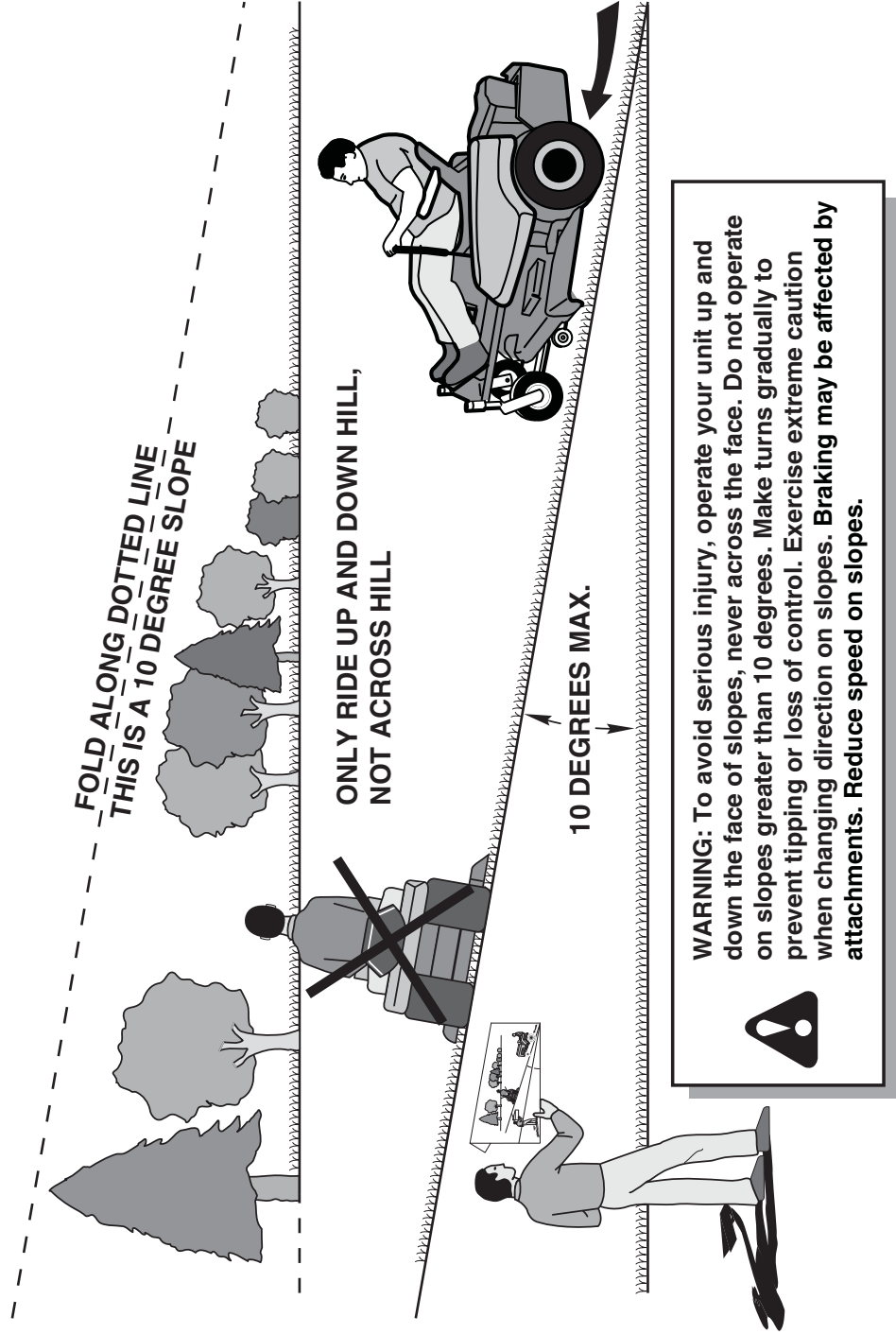

1. Fold this page along dotted line indicated above.
2. Hold page before you so that its left edge is vertically parallel to a tree trunk or other upright structure.
3. Sight across the fold in the direction of hill slope you want to measure.
4. Compare the angle of the fold with the slope of the hill.

SERVICE AND MAINTENANCE

Safe Handling of Gasoline

1. Extinguish all cigarettes, cigars, pipes, and other sources of ignition.
2. Use only approved gasoline containers.
3. Never remove the gas cap or add fuel with the engine running. Allow the engine to cool before refueling.
4. Never fuel the machine indoors.
5. Never store the machine or fuel container where there is an open flame, spark, or pilot light such as near a water heater or other appliance.
6. Never fill containers inside a vehicle or on a truck bed with a plastic bed liner. Always place containers on the ground away from your vehicle before filling.
7. Remove gas-powered equipment from the truck or trailer and refuel it on the ground. If this is not possible, then refuel such equipment on a trailer with a portable container, rather than from a gasoline dispenser nozzle.
8. Keep nozzle in contact with the rim of the fuel tank or container opening at all times until fueling is complete. Do not use a nozzle lock-open device.
9. If fuel is spilled on clothing, change clothing immediately.
10. Never over-fill the fuel tank. Replace gas cap and tighten securely.
11. Use extra care in handling gasoline and other fuels. They are flammable and vapors are explosive.
12. If fuel is spilled, do not attempt to start the engine but move the machine away from the area of spillage and avoid creating any source of ignition until fuel vapors have dissipated.
13. Replace all fuel tank caps and fuel container caps securely.

Service & Maintenance

1. Never run the unit in an enclosed area where carbon monoxide fumes may collect.
2. Keep nuts and bolts, especially blade attachment bolts, tight and keep equipment in good condition.
3. Never tamper with safety devices. Check their proper operation regularly and make necessary repairs if they are not functioning properly.
4. Keep unit free of grass, leaves, or other debris build-up. Clean up oil or fuel spillage, and remove any fuel-soaked debris. Allow machine to cool before storage.
5. If you strike an object, stop and inspect the machine. Repair, if necessary, before restarting.
6. Never make adjustments or repairs with the engine running.
7. Check grass catcher components and the discharge guard frequently and replace with manufacturer's recommended parts, when necessary.
8. Mower blades are sharp. Wrap the blade or wear gloves, and use extra caution when servicing them.
9. Check brake operation frequently. Adjust and service as required.
10. Maintain or replace safety and instructions labels, as necessary.
11. Do not remove the fuel filter when the engine is hot as spilled gasoline may ignite. Do not spread fuel line clamps further than necessary. Ensure clamps grip hoses firmly over the filter after installation.
12. Do not use gasoline containing METHANOL, gasohol containing more than 10% ETHANOL, gasoline additives, or white gas because engine/fuel system damage could result.
13. If the fuel tank must be drained, it should be drained outdoors.
14. Replace faulty silencers/mufflers.
15. Maintain or replace safety and instruction labels as necessary.
16. Use only authorized replacement parts when making repairs.
17. Always comply with factory specifications on all settings and adjustments.
18. Only authorized service locations should be utilized for major service and repair requirements.
19. Never attempt to make major repairs on this unit unless you have been properly trained. Improper service procedures can result in hazardous operation, equipment damage and voiding of manufacturer's warranty.
20. On multiple blade mowers, take care as rotating one blade can cause other blades to rotate.
21. Do not change engine governor settings or over-speed the engine. Operating the engine at excessive speed can increase the hazard of personal injury.
22. Disengage drive attachments, stop the engine, remove the key, and disconnect the spark plug wire(s) before: clearing attachment blockages and chutes, performing service work, striking an object, or if the unit vibrates abnormally. After striking an object, inspect the machine for damage and make repairs before restarting and operating the equipment.
23. Never place hands near the moving parts, such as a hydro pump cooling fan, when the tractor is running. (Hydro pump cooling fans are typically located on top of the transaxle).
24. Units with hydraulic pumps, hoses, or motors:
WARNING: Hydraulic fluid escaping under pressure may have sufficient force to penetrate skin and cause serious injury. If foreign fluid is injected into the skin it must be surgically removed within a few hours by a doctor familiar with this form of injury or gangrene may result. Keep body and hands away from pin holes or nozzles that eject hydraulic fluid under high pressure. Use paper or cardboard, and not hands, to search for leaks. Make sure all hydraulic fluid connections are tight and all hydraulic hoses and lines are in good condition before applying pressure to the system. If leaks occur, have the unit serviced immediately by your authorized service center.
25. **WARNING:** Stored energy device. Improper release of springs can result in serious personal injury. Springs should be removed by an authorized technician.

SAFETY & OPERATION DECALS

This unit has been designed and manufactured to provide you with the safety and reliability you would expect from an industry leader in outdoor power equipment manufacturing.

Although reading this manual and the safety instructions it contains will provide you with the necessary basic knowledge to operate this equipment safely and effectively, we have placed several safety labels on the unit to remind you of this important information while you are operating your unit.

All DANGER, WARNING, CAUTION and instructional messages on your rider and mower should be carefully

read and obeyed. Personal bodily injury can result when these instructions are not followed. The information is for your safety and it is important! The safety decals below are on your rider and mower.

If any of these decals are lost or damaged, replace them at once. Contact your dealer for replacements.

These labels are easily applied and will act as a constant visual reminder to you, and others who may use the equipment, to follow the safety instructions necessary for safe, effective operation.

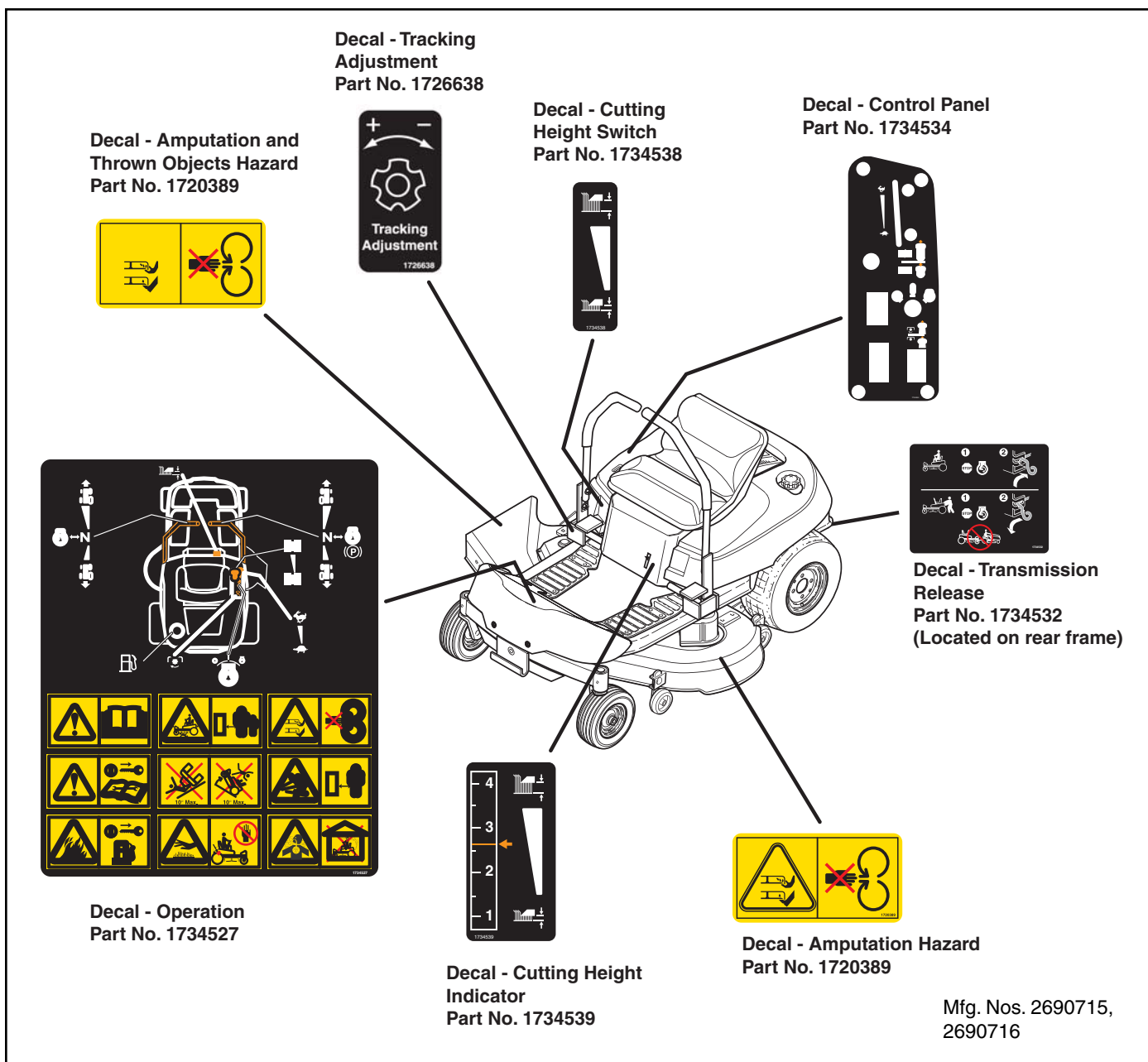

Decal - Amputation and Thrown Objects Hazard
Part No. 1704277



Decal - Operation, Upper
Part No. 1734236

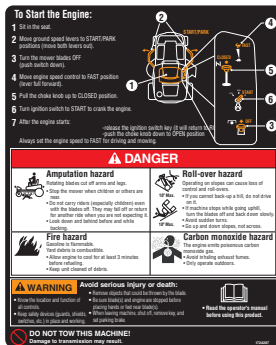
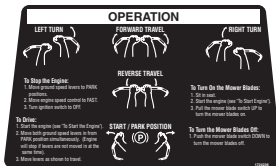

Decal - Operation, Lower
Part No. 1734207

Decal - Tracking Adjustment
Part No. 1726638



Decal - Ground Speed Lever
Part No. 1734271

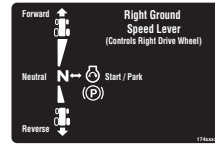

Decal - Cutting Height Switch
Part No. 1734276



Decal - Control Panel
Part No. 1734272

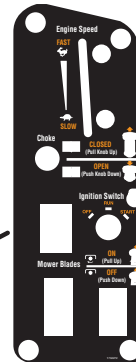

Decal - Cutting Hazard
Part No. 1734672
(Located on rear frame)



Decal - Transmission Release
Part No. 1734532
(Located on rear frame)

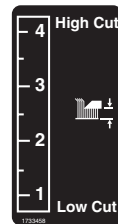

Decal - Cutting Height Indicator
Part No. 1733458



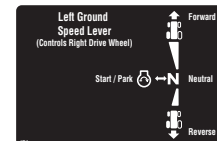

Decal - Amputation Hazard
Part No. 1704276



Decal - Ground Speed Lever
Part No. 1734270

Mfg. No. 2690770

IDENTIFICATION NUMBERS

Simplicity Manufacturing, Inc. Port Washington, WI 53074-0997 USA	
MODEL XX XX XX X/XXX-XXXX XX XXX 	
PART NO. 20 XXXX 	
SERIAL NO. XXXXXXXXXX 	

When contacting the service center for replacement parts, service, or information you **MUST** have these numbers.

Record your model name/number, manufacturer's identification numbers, and engine serial numbers in the space provided for easy access.

The identification tag is located on the underside of the seat. Tilt the seat forward to access the ID tag.

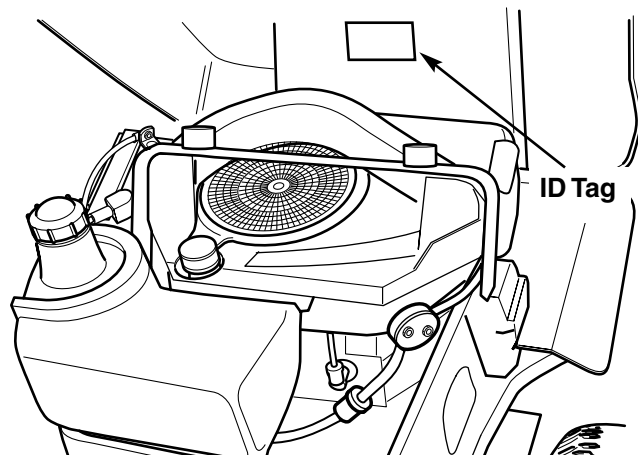

PRODUCT REFERENCE DATA	
Model Description Name/Number	
Part Number	Unit Serial Number
Date Purchased	
ENGINE REFERENCE DATA	
Engine Make	Engine Model
Engine Type/Spec	Engine Code/Serial Number

OPERATION

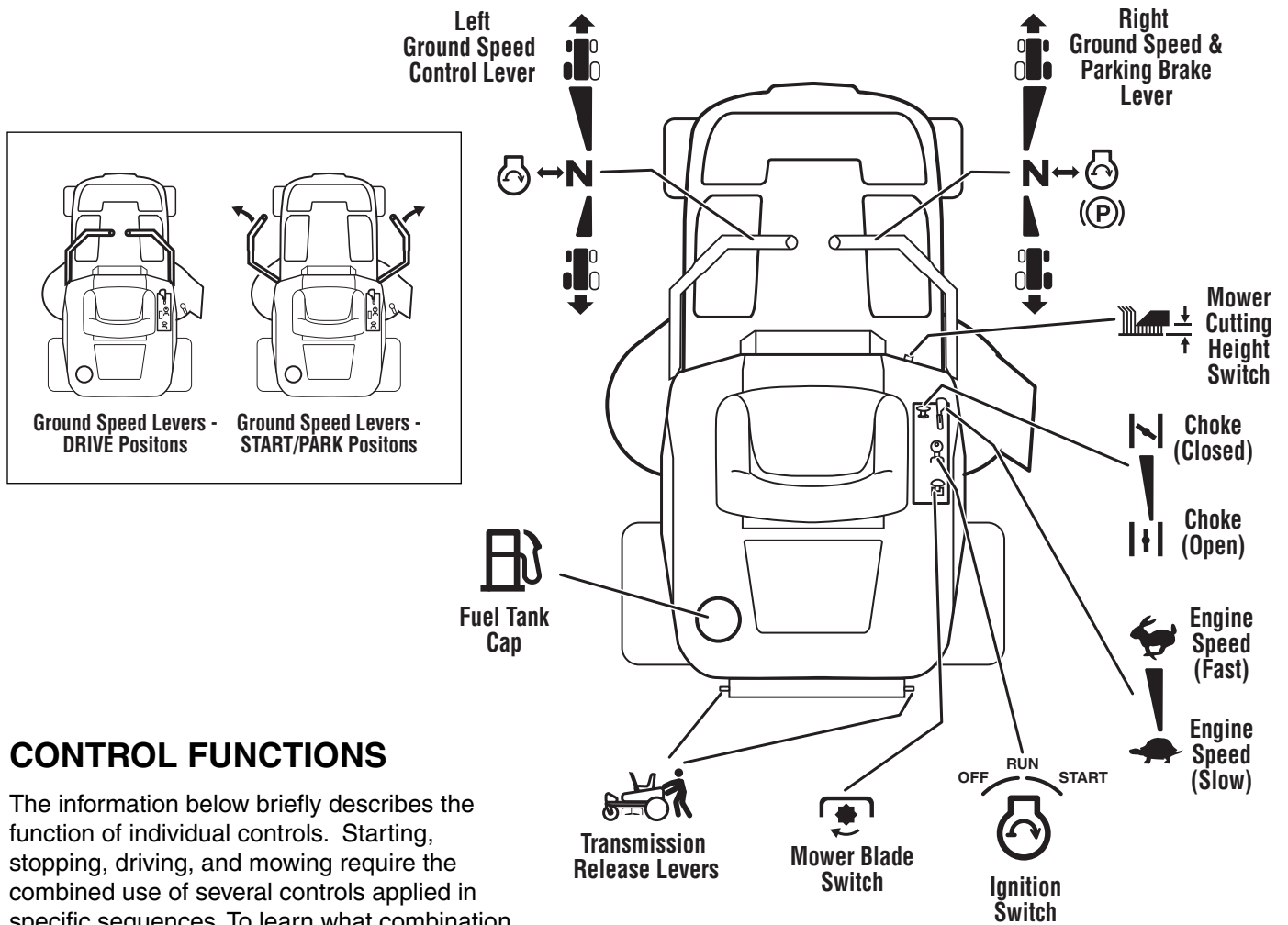

Figure 1. Controls

CONTROL FUNCTIONS

The information below briefly describes the function of individual controls. Starting, stopping, driving, and mowing require the combined use of several controls applied in specific sequences. To learn what combination and sequence of controls to use for various tasks please read the entire section.

Ground Speed Levers / Parking Brake

These levers control the ground speed and parking brake of the rider. The left lever controls the left rear drive wheel and the right lever controls the right rear drive wheel and parking brake.

Pushing the levers out to the side, away from the operator's lap, locks the parking brake in PARK position (inset, Figure 1). This is the proper position for starting the rider. Pulling the levers in across the operator's lap puts the levers in DRIVE positions.

From DRIVE position, moving a lever forward increases the FORWARD speed of the associated wheel. Pulling back on a lever increases the REVERSE speed. The further a lever is pushed, the faster the drive wheel will turn.

See DRIVING PRACTICE for steering instructions.

Engine Speed Control

The engine speed control adjusts engine speed. Always set the engine speed to FAST for driving and mowing. Move the engine speed control back to SLOW to decrease engine speed. NEVER turn on the mower blades with the engine speed set to SLOW. Only turn on the mower blades with the engine speed set to FAST.

Choke

CLOSE the choke for cold starting (pull knob up). OPEN the choke once the engine starts (push knob down). If the engine is warm, it may not require choking. If this is the case, set the choke to OPEN (push the knob down) while cranking the engine. In most cases, you will need to close the choke in order to start the engine.



Mower Cutting Height Switch

To increase the mower cutting height (raise the mower deck), press the top of the yellow cutting height switch. To decrease mower cutting height (lower the mower deck), press the bottom of the switch. Mower cutting height range is approximately 3-3/4" to 1-1/2". The cutting height gauge indicates the position of the mower deck. The cutting height gauge is located on the front of the rider, just behind the driver's left leg.



Ignition Switch

The ignition switch starts and stops the engine; it has three positions:

- OFF** Stops the engine and shuts off the electrical system.
- RUN** Allows the engine to run and powers the electrical system.
- START** Cranks the engine for starting.

NOTE: Never leave the ignition switch in the RUN position with the engine stopped. This drains the battery.



Hour Meter

The hour meter measures the number of hours the key has been in the RUN position.

NOTE: The hour meter will register the passage of time when the key is in the RUN position, even if the engine is not running.



Mower Blade Switch

The yellow mower blade switch turns the mower blades on and off. To turn the mower blades ON, pull the switch up. To turn the mower blades OFF, push the switch down. Always set the engine speed control to FAST before turning the mower blades ON, and while mowing.



Transmission Release Levers

The transmission release levers deactivate the transmissions so that the unit can be pushed by hand. See PUSHING THE UNIT BY HAND for operational information.



Fuel Tank

To remove the fuel tank cap, turn it counterclockwise.

GENERAL OPERATING SAFETY

Before first time operation:

- Be sure to read all information in the Safety and Operation sections before attempting to operate this rider and mower.
- Become familiar with all of the controls and how to stop the unit.
- Drive in an open area without mowing to become accustomed to driving the unit.

WARNING

If you do not understand how a specific control functions, or have not yet thoroughly read the CONTROL FUNCTIONS section, do so now. Do NOT attempt to operate the rider without first becoming familiar with the location and function of ALL controls.

CHECKS BEFORE STARTING

- Check that the crankcase oil is filled to full mark on dipstick (see CHECK ENGINE OIL in the Maintenance section).
- Fill the fuel tank with fresh fuel.

FUEL RECOMMENDATIONS

For daily operation: Use only unleaded gasoline with a pump sticker octane rating of 87 or higher. Gasohol (up to 10% ethyl alcohol, 90% unleaded gasoline by volume) is approved as a fuel. Methyl Tertiary Butyl Ether (MTBE) and unleaded gasoline blends (up to a maximum of 15% MTBE by volume) are approved as a fuel. Do not use unapproved gasolines, such as E85. Do not mix oil in gasoline or modify the engine to run on alternate fuels. This will damage the engine components and void the engine warranty. Do not use fuel additives other than fuel stabilizer.

For storage: CAUTION: Alcohol blended fuels (called gasohol or using ethanol or methanol) can attract moisture which leads to separation and formation of acids during storage. Acidic gas can damage the fuel system of an engine while in storage.

To avoid engine problems always use fuel stabilizer, especially before storage of 30 days or longer. Use fresh fuel next season. See STORAGE instructions for additional information.

Never use engine or carburetor cleaner products in the fuel tank or permanent damage may occur. To add fuel:

1. Remove the fuel cap (B, Figure 2).
2. Fill the tank. Do not overfill. Leave 2 inches (5 cm) of space in the tank for fuel expansion.
3. Install and hand tighten the fuel cap.

⚠ WARNING

Never allow passengers to ride on the unit.

Before leaving the operator's position for any reason, engage the parking brake and disengage the PTO. Never leave the unit unattended (i.e. out of sight) with the engine running.

To reduce fire hazard, keep the engine, rider and mower free of grass, leaves and excess grease. Do not stop or park rider over dry leaves, grass or combustible materials.

Gasoline is highly flammable and must be handled with care. Never fill the tank when the engine is still hot from recent operation. Do not allow open flame, smoking or matches in the area. Avoid over-filling and wipe up any spills.

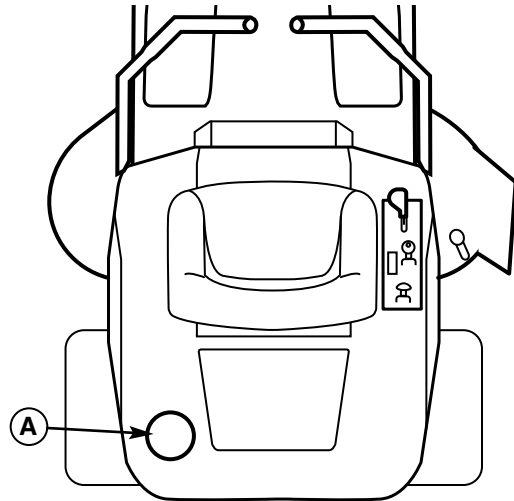

Figure 2. Pre-Start Checks
A. Fuel Tank Cap

⚠ WARNING

Never operate on slopes greater than 17.6 percent (10°) which is a rise of 3-1/2 feet (106 cm) vertically in 20 feet (607 cm) horizontally.

Select slow ground speed before driving onto a slope. Use extra caution when operating on slopes with a rear-mounted grass catcher.

Mow up and down the face of slopes, not across. Use caution when changing directions and DO NOT START OR STOP ON A SLOPE.

⚠ WARNING - TRAILERS

Do not load this zero-turn rider on a trailer or truck using two separate ramps. Only use a single ramp that is at least one foot wider than the width of the rear wheels of this rider. This rider has a zero turning radius and the wheels could fall off the ramps, or the rider could tip over injuring the operator or bystanders.



EMERGENCY STOPPING

In the event of an emergency the engine can be stopped by simply turning the ignition switch to STOP. Use this method only in emergency situations. For normal engine shut down follow the procedure given in STOPPING THE RIDER AND ENGINE.

STOPPING THE RIDER & ENGINE

1. Return the ground speed control levers to START/PARK positions to stop rider movement and engage the parking brake.
2. Turn off the mower blades by pushing the mower blade switch down to the OFF position.
3. Move the engine speed control to SLOW position and turn the ignition switch to OFF. Remove the key.

STARTING THE ENGINE

1. While sitting in the seat, make sure the mower blade switch is OFF and the ground speed control levers are locked in START/PARK positions.
2. Move the engine speed control fully forward to FAST. Set the choke control to CLOSED (pull knob UP).

NOTE: A warm engine may not require choking. In this case, set the choke control to OPEN (push knob down).

3. Insert the key into the ignition switch and turn it to START to crank the engine.
4. After the engine starts, release the key. It will return to the RUN position. Gradually push the choke knob down to OPEN position. Warm the engine by running it for at least a minute before turning on the mower blades, or driving the unit.

ALWAYS operate the unit with the engine speed control set to FAST when mowing or driving.
NEVER engage the mower blades with the engine speed set to SLOW.

MOWING

1. Start the engine (see STARTING THE ENGINE).
2. Set the mower cutting height to the desired setting using the mower cutting height switch.
3. Set the engine speed control to FAST.
4. Turn the mower blades ON (pull switch up).
5. Move the ground speed control levers in from START/PARK positions to drive positions (levers in across the operator's lap).
7. Begin mowing. See DRIVING PRACTICE.
8. When finished, turn the mower blades OFF (push switch down).
9. Stop the rider and engine (see STOPPING THE RIDER AND ENGINE).

PUSHING THE RIDER BY HAND

NOTE: Do not disengage the transmissions if parked on a slope.

1. Turn the mower blades OFF, push the ground speed control levers out to their START/PARK positions, turn the ignition switch OFF, **remove the key**, and wait for all moving parts to stop.
2. Locate the transmission release levers (C, Figure 3) at the rear of the unit.
3. Pull **both** levers back and down to release the transmissions (position B, Figure 3).
4. Pull the ground speed control levers in to their DRIVE positions.

The rider can now be pushed by hand.

5. After moving the rider, set the ground speed control levers to START/PARK and push **both** transmission release levers forward to re-engage the transmissions (position A, Figure 3).



DO NOT TOW RIDER

Towing the unit will cause transmission damage. Do not use another vehicle to push or pull this unit. Do not use this unit to push or pull another vehicle or object.

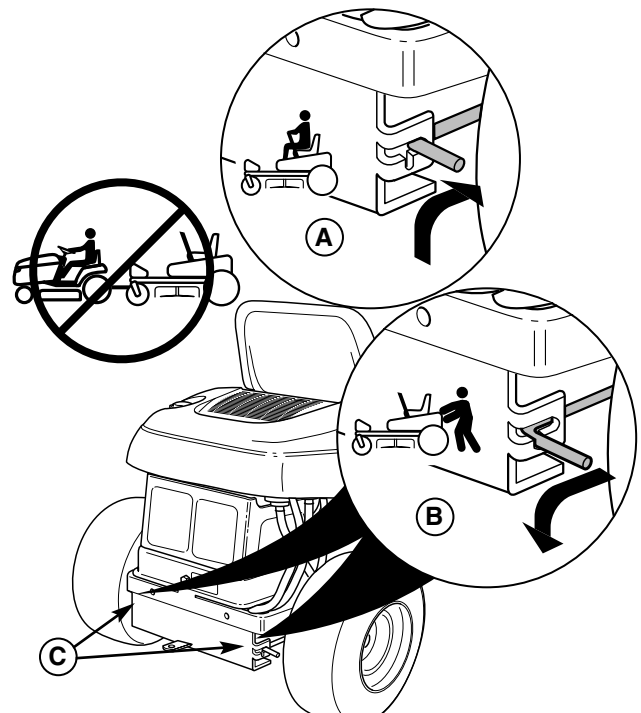

Figure 3. Transmission Release Levers

A. Drive Position

B. Push Position

C. Transmission Release Levers

DRIVING PRACTICE - BASIC DRIVING

WARNING: Never operate on slopes greater than 17.6% (10°). See SLOPE OPERATION in the safety section. Zero turn riders operate differently from other four-wheeled vehicles. The drive wheels are also your steering wheels. If you cannot drive the unit on a hill, you will not be able to steer the unit on it. Operating zero turn units on slopes requires extra caution.

The lever controls of the zero turn rider are very responsive, and learning to gain a smooth and efficient control of the rider's forward, reverse, and turning movements will take some practice.

Spend some time going through the following maneuvers and becoming familiar with how the unit accelerates, travels, and steers — before you begin mowing — is absolutely essential to getting the most out of the zero turn rider.

Avoid turf damage! To avoid turf damage, keep both drive wheels moving while executing turns. Pivoting on one wheel, or dragging a wheel through a turn will damage your lawn.

Locate a smooth, flat area of your lawn — one with plenty of room to maneuver. (Clear the area of objects, people and animals before you begin.) Operate the unit at mid-throttle during this practice session (ALWAYS operate at full throttle when mowing), and turn slowly to prevent tire slippage and damage to your lawn.

We suggest you begin with the Smooth Travel procedure to the right, and then advance through the forward, reverse, and turning maneuvers.

⚠ WARNING

Do not mow in reverse unless absolutely necessary. Always look down and behind before and while traveling in reverse.

Smooth Travel

The lever controls of the zero turn rider are highly responsive.

The BEST method of handling the ground speed control levers is in three steps — as shown in Figure 4.

FIRST place your hands onto the levers as shown.

SECOND, to go forward gradually push the levers forward with your palms.

THIRD, to speed up move the levers farther forward. To slow down smoothly, slowly move the levers back toward neutral.

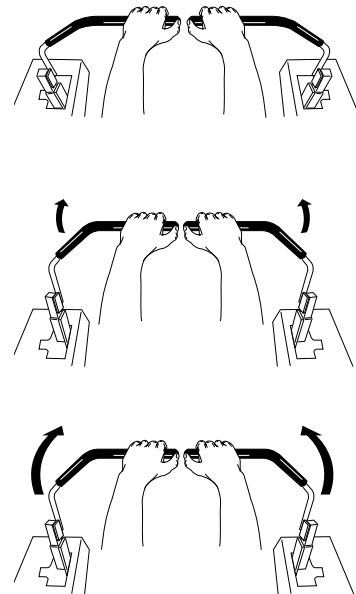

Figure 4. Move Control Levers Gradually

Forward Travel Practice

Gradually move both ground speed control levers evenly FORWARD from neutral. Slow down and repeat.

Reverse Travel Practice

LOOK DOWN & BEHIND, then gradually move both ground speed control levers evenly BACK from neutral. Slow down and repeat.

NOTE: Practice backing up for several minutes before attempting to do so near objects. The rider turns as sharply in reverse as when going forward, and backing up straight takes practice.

Forward Travel

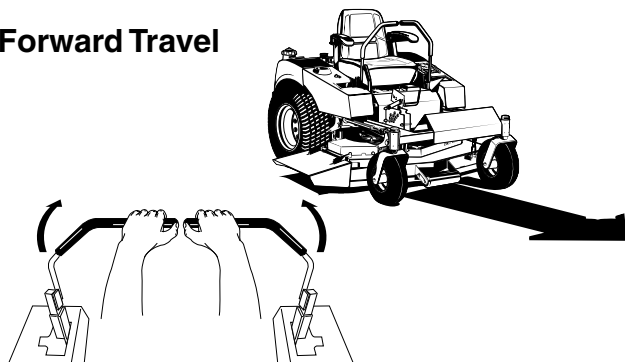

Figure 5. Forward Travel

Reverse Travel

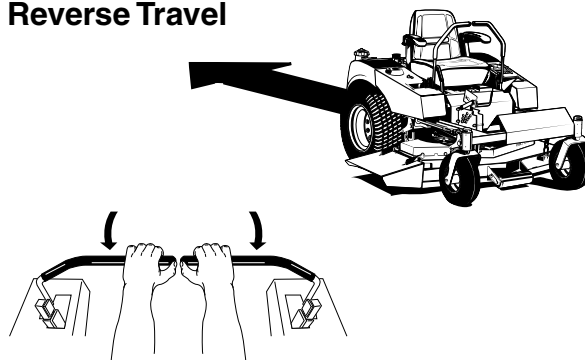

Figure 6. Reverse Travel

Practice Turning Around a Corner

While traveling forward allow one handle to gradually return back toward neutral. Practice several times before mowing.

NOTE: To prevent damaging your lawn by pivoting directly on the tire tread, it is best to keep both wheels going at least slightly forward.

Executing Turns

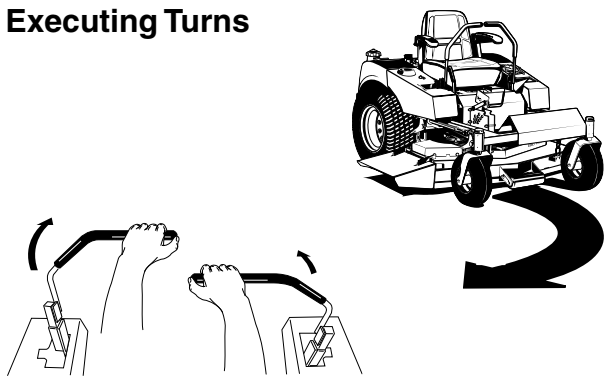

Figure 7. Right Turn

Practice Turning In Place

To “zero turn” means to turn in place. To turn in place, gradually move one ground speed control lever forward from neutral and one lever back from neutral simultaneously. Repeat several times.

Turning In Place

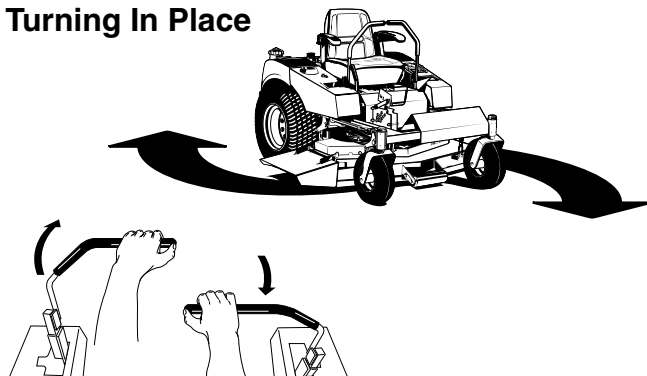

Figure 8. Turning in Place

ADVANCED DRIVING

Executing an End-Of-Row Zero Turn

Your zero turn rider's unique ability to turn in place allows you to turn around at the end of a cutting row rather than having to stop and make a Y-turn before starting a new row.

For example, to execute a right end-of row zero turn:

1. Slow down at the end of the row.
2. Move the LEFT ground speed control lever forward slightly while moving the RIGHT ground speed control lever back to center and then slightly back from center. Be sure to keep both wheels moving to avoid turf damage.
3. Begin mowing forward again.

This technique turns the rider RIGHT and slightly overlaps the row just cut —eliminating the need to back up and re-cut missed grass.

As you become more familiar and experienced with operating the zero turn rider, you will learn more maneuvers that will make your mowing time easier and more enjoyable.

Remember, the more you practice, the better your control of the rider will be!

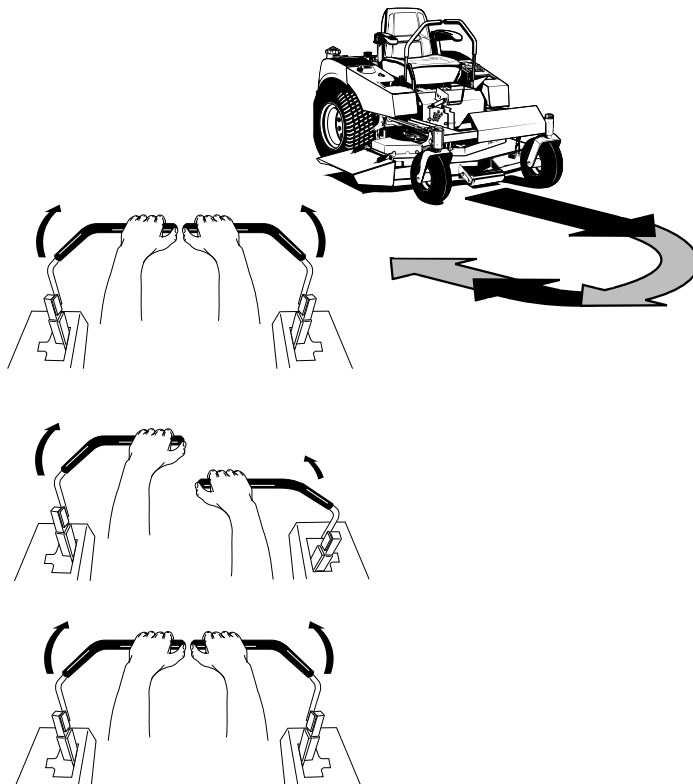

Figure 9. Executing an End-Of-Row Turn

MOWER DECK REMOVAL & INSTALLATION

NOTE: Perform mower removal and installation on a hard, level surface such as a concrete floor.

⚠ WARNING

After lowering the mower cutting height, engage parking brake, turn off the mower blades, turn the ignition switch to STOP, and remove key before attempting to install or remove the mower.

Removing the Mower Deck

1. Turn the mower blades OFF, put the ground speed control levers in START/PARK position, turn the ignition OFF, and wait for all moving parts to stop.
2. Pivot the front wheels forward.
3. Use the mower belt release lever (D, Figure 11) to release belt tension. Remove the mower belt from engine pulley (A).
4. Turn the ignition switch from OFF to RUN without starting the engine.
5. Use the mower cutting height switch to raise the mower deck.
6. Place 4x4 wood blocks (D, Figure 10) under the front and rear lip of the mower deck to securely support it.
7. Use the mower cutting height switch to fully lower the mower so that it is resting on the 4x4 wood blocks.
8. Turn the ignition switch to OFF and remove the key.
9. Remove the hair pin clip (A) securing the rear mower lift arm. Separate the lift arm from the mower deck. Repeat on both sides of the mower.
10. Remove the hitch rod (C) from the hitch bracket.
11. Slide the mower deck out from under the rider.

Installing the Mower Deck

1. Slide the mower deck under the right side of the rider. Slide the mower forward and hook the front hitch rod (C, Figure 10) to the front mower deck hooks.
2. Slide the mower deck backwards and connect the rear lift arms to the mower deck. Secure with hair pin clips (A).
3. Insert the key into the ignition switch. Turn the switch from OFF to RUN without starting the engine.
4. Use the cutting height switch to raise the mower until it is no longer resting on the 4x4 wood blocks (D).
5. Turn the ignition switch OFF and remove the key. Remove the 4x4 blocks (D).
6. Use the mower belt release lever to release mower belt tension, and install the belt as shown in Figure 11.

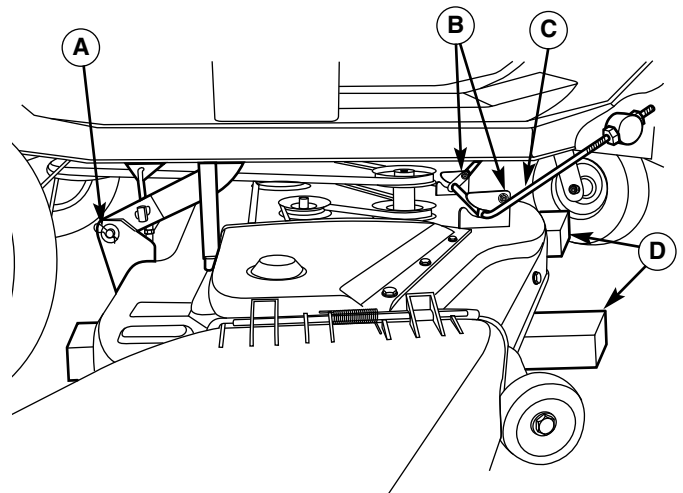

Figure 10. Mower Hitch Components
A. Hair Pin Clip
B. 3/8-16 x 3/4 Carriage Bolt & Flange Nut
C. Hitch Rod
D. 4x4 Wood Blocks

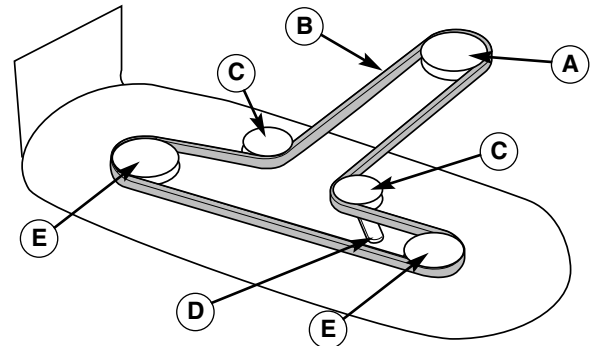

Figure 11. Mower Belt Routing
A. Engine Pulley
B. Mower Drive Belt
C. Back-Side Idler Pulleys
D. Mower Belt Release Lever
E. Arbor Pulleys

MAINTENANCE

MAINTENANCE SCHEDULE

The following schedules should be followed for normal care of your rider and mower.

RIDER MAINTENANCE, All Models	Before Each Use	Spring & Fall	8 Hours	25 Hours	100 Hours	200 Hours	Yearly
Clean Debris from Rider and Engine Compartment *	•						
Clean Debris from Engine Cooling Areas & Air Filter *	•						
Check Tire Pressure				•			
Lubricate Rider & Mower *				•			
Clean Deck & Check/Replace Mower Blades				•			
Clean Battery & Cables					•		
Check Rider Safety System **		•			•		•
Check / Adjust PTO Clutch						•	

ENGINE MAINTENANCE, 20HP Briggs & Stratton	8 Hours or Daily	25 Hours or Every Season	50 Hours or Every Season	100 Hours or Every Season	Yearly
Check Engine Oil Level *	•				
Service Air Pre-Cleaner *		•			
Change Oil *			•		
Service Air Filter *			•		
Change Oil & Filter *				•	
Clean Cooling Fins *				•	
Replace Air Filter *				•	
Replace Spark Plug				•	
Replace Fuel Filter †				•	
Check Valve Clearance †					•

* More often in hot (over 85° F: 30° C) weather or dusty operating conditions.

** Check the function of the safety system after the unit has been stored for 30 days or longer.

† These services should be performed by your dealer.

Rider Maintenance Items

WARNING

Move the ground speed levers to **START/PARK** positions, turn the mower blades **OFF**, turn the ignition switch **OFF**, and wait for all moving parts to stop before accessing the engine compartment or performing any maintenance procedures.

ACCESSING THE ENGINE COMPARTMENT

Lift up on the back edge of the seat deck to access the engine compartment.

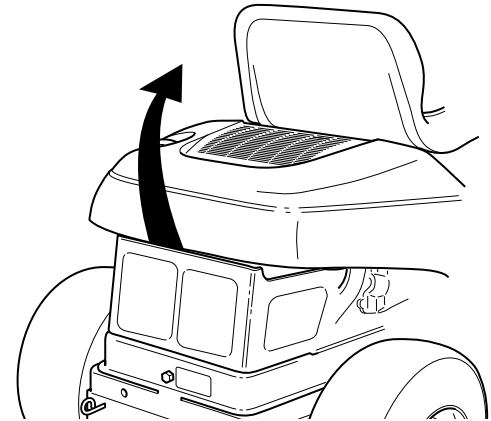

Figure 12. Accessing the Engine Compartment

CLEAN DEBRIS FROM RIDER AND ENGINE COMPARTMENT

Service Interval: Before each use.

CAUTION: If debris is not removed from the engine compartment and other hot surfaces, it creates a fire hazard. Before starting the unit at the beginning of the mowing session, remove any grass clippings, dirt, leaves, or other debris from the unit. Also clean out the engine compartment.

CLEAN DEBRIS FROM ENGINE COOLING AREAS AND AIR FILTER

Service Interval: Before each use.

CAUTION: If debris is not removed from the engine compartment and other hot surfaces, it creates a fire hazard. Before starting the unit at the beginning of the mowing session, lift the seat deck and clean any debris from the intake screen on top of the engine (A, Figure 13), exposed engine cooling fins, and around the air filter assembly. Also open the air filter cover (B) and remove any debris that has accumulated in the air filter compartment.

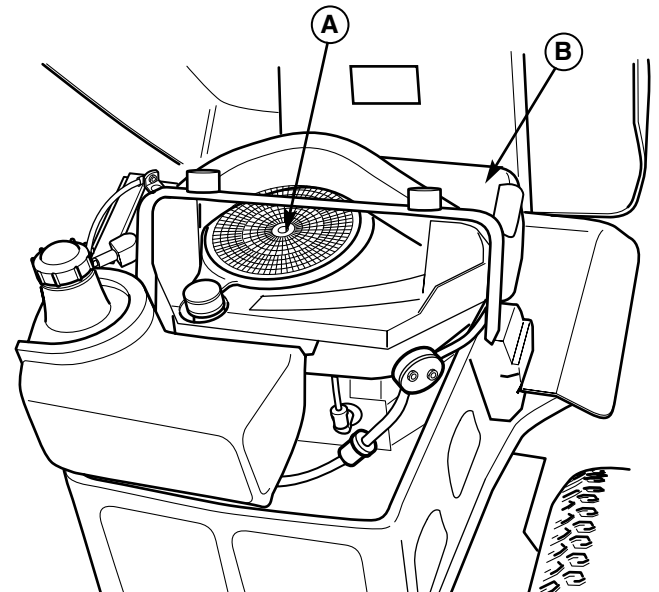
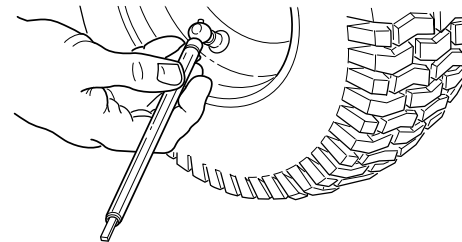

Figure 13. Engine Compartment
A. Intake Screen
B. Air Filter Cover

CHECK TIRE PRESSURE

Service Interval: 25 Hours.

Tire pressure should be checked periodically, and maintained at the levels shown in Figure 14. Note that these pressures may differ slightly from the “Max Inflation” stamped on the side-wall of the tires. The pressures shown provide proper traction, improve cut quality, and extend tire life.



Tire	Pressure
Front	18-20 psi (1,24-1,38 bar)
Rear	10-12 psi (.69-.83 bar)

Figure 14. Tire Pressures

LUBRICATION

Service Interval: 25 hours.

Lubricate the unit at the locations shown in Figures 15 through 19 as well as the following lubrication points.

Grease:



- front wheel grease fittings
- front wheel bushings
- mower pivots
- mower arbors

Use grease fittings when present.

Not all greases are compatible. Use automotive-type lithium grease.

Oil:



- hydro linkage
- brake linkage
- mower deck height adjustment linkage
- ground speed control linkage

Generally, all moving metal parts should be oiled where contact is made with other parts. Keep oil and grease off belts and pulleys. Remember to wipe fittings and surfaces clean both before and after lubrication.

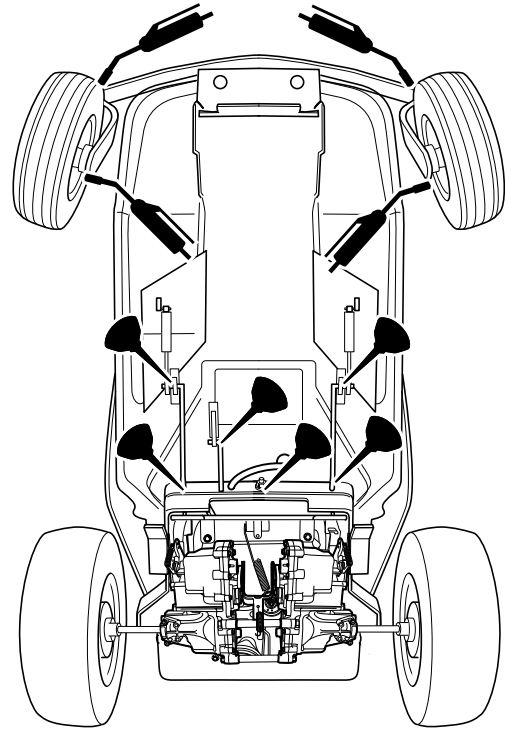

Figure 17. Lubricating Rider

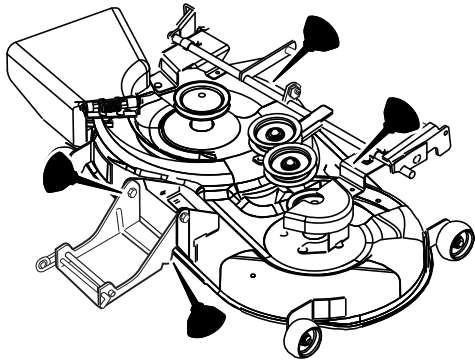

Figure 15. Mower Lubrication

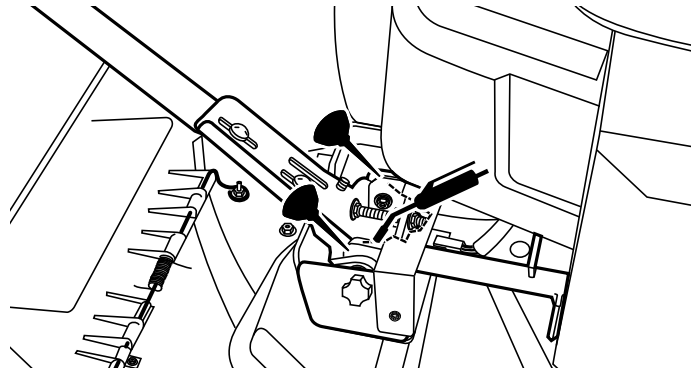

Figure 18. Lubricating Rider

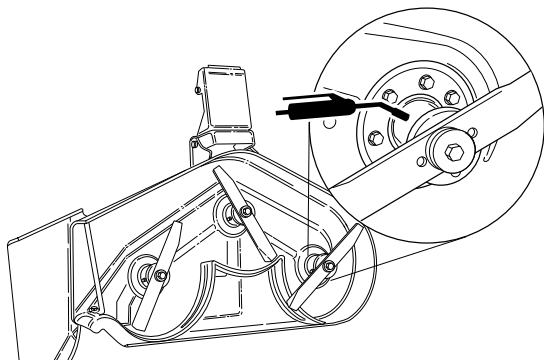

Figure 16. Arbor Lubrication (3-Blade Model Shown)

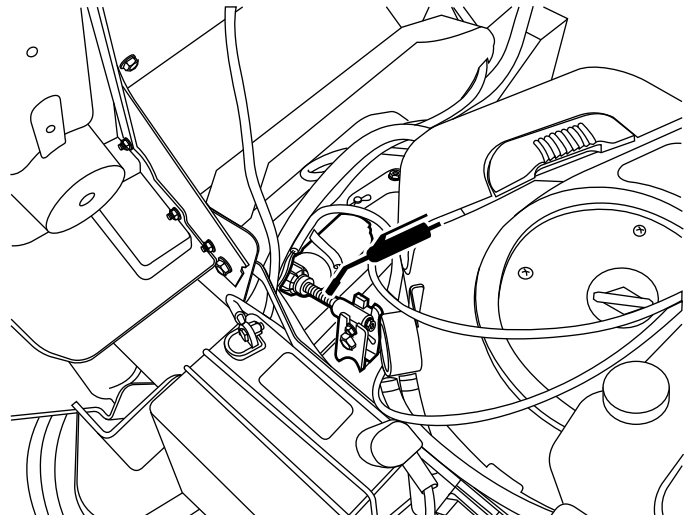

Figure 19. Lubricating Mower Lift

CLEAN DECK & CHECK / REPLACE MOWER BLADES

Service Interval: 25 hours or as required.

⚠ WARNING

For your personal safety, do not handle the sharp mower blades with bare hands. Careless or improper handling of blades may result in serious injury.

⚠ WARNING

For your personal safety, blade mounting capscrews must each be installed with two spring washers or a hex washer and spring washer, then securely tightened. Torque blade mounting nut to 80 - 90 ft. lbs. (108 - 122 Nm).

1. Remove mower deck (see "Mower Deck Removal" in the OPERATION section).
2. See Figure 20. Remove blade to inspect it or to safely access the underside of the mower deck. Use a block of wood to prevent blade rotation while loosening the capscrew by turning it counterclockwise.
3. Remove the capscrew (D, Figure 22), spring washer (C), hex washer (B), and blade.
4. Clean the underside of the mower deck.
5. Inspect the blades for nicks or dull edges. Use a file to sharpen blade to a fine edge. If the blade is damaged, it must be replaced.
6. Balance the blade as shown in Figure 21. Center the blade's hole on a nail lubricated with a drop of oil. A balanced blade will remain level. If the blade is not balanced, continue to sharpen the heavy side until it balances.
7. Reinstall the blade with the lift wings (D, Figure 22) pointing up toward the mower deck as shown.
8. Reinstall the spring washers (B, Figure 22) and nut (C). Use a wooden block (A) to prevent blade rotation while tightening the nut (C) to 80-90 ft. lbs. (108-122 Nm).

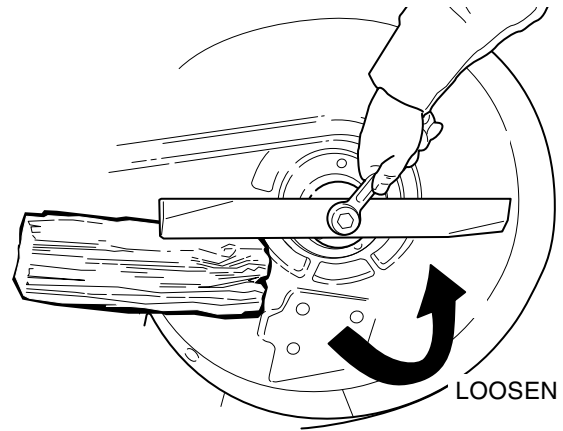

Figure 20. Blade Removal

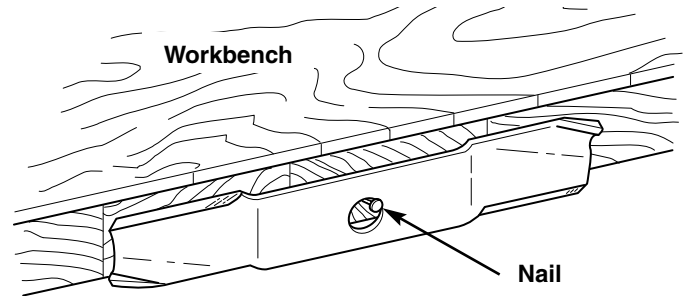

Figure 21. Balancing The Blade

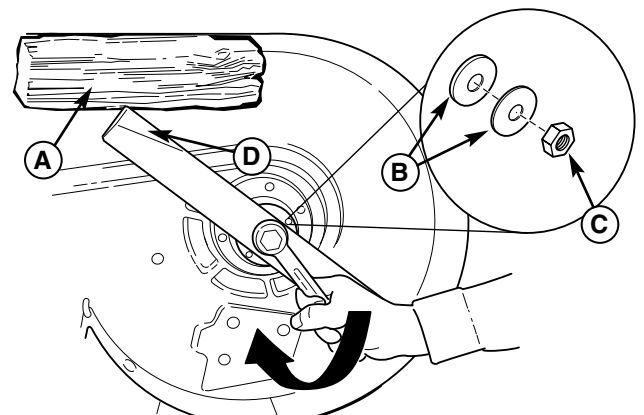

Figure 22. Blade Installation

A. 4x4 Wood Block
B. Spring Washers

C. Blade Nut
D. Lift Wings

CLEAN THE BATTERY AND CABLES

Service Interval: 100 Hours

WARNING

Be careful when handling the battery. Avoid spilling electrolyte. Keep flames and sparks away from the battery.

When removing or installing battery cables, disconnect the negative cable **FIRST** and reconnect it **LAST**. If not done in this order, the positive terminal can be shorted to the frame by a tool.

Always wear safety glasses and gloves when handling batteries.

1. Disconnect the cables from the battery, negative cable first (B, Figure 23).
2. Remove the rubber strap securing the battery, and remove the battery.
3. Clean the battery and battery compartment with a solution of baking soda and water.
4. Clean the battery terminals and cable ends with a wire brush until shiny.
5. Reinstall the battery and secure with the rubber strap.
6. Reattach the battery cables: first attach the positive cable (see A, Figure 23), then attach the negative cable (B).
7. Coat the cable ends and battery terminals with petroleum jelly or non-conducting grease.

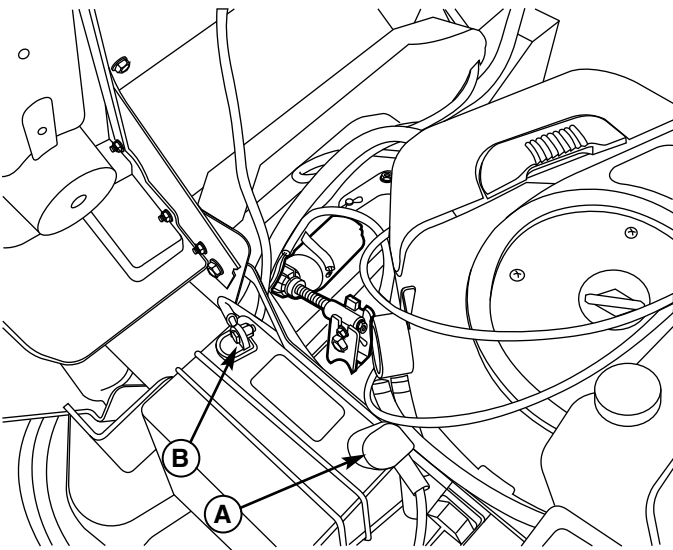

Figure 23. Engine Compartment
A. Positive (+) Battery Cable
B. Negative (-) Battery Cable



CHECK RIDER SAFETY SYSTEM

Service Interval: Every 100 hours, every spring/fall, and after storage of 30 days or longer.

This unit is equipped with safety interlock switches. These safety systems are present for your safety. Do not attempt to bypass safety switches, and never tamper with safety devices. Check their operation regularly.

Operational SAFETY Checks

TEST 1 — ENGINE SHOULD NOT CRANK IF:

- Mower blades switch is ON, OR
- Ground speed control levers are not in their START/PARK positions.

TEST 2 — ENGINE SHOULD CRANK IF:

- Mower blade switch is OFF, AND
- Ground speed control levers are in their START/PARK positions.

TEST 3 — ENGINE SHOULD SHUT OFF IF:

- Operator rises off seat with the mower blade switch ON, OR
- Operator rises off seat with the ground speed levers in DRIVE positions, OR
- Operator moves the left ground speed control lever out of its START position while leaving the right lever in START/PARK (both levers must be moved from START to DRIVE position simultaneously to avoid shutoff).

TEST 4 — BLADE BRAKE CHECK

The mower blades and mower drive belt should come to a complete stop within five seconds after the mower blade switch is turned OFF. If mower drive belt does not stop within five seconds, contact your local authorized dealer.

NOTE: Once the engine has stopped, the mower blade switch must be turned OFF and the ground speed control levers must be locked in their START/PARK positions in order to start the engine.

WARNING

If the unit does not pass a safety test, do not operate it. See your local authorized dealer. Under no circumstance should you attempt to defeat the purpose of the safety interlock system.

CHECK / ADJUST PTO CLUTCH

⚠ WARNING

To avoid serious injury, perform adjustments only with engine stopped, key removed and tractor on level ground.

Service Interval: 200 Hours.

The Power Take Off (PTO) clutch drives the mower blades. The PTO clutch is engaged and disengaged by the mower blade switch. Check the PTO clutch adjustment every 200 hours of operation. Also perform the following procedure if the clutch is slipping, will not engage, or if a new clutch has been installed.

1. Remove key from ignition switch and disconnect spark plug wires to prevent the possibility of accidental starting while the PTO is being adjusted.
2. See Figure 24. Note the position of the 3 adjustment windows (A) in the side of the brake plate and the nylock adjustment nuts (B).
3. Insert a .012"-.015" (2,5-4mm) feeler gauge (C) through each window, positioning the gauge between the rotor face and the armature face as shown in Figure 25.
4. Alternately tighten the adjustment nuts (B, Figure 24) until the rotor face and armature face just contacts the gauge.
5. Check the windows for an equal amount of tension when the gauge is inserted and removed, and make any necessary adjustments by tightening or loosening the adjustment nuts.

NOTE: The actual air gap between the rotor and armature may vary even after performing the adjustment procedure. This is due to dimensional variations on component parts, and is an acceptable condition.

6. Check the mower blade stopping time. The mower blades and mower drive belt should come to a complete stop within five seconds after the electric PTO switch is turned off. If adjustment does not stop a mower braking problem, replace the electric PTO clutch.

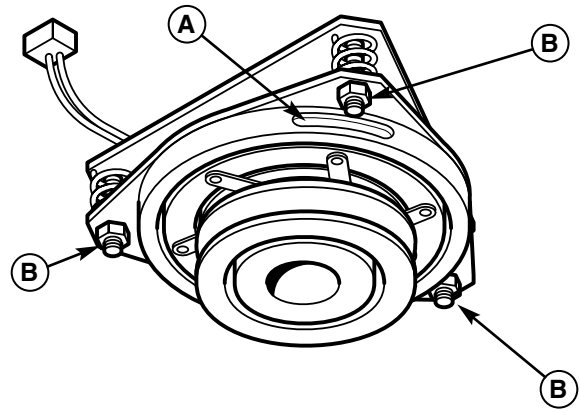

Figure 24. PTO Clutch Adjustment
A. Adjustment Window (Qty. 3, one shown)
B. Adjustment Nut

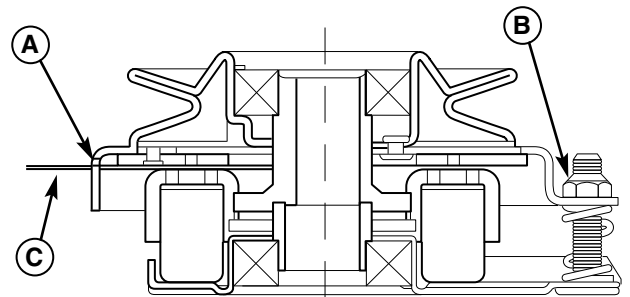

Figure 25. Adjust PTO Clutch
A. Window
B. Adjustment Nut
C. Feeler Gauge

Engine Maintenance Items

CHECK ENGINE OIL LEVEL

Service Interval: Before each use, and every 8 hours.

1. Turn the engine off, and set the parking brake to PARK.
2. Clean the area around the dip stick (C, Figure 27).
3. Remove the dip stick (C) and clean it with a paper towel.
4. Insert the dip stick back into the engine. Thread the cap back into the tube (D).
5. Remove the dip stick and read the oil level. The oil level should be between the "FULL" and "ADD" marks (D). If not, add oil according to the oil recommendations chart (Figure 26).

CHANGE ENGINE OIL

Service Interval: 50 hours or once per season.

Oil Capacity: Approximately 44 ounces (1.3L) without filter change. If changing oil without changing the filter, use the engine oil dip stick to determine oil level.

NOTE: Change engine oil while the engine is warm. Run the engine for a few minutes, then shut the engine off and allow it to cool from hot to warm.

1. Clean the area around the dip stick (C, Figure 27) and oil drain tube (A).
2. Remove the oil drain plug (A) from the end of the oil drain tube. Remove the dip stick (C). Allow ample time for complete drainage.
3. Reinstall the oil drain plug (A) and route the hose next to the engine.
4. Fill the crankcase with oil. See CHECK ENGINE OIL LEVEL above.
5. Start and run the engine at SLOW speed for 30 seconds. Stop the engine and recheck the oil level.

CHANGE ENGINE OIL & FILTER

Service Interval: 100 hours or once per season.

Oil Capacity: 48 ounces (1.42L) with oil filter change.

NOTE: Change engine oil while the engine is warm. Run the engine for a few minutes, then shut the engine off and allow it to cool from hot to warm.

1. Clean the area around the dip stick (C, Figure 27) and oil drain (A).
2. Remove the oil drain plug (A) and dip stick (C). Allow ample time for complete drainage.
3. Remove the oil filter (B). Discard the filter.
4. Using a drop of oil on your finger tip, wet the rubber gasket on the bottom of the new filter.

Use oil classified API Service Class SF, SG, SH, SJ or better with SAE Viscosity:

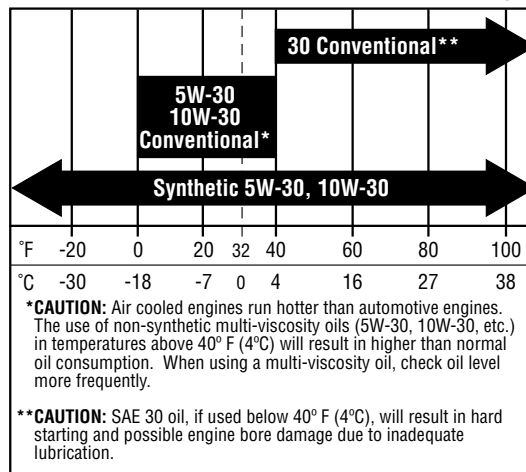

Figure 26. Recommended Engine Oil - Briggs & Stratton Models

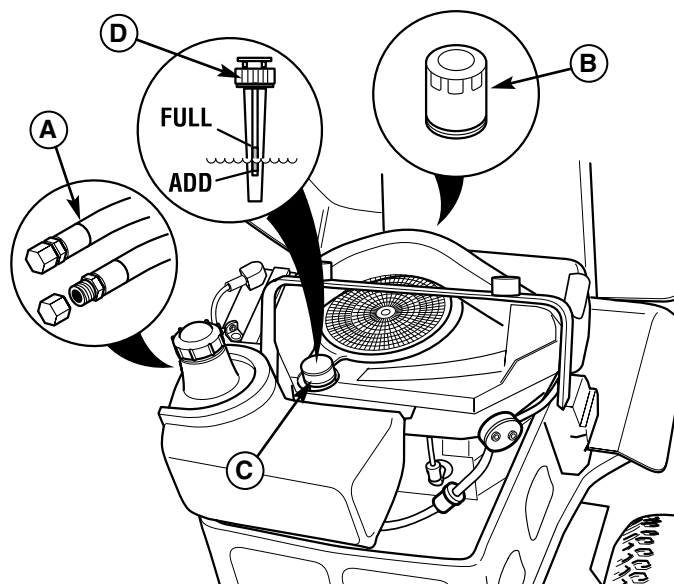

Figure 27. Oil Change - Briggs & Stratton Models
A. Oil Drain Tube
B. Oil Filter
C. Dip Stick
D. Checking Oil Level

6. Turn the filter clockwise until the rubber gasket meets the filter base. Then turn 1/2 to 3/4 turn more.
7. Reinstall the oil drain plug (A).
8. Fill the crankcase with oil. See CHECK ENGINE OIL LEVEL above.
9. Start and run the engine at SLOW speed for 30 seconds. Stop the engine and recheck the oil level.
10. Test run the engine to check for leaks. Stop the engine for 1 minute, then recheck the oil level.

SERVICE AIR FILTER & PRE-CLEANER

Service Interval: Pre-Cleaner: Every 25 hours or as required. Air Filter: Every 50 hours or as required.

Replacement Interval: Pre-Cleaner: As required. Air Filter: Every 200 hours or once per season.

Air Filter Removal & Installation

1. Lift up on the bottom of the latch (A, Figure 28 or 29) and flip the latch away from the cover.
2. Remove the cover (B). Remove the filter (C, Figure 27) and pre-cleaner (D).
3. Install the pre-cleaner (D) with the mesh side up. Install the filter (C) as shown.
4. Install the cover (B, Figure 29) making sure the tabs are inserted into their slots. Secure with the latch (A).

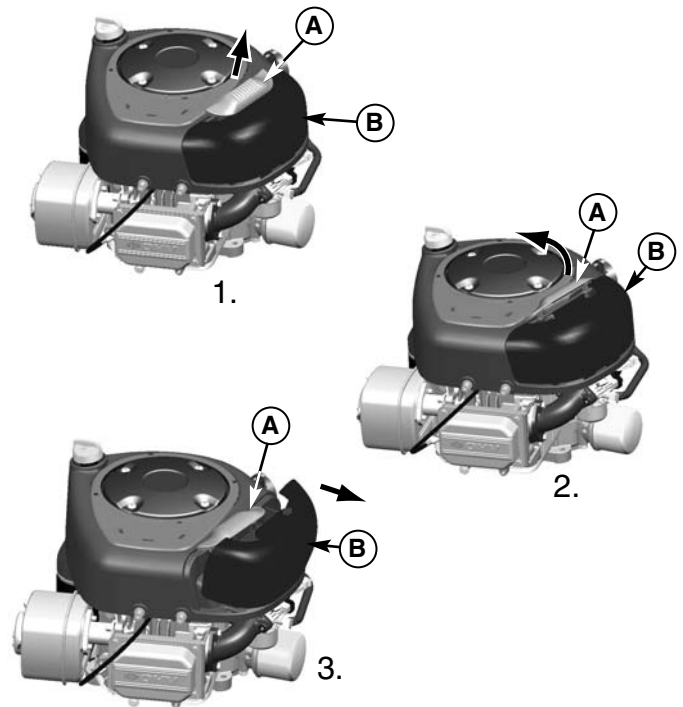

Figure 28. Air Filter Assembly - Briggs & Stratton Single Cylinder Models
A. Air Filter Latch
B. Air Filter Cover

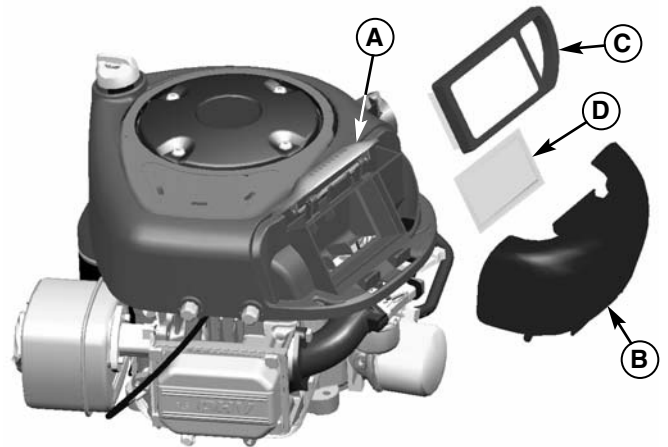

Figure 29. Air Filter Service - Briggs & Stratton Single Cylinder Models
A. Air Filter Latch
B. Air Filter Cover
C. Air Filter
D. Pre-Cleaner

Pre-Cleaner Service

NOTE: Replace a worn or damaged pre-cleaner.

1. Figure 30. Wash the pre-cleaner in liquid detergent and water.
2. Squeeze the pre-cleaner dry and saturate with engine oil. Remove all excess oil by squeezing the pre-cleaner in an absorbent cloth.

Air Filter Service

NOTE: Replace a worn or damaged air filter.

1. Figure 30. If stamped "Washable," the filter can be washed with warm water and mild soap.
2. Rinse with tap water with the screen side UP allowing dirt and debris to filter out.
3. Allow the filter to dry overnight before reinstalling.

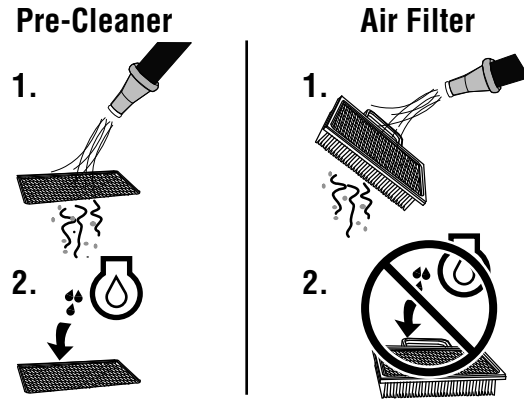

Figure 30. Air Filter Service

REPLACE SPARK PLUG

Service Interval: Yearly

Replacement Spark Plug: 5066

Spark Plug Gap: .030" (.76mm)

1. Stop the engine and allow it to cool.
2. Clean the area around the spark plug.
3. Remove the spark plug.
4. Check the spark plug gap. It should be .030" (see Figure 31).
5. Reinstall the plug into the cylinder head. Torque the plug to 180 in. lbs (20 N.m.).

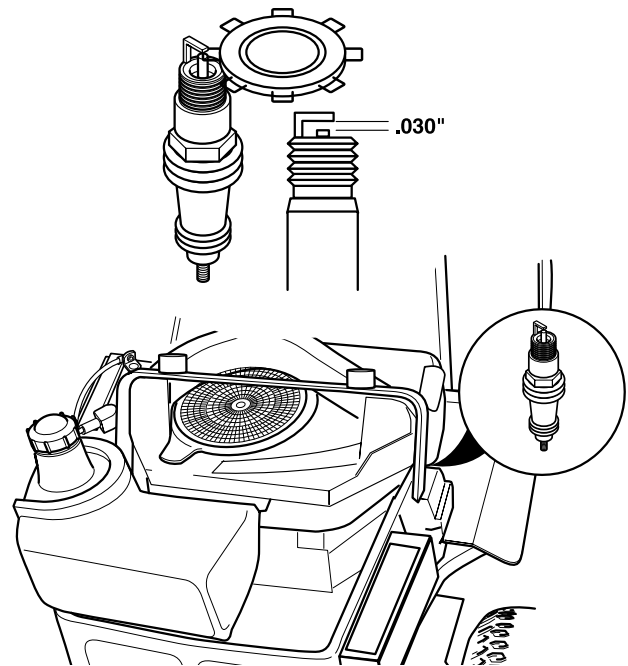

Figure 31. Spark Plug Gapping

SERVICE & ADJUSTMENTS

GROUND SPEED CONTROL LEVER ADJUSTMENT

The control levers have three adjustments:

To Adjust Control Lever Height: Pull the levers in across the operator's lap to their DRIVE positions. Loosen the mount bolts (D, Figure 32) and raise or lower the levers to the desired position. Tighten the mounting bolts.(D).

To Adjust Control Lever End Gap: The control lever end gap (C, Figure 33) should be adjusted so that the levers do not contact each other when placed in DRIVE positions. Loosen the jam nut (A, Figure 32) and adjust the length of the carriage bolt (B) so that the levers do not contact each other. Repeat on the opposite side. Tighten the jam nut (A) to lock the carriage bolt in position.

To Adjust Operator Clearance: The space between the operator and the control levers can be increase by removing the lower mounting bolt (D, Figure 32), pivoting the lever forward, and reinstalling the capscrew through the control lever and forward slot (C). Repeat with the other ground speed lever.

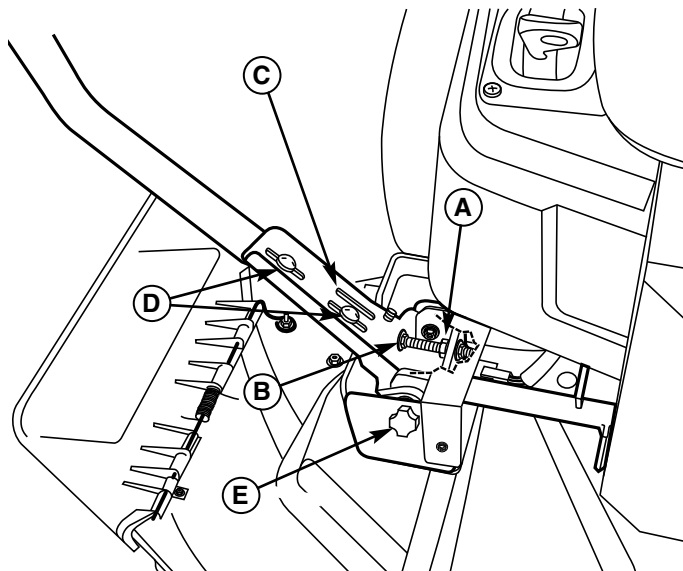

Figure 32. Control Lever Adjustment

- A. Jam Nut
- B. Carriage Bolt
- C. Forward Slot
- D. Mount Bolts
- E. Knob

SPEED BALANCING ADJUSTMENT

If the rider veers to the right or left when the ground speed control levers are in the maximum forward position, the top speed of the right lever can be balanced by turning the adjustment knob (E, Figure 32). Loosen the jam nut and turn the knob COUNTERCLOCKWISE to increase speed or CLOCKWISE to decrease speed. Tighten the jam nut when complete.

CUTTING HEIGHT ADJUSTMENT

To increase the mower cutting height (raise the mower deck), press the top of the mower cutting height switch (A, Figure 33) To decrease mower cutting height (lower the mower deck), press the bottom of the switch. Mower cutting height range is 3-3/4" to 1-1/2". The cutting height gauge indicates the position of the mower deck.. The cutting height gauge (B) is located on the front of the rider, just behind the driver's left leg.

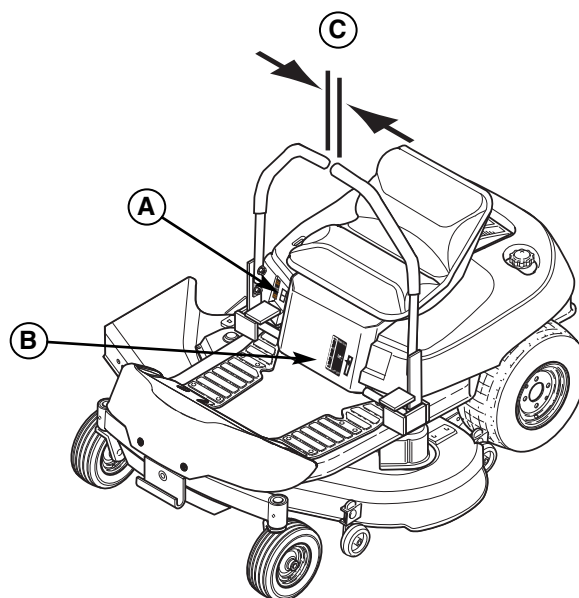

Figure 33. Cutting Height Adjustment

- A. Cutting Height Adjustment Switch
- B. Cutting Height Gauge
- C. Control Lever End Gap

PTO CLUTCH ADJUSTMENT

See CHECK / ADJUST PTO CLUTCH in the Maintenance Section.

BRAKE ADJUSTMENT

1. Stop the unit, turn the ignition OFF, set the ground speed levers to PARK positions, and wait for all moving parts to stop.
2. Locate the brake rod (A, Figure 34) and adjustment nut (B).
4. Measure the parking brake spring. Its compressed length, with the ground speed levers in their PARK positions should be 3" (7.62cm). Adjust the spring length by turning the adjustment nut (B), if necessary.

BATTERY CHARGING

WARNING



Corrosion hazard.

Batteries contain acid. Always keep the battery upright and do not spill the electrolyte. Avoid contact with skin and eyes.



Explosion hazard.

Changing the battery produces explosive hydrogen gas. Only charge the battery in a well ventilated area, away from any ignition source such as a water heater, electric motor, or a lit cigarette.



Wear Protective Equipment

Always wear gloves and safety glasses when handling the battery and battery cables.

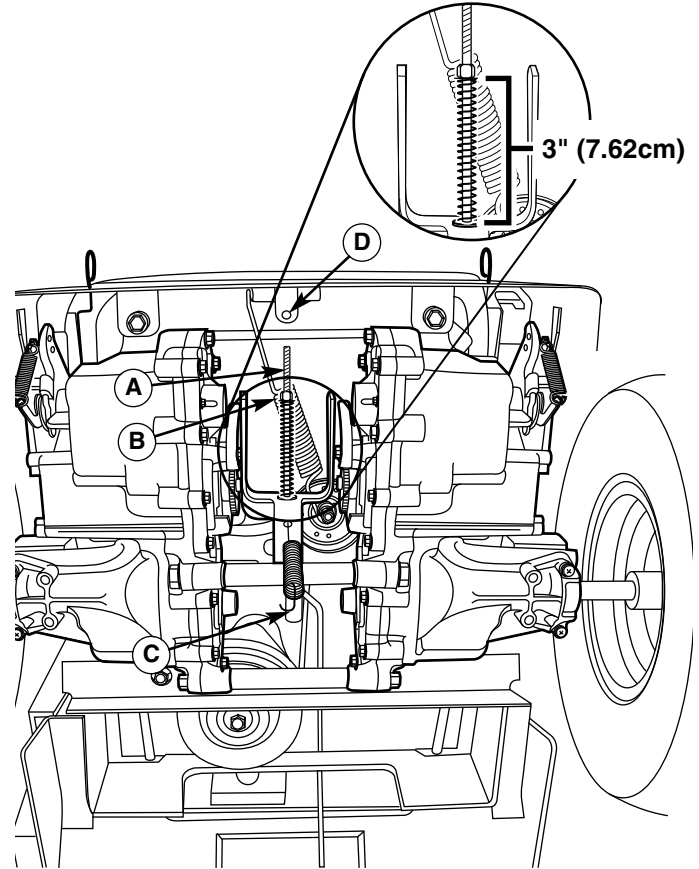

Figure 34. Brake Adjustment

- A. Brake Rod
- B. Adjustment Nut
- C. Return Spring (Removed for Illustration Only)
- D. Return Spring Hole

A dead battery or one too weak to start the engine may be the result of a defect in the charging system or other electrical component. If there is any doubt about the cause of the problem, contact your local dealer. If you need to replace the battery, follow the steps under Cleaning the Battery & Cables in the Regular Maintenance Section.

To charge the battery, follow the instructions provided by the battery charger manufacturer as well as all warnings included in the safety rules sections of this book. Charge the battery until fully charged (until the specific gravity of the electrolyte is 1.250 or higher and the electrolyte temperature is at least 60° F). Do not charge at a rate higher than 10 amps.

ENGINE ADJUSTMENTS

The engine is designed to deliver the correct performance under all operating conditions. Any adjustments must be performed by your local authorized dealer.

MOWER DECK LEVELING ADJUSTMENTS

WARNING

Before inspecting or adjusting the mower, turn the mower blades OFF, turn the ignition switch OFF, and allow all moving parts to stop. Remove ignition key, then disconnect the spark plug wire and fasten it away from the spark plug.

Side to Side Leveling

If the cut is uneven, the mower may need leveling. Unequal or improper tire pressure may also cause an uneven cut. See CHECK TIRE PRESSURE.

1. With the mower installed, place the rider on a smooth, level surface such as a concrete floor. Turn the front wheels straight forward. Turn the engine off, set the ground speed control levers to PARK, and wait for all moving parts to stop.
2. Check for bent blades and replace if necessary.
3. Check the tire pressures. See CHECK TIRE PRESSURE.
4. Set the cutting height to mid position. Arrange the mower blades so that they are pointing from side-to-side (Figure 36).
5. Measure the distance between the tips of the outside blades and the ground (Figures 35 & 36). If there is more than 1/8" (3mm) difference between the measurements on each side, proceed to step 6. If the difference is 1/8" (3mm) or less, proceed to Front To Back Leveling.
6. See Figure 37. Side-to-side leveling is accomplished using the threaded rods (A, Figure 37) and trunnion (B) on the right and left rear sides of the mower deck. Loosen the jam nuts (C) and adjust the nuts up or down to adjust the mower level. When complete, tighten the jam nuts against the trunnion to lock the adjustment in place.

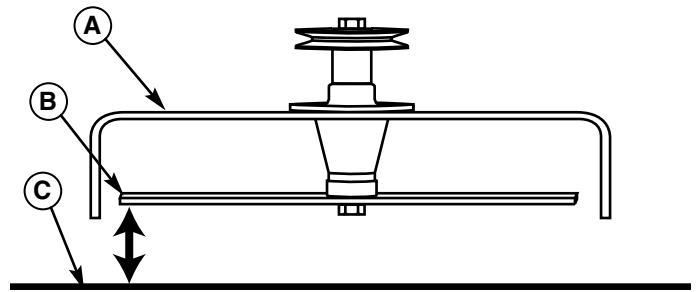

Figure 35. Measure Blade Tips to Ground

- A. Mower Deck
- B. Blade Tip
- C. Level Ground

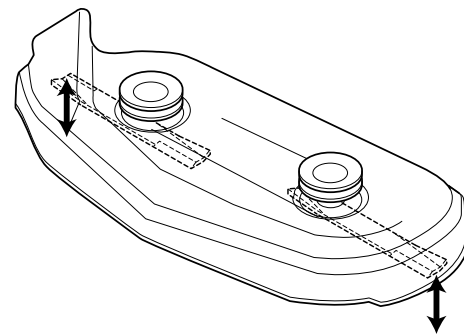

Figure 36. Orient Blades Side-to-Side

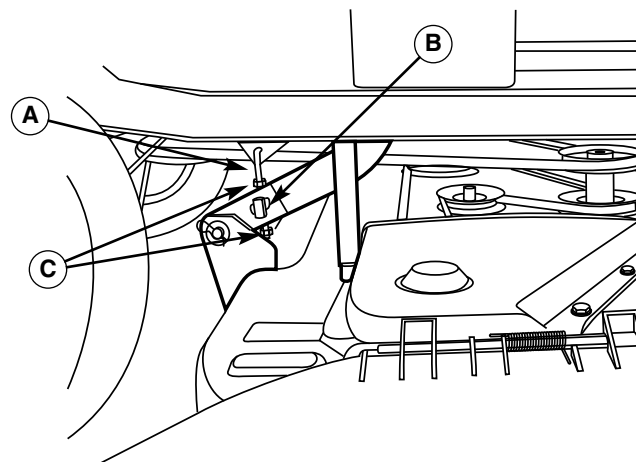

Figure 37. Side-to-Side Adjustment

- A. Threaded Rod
- B. Trunnion
- C. Jam Nuts

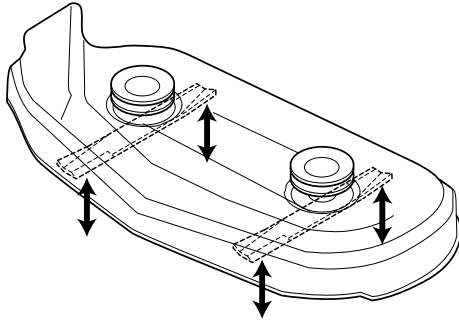

Figure 38. Orient Blades Front-to-Back

Front To Back Leveling

If the cut is uneven, the mower may need leveling. Unequal or improper tire pressure may also cause an uneven cut. See CHECK TIRE PRESSURE.

1. Turn the blades front-to-back as shown in Figure 38. Measure the distance from the ground to front tip of center blade, and from ground to rear tips of left hand and right hand blades (Figures 38). Front tips should be 1/8"-1/4" (3-6 mm) higher than rear tips. If not, proceed to step 2.
2. The front mower hitch rod (A, Figure 39) is used to adjust front-to-back leveling. To raise or lower the front of mower deck, loosen the two rear jam nuts (B) on both sides of the hitch rod (A). Adjust the front jam nuts (C) on both sides of the hitch rod (A) to adjust the deck level. When adjusted correctly, tighten the rear jam nuts (B) to lock hitch rod in place.

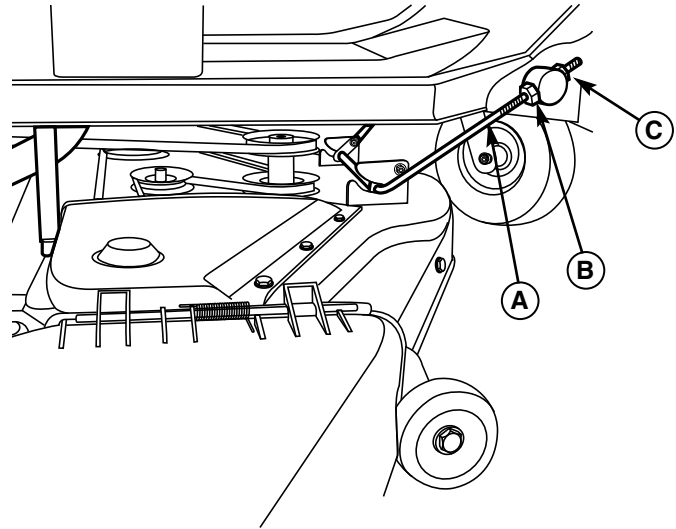

Figure 39. Front-to-Back Leveling

- A. Hitch Rod
- B. Rear Jam Nut
- C. Front Jam Nut

MOWER BELT REPLACEMENT

⚠ WARNING

Before inspecting or servicing the mower, turn the mower blades OFF, turn the ignition switch OFF, and allow all moving parts to stop. Remove ignition key, then disconnect the spark plug wire and fasten it away from the spark plug.

Mower Drive Belt Replacement

1. Park the rider on a level surface. Disengage the PTO, turn off the engine and set the ground speed control levers to PARK. Remove the key.
2. Use the idler pulley arm (C, Figure 40) to release belt tension and remove the mower drive belt (A) from the PTO pulley (E).
3. Remove the belt from the remaining deck pulleys. Note: It is not necessary to remove the mower deck.
4. Install the new belt (A) as shown in Figure 40.

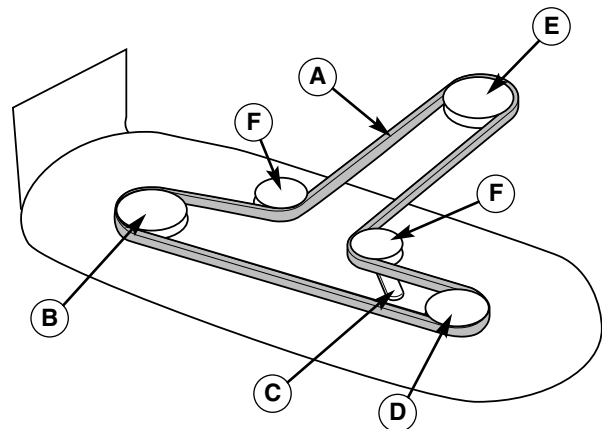

Figure 40. PTO Belt Routing

- A. Mower Drive Belt
- B. Right Arbor Pulley
- C. Idler Pulley Arm
- D. Left Arbor Pulley
- E. Engine PTO Pulley
- F. Backside Idler Pulley

STORAGE

STORAGE

Before Storage

Before you store your unit for the off-season, read the Maintenance and Storage instructions in the Safety Rules section, then perform the following steps:

- Turn the mower blades OFF, set the ground speed control levers to START / PARK, & remove the key from the ignition switch.
- Check all fluid levels. Check all maintenance items.
- Battery life will be increased if it is removed, put in a cool, dry place and fully charged about once a month. If the battery is left in the unit, disconnect the negative cable.

It is important to prevent gum deposits from forming in the essential fuel system parts such as the carburetor, fuel filter, fuel line, and fuel tank during storage. Also, alcohol blended fuels (called gasohol or using ethanol or methanol) can attract moisture which leads to the separation and formation of acids during storage. Acidic gas can damage the fuel system of an engine while in storage.

To avoid engine problems use fuel stabilizer, especially before storage of 30 days or longer.

After Storage

Before starting the unit after it has been stored:

- Check all fluid levels. Check all maintenance items.
- Fill with FRESH fuel.
- After starting, allow the engine to warm before operating.

WARNING

Never store the unit (with fuel) in an enclosed, poorly ventilated structure. Fuel vapors can travel to an ignition source (such as a furnace, water heater, etc.) and cause an explosion.

Fuel vapor is also toxic to humans and animals.

TROUBLESHOOTING

While normal care and regular maintenance will extend the life of your equipment, prolonged or constant use may eventually require that service be performed to allow it to continue operating properly. The troubleshooting guide below lists the most common problems, their causes and remedies.

If you prefer, all of these procedures can be performed by your local authorized dealer.

WARNING

To avoid serious injury, perform maintenance on the rider or mower only when the engine is stopped and the ground speed levers are set to PARK.

Always remove the ignition key, disconnect the spark plug wire and fasten it away from the plug before beginning the maintenance, to prevent accidental starting of the engine.

Troubleshooting the Rider

PROBLEM	CAUSE	REMEDY
Engine will not turnover.	Ignition switch not turned fully to START position.	Turn ignition switch fully to START position.
	Ground speed levers not set to START/PARK.	Set to START/PARK.
	Mower blade switch in ON position.	Place in OFF position.
	Battery terminals require cleaning.	Clean the battery terminals
	Battery discharged or dead.	Recharge or replace.
	Wiring loose or broken; connector separated.	Visually check wiring & replace broken or frayed wires. Tighten loose connections.
	Safety interlock switch faulty.	Replace. Contact your local authorized dealer.
Engine will turnover but will not start.	Solenoid or starter motor faulty.	Replace. Contact your local authorized dealer.
	Engine is cold; choke not in CLOSED position.	Move choke to CLOSED position.
	Engine is warm; choke not in OPEN position.	Move choke to OPEN position.
	Engine flooded.	Set choke to OPEN position when cranking engine.
	Out of fuel.	Allow engine to cool, then refill the fuel tank.
	Fuel is old or stale, or water in fuel.	Drain fuel & replace with fresh fuel. Contact your local authorized dealer.
	Spark plug(s) faulty, fouled or incorrectly gapped.	Clean and gap or replace.
Engine starts hard or runs poorly.	Safety interlock switch faulty.	Replace. Contact your local authorized dealer.
	Air filter plugged	Service pre-cleaner and/or replace air filter element.
	Choke not set to CLOSED position when cranking the engine, OR choke not set to OPEN after engine starts.	Set choke to CLOSED when cranking. Set choke to OPEN when engine is running. A warm engine may not require choking.
Engine knocks.	Spark plug faulty, fouled, or incorrectly gapped.	Clean and gap or replace.
	Low oil level.	Check/add oil as required.
	Using wrong grade oil.	See "Change Engine Oil" in the Maintenance Section.
Excessive oil consumption.	Engine running too hot.	Clean engine cooling fins, blower screen and air cleaner.
	Using wrong weight oil.	See "Change Engine Oil" in the Maintenance Section.
	Too much oil in crankcase.	Drain excess oil.
Engine exhaust is black.	Dirty air filter or pre-cleaner, or both.	Service or replace as required. See Maintenance Section.
	Choke set to CLOSED when engine is running.	Set choke to OPEN as soon as engine starts.

Engine runs, but rider will not drive.	Transmission release levers in PUSH positions.	Move levers to DRIVE positions.
	Drive belt slips.	Clean or replace belt as necessary.
	Belt is broken.	Replace drive belt. Contact your local authorized dealer.
	Parking brake is not fully released.	Contact your local authorized dealer.
Parking brake will not hold.	Parking brake is incorrectly adjusted.	See Service & Adjustments Section.
Rider steers or handles poorly.	Improper tire inflation.	See Maintenance Section.
	Steering linkage is loose.	Check and tighten any loose connections.
Rider tracks to one side.	Ground speed adjustment knobs not adjusted.	See SPEED BALANCING ADJUSTMENT in Service & Adjustments section.

Troubleshooting the Mower		
PROBLEM	CAUSE	REMEDY
Mower cutting height does not adjust.	Cutting height motor screw dirty or requires lube.	Thoroughly clean and lubricate cutting height motor screw.
	Cutting height linkage disconnected.	Check that mower linkage is connected.
Mower cut is uneven.	Rider tires not inflated equally or properly.	See Maintenance Section.
	Mower not leveled properly.	See "Mower Leveling" in Service & Adjustments.
Mower cut is rough looking.	Engine speed too slow.	Always set engine speed to FAST when mowing.
	Ground speed too fast.	Decrease ground speed.
	Blades are dull.	Sharpen or replace blades. See Maintenance Section.
	Mower drive belt slipping because it is oily or worn.	Clean or replace belt as necessary.
	Blades not properly fastened to arbors.	See "Check/Replace Mower Blades" in Maintenance Section.
Engine stalls easily with mower engaged.	Engine speed too slow.	Always set engine speed to FAST when mowing.
	Ground speed too fast.	Decrease Ground Speed.
	Cutting height set too low.	Cut tall grass at maximum cutting height during first pass.
	Underside of mower deck dirty.	Remove mower deck and clean underside.
	Discharge chute jamming with cut grass.	Cut grass with discharge pointing toward previously cut area.
Excessive mower vibration.	Blade mounting nuts are loose.	Tighten to 80-90 ft. lbs. (108-122 N.m.).
	Mower blades, arbors, or pulleys are bent.	Check and replace as necessary.
	Mower blades are out of balance.	Replace or balance blades. See Maintenance Section.
	Belt installed incorrectly.	Reinstall correctly.
Mower drive belt slips or fails to drive.	Idle pulley spring broken or not properly attached.	Repair or replace as needed.
	Mower drive belt broken.	Replace drive belt.
	PTO clutch out of adjustment.	Adjust PTO clutch. See Maintenance Section.

SPECIFICATIONS

NOTE: Specifications are correct at time of printing and are subject to change without notice.

ENGINE:

Make	Briggs & Stratton
Model	Intek
Horsepower	20 @ 3600 rpm
Displacement	30.59 Cu. in (501cc)
Electrical System	12 Volt, 9 amp. Alternator, Battery: 230 CCA
Oil Capacity	44 Oz. (1.3 L) w/o filter; 48 Oz. (1.42 L) w/ filter

TRANSMISSION:

Type	Hydro-Gear EZT ZC-AHBB-2A7B-1DPX
Hydraulic Fluid	20w 50 Premium Engine Oil
Continuous Torque Output	115 ft. lbs.
Maximum Weight per Axle	340 lbs

CHASSIS:

Fuel Tank Cap.	Capacity: 3.25 Gallons (12,3 L)
Rear Wheels	Tire Size: 18 x 8.5 -8 Inflation Pressure: 10-12 psi (.69-.83 bar)
Front Wheels	Tire Size: 11 x 4-5 Inflation Press.: 18-20 psi (1,24-1,30 bar)

The gross power rating for individual gas engine models is labeled in accordance with SAE (Society of Automotive Engineers) code J1940 (Small Engine Power & Torque Rating Procedure), and rating performance has been obtained and corrected in accordance with SAE J1995 (Revision 2002-05). Torque values are derived at 3060 RPM; horsepower values are derived at 3600 RPM. Actual gross engine power will be lower and is affected by, among other things, ambient operating conditions and engine-to-engine variability. Given both the wide array of products on which engines are placed and the variety of environmental issues applicable to operating the equipment, the gas engine will not develop the rated gross power when used in a given piece of power equipment (actual "on-site" or net horsepower). This difference is due to a variety of factors including, but not limited to, accessories (air cleaner, exhaust, charging, cooling, carburetor, fuel pump, etc.), application limitations, ambient operating conditions (temperature, humidity, altitude), and engine-to-engine variability. Due to manufacturing and capacity limitations, Briggs & Stratton may substitute an engine of higher rated power for this Series engine.

SERVICE ITEMS

Replacement Parts

Replacement parts are available from your authorized dealer. Always use genuine Simplicity or Snapper Service Parts.

Maintenance Items

Many convenient and helpful service and maintenance items are available from you authorized dealer. Some of these items include:

Engine Oil	Tire Sealant
Touch-Up Paint	Degreaser/Degreaser
Grease Gun Kit	Gas Stabilizer
8 oz. Grease Tube	

Technical Manuals

Additional copies of this manual are available, as well as fully illustrated parts lists. These manuals show all of the product's components in exploded views (3D illustrations which show the relationship of parts and how they go together) as well as part numbers and quantities used. Important assembly notes and torque values are also included.

For applicable manuals currently available for your model, contact our Customer Publications Department at 877-249-6647. Have the information listed in the box at left available when phoning in your request. Technical manuals can be downloaded from

www.simplicitymfg.com

www.snapper.com

Model:	_____
Mfg. No.:	_____
Your Name:	_____
Address:	_____
City, State, Zip:	_____
Visa/Mastercard No.:	_____
Card Expiration Date:	_____

NOTES



Lawn Care & Mowing Information

HOW AND WHEN TO WATER, FERTILIZE & AERATE

Most lawns are watered too often, but with too little water. However too much water can allow development of diseases with your lawn. It is best to water the lawn only when necessary, and then to water it slowly, evenly, and deeply—imitating a slow, soaking rain.

WHEN TO WATER YOUR LAWN

When the lawn begins to wilt, the grass's color dulls, or footprints stay compressed for more than a few seconds, the lawn is beginning to dry out, and needs additional moisture. The best time to water is early morning to allow the water to soak deeply into the lawn and reduce the amount that evaporates in the hot afternoon sun.

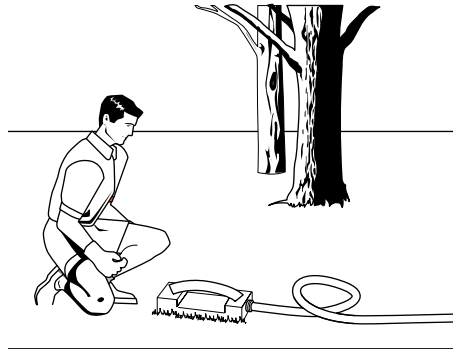

HOW TO WATER YOUR LAWN

The best method of watering a lawn is to imitate a slow, soaking rain, applying about 1 inch of water.

HOW TO FERTILIZE YOUR LAWN

Fertilizing with a slow-release fertilizer provides missing nutrients which help create slow, even growth. Remember that over-fertilizing can cause harm, and that most fertilizing should be applied in the spring so that it will release into the lawn through the summer.

AERATING YOUR LAWN

Consider aerating your lawn in spring. Using an aerator to remove cores of soil from the lawn increases the speed of clipping decomposition and encourages deeper root growth by opening up the soil and permitting greater movement of water, fertilizer and air.

HOW HIGH TO MOW THE GRASS

Cutting the grass too short causes weak, thin grass plants, which are easily damaged by dry periods and pests.

Letting grass grow a bit longer—especially when it is hot and dry—reduces heat build-up, preserves needed moisture and protects the grass from heat damage and other problems.

Cutting off too much at one time shocks the plant's growth system and weakens the grass plants. **A good rule of thumb is the 1/3 rule: to cut no more than one third of the grass height, and never more than 1 inch at a time.**

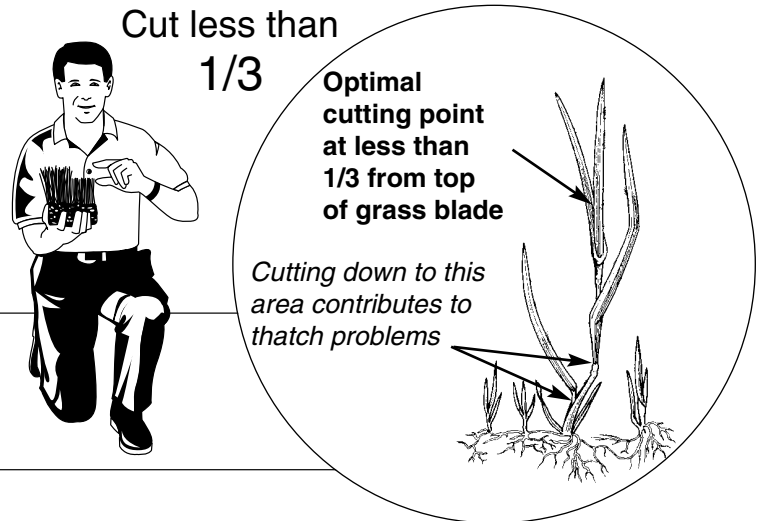

Cut less than $\frac{1}{3}$

Optimal cutting point at less than $\frac{1}{3}$ from top of grass blade

Cutting down to this area contributes to thatch problems

Cut Here On First Pass

Cut Here On Second Pass



Tall Grass Requires Incremental Cutting

For extremely tall grass, set the cutting height at maximum for the first pass, and then reset it to the desired height and mow a second or third time.

Don't cover the grass surface with a heavy layer of clippings.

Lawn Care & Mowing Information

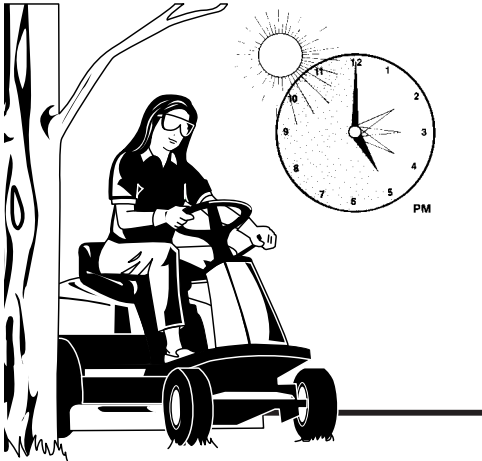

WHEN AND HOW OFTEN TO MOW

The time of day and condition of the grass greatly affect the results you'll get when mowing. For the best results, follow these guidelines:

- Mow when the grass is between 3"-4" (7,5-10 cm) high.
- Mow with sharp blades. Short clippings of grass one inch or shorter decompose more quickly than longer blades. Sharp mower blades cut grass cleanly and efficiently, preventing frayed edges which harm the grass.
- Mow at time of day when the grass is cool and dry. Late afternoon or early evening often provide these ideal mowing conditions.
- Avoid mowing after rain or even heavy dew, and never mulch when the grass is wet (moist grass does not mulch well, and clumps beneath the mower deck).

Note: Always operate the engine at full throttle when mowing.

PROPER MOWING SPEED

ENGINE SPEED & GROUND SPEED

Always operate the engine at full throttle when mowing. If you hear the engine slowing down, you are mowing too fast—maintaining a slower ground speed will improve the cutting efficiency of the blades and prevents many common cutting problems.

Select an appropriate ground speed for the thickness and height of the grass you are cutting (3rd gear or slower for manual gear models, or mid-range or slower for hydro models). If you hear the engine slowing down you are mowing too fast, use a slower ground speed.

HOW MUCH GRASS TO CUT OFF

Mow when the grass is 3"-4" inches (7,5-10cm) long. Do not cut off more than 1" (2.5cm) of grass in a single pass.





MANUFACTURING, INC.
500 N Spring Street / PO Box 997
Port Washington, WI 53074-0997

www.SimplicityMfg.com



PRODUCTS, INC.
535 Macon Street
McDonough, GA 30253

www.Snapper.com

Briggs & Stratton Yard Power Products Group
Copyright © 2007 Briggs & Stratton Corporation
Milwaukee, WI USA. All Rights Reserved

