

SB100F product information sheet

Product Specifications

Fits most: 23" to 37" flat panels

Supports up to: 100 lbs (45.4 kg)

Mounting profile: .75" (19mm)

Mounting: Double-stud

Universal & VESA compliant: 100x200,
200x200, 200x400, 300x400

Color: Black

Product Benefits

- .75" (19mm) low profile design
- Includes universal rails and spacers for greater panel compatibility
- Steel construction for durability and strength
- Sliding lateral on-wall adjustment
- Single wall plate allows for easy installation
- Small footprint provides ample room for power and A/V cutouts behind panel
- Lift n' Lock™ for quick installation
- Locking system for added safety
- Anti-theft security feature
- Includes end caps for a clean side view
- Includes complete Grade 5 hardware kit



With a single wall plate, installing the SB100F flat panel mount is quick and easy.



Series



SB100F



SB150F



SB200F

Dedicated to being a one-stop-shop for professional products, OmniMount remains on the cutting edge of product innovation. That's why we're the natural choice for any professional, industrial, or commercial application. OmniMount Slimback mounts are not only extremely low profile, they are the simplest install of any mount on the market today. The SB100F offers your customers a perfect companion to medium, ultra thin profile flat panels.



SB100F technical data sheet



Dedicated to being a one-stop-shop for professional products, OmniMount remains on the cutting edge of product innovation. That's why we're the natural choice for any professional, industrial, or commercial application. OmniMount Slimback mounts are not only extremely low profile, they are the simplest install of any mount on the market today. The SB100F offers your customers a perfect companion to medium, ultra thin profile flat panels.



Product Specifications

Fits most: 23" to 37" flat panels

Supports up to: 100 lbs (45.4 kg)

Mounting profile: .75" (19mm)

Mounting: Double-stud

Universal & VESA compliant: 100x200, 200x200, 200x400, 300x400

Color: Black

Product Benefits

- .75" (19mm) low profile design
- Includes universal rails and spacers for greater panel compatibility
- Steel construction for durability and strength
- Sliding lateral on-wall adjustment
- Single wall plate allows for easy installation
- Small footprint provides ample room for power and A/V cutouts behind panel
- Lift n' Lock™ for quick installation
- Locking system for added safety
- Anti-theft security feature
- Includes end caps for a clean side view
- Includes complete Grade 5 hardware kit

	Stock Code	Packaging UPC	MC UPC
Americas	1004404-1	728901023262	728901716713
International	NA	NA	NA

	Dimensions WxDxH inches (mm)	Wt lbs (kg)
Product Box	27.9 x 4.7 x 1.8 (708x118x45)	5.1 (2.5)
Master Carton	29.3 x 10.4 x 4.7 (745x265x120)	23.2 (10.5)

Box Contents	Qty
Wall plate	1
Universal rail	2
Locking bar	1
Complete mount installation hardware kit	1
Complete mount attachment hardware kit	1
Instruction manual	1
Flat panel compatibility chart	1

SB100F line drawing

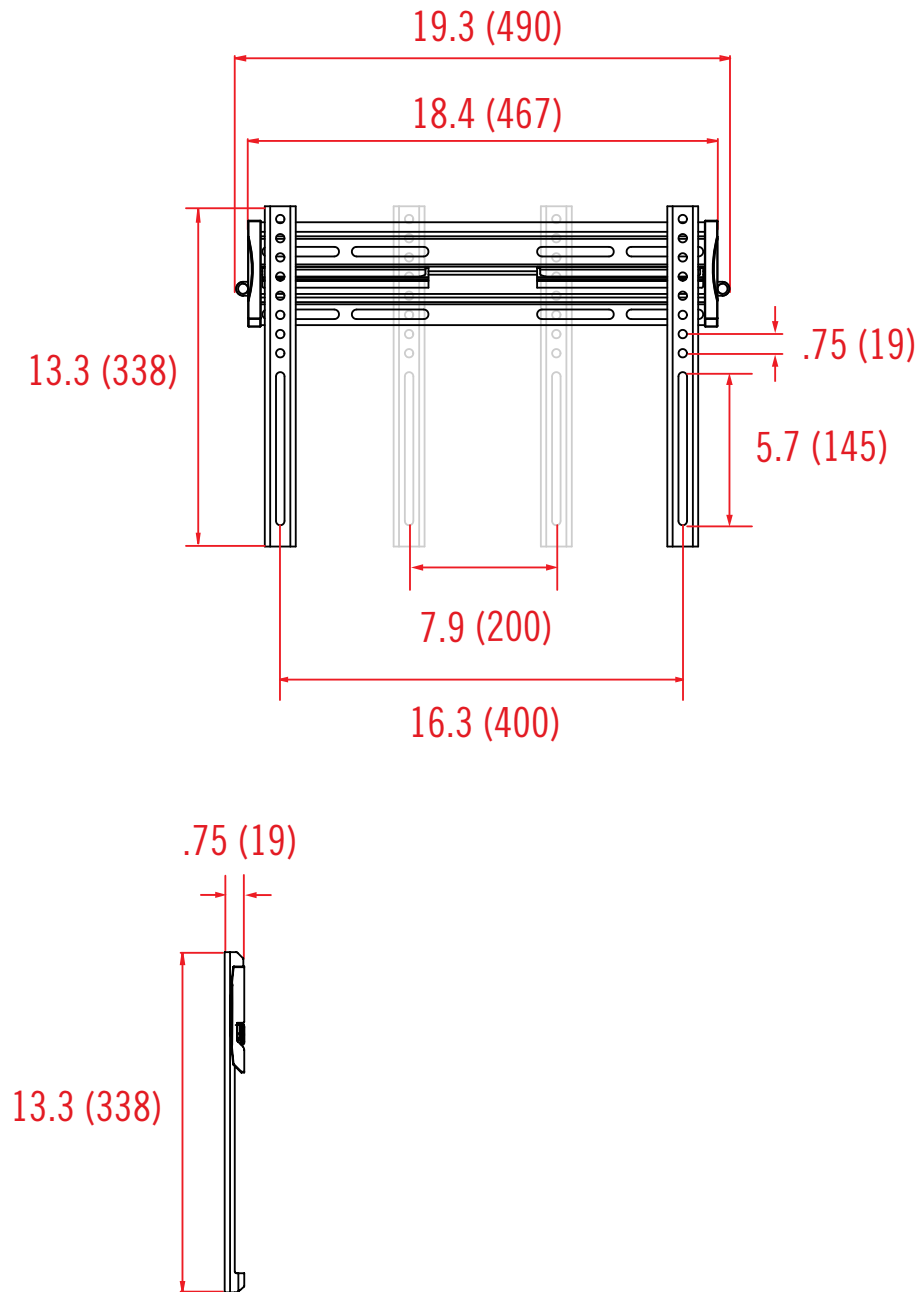

inches (mm)

Architects Specifications

The flat panel wall mount shall be an OmniMount model SB100F and shall be located where indicated on the plans. It shall be constructed of sheet metal. Assembly and installation shall be done according to instructions provided by the manufacturer.