

OWNERS MANUAL

Ariens

8HP

Lawn Tractor

SERIAL NUMBER

MODEL 929001 8 HP GEAR
SERIAL NUMBER 000101 AND UP
MODEL 929002 8 HP HYDRO
SERIAL NUMBER 000101 AND UP
MODEL 829002 36" RM
SERIAL NUMBER 000101 AND UP

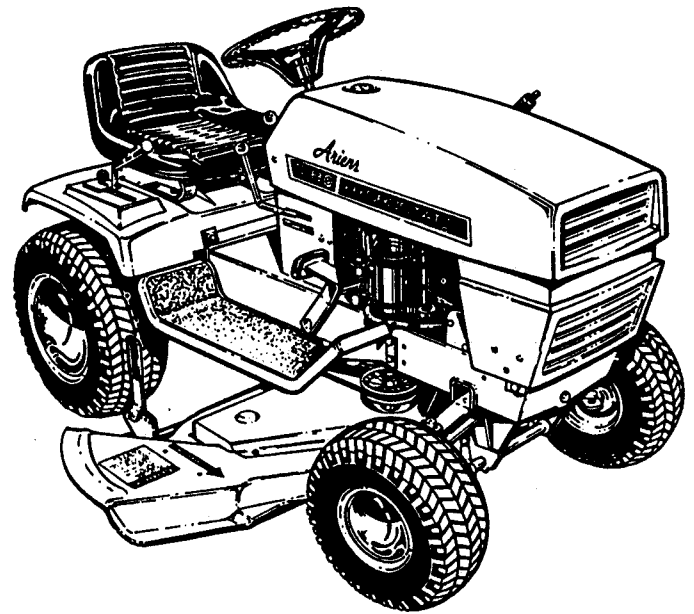

Part No. 29004A

ARIENS COMPANY



BRILLION, WIS. 54110

HYDROSTATIC



S-8

78402 L. H. SIDE STRIPE

S-8



HYDROSTATIC

78403 R. H. SIDE STRIPE

LOWER ← ATTACHMENT → RAISE

78340

Ariens

78244 (1 EACH SIDE)

WARNING

Rotating parts under entire housing. Keep hands and feet away.

78269 (ON LEFT HAND SIDE OF MOWER PAN)

DISENGAGE ← → ENGAGE ATTACHMENT DRIVE

78338

WIDTH OF CUT

78270

+ CAUTION

1. Keep all shields in place.
2. Before servicing machine: shut off engine, make sure mechanism has stopped, disconnect engine spark plug wire.
3. Do not stand near machine while it is in motion.
4. Keep hands, feet and clothing away from power-driven parts.
5. Check for and repair any damage caused by striking solid objects.

78271

WARNING

ROTATING FAN

78280

(UNDER REAR DECK)

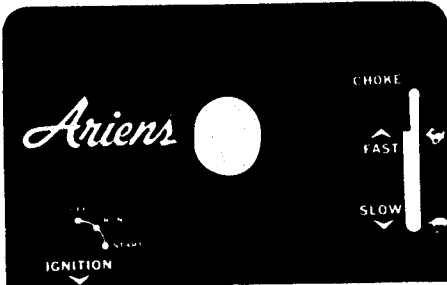

78265

STARTING PROCEDURE

1. Place control lever in Park Start
2. Disengage attachment drive
3. Advance throttle to choke position
4. Turn key switch fully to right
5. Release key and pull throttle down when engine starts

EMERGENCY BRAKING

Depress pedal fully

To move tractor with engine stopped, rotate lever under rear deck

+ CAUTION

Before dismounting, place control lever in Park Start, depress pedal fully and engage brake lock, disengage attachment drive, shut off engine and remove key. Maintain proper transmission oil level to prevent transmission damage and loss of backing control. Keep all shields in place.

78274



78226

COMPLIANCE WITH CANADIAN RADIO INTERFERENCE REGULATIONS CERTIFIED
REPLACE SPARK PLUG WITH RESISTOR SPARK PLUG ONLY!

CERTIFIE CONFORME AU REGLEMENT CANADIEN SUR LE BROUILLAGE RADIOELECTRIQUE
REPLACER LA ROUGIE PAR UNE ROUGIE A RESISTANCE SEULEMENT!

78400 (UNDER FRONT DECK NEXT TO SPARK PLUG)

INSTRUCTIONS FOR SAFE OPERATION

1. Know the controls and how to stop quickly. READ THE OWNER'S MANUAL.
2. Do not allow children to operate the vehicle. Do not allow adults to operate it without proper instruction.
3. Do not carry passengers. Keep children and pets a safe distance away.
4. Clear the work area of objects which might be picked up and thrown.
5. Disengage all attachment clutches and shift into park before attempting to start the engine.
6. Disengage power to attachment, stop the engine and place shift lever to "Park-Start" position before leaving the operator's position.
7. Disengage power to attachment and stop the engine before making any repairs or adjustments.
8. Disengage power to attachment when transporting or not in use.
9. Take all possible precautions when leaving the vehicle unattended, such as disengaging the power take-off, lowering the attachment, shifting into park, setting the parking brake, stopping the engine, and removing the key.
10. Do not stop or start suddenly when going uphill or downhill. Mow up and down the face of steep slopes; never across the face.
11. Reduce speed on slopes and in sharp turns to prevent tipping or loss of control. Exercise extreme caution when changing direction on slopes.
12. Stay alert for holes in the terrain and other hidden hazards.
13. Use care when pulling loads or using heavy equipment.
 - a. Use only approved drawbar hitch points.
 - b. Limit loads to those you can safely control.
 - c. Do not turn sharply. Use care when backing.
 - d. Use counterweight(s) or wheel weights when suggested in the owner's manual.
14. Watch out for traffic when crossing or near roadways.

78405 L. H. SIDE STRIPE

78404 R. H. SIDE STRIPE

LOWER ← ATTACHMENT → RAISE

78340

Ariens

78244 (1 EACH SIDE)

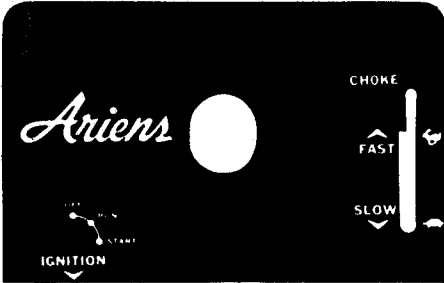

78265

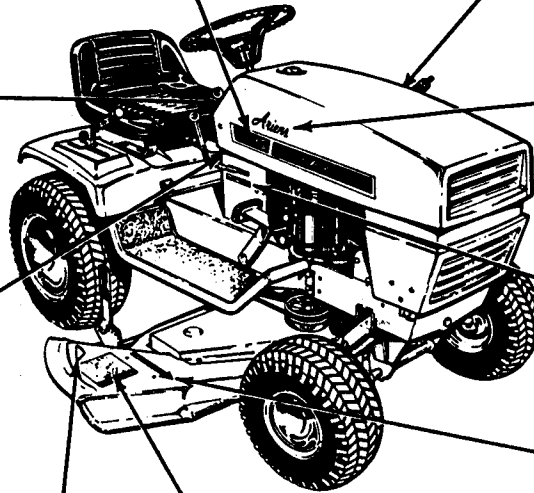

DISENGAGE ← ATTACHMENT DRIVE → ENGAGE

78338

← WIDTH OF CUT

78270

STARTING PROCEDURE

- 1 Place shift lever in Neutral
- 2 Disengage attachment drive
- 3 Advance throttle to choke position
- 4 Turn key switch fully to right
- 5 Release key and pull throttle down when engine starts

EMERGENCY BRAKING

Depress pedal fully

To move tractor with engine stopped, place shift lever in neutral, release brake

+ CAUTION

Before dismounting, depress pedal fully and engage Brake - Lock, disengage attachment drive, shut off engine and remove key

Keep all shields in place

78276



78226

COMPLIANCE WITH CANADIAN RADIO INTERFERENCE REGULATIONS CERTIFIED

REPLACE SPARK PLUG WITH RESISTOR SPARK PLUG ONLY !

CERTIFIE CONFORME AU REGLEMENT CANADIEN SUR LE BROUILLAGE RADIOELECTRIQUE

REPLACER LA ROUGIE PAR UNE ROUGIE A RESISTANCE SEULEMENT !

78400 (UNDER FRONT DECK NEXT TO SPARK PLUG)

+ CAUTION

1. Keep all shields in place.
2. Before servicing machine: shut off engine, make sure mechanism has stopped, disconnect engine spark plug wire.
3. Do not stand near machine while it is in motion.
4. Keep hands, feet and clothing away from power-driven parts.
5. Check for and repair any damage caused by striking solid objects.

78271

! WARNING

Rotating parts under entire housing. Keep hands and feet away.

78269 (ON LEFT HAND SIDE OF MOWER PAN)

BE AWARE OF SAFETY DECALS

15. When using any attachments, never direct discharge of material toward bystanders nor allow anyone near the vehicle while in operation.

16. Handle gasoline with care—it is highly inflammable.
 a. Use approved gasoline container.
 b. Never remove the cap of the fuel or add gasoline to a running or hot engine, or fill the fuel tank indoors. Wipe up spilled gasoline.
 c. Open doors if the engine is run in the garage—exhaust fumes are dangerous. Do not run the engine indoors.

17. Keep the vehicle and attachments in good operating condition, and keep safety devices in place.

18. Keep all nuts, bolts, and screws tight to be sure the equipment is in safe working condition.

19. Never store the equipment with gasoline in the tank inside a building where fumes may reach an open flame or spark. Allow the engine to cool before storing in any enclosure.

20. To reduce fire hazard, keep the engine free of grass, leaves, or excessive grease.

21. The vehicle and attachments should be stopped and inspected for damage after striking a foreign object, and the damage should be repaired before restarting and operating the equipment, see numbers 6 & 7 above.

22. Do not change the engine governor settings or overspeed the engine.

23. When using the vehicle with mower, proceed as follows:
 a. Mow only in daylight or in good artificial light.
 b. Never make a cutting height adjustment while the engine is running if the operator must dismount to do so.
 c. Shut the engine off when removing the grass catcher or unclogging chute.
 d. Check the blade mounting bolts for proper tightness at frequent intervals.

24. Check the grass catcher bags frequently for wear or deterioration. Replace with new bags for safety protection.

CONTROLS

- ① **IMPLEMENT POWER CLUTCH** – Figure 1
The implement power clutch is used to operate the mower or snow thrower. Push the lever forward to engage the clutch and drive the attachment. Pull the lever rearward to disengage the clutch and stop the attachment. The lever must be in the rear (disengaged) position to start the engine. **THIS IS A SAFETY FEATURE.** The engine will not start until the lever has been placed in the disengaged position.

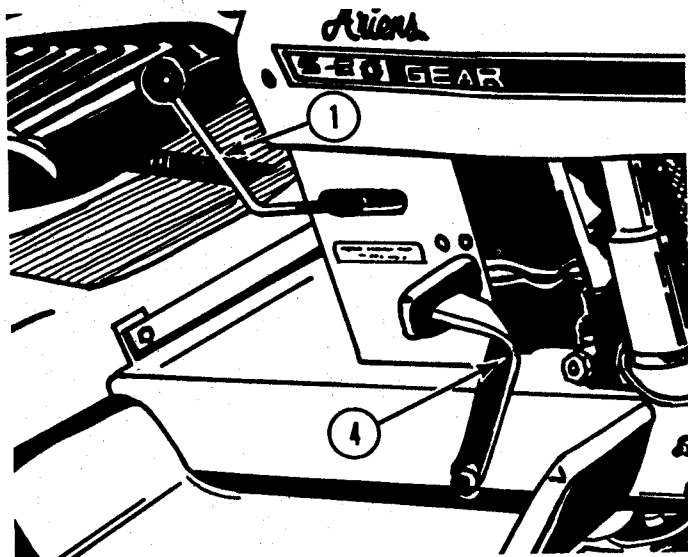

Figure 1

- ② **HYDROSTATIC CONTROL LEVER** (Hydrostatic Models – Figure 2)
This lever regulates both tractor speed and direction. Gradually move the lever forward from the "park-start" (neutral) position to increase forward travel speed. Move the lever rearward to the "R" position to back the tractor and regulate reverse speed.

NOTE: The lines and numbers next to the forward slot do not indicate a given speed. They serve as guide lines only.

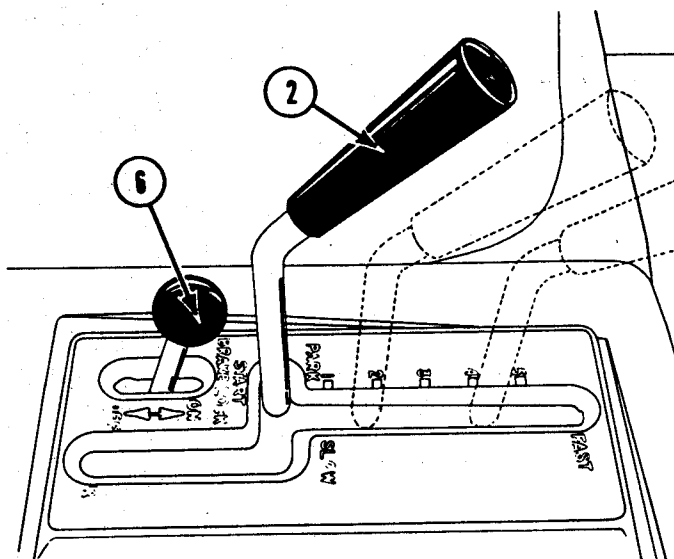

Figure 2

THE CONTROL LEVER MUST BE IN THE "PARK-START" POSITION TO START THE ENGINE.

- ③ **GEAR SHIFT LEVER** – (Gear Shift Models) – Figure 3.
The gear shift lever is used to select any of three forward gears or one reverse gear. The markings 1, 2, 3 and R on the control console indicate the locations of the gears. The slowest forward gear is indicated by No. 1, the secondary gear, No. 2 and the fastest gear, No. 3. The "R" indicates reverse.

THE GEAR SHIFT LEVER MUST BE IN THE FORWARD NEUTRAL POSITION AS SHOWN IN FIGURE 3 TO START THE ENGINE.

- ④ **HYDROSTATIC NEUTRALIZER AND BRAKE PEDAL** (Hydrostatic Models) – Figure 1
When this pedal is depressed, the hydrostatic control lever will return to neutral and stop the forward or reverse motion of the tractor. At the same time, the pedal actuates an independent brake which provides an additional means of stopping the tractor.

NOTE: ALWAYS REMOVE HAND FROM HYDROSTATIC CONTROL LEVER BEFORE DEPRESSING THE NEUTRALIZER AND BRAKE PEDAL. THE TWO CONTROLS ARE INTERCONNECTED. OPERATING THEM SIMULTANEOUSLY COULD RESULT IN DAMAGED OR MIS-ADJUSTED LINKAGE.

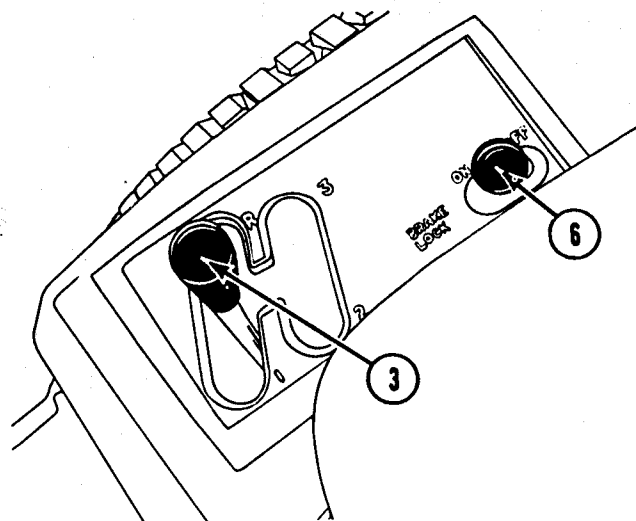

Figure 3

- ⑤ **CLUTCH BRAKE PEDAL** (Gear Shift Models) – Figure 4
The clutch-brake pedal performs two functions:
1. When depressed to the "midway" range the clutch disengages and the transmission can be shifted to any desired gear.
 2. When the clutch-brake pedal is fully depressed, the brake actuates and stops the tractor.

NOTE: Always release the pedal slowly for smooth acceleration. Do not allow foot to rest on pedal except for clutching and braking functions.

6

6 BRAKE LOCK – Figures 2 and 3

A brake lock is provided on both hydrostatic and gear shift models to prevent the tractor from moving when parked or left unattended.

To lock the brake, push the brake lock forward with the foot pedal fully depressed. Then release the foot pedal. Figure 2 shows the brake lock engaged. Figure 3 shows it disengaged.

IMPORTANT: ENGAGE THE BRAKE LOCK BEFORE DISMOUNTING FROM THE TRACTOR OR ANY TIME IT IS LEFT UNATTENDED.

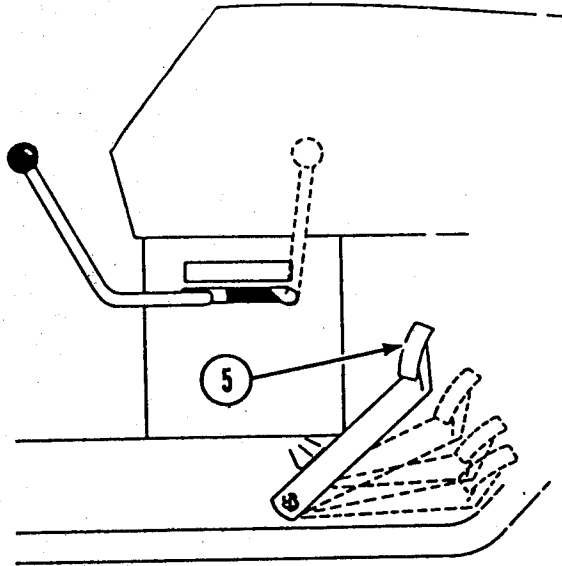

Figure 4

7

7 FREE-WHEELING VALVE (Hydrostatic Models) – Figure 5

The free-wheeling valve is provided so the tractor can be pushed short distances with the engine stopped.

The cam arm, see Figure 5, must be in the forward position as shown at all times except when it becomes necessary to push the tractor.

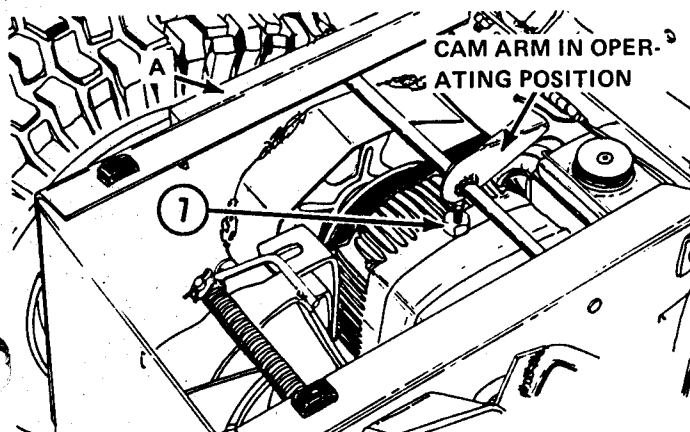

Figure 5

If it becomes necessary to move the tractor with the engine stopped, rotate the cam arm rearward so the valve actuating rod is pushed down into the transmission body. After moving the tractor the cam arm must be returned to the operating position before the tractor will move with the engine running.

IMPORTANT: DO NOT TOW TRACTOR AS INTERNAL TRANSMISSION DAMAGE COULD RESULT.

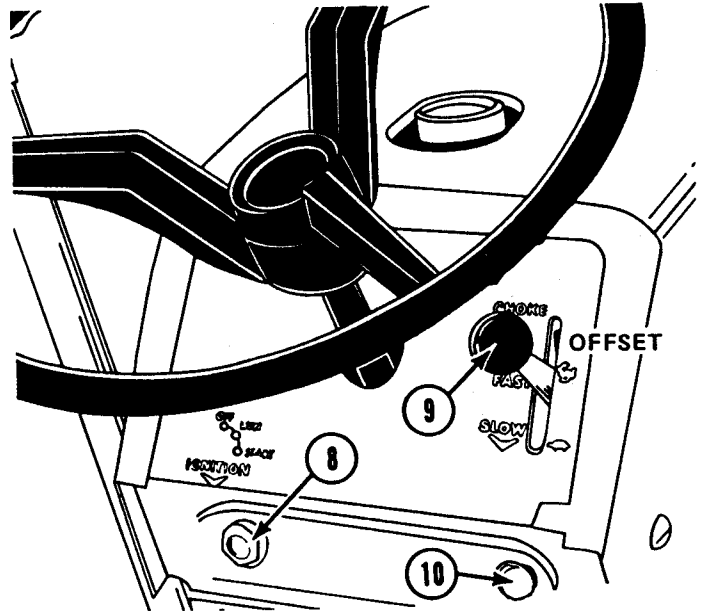

Figure 6

8

8 IGNITION AND STARTER SWITCH – Figure 6

The ignition and starter switch has three positions: "off", "run" and "start". Start the engine by turning the key fully clockwise to start position and then release the key as soon as the engine starts. Stop the engine by turning the key counterclockwise to the "off" position.

9

9 THROTTLE-CHOKE CONTROL LEVER – Figure 6

This control operates both the throttle and choke. When starting a cold engine, raise the lever past the offset and into the "choke" position. After the engine has started, lower the lever to the throttle operating range and allow the engine to warm at 1/2 throttle. Select the appropriate engine speed in the throttle range after the engine has warmed.

NOTE: Unless otherwise specified, the mower or snow thrower should be operated at full throttle. The throttle is not to be used to select desired travel speeds with the hydrostatic models. Operate at full throttle and regulate ground speed with the hydrostatic control lever.

10

10 LIGHT SWITCH (Optional)–(Figure 6)

If the optional light kit is installed, turn lights on by pulling the control knob out. Turn lights off by pushing the knob in;

11

11 ATTACHMENT LIFT LEVER–(Figure 7)

The lift lever shown in figure 7 is used to raise and lower the mower, front blade or snow thrower.

To raise the attachment, pull the lever to the rear until the latch snaps into the notch provided. This will hold the attachment in the raised position.

OPERATION

To lower the attachment, pull the lever to the rear, depress the button to release the latch and allow the lever to move forward. See Figure 7.

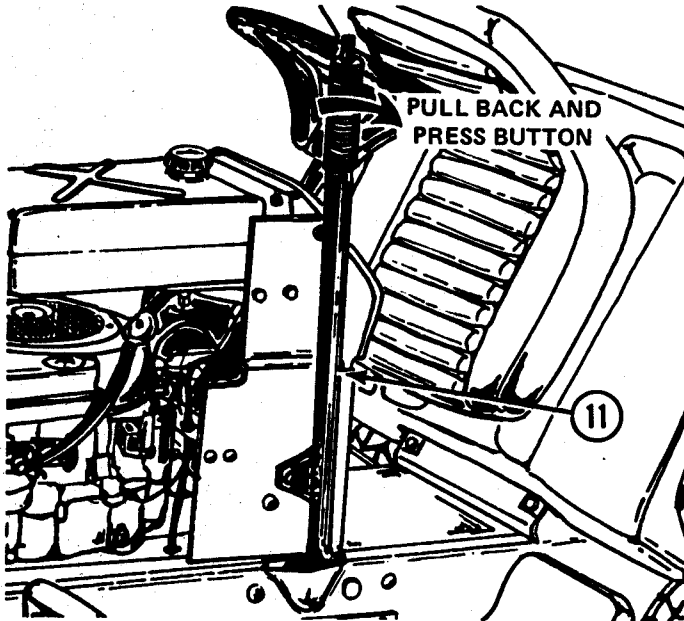

Figure 7

RAISING THE HOOD—(Figure 8)

The engine, battery, electrical components, air cleaner, fuel filter and fuel tank are readily accessible by raising the hood. To raise the hood, grasp each side and raise it upwards and forward to its stop.

RAISING THE REAR DECK — (Figure 8)

The differential, transmission and control linkages are readily accessible by raising the rear deck until the seat rests against the steering wheel.

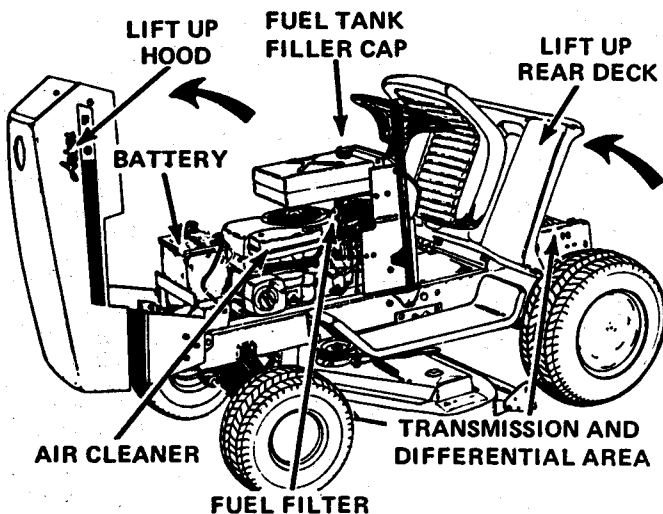

Figure 8

PRE-STARTING INSPECTION

Before starting the engine before each day's operation, the following checks and services should be performed:

1. Check oil in engine crankcase. Add oil as required to maintain proper level. See lubrication section.
2. Check fuel supply. Fill with clean, fresh regular gasoline only. See lubrication section.
3. Check air cleaner and service as required.
4. Check for engine, transmission or differential oil leaks. See your authorized Ariens dealer for repairs.
5. Make visual checks regarding safety precautions, obstructions and maintenance.

STARTING THE ENGINE

Use the following procedure to start the engine:

1. Lock the parking brake (6) by depressing the foot pedal Figure 4, and pushing the brake lock forward to lock the parking brake.
2. HYDROSTATIC MODELS. Place hydrostatic control lever (2) in the "park-start" position as shown in Figure 2.

NOTE: The engine will not start unless the control lever is in the "park-start" position.

3. GEAR SHIFT MODELS. Place gear shift lever (3) in the forward (neutral) position as shown in Figure 3.

NOTE: The engine will not start unless the gear shift lever is in the "forward" neutral position.

4. Place implement power clutch lever (1) Figure 1, in the rear (disengaged) position.

NOTE: This is a safety feature. The engine will not start unless the clutch lever is in the disengaged position.

5. Raise throttle choke control lever (9) Figure 6, past the offset in the slot to the "choke" position.
6. Turn ignition key (8) shown in Figure 6 clockwise all the way. Release key as soon as the engine starts and gradually lower the throttle-choke control lever past the offset until the engine runs at ½ throttle.

NOTE: A WARM ENGINE WILL REQUIRE LESS CHOKING THAN A COLD ENGINE.

If the engine fails to start on the first attempt, turn key to the "off" position, wait a few minutes and try again. Do not operate starter continuously for more than 30 seconds at a time.

Always allow engine to warm up before applying load. Below freezing weather, allow engine to run at a fast idle for a period of at least five minutes before moving the

tractor or starting the attachment. **SERIOUS DAMAGE TO THE ENGINE AND TRANSMISSION COULD RESULT IF THIS PROCEDURE IS NOT FOLLOWED.**

STOPPING THE ENGINE

Always use the following procedure to stop the engine:

1. **HYDROSTATIC DRIVE MODELS.** Move hydrostatic control lever to the "park-start" position.
2. **GEAR SHIFT MODELS.** Move gearshift lever to the "Neutral" position.
3. Disengage the implement power clutch.
4. Engage parking brake by depressing the foot pedal **5** and by moving brake lock **6** forward to "on" position.
5. Lower attachment to the ground.
6. Lower throttle lever and allow the engine to idle for a short period of time. **DO NOT STOP A HOT ENGINE AT HIGH SPEED AS INTERNAL ENGINE DAMAGE COULD RESULT.**
7. Turn ignition key counterclockwise to the "off" position to stop the engine.
8. **BE CAREFUL:** Remove ignition key before dismantling from tractor. This will prevent children and inexperienced operators from starting the tractor.

OPERATING THE HYDROSTATIC DRIVE TRACTOR

1. Start the engine using the procedure explained under "Pre-starting Inspection" and "Starting the Engine."

NOTE: The hydrostatic control lever must be in the "park-start" position and the implement power clutch lever must be disengaged to start the engine.

2. Release parking brake by depressing foot pedal until brake disengages.
3. Select the proper engine speed with the throttle-choke lever. When operating any power-driven attachment, run the engine at full throttle (3400 - 3500 RPM) unless otherwise specified. Use the hydrostatic control lever, **NOT THE THROTTLE**, to select a safe, appropriate travel speed.
4. To start the attachment, engage the implement power clutch with the engine running at ½ throttle. Then increase speed to full throttle.
5. To move the tractor forward and increase the forward travel speed, gradually push the hydrostatic control lever forward from the neutral position as shown in Figure 9. To stop or slow down the tractor, pull the control lever back toward the neutral position.

NOTE: The numbers along the forward slot of the console lever do not indicate given speeds. They are provided as guide lines only.

To move the tractor backward and to increase the reverse travel speed, gradually move the hydrostatic control lever back into the reverse (R) slot from the neutral position. To stop the tractor or slow down the reverse travel speed, gradually move the control lever from the reverse (R) slot toward the neutral position.

IMPORTANT: NEVER OPERATE THE HYDROSTATIC CONTROL LEVER AND THE FOOT PEDAL SIMULTANEOUSLY AS THE LINKAGE COULD BECOME DAMAGED OR MISADJUSTED.

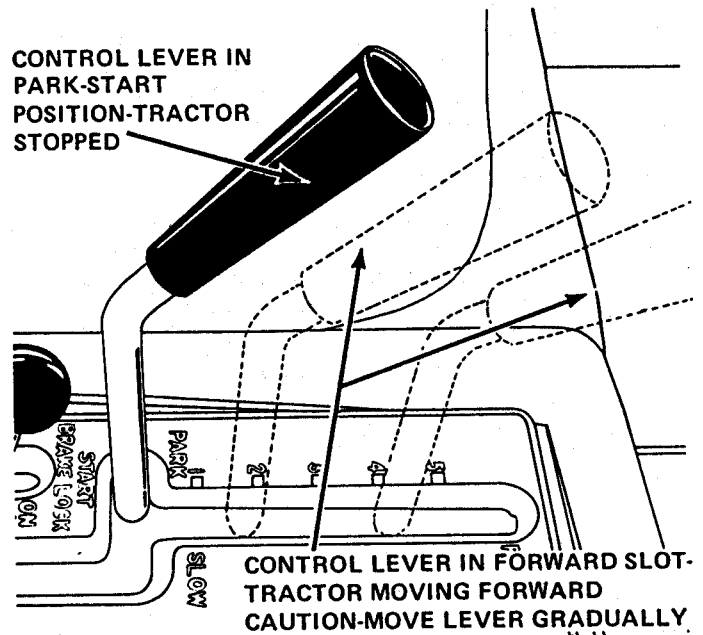

Figure 9



BE CAREFUL: ALWAYS REMOVE THE IGNITION KEY WHEN LEAVING THE TRACTOR TO PREVENT CHILDREN AND INEXPERIENCED OPERATORS FROM STARTING THE ENGINE.

OPERATING THE GEAR SHIFT TRACTOR

1. Start the engine using the procedure explained under "Pre-starting Inspection" and "Starting the Engine."

NOTE: The gear shift lever must be in the forward neutral position and the implement power clutch lever disengaged to start the engine.

2. Release brake lock by depressing the clutch-brake pedal, Figure 10, until the lock disengages.
3. Depress clutch-brake pedal approximately halfway (into the shifting range) as shown in Figure 10. Place gear shift lever into the desired gear and slowly release the pedal to provide smooth acceleration.

IMPORTANT: DO NOT FORCE GEAR SHIFT LEVER IF GEAR DOES NOT ENGAGE. RETURN LEVER TO NEUTRAL, RELEASE PEDAL AND REPEAT THE PROCEDURE. THE CLUTCH-BRAKE PEDAL MUST BE IN THE SHIFTING RANGE TO ENGAGE ANY SELECTED GEAR. DEPRESSING THE PEDAL TOO FAR LOCKS THE TRANSMISSION MAKING IT IMPOSSIBLE TO SHIFT GEARS. DEPRESSING THE PEDAL TOO LITTLE WILL CAUSE GEAR CLASH AND POSSIBLE DAMAGE TO THE TRANSMISSION.

IMPORTANT: TRACTOR MUST BE COMPLETELY STOPPED WHEN SHIFTING GEARS. SERIOUS TRANSMISSION DAMAGE CAN RESULT IF GEARS ARE SHIFTED WITH TRACTOR IN MOTION.

4. Select the desired throttle speed with the throttle-choke control lever. When operating a power-driven attachment, operate the engine at full throttle (3400 - 3500 RPM) unless otherwise specified and control travel speed by selecting an appropriate gear.
5. To start the mower or snow thrower, engage the implement power clutch slowly with the engine running at 1/2 throttle, then increase speed to full throttle.
6. To stop the tractor, depress foot pedal to the braking range, then return it to the shifting range and place gear shift lever in neutral. Fully depress pedal and engage the brake lock when parking or leaving the tractor. (Figure 10)

EMERGENCY STOPPING

Always use caution when mowing--be alert for children, pets or obstacles in path. If necessary to make emergency stop, step firmly on brake pedal. (On hydrostatic model tractor, drive control lever automatically returns to neutral when brake pedal is depressed.)

IMPORTANT: ALWAYS REMOVE IGNITION KEY WHEN LEAVING THE TRACTOR TO PREVENT CHILDREN AND INEXPERIENCED OPERATORS FROM STARTING THE ENGINE.

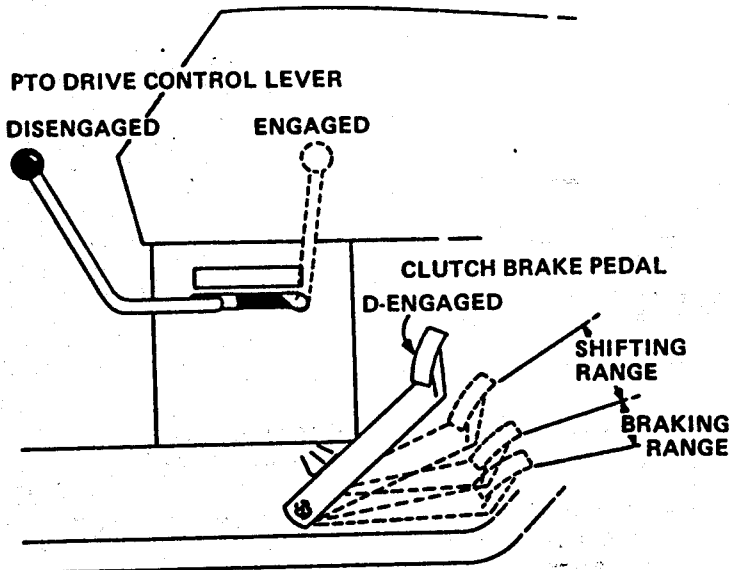

Figure 10

BE CAREFUL

1. BEFORE SERVICING ANY ATTACHMENT:
**DISENGAGE POWER.
 SHUT OFF ENGINE.
 MAKE SURE BLADES OR AUGER HAS STOPPED REVOLVING.
 DISCONNECT ENGINE SPARK PLUG CABLE.**
2. KEEP CHILDREN, BYSTANDERS AND PETS OUT OF THE WORKING AREA.
3. KEEP HANDS, FEET AND CLOTHING AWAY FROM POWER DRIVEN PARTS.
4. KEEP ALL SHIELDS AND GUARDS IN PLACE.



LUBRICATION

Proper lubrication according to a regular schedule is a vital part of maintaining the Model S-8 Garden Tractor. The following lubrication schedule should be followed closely.

Use clean, fresh "regular" grade of automotive gasoline. Do not use premium gasoline. Do not mix oil with gasoline.

FILLING THE TANK - (Figure 11)

The fuel tank filler cap is easily accessible as shown in Figure 11. Before filling the tank, wipe all dust and dirt from around the cap to prevent dirt from falling into the tank. Use an approved gasoline container and keep it clean. Fill tank completely. The tank capacity is 1-3/8 gallons.

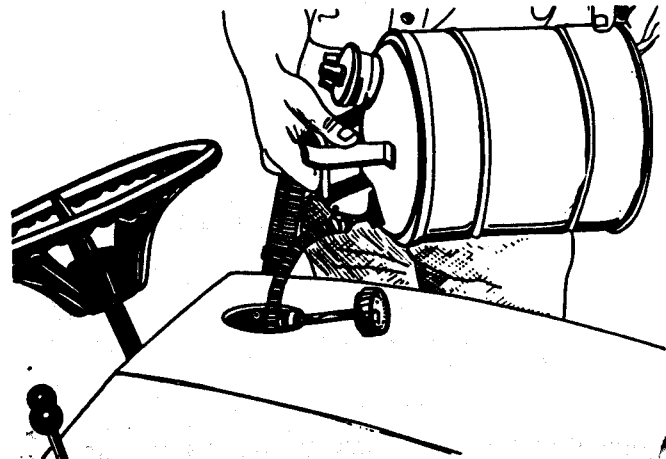

Figure 11



ALWAYS USE CAUTION WHEN HANDLING GASOLINE. NEVER FILL THE FUEL TANK WHEN THE ENGINE IS RUNNING OR WHEN THE ENGINE IS HOT. NEVER SMOKE WHILE FILLING THE TANK. REMOVE THE IGNITION KEY BEFORE FILLING TANK.

ENGINE OIL LEVEL

Check the engine crankcase oil level daily or every five hours of operation. The oil level should be maintained to the "Full" mark on the dipstick, Figure 12. Never allow the oil level to fall below the "Add" mark or serious engine damage could result. **DO NOT OVERFILL.** Oil level must never exceed the "full" mark. Oil capacity is 2 1/4 U.S. pints.

To check the oil, place the tractor on a level surface, stop the engine and wipe all dirt and dust from around the dipstick, Figure 12. Pull dipstick out, wipe off the oil and reinsert by pushing it down tightly (until it snaps into place). Pull dipstick out and observe the oil level. Add sufficient oil of the proper viscosity (see chart) to bring the level up to the "Full" mark.

SERVICE	OIL TYPE
Lawn and Garden Attachments	Ariens SAE 10W-30 MS or equivalent
Snow Removal Equipment	Ariens SAE 5W-20 MS or equivalent

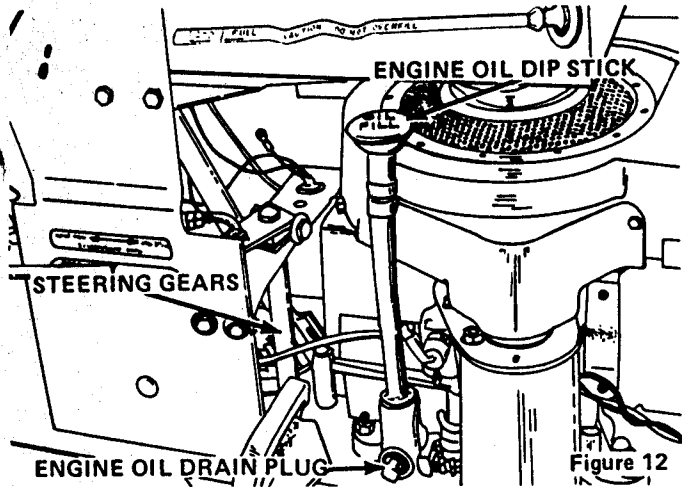

IMPORTANT: ENGINE WILL SMOKE EXCESSIVELY IF DIPSTICK IS NOT PUSHED DOWN UNTIL IT SNAPS INTO PLACE.

CHANGE ENGINE CRANKCASE OIL

When the tractor is new, the oil should be changed after the first five hours of operation. Thereafter under normal operating conditions the oil should be changed every 25 hours of operation. If extremely dusty or dirty conditions prevail, change oil more frequently.

Drain crankcase by removing the oil drain plug, Figure 12, while the engine is warm. Allow the oil to run into a container.

NOTE: With the engine warm, the oil will flow more freely permitting more contaminants to be drained from the crankcase.

Replace drain plug. Remove dipstick and refill crankcase with 2 1/4 U.S. pints of the proper type and viscosity of oil as shown in the chart. Check oil on the dipstick to determine that the level is to the "Full" mark. **DO NOT OVERFILL.**

TRANSMISSION OIL LEVEL (Gear Shift Models)

The transmission oil level should be checked monthly or every 25 hours of operation.

To check the oil level, place tractor on a level surface, raise the rear deck and remove the "check plug" from the rear of the transmission as shown in Figure 13. The level is correct when oil seeps out of the check plug hole. If the level is below the check plug hole, remove the filler plug from the top of the transmission and add Ariens Premium Gear Lube SAE 90 MP until the proper level is reached.

DIFFERENTIAL OIL LEVEL (Hydrostatic Models)

The differential oil level should be checked monthly or every 25 hours of operation.

To check the oil level, place the tractor on a level surface, raise the rear deck and remove the "filler plug" at the rear of the differential, Figure 14. The level is correct when the lubri-

cant reaches the filler plug hole. Add Ariens Premium Gear Lube SAE 90 MP until the proper level is reached.

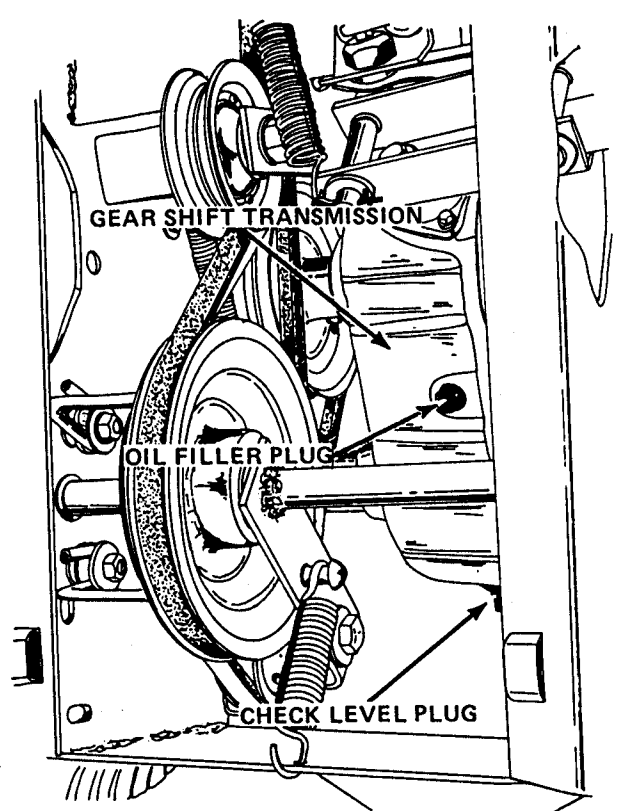

Figure 13

TRANSMISSION OIL LEVEL (Hydrostatic Models)

The hydrostatic transmission oil level should be checked monthly or every 25 hours of operation.

To check the oil level, raise the rear deck and clean all dirt and dust from the oil expansion reservoir area, Figure 15. Remove cap from the reservoir and observe the oil level. The level is correct when the reservoir is 1/2 full at ambient temperature.

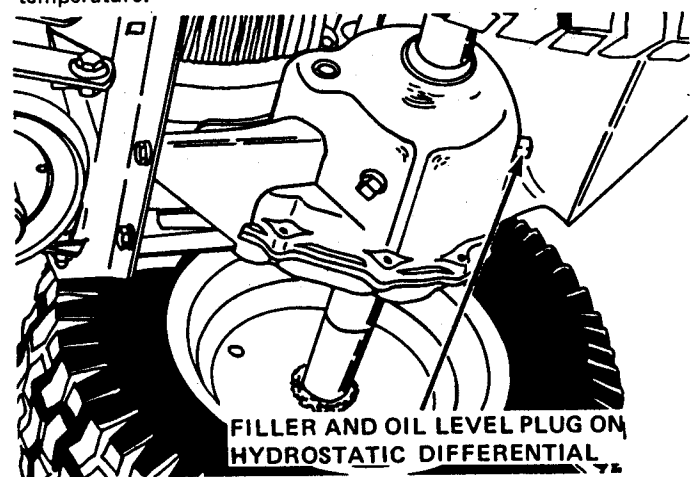

Figure 14

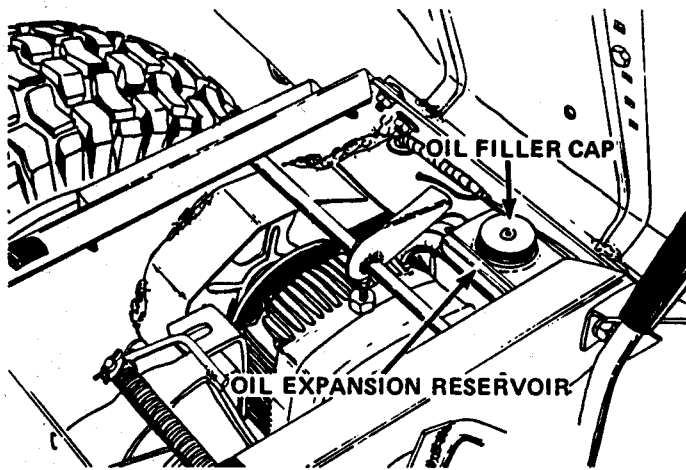

Figure 15

If the reservoir is less than ½ full at ambient temperature, add TYPE "A" transmission FLUID until proper level is obtained.

IMPORTANT: ALWAYS USE NEW, CLEAN, TYPE "A" TRANSMISSION OIL AND BE EXTREMELY CAREFUL NOT TO ALLOW ANY FOREIGN MATTER TO CONTAMINATE THE OIL AS SERIOUS TRANSMISSION DAMAGE COULD RESULT.

DO NOT OVERFILL the reservoir as the oil expands during operation and may leak out around the cap.

IMPORTANT: PROPER OIL LEVEL IS ESSENTIAL FOR FULL BRAKING EFFECT AND PROTECTION AGAINST SEVERE TRANSMISSION DAMAGE.

STEERING GEARS

Apply a light coat of Ariens Moly Lithium grease to the steering gears every 50 hours of operation. See Figure 12.

INTERMEDIATE STEERING SHAFT

Apply oil to the bearing surfaces of the blocks every 50 hours of operation. See Figure 16.

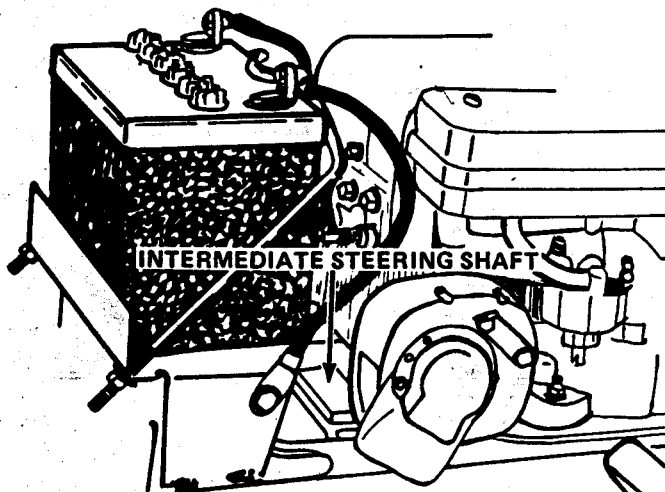

Figure 16

GREASE FITTINGS

Following is a list of the grease fittings with reference numbers that identify each location on the corresponding

pictures. Figures 17 & 18. Each fitting should be wiped before and after lubrication. Grease each fitting every 50 hours of operation with Ariens Moly Lithium grease.

1. Figure 17 — Right and left king pin.
2. Figure 17 — Right and left front wheel.
3. Figure 18 — Hydrostatic control arm pivot (hydrostatic models)

POINTS TO OIL

Periodically oil the lift point pivots, front axle pivot, control linkage pivots and the floating intermediate shaft pin to insure long life and smooth operation of the parts.

There is no lubrication required on the mower.

IMPORTANT: KEEP GREASE AND OIL OFF THE BELT TO PREVENT BELT SLIPPAGE AND DETERIORATION

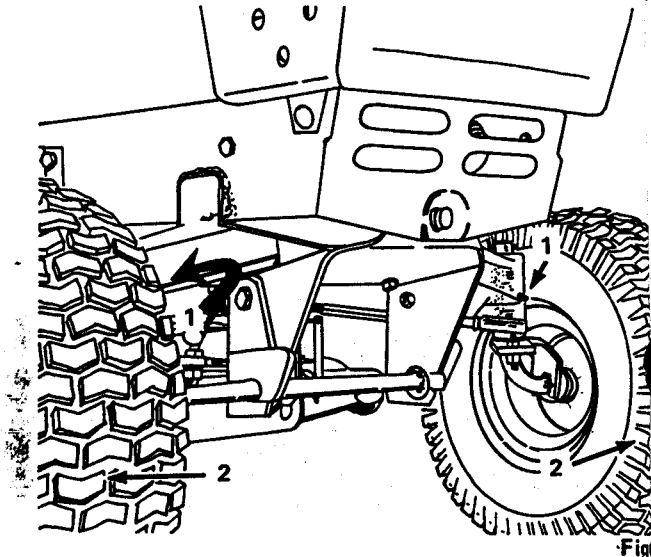

Fig

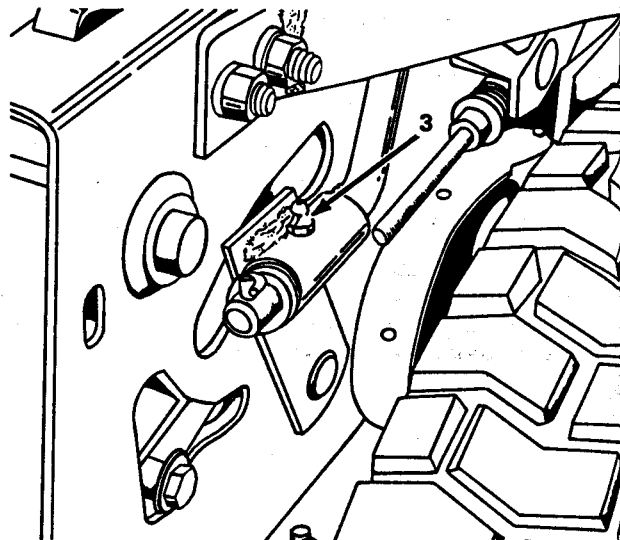

Fig

MAINTENANCE

GENERAL

Ariens dealers will provide any service which may be required to keep the Lawn Tractor operating at peak efficiency. Ariens Company recommends that you contact an Ariens dealer before making any adjustments to this tractor. Refer to the engine instruction manual and engine nameplate for engine maintenance instructions. If repairs or service are required for the engine, see your Ariens dealer or the nearest authorized engine service station.

AIR CLEANER SERVICE

Clean the air cleaner and re-oil the element every 25 hours under normal operating conditions. When operating in extremely dusty conditions, perform this service at more frequent intervals. Use the following procedure to service the air cleaner:

1. Raise the tractor hood. Remove screws A, Figure 19, and lift off complete air cleaner assembly.
2. Remove screen and spacers from the foam element, Figure 19.
3. Wash foam element in kerosene or liquid detergent and water to remove dirt. Wrap foam in cloth and squeeze dry. Let dry overnight.
4. Saturate foam element in clean engine. Squeeze to remove the oil.
5. Re-assemble parts and re-install complete assembly on the carburetor.

NOTE: When re-assembling the parts, make certain the foam element extends over the edge of the air cleaner body. The foam element will form a protective seal.

IMPORTANT: NEVER RUN THE ENGINE WITH THE AIR CLEANER REMOVED!

ENGINE COOLING SYSTEM

The engine is air cooled. Grass particles, chaff and dirt may clog the cooling system, especially when mowing dry grass or operating in extremely dusty conditions. Continued operation with a clogged cooling system may cause severe overheating and possible engine damage.

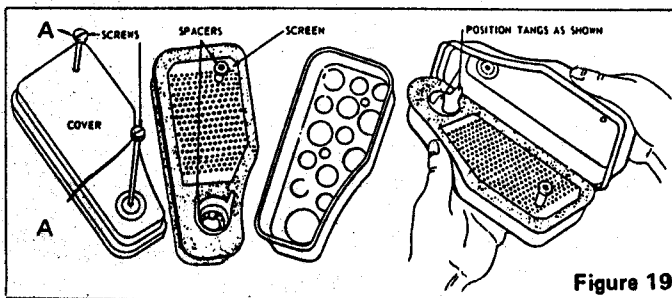

Figure 19

It is essential that the rotating screen, engine cooling fins and the exhaust system be kept free of dirt and debris which could cause the engine to overheat.

To avoid overheating and possible engine damage, periodically remove the shrouding from around the cooling fins, Figure 20, and clean the area shown within the heavy black line of all grass, dirt or chaff accumulation.

TRANSMISSION COOLING SYSTEM

Dirt and grime accumulations on transmission cooling fins can cause overheating. Check and clean the cooling fins every 50 hours of operation or quarterly. In extremely dusty or dirty conditions, clean the cooling fins more frequently.

CAUTION: KEEP WATER AWAY AND OFF RESERVOIR.

Check the hydrostatic cooling fan blades periodically to assure that the blades are not bent or broken and that the fan is in good condition.

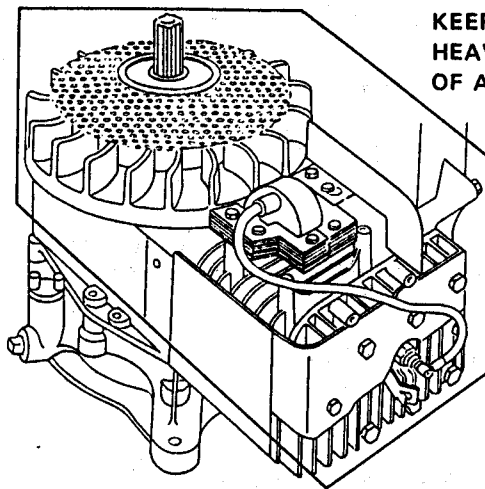

KEEP AREAS WITHIN HEAVY LINES CLEAR OF ALL DEBRIS

Figure 20

BLEEDING THE TRANSMISSION

If for any reason the oil level is ever permitted to fall below the expansion reservoir, air may enter the system causing the transmission to malfunction. If this should occur, use the following procedure to "bleed" (remove air from the transmission):

1. Thoroughly clean all dust, dirt and grime from the free-wheeling valve, the oil filler cap and surrounding areas, Figure 21.
2. Remove nut A, Figure 22 from the left end of the cam assembly shaft and slide the cam assembly to the right until the cam arm is free of the valve actuating rod.
3. Loosen nut B first and then valve actuating rod C, Figure 21, and remove the rod. Be extremely careful not to allow dirt to enter the transmission.
4. Remove the expansion reservoir filler cap and add "Type A" transmission fluid until the reservoir is $\frac{1}{2}$ full.
5. Jack up rear of the tractor, start the engine and operate at a slow idle speed.
6. With engine running, move speed control lever to both forward and reverse positions until oil appears at the free-wheeling valve hole.
7. Replace free-wheeling valve actuating rod C and tighten nut B, Figure 21, to 30 inch-pounds. Tighten both parts carefully to prevent the small rubber o-rings inside the cap from becoming damaged.

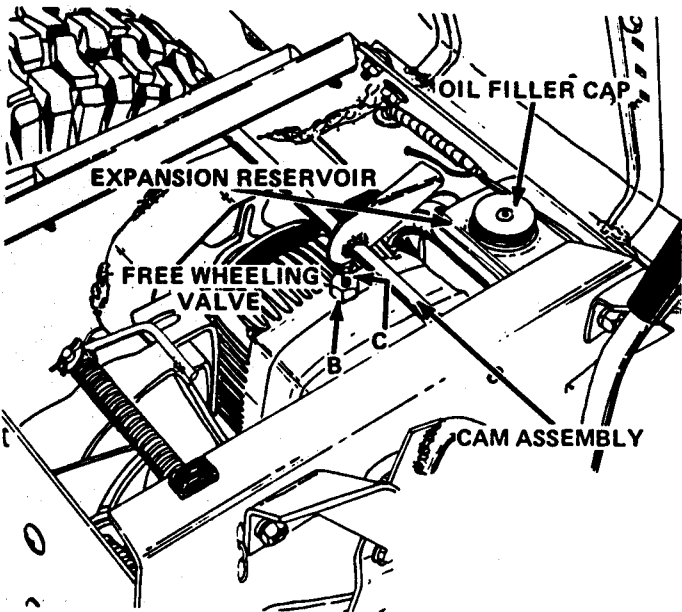

Figure 21

8. Replace cam assembly, Figure 22. Tighten nuts A so the cam arm intersects the center of the valve actuating rod and the shaft has 1/32" end play.
9. Recheck the oil level. If necessary add oil until the reservoir is half full.

NOTE: THE CAM ARM MUST BE IN THE FORWARD POSITION BEFORE THE TRACTOR CAN BE OPERATED.

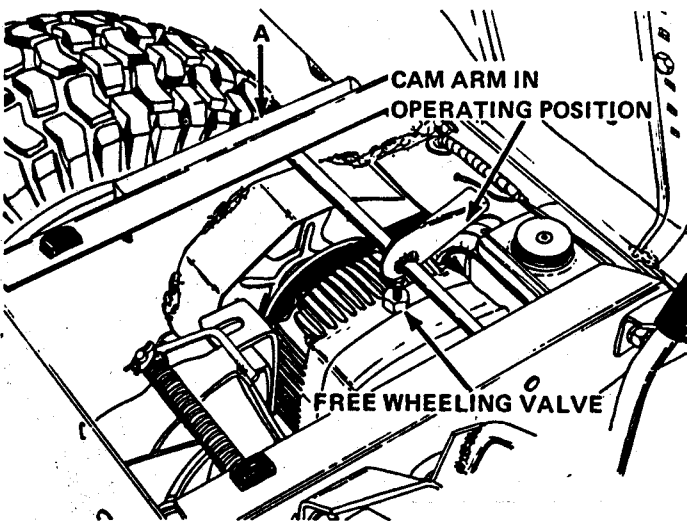

Figure 22

BATTERY SERVICE

Check the battery electrolyte level once each week or every 25 hours of operation. Check it monthly if the tractor is idle or is in storage. Add distilled water to bring the level to the bottom of the split ring in the filler tube of each cell.

Each spring and fall clean the battery and terminals with ammonia or bicarbonate of soda solution followed by flushing with clean water. Keeping the battery clean will prolong battery life. After cleaning, apply a light coat of grease to the terminal and cable ends.

Keep cable clamps securely tightened to terminals and keep battery hold-down clamps tight to prevent vibration but do not overtighten as this could warp the case.



WARNING: STORAGE BATTERIES GIVE OFF HIGHLY INFLAMMABLE HYDROGEN GAS. DO NOT ALLOW SPARKS OR FLAME NEAR BATTERY. DO NOT LAY TOOLS ACROSS BATTERY TERMINALS WHICH MAY CAUSE A SPARK RESULTING IN AN EXPLOSION.

Maintain the battery at full charge during storage and during the winter months to prevent freezing. When water is added during freezing weather, run the engine at least one hour to bring the battery up to a full state of charge.

NOTE: Figures 26 and 27 show the right rear tractor tire removed for clarity and for easier access to the brake adjustment.

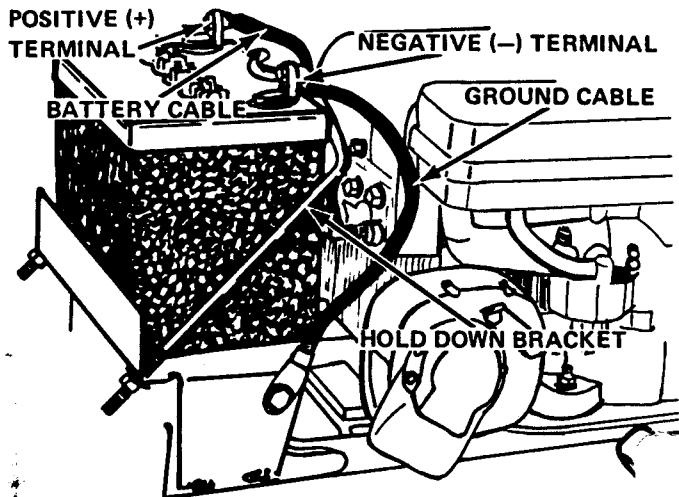

Figure 23

When installing the battery, make certain the ground cable is connected to the negative (-) terminal on the battery, see Figure 23. Be sure the battery cable is connected to the positive (+) terminal.

IMPORTANT: REVERSED BATTERY CABLES OR REVERSED CABLES FROM A BATTERY CHARGER OR BOOSTER BATTERY CAN BLOW THE 7½ AMP FUSE SHOWN IN FIGURE 24. ALWAYS DISCONNECT THE TERMINAL AT THE FUSE WHEN CHARGING THE BATTERY OR WHEN ELECTRIC WELDING IS DONE ON THE TRACTOR.

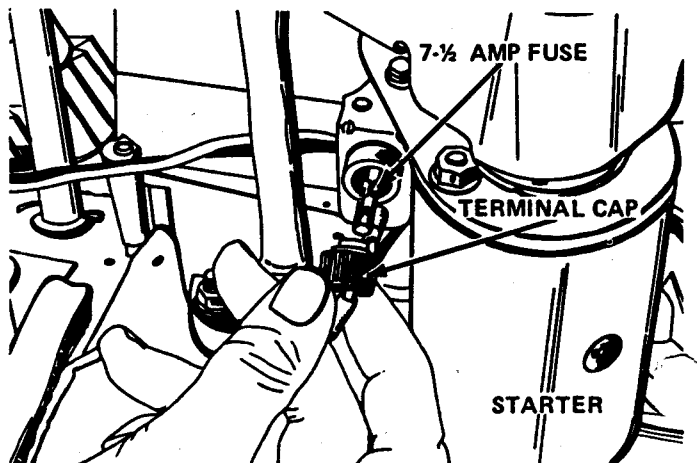

Figure 24

FUEL FILTER SERVICE

When dirt or other foreign material is allowed to enter the fuel tank it will collect in the fuel filter eventually causing fuel stoppage. If this occurs, disassemble and clean the filter, Figure 25.

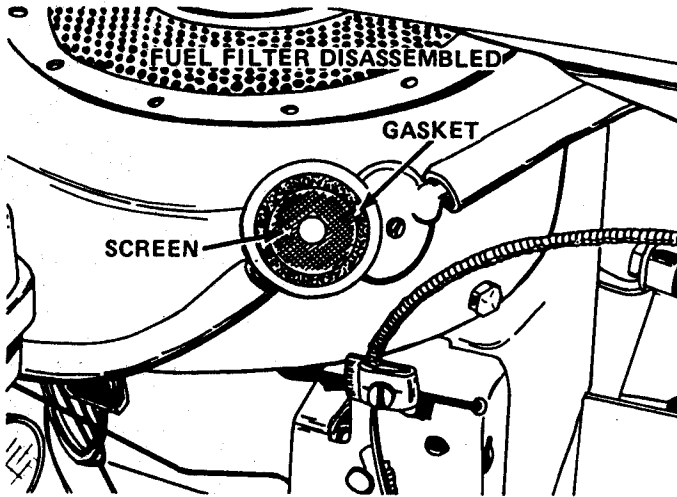

Figure 25

TIRE PRESSURES

Check tire pressures at least once each month. Inflate tires to pressures shown in the chart. Use a low pressure tire gauge for accurate readings.

Keep tires properly inflated at all times. Over-inflation will cause operator discomfort. Under-inflation will cause short tire life. Always see that the tire valve caps are in place and securely tightened to prevent air loss.

DESCRIPTION	LAWN WORK	SNOW THROWER AND FRONT BLADE WORK
Front tires (15 X 6.00-6)	10	12
Rear tires (20 x 8.00-10)	6	6

ADJUSTMENTS

BRAKE ADJUSTMENT

If the brake does not hold or stop the tractor, or if it is extremely difficult to engage the brake lock, it is necessary to adjust the brake. Use the following procedure.

1. Depress clutch brake pedal and engage the brake lock to hold brake in the engaged position.
2. Tighten nuts A, Figure 26, until the compression spring measures 1 1/4 inch.

NOTE: Nuts B must not touch the support when making the adjustment. Allow at least 1/16" clearance between nuts B and the support when adjusting the spring length.

3. Release brake lock and allow the brake pedal to return to its normal position against the stop.

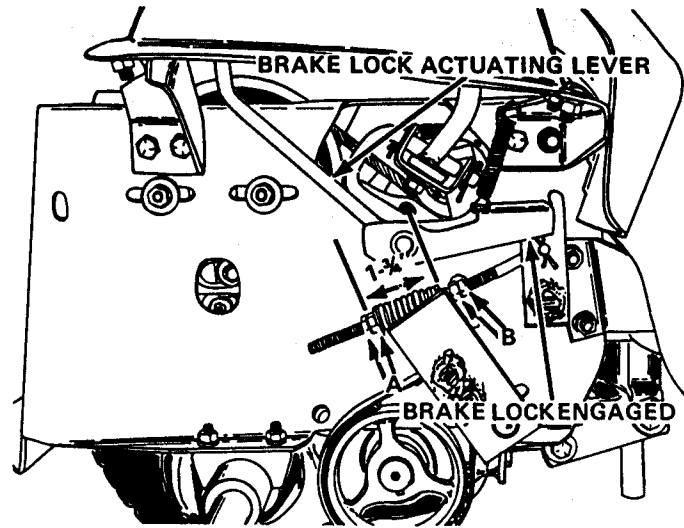

Figure 26

4. Tighten nuts B, Figure 27, until compression spring measures as follows:

Hydrostatic models – 2-1/8"
Gear shift models – 1-15/16"

NOTE: The clutch free-travel may be affected after adjusting the brake. Adjust if necessary as outlined under "Clutch Free Travel Adjustment."

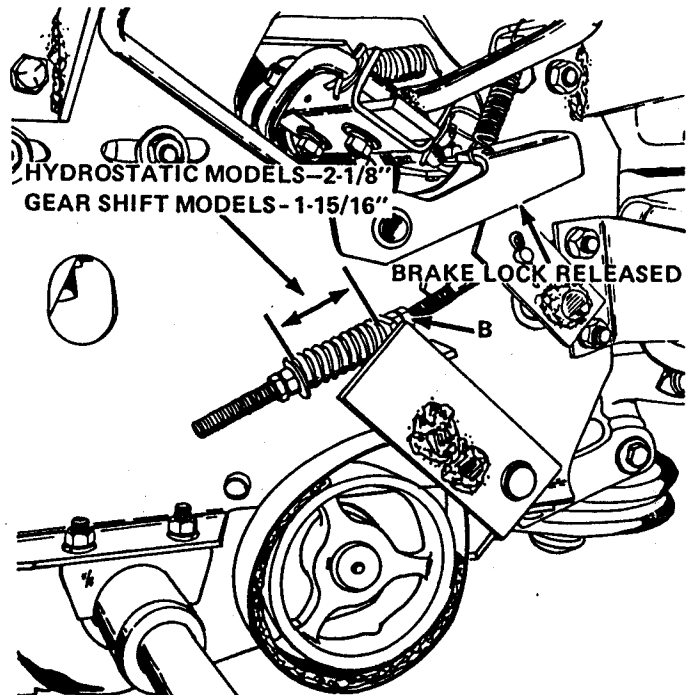

Figure 27

CLUTCH FREE TRAVEL ADJUSTMENT (Gear Shift Models)

The clutch rod must be adjusted to insure that the transmission drive belt is fully engaged when the clutch brake pedal is released.

To adjust the free travel, move nuts A, Figure 28, front or back so that when depressing the clutch brake pedal the support angle moves forward 3/16" before bolt B contacts the front of the slot in the clutching link.

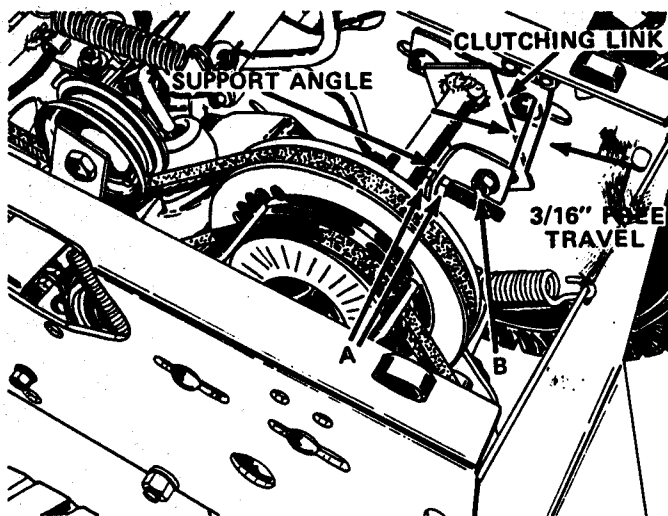

Figure 28

TRANSMISSION DRIVE BELT (Gear Shift Models)

The transmission drive belt idler should be adjusted if the drive belt slips or if the spring coils have bottomed out. See Figure 29. Adjust by loosening bolt A and moving the idler back in the slotted hole of the mounting bracket until the belt does not slip and until there is clearance between the spring coils. Before tightening bolt A, place the belt guide 1/8" from the belt in such a position that it does not bind the belt in any position of the idler.

Check belt guide D, Figure 30. It should be positioned 1/8" from the belt at the point where the belt enters the drive sheave. Adjust by loosening the mounting bolt A and positioning the guide as required.

NOTE: The clutch free-travel may be affected after adjusting the drive belt idler. Adjust if necessary as outlined under "Clutch Free Travel Adjustment."

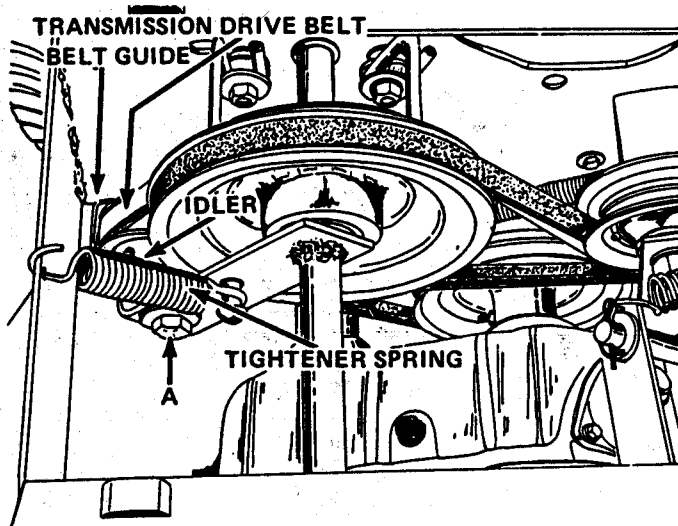

Figure 29

INTERMEDIATE SHAFT DRIVE BELT (Gear Shift Models)

The intermediate shaft drive belt should be tightened if it begins to slip or before the idler bracket contacts the stop bolt as shown in Figure 30.

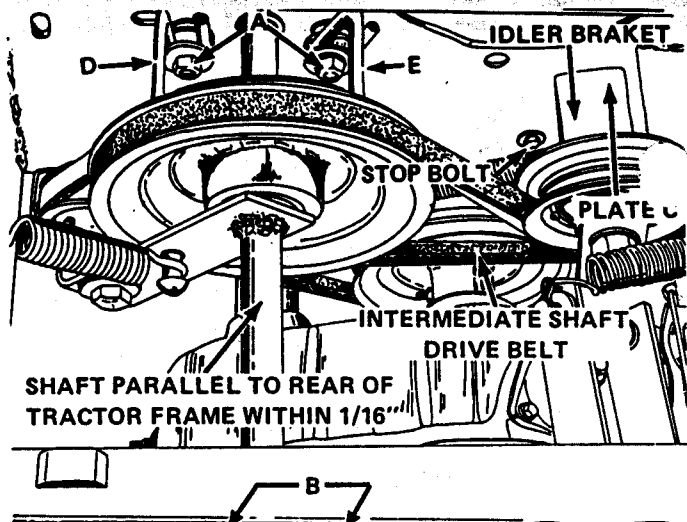

Figure 30

To adjust the belt tension, loosen the four intermediate shaft mounting bolts A and B, Figure 30, and move the shaft rearward keeping it parallel to the rear of the tractor frame until the front edge of the idler bracket is flush with the plate identified at C.

NOTE: THE SHAFT MUST BE PARALLEL TO THE TRACTOR FRAME WITHIN 1/16 INCH.

Adjust belt guides D and E 1/8" from the belt at the points where the belt is tangent to the sheave and tighten the shaft mounting bolts A and B.

NOTE: The clutch free-travel adjustment can be affected after tightening this belt. Re-adjust as previously outlined if necessary.

PTO DRIVE BELT (Implement Power)

The PTO drive belt should be adjusted before the rear nuts B, Figure 31, contact the pivot block when the implement power clutch is engaged or if the belt begins to slip.

Use the following procedure to adjust the belt:

1. Engage implement power clutch and tighten nuts C, Figure 31, until the spring length is 2-5/8".

NOTE: When making this adjustment, there must be clearance between the rear nuts B and the pivot block. Move nuts B rearward if necessary to obtain this clearance before measuring the spring length.

2. Position belt guides D and E, Figure 32, across from one another when the clutch is disengaged in such a manner that the belt is retained in the disengaged position. In addition, guide D must clear the engine sheave by 1/8" as the clutch is moved from the disengaged to the engaged position. Move guide D rearward if necessary to obtain this clearance.

3. With clutch disengaged, tighten nuts B, Figure 31, to obtain 1/4" clearance between the implement power clutch lever and rear of slot in the tractor frame.

PTO DRIVE OVERCENTER ASSEMBLY

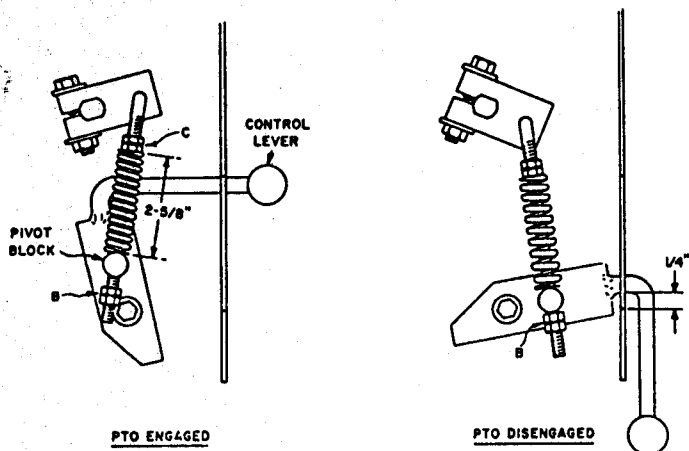

Figure 31

If after adjustment, the rear nuts B, Figure 31, contact the pivot block when the clutch is engaged, loosen bolt F, Figure 32, and move the idler closer to the belt to provide additional adjustment. Repeat the complete adjustment sequence if it becomes necessary to move the idler.

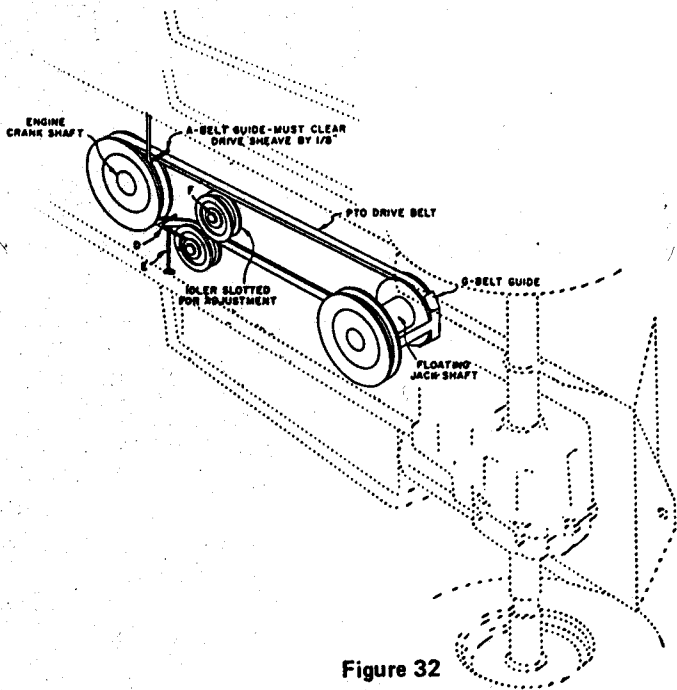

Figure 32

HYDROSTATIC TRANSMISSION DRIVE BELT (HYDROSTATIC MODEL ONLY)

The hydrostatic drive belt does not require tightening. Belt tension is achieved by a spring-loaded idler. Replace the belt if it has stretched or worn to the point where it begins to slip.

HYDROSTATIC NEUTRALIZER PEDAL ADJUSTMENT (HYDROSTATIC MODEL ONLY)

The linkage should be adjusted to automatically return the hydrostatic control lever to the "park-start" (neutral) position when the neutralizer pedal is depressed.

To adjust the neutralizer pedal, place control lever in the "park-start" position, loosen bolt A, Figure 33, depress the foot pedal and apply the brake lock, then retighten bolt A.

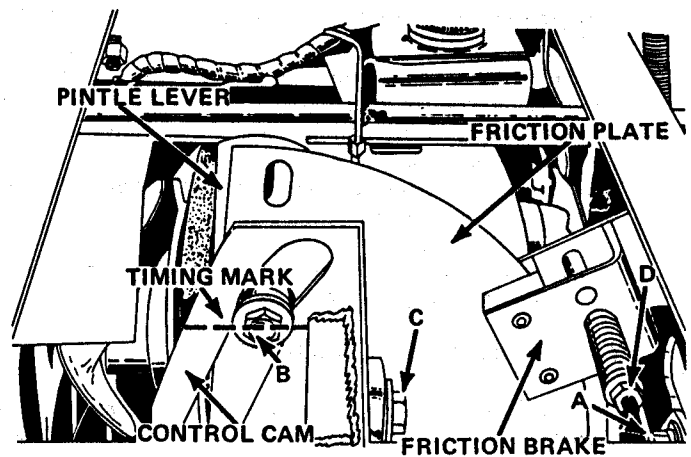

Figure 33

Release brake lock, move the control lever to a forward position then depress the foot pedal. The control lever should return to "park-start" (neutral). Repeat process by placing control lever in reverse. When the adjustment is properly made, the control lever will automatically return to neutral from either forward or reverse when the neutralizer pedal is depressed.

IMPORTANT: NEVER DEPRESS BRAKE PEDAL AND MOVE THE HYDROSTATIC CONTROL SIMULTANEOUSLY. THE LINKAGE IS INTERCONNECTED AND DAMAGE OR MIS-ADJUSTED LINKAGE COULD RESULT.

HYDROSTATIC NEUTRAL ADJUSTMENT (HYDROSTATIC MODEL ONLY)

The hydrostatic controls should be adjusted so the rear tires stop rotating when the control lever is returned to neutral either manually or with the neutralizer pedal.

Use the following procedure to adjust neutral:

1. Check HYDROSTATIC NEUTRALIZER PEDAL ADJUSTMENT. If required, adjust as previously explained.
2. Check position of the timing mark on control cam. With the shift lever in the "park-start" position and brake lock engaged, the center line of bolt head B, Figure 33, should be aligned with the timing mark on the cam. If the timing mark does not align with the bolt head, loosen bolt C and move the cam up or down as required to align the bolt head with the timing mark. Tighten nut C securely after making the adjustment.
3. Jack up rear of the tractor until rear tires are clear of the ground.
4. Start engine and increase speed to full throttle.
5. Loosen bolt B slightly. Insert a screw driver through the slots in the friction plate and the pintle lever, Figure 33. Pivot the pintle lever left or right until the rear tires stop rotating and retighten bolt B.

WARNING: KEEP HANDS AND ANY LOOSE CLOTHING AWAY FROM THE HYDROSTATIC COOLING FAN AND DRIVE BELT WHEN MAKING ADJUSTMENT. THESE PARTS MUST ROTATE WHEN MAKING THE NEUTRAL ADJUSTMENT.



HYDROSTATIC CONTROL LEVER BRAKE ADJUSTMENT

The hydrostatic control lever friction brake must be adjusted so the control lever moves through the "forward" and "reverse" modes with a minimum of force. However, due to the neutral tendency of a hydrostatic transmission to neutralize, the brake must be tightened sufficiently so the tractor maintains any selected speed setting.

To adjust the friction brake, tighten or loosen bolt D, Figure 33, until the proper braking is reached.

FRONT WHEEL TOE-IN ADJUSTMENT

Proper toe-in of the front wheels is necessary to assure proper steering and to reduce tire wear. Correct toe-in is when the front of the wheels are 1/8" to 1/16" closer together than the rear of the wheels (measured at the horizontal center line of the rim flanges).

If the steering develops a wandering characteristic or if excessive tire wear develops, the toe-in of the front wheels should be checked. If the toe-in is not correct, adjust as follows:

1. Turn steering wheel until the rear edge of the tie rod connecting link is perpendicular (90 degrees) to the tractor frame as shown in Figure 34.
2. Adjust length of tie rods until distances A and B are equal and so distance C is between 1/8" to 1/16" less than distance D.

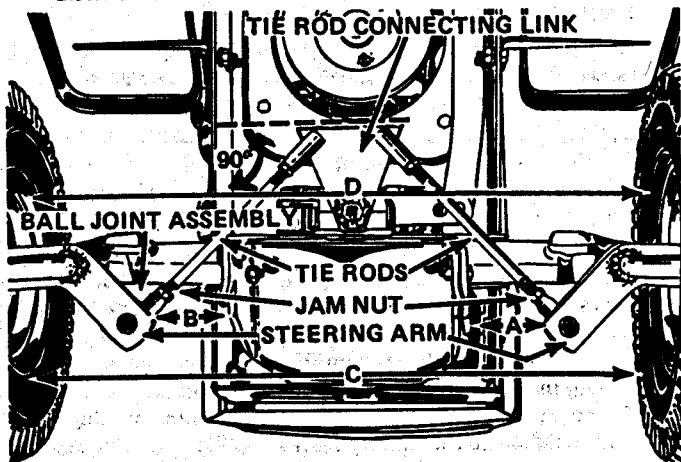

Figure 34

NOTE: Use following procedure to shorten or lengthen tie rods:

1. Loosen jam nuts on both ends of tie rods, Figure 34.
2. Rotate tie rods until distances A and B, Figure 34, are equal and distance C is 1/8" to 1/16" less than D.
3. Tighten jam nuts securely.

SEAT ADJUSTMENT

The seat is adjustable front or back to any one of six different positions. Adjustment is made by removing the four mounting bolts located under the seat, moving the seat to the most comfortable position and then replacing the mounting bolts in the appropriate holes.

BELT REPLACEMENT

If it becomes necessary to replace one of the tractor drive belts, the following diagrams show the proper placement of the belts and belt guides. After installing a belt it will be necessary to follow the adjustment procedures outlined in the ADJUSTMENT section of this manual.

PTO DRIVE BELT - (Figure 32)

1. Adjust guide A to clear the engine drive sheave by 1/8 inch.
2. Adjust guide G to clear the floating jackshaft sheave by 1/8 inch.
3. Position idler F to provide least amount of belt tension when installing a new belt.
4. Adjust belt tension and guides D and E using the procedure outlined in "Maintenance and Adjustment" section.

MECHANICAL TRANSMISSION DRIVE BELTS - (Figure 35)

Intermediate Shaft Drive Belt

Follow the instructions outlined in the ADJUSTMENT section.

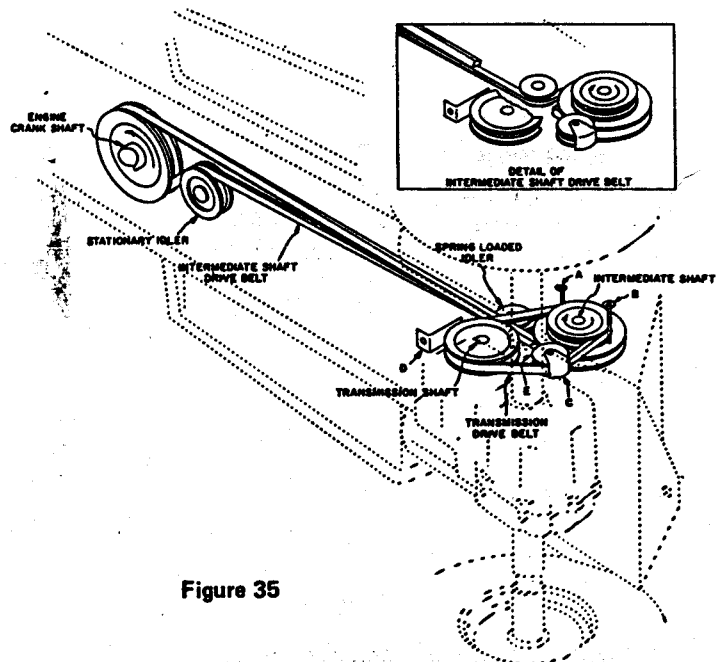

Figure 35

Transmission Drive Belt (Figure 35)

1. Position guides A and B 1/8" from drive sheave at the points where belt is tangent to the sheave.
2. Position guide D, 1/8" from the transmission sheave.
3. Idler E is mounted in a slotted hole. Position to provide least amount of belt tension when installing a new belt.
4. Place guide C 1/8" from the belt in such a position that it does not bind the belt in any position of the idler.
5. Adjust belt tension using the procedure outlined in ADJUSTMENT section.

**HYDROSTATIC TRANSMISSION DRIVE BELT –
(Figure 36)**

No adjustments are necessary when replacing the hydrostatic transmission drive belt. Belt tension is maintained by the spring-loaded idler.

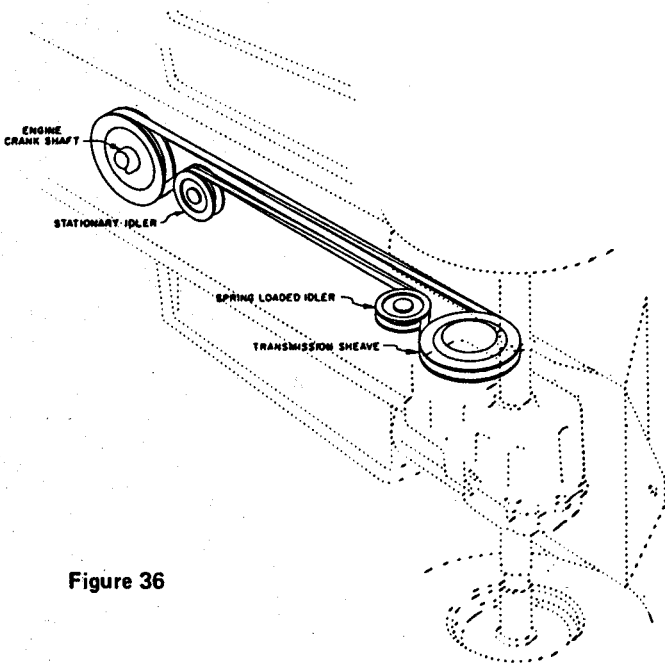

Figure 36

STORAGE

PREPARATION FOR STORAGE

1. Remove all oil, grease and dirt from engine and transmission.
2. Clean the tractor exterior and tires thoroughly, removing all mud, dirt and grease.
3. Touch up all unpainted and exposed areas with paint to prevent rust.
4. Change engine oil.
5. Disconnect fuel line at fuel filter and drain fuel tank. Run the engine until the fuel is exhausted from the system. Clean the fuel filter.
6. Remove and clean battery. Check electrolyte level and have battery fully charged. Store battery in a cool, dry place where it will not freeze.
7. Remove the spark plug and pour one tablespoonful of SAE 30 oil into the cylinder. Turn engine over manually at least two revolutions.
8. Re-gap spark plug. Replace if required.
9. Check transmission and differential oil levels. Add oil as required. Lubricate tractor thoroughly.
10. Store tractor in a cool, dry place to reduce tire deterioration. Block up tractor to take the weight off the tires.

11. Inspect tractor for visible signs of wear, breakage or damage. Order any parts required and make necessary repairs to avoid delays when starting next season.

NOTE: Your authorized Ariens dealer is trained and equipped to service your tractor. A periodic check-up by your dealer will help to reduce your maintenance costs.

PREPARATION FOR USE AFTER STORAGE

1. Replace battery and check electrolyte level.
2. Fill fuel tank with fresh, clean regular gasoline.
3. Check transmission, differential and engine oil levels.
4. Check tire inflation.

36 RM ROTARY MOWER

The Model 36 RM Rotary Mower is standard equipment on both the S-8 Gear Shift and Hydrostatic tractors.

ATTACHING THE MOWER TO THE TRACTOR

Use the following procedure to attach the mower to the tractor:

1. Remove ignition key. Place implement power clutch lever in the "disengaged" position and "engage" the tractor brake lock.

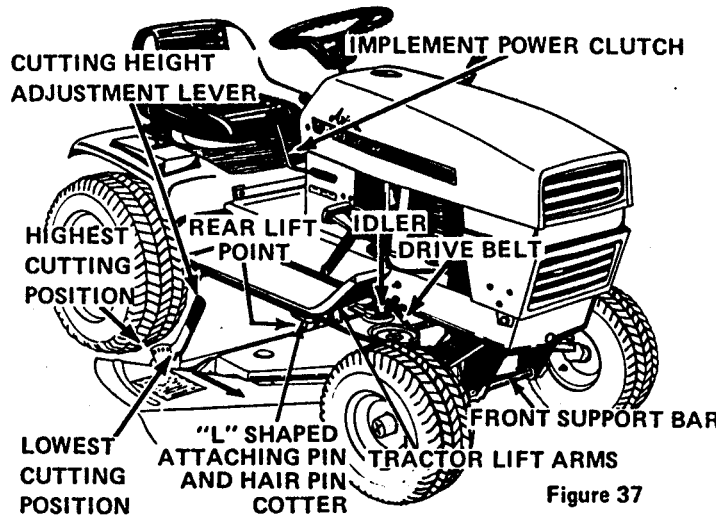

Figure 37

2. Raise the tractor attachment lift lever. Figure 7.
3. Place cutting height adjustment lever in the second lowest cutting position, see Figure 37.
4. Raise front support bar to clear the front tractor tire and slide the mower under the tractor from the right side.
5. Place the drive belt over the rear lift point and lower the attachment lift lever. Align ball joint of rear lift point to tractor lift arms and secure with the "L" shape attaching pin and hairpin cotter provided, Figure 37.

6. Position drive belt over the drive and driven sheaves and place idler to the inside of the belt as shown in Figure 37.

7. Position front support bar in the tractor saddle brackets and secure with the locks and latches, see Figure 38.

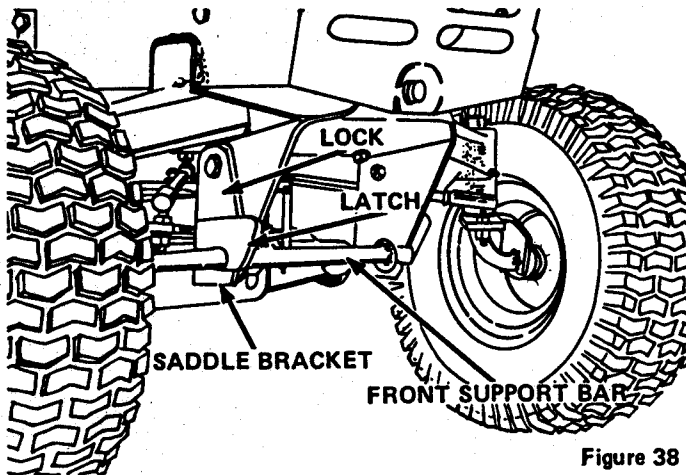

Figure 38

REMOVING MOWER FROM THE TRACTOR

Reverse the attaching procedure to remove the mower from the tractor.

BEFORE OPERATING THE TRACTOR

Before operating your rotary mower, carefully read this manual. Become thoroughly familiar with the controls, safety precautions and proper operating procedures. The more familiar you become with the tractor and mower the better results you will have.

Use the following procedure to operate the mower:

1. Move cutting height adjustment lever, Figure 37, to one of the six positions available to obtain the desired height of cut.
2. Raise the mower by pulling the attachment lift lever rearward until the lock snaps in place.
3. Start the engine as outlined in the TRACTOR OPERATION section.
4. Drive tractor to the work area before starting the mower.
5. Slowly engage the implement power clutch with the engine running at $\frac{1}{2}$ throttle. Increase engine speed to full throttle after the blades are rotating.



CAUTION: KEEP BYSTANDERS AWAY FROM THE AREA WHILE THE BLADES ARE ROTATING.

6. The mower blade speed is directly related to the engine speed. For best mowing results, OPERATE ENGINE SPEED AT FULL THROTTLE. Regulate travel speed on hydrostatic models with the hydrostatic control lever. Regulate travel speed on gear shift models by selecting an appropriate gear. The power requirement increases in dense, high grass conditions. If travel speed of the tractor is too fast for mowing conditions, the engine and thus the mower will slow down reducing the cutting efficiency of the mower. In some conditions, excessive FORWARD

travel speeds may cause the engine to stall and the mower to plug or a drive belt to slip.

7. For any emergency or "panic" stops, depress the clutch brake pedal on gear shift models or the neutralizer and brake pedal on the hydrostatic models.

NOTE: KEEP FOOT OFF PEDAL DURING NORMAL OPERATION. NEVER USE PEDAL AND HYDROSTATIC CONTROL LEVER SIMULTANEOUSLY AS THE PARTS ARE INTER-CONNECTED AND THE LINKAGE COULD BECOME DAMAGED OR MISADJUSTED. ON GEAR SHIFT MODELS, BELT SLIPPAGE COULD OCCUR.

MOWER ADJUSTMENTS AND MAINTENANCE



BE CAREFUL: NEVER ATTEMPT TO SERVICE OR MAKE ANY ADJUSTMENTS TO THE MOWER WHILE THE ENGINE IS RUNNING. WHEN SERVICING OR MAKING ADJUSTMENTS, IT IS A GOOD PRACTICE TO USE THE FOLLOWING PROCEDURE:

1. Disengage implement power clutch.
2. Hydrostatic models — Place hydrostatic control lever in the "park-start" position and apply brake lock.
Gear shift models — Place gear shift lever in first gear and apply brake lock.
3. Lower the mower.
4. Stop engine and remove ignition key.
5. Disconnect spark plug wire.

ADJUSTING BLADE LEVEL AND PITCH

Proper leveling of the blades is essential in obtaining a smooth, evenly cut lawn. Blade pitch is correct when the front blade tips are slightly lower than the rear blade tips. Improper pitch adjustment will affect engine power requirements and can cause uneven cutting.

Use the following procedure to adjust blade level and pitch:

1. Check tire pressure and adjust as required (front tires — 10 lbs.; rear tires — 6 lbs.)
2. Place tractor on a smooth level surface, preferably a concrete slab or smooth floor.
3. Place cutting height adjustment lever, Figure 37, in the highest cutting position.
4. With the attachment lift lever, lower the mower so the roller assembly firmly rests on the floor.
5. Rotate the blades until they are parallel to the roller assembly as shown in Figure 39. Measure distances A and B (from end of blade tips to the floor). These distances should be equal. If they are not equal, loosen roller assembly adjusting bolt C or D and pivot the mower down or up until distances A and B are equal with the roller resting firmly on the floor.

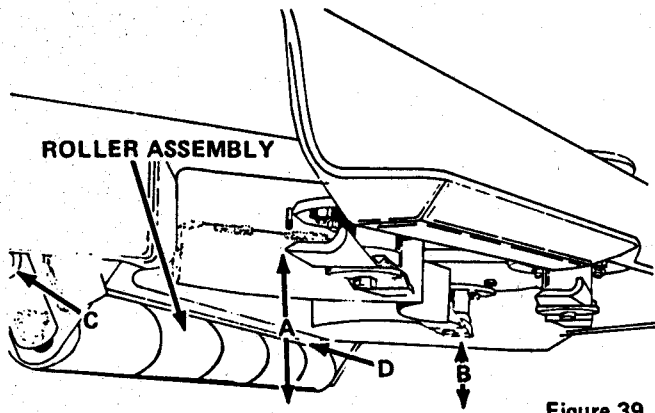

Figure 39

NOTE: If there are any indications of damage to the mower deck, blades or blade spindles, measure the blade tips at A and B, then rotate the blades 180 degrees and measure the opposite blade tip ends. If the measurements vary more than 1/8" on any blade, see your Ariens dealer for service. If the variation is not excessive, level the mower using the lowest measurement from blade tip to ground at A and B.

6. Tighten roller assembly mounting bolts securely.
7. Rotate the blades until they are perpendicular to the roller assembly as shown in Figure 40.
8. Measure distances A (from both outboard tips to the floor). Then measure distance B. The front blade tip (distance B) should be 1/8" less than the rear blade tip (distance A). Loosen both front support mounting bolts C and pivot front of mower "up" or "down" until the front blade tip B is 1/8" closer to the floor than the rear blade tips A.

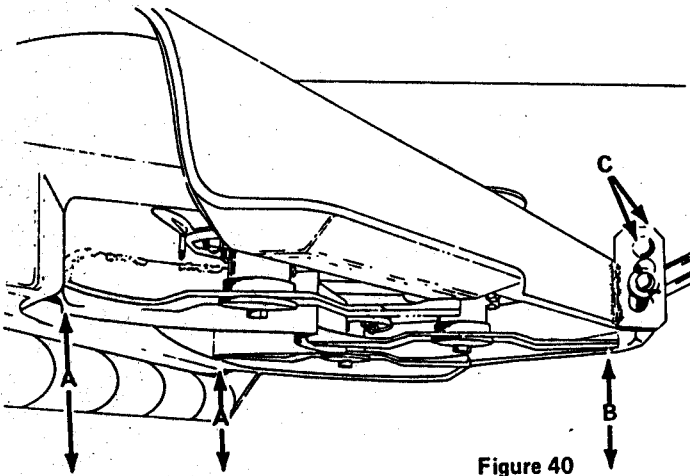

Figure 40

CUTTING HEIGHT

The cutting height is adjustable to any of six different positions by moving the cutting height adjustment lever shown in Figure 37. Raise the lever to decrease cutting height. Lower the lever to increase cutting height.

MOWER DRIVE BELT REPLACEMENT

Constant tension is maintained on the drive belt by a spring-loaded idler. Therefore, belt adjustment is not required.

Figure 41 shows the correct belt rotating (with shield removed) in case it ever becomes necessary to replace a worn or damaged belt.

MOWER BLADE CARE

Blades should be kept sharp and tightly mounted at all times. They can be sharpened on the mower with a file or removed and sharpened on a grinding wheel.

IMPORTANT: ALWAYS FOLLOW THE ORIGINAL CUTTING EDGE BEVEL WHEN SHARPENING THE BLADES AND SHARPEN BOTH ENDS EVENLY TO MAINTAIN PROPER BALANCE!

Special "cupped" washers help protect the mower by allowing the blade to slip on the spindles if a solid object is struck.

NOTE: WHEN REPLACING A BLADE, ALWAYS INSTALL THE SPECIAL "CUPPED" WASHER WITH THE CONCAVE SIDE FACING THE BLADE AND TIGHTEN THE BLADE MOUNTING BOLTS TO 50-60 FT-LBS TORQUE.

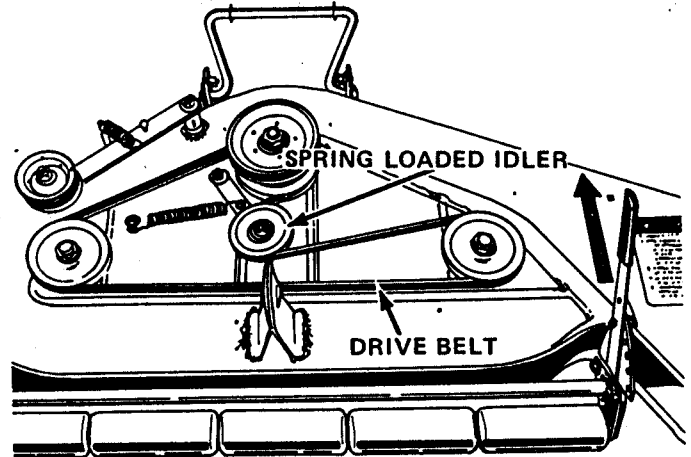

FIGURE 41

STORING THE MOWER

The following maintenance is recommended at the end of each mowing season.

1. Remove mower from the tractor using the procedure outlined in this manual.
2. Remove all buildup of material under the deck.
3. Remove rust from any exposed metal and cover the areas with paint or a light coat of oil.
4. Store the mower in a dry place.

OPTIONAL EQUIPMENT – MULCHING KIT

An optional mulching kit is available for the 36 RM Rotary Mower. This kit can be used when grass or leaves are to be finely chopped and discharged into the stubble under mower deck rather than through the discharge opening.

FRAME, STEERING, FRONT AXLE, FRONT WHEEL & SPINDLE

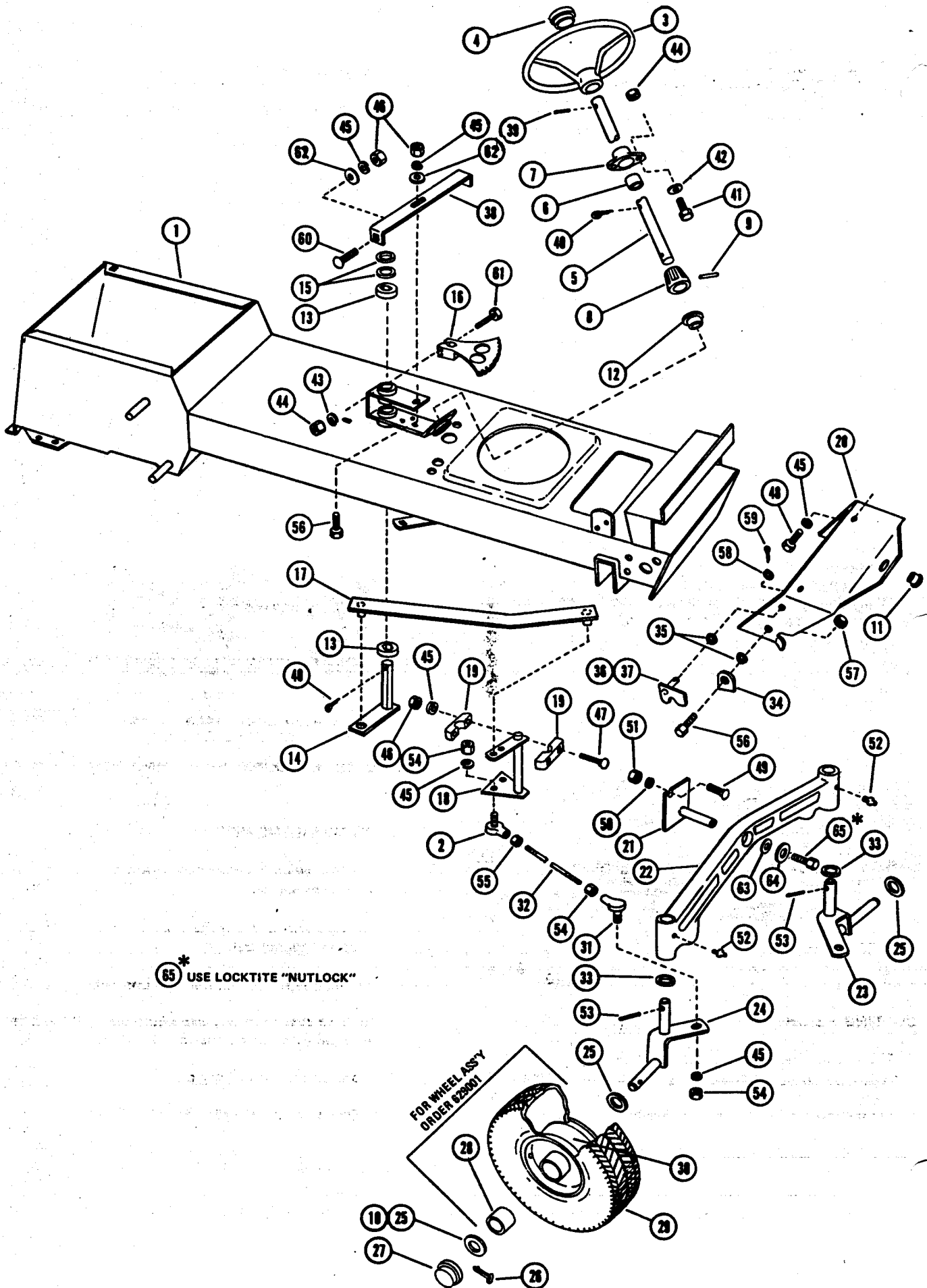

FRAME, STEERING, FRONT AXLE, FRONT WHEEL & SPINDLE

REF NO.	PART NO.	DESCRIPTION	929001	929002	REF NO.	PART NO.	DESCRIPTION	929001	929002
1	029002	FRAME, Gear	1		33	075059	WASHER, Thrust	2	2
	529009	FRAME, Hydrostatic		1	34	029013	LOCK STRIP	2	2
2	029158	L.H. BALL JOINT	2	2	35	029024	WASHER, Spring	4	4
3	629007	STEERING WHEEL W/Cap	1	1	36	029015	LATCH, L.H.	1	1
4	029163	CAP	1	1	37	029014	LATCH, R.H.	1	1
5	029020	STEERING COLUMN	1	1	38	029018	BRACKET	1	1
6	029023	SPACER	1	1	39	058004	PIN, Spring, 1/4" x 1-1/2"	1	1
7	054025	BEARING, Side Flange	1	1	40	067006	PIN, Cotter, 3/16" x 1-1/4"	2	2
8	029021	PINION GEAR	1	1	41	059003	CAP SCREW, HH, 5/16" - 18 x 1	2	2
9	029133	NEEDLE ROLLER	1	1	42	064002	WASHER, Flat, 5/16"	2	2
10	064095	WASHER, Special	3 (AR)	3	43	063003	LOCKWASHER, 5/16"	4	4
11	055076	BUSHING' Nylon	1	1	44	065015	NUT, Hex, 5/16" - 18	4	4
12	055080	BUSHING	1	1	45	063021	LOCKWASHER, 3/8"	13	13
13	055083	BUSHING, Hex Bore	2	2	46	065018	NUT, Hex, 3/8" - 16	7	7
14	029017	ARM & SHAFT	1	1	47	062005	BOLT, Carriage, 3/8" - 16 x 2-1/2"	4	4
15	064111	WASHER, 7/8" I.D. x 1-1/4" O.D.	2	2	48	059133	CAP SCREW, HH, 3/8" - 16 x 1-1/4" 2 Grade 5	2	2
16	029019	BEVEL GEAR SEGMENT	1	1	49	062012	BOLT, Carriage, 1/4" - 20 x 3/4"	1	1
17	029012	LINK	1	1	50	063002	LOCKWASHER, 1/4"	1	1
18	029010	CRANK	1	1	51	065032	NUT, Hex, 1/4" - 20	1	1
19	029011	BLOCK	4	4	52	022093	FITTING, Grease	2	2
20	029007	MOUNTING, Front	1	1	53	058050	PIN, Grooved, 1/4" x 1-1/4" Type E	2	2
21	029006	AXLE PIVOT	1	1	54	065005	NUT, Hex, 3/8" x 24 UNF.	6	6
22	029005	AXLE, Front	1	1	55	065073	NUT, Hex, 3/8" - 24 UNF L.H.	2	2
23	029008	SPINDLE, L.H.	1	1	56	059004	CAP SCREW, HH, 3/8" - 16 x 1"	3	3
24	029009	SPINDLE, R.H.	1	1	57	065039	LOCKNUT, Hex, 3/8" - 16	2	2
25	064109	WASHER, Special	4	4	58	064043	WASHER, Flat, 3/8"	4 (AR)	4
26	067027	COTTER, "T" Head	2	2	59	067024	PIN, Cotter, 1/8" x 3/4"	2	2
27	029173	GREASE CAP	2	2	60	062029	BOLT, Carriage, 3/8" - 16 x 1"	2	2
	629001	WHEEL ASS'Y (Consists of)	2	2	61	059128	CAP SCREW, HH, 5/16" - 18 x 1-3/4" Grade 5	2	2
28		055086 BUSHING	2	2	62	064008	WASHER, Flat, 3/8"	3	3
29		071099 TIRE, 15 x 6.00	1	1	63	064041	WASHER	1	1
30		071100 WHEEL	1	1	64	064102	WASHER	1	1
31	029171	BALL JOINT, R.H.	2	2	65	059004	CAP SCREW	1	1
32	029016	TIE ROD	2	2					

HOOD, REAR DECK, SEAT, DASH SUPPORT, RUNNING BOARD

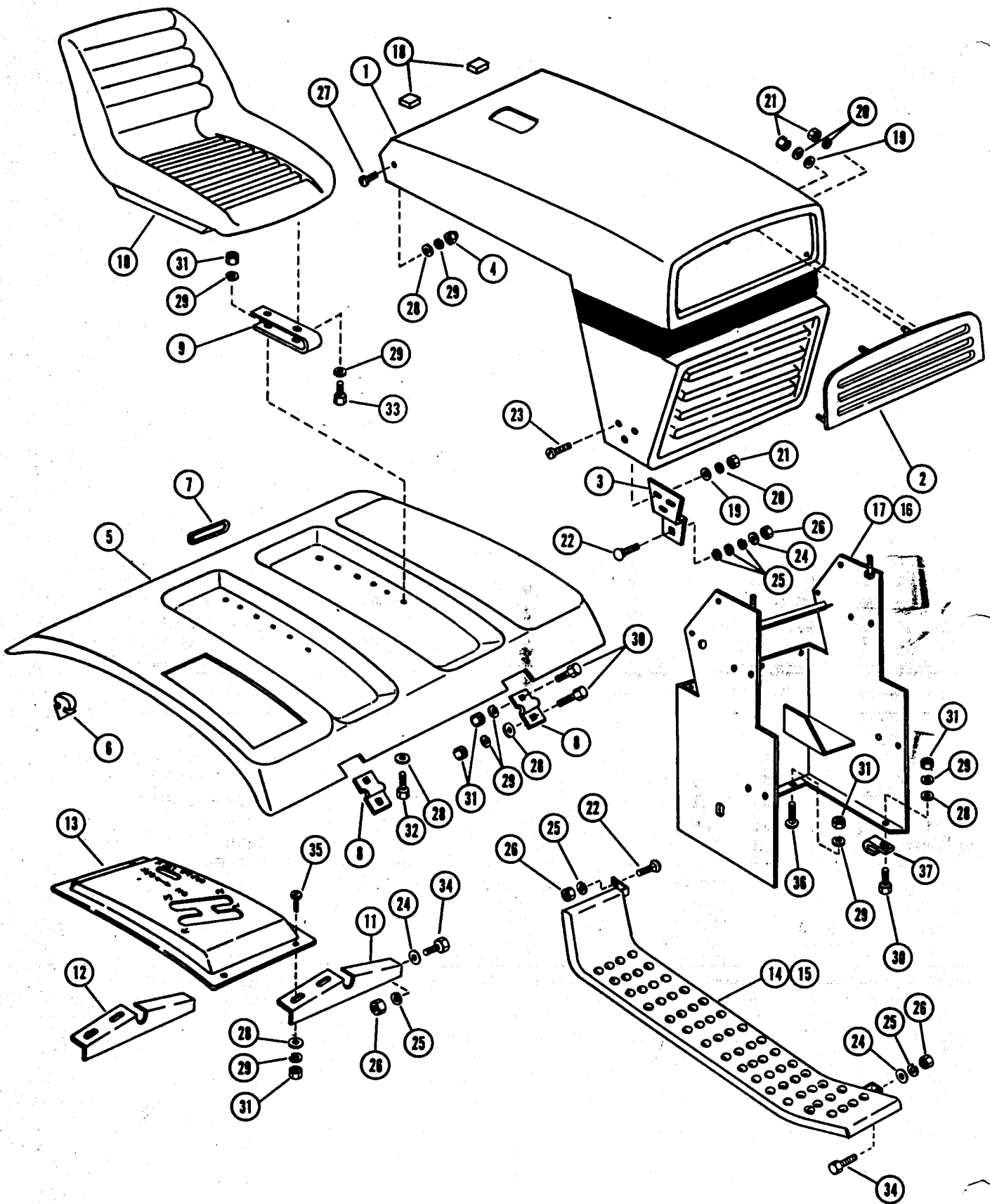

HOOD, REAR DECK, SEAT, DASH SUPPORT, RUNNING BOARD

REF NO.	PART NO.	DESCRIPTION	929001	929002
1	529007	HOOD (Gear)	1	
	529008	HOOD (Hydro)		1
2	029124	GRILL INSERT	1	1
3	029122	HINGE, Hood	2	2
4	065095	NUT, Crown 5/16" - 18	2	2
5	029119	REAR DECK	1	1
6	075054	BUMPER, Rubber	2	2
7	029134	REFLECTOR, Tail	1	1
8	029123	HINGE	2	2
9	029038	SPRING	2	2
10	029127	SEAT	1	1
11	029107	SUPPORT, Front	1	1
12	029106	SUPPORT, Rear	1	1
13	029120	CONSOLE, (Gear)	1	
	029121	CONSOLE (Hydrostatic)		1
14	029254	RUNNING BOARD, L.H.	1	1
15	029253	RUNNING BOARD, R.H.	1	1
16	529006	BASE (Gear)	1	
17	529005	BASE (Hydro)		1
18	075058	STOP (Pressure Sensitive Backing)	2	2
19	064007	WASHER, Flat, 1/4"	8	8
20	063002	LOCKWASHER, 1/4"	10	10
21	065032	NUT, Hex, 1/4" - 20	10	10
22	062029	BOLT, Carriage, 3/8" - 16 x 1"	6	6
23	061041	SCREW, Machine, 1/4" - 20 x 5/8"	6	6
24	064008	WASHER, Flat, 3/8"	10	10
25	063021	LOCKWASHER, 3/8"	18	18
26	065018	NUT, Hex, 3/8" - 16	14	14
27	061045	SCREW, Machine, 5/16" - 18 x 1/2"	2	2
28	064002	WASHER, Flat, 5/16"	14	14
29	063003	LOCKWASHER, 5/16"	22	22
30	059022	CAP SCREW, HH, 5/16" - 18 x 3/4"	6	6
31	065015	NUT, Hex, 5/16" - 18	16	16
32	059003	CAP SCREW, HH, 5/16" - 18 x 1"	4	4
33	059135	CAP SCREW, HH, 5/16" x 18 x 3/4" Grade 5	4	4
34	059004	CAP SCREW, HH, 3/8" - 16 x 1"	8	8
35	061042	SCREW, Machine, 5/16" - 18 x 3/4"	4	4
36	062011	BOLT, Carriage, 5/16" - 18 x 3/4"	2	2
37	69094	J-CLAMP	1	1

REAR WHEELS & AXLE, BELT & DRIVE-HYDROSTATIC

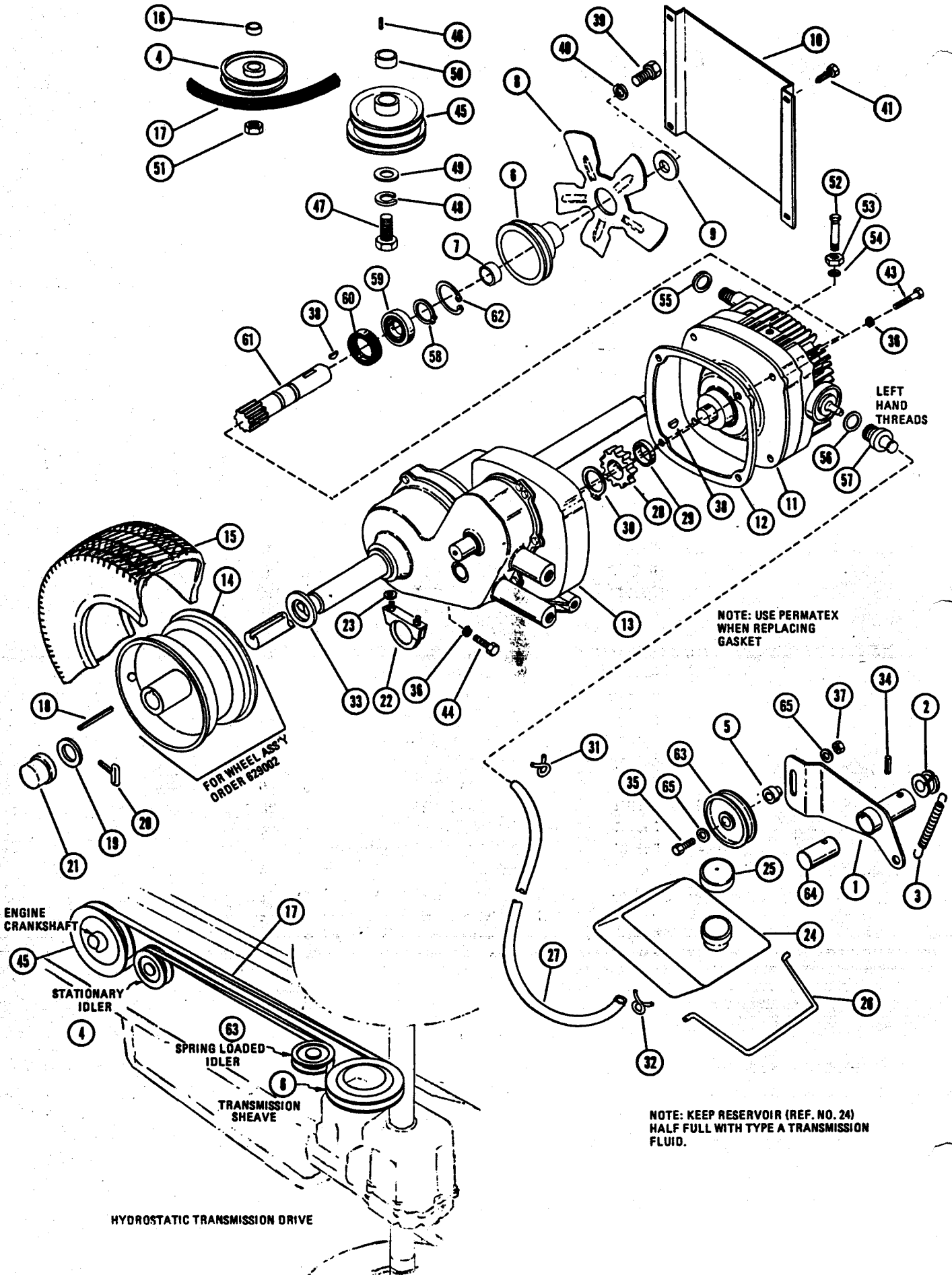

REAR WHEELS & AXLE, BELT & DRIVE-HYDROSTATIC

REF NO.	PART NO.	DESCRIPTION	929002
1	029265	IDLER ARM	1
2	055077	BEARING, Nylon	2
3	083111	SPRING	1
4	073054	IDLER	1
5	010360	SPACER	1
6	029041	SHEAVE	1
7	029142	SPACER	1
8	029043	FAN	1
9	064099	WASHER, Special	1
10	029042	SHIELD	1
† 11	629010	DRIVE ASS'Y HYDROSTATIC	1
12	029044	GASKET	1
*13		TRANSMISSION (Tecumseh No. 1309)	1
	629002	WHEEL ASS'Y, Rear Consists of:	2
14		071102 RIM	1
15		071101 TIRE, 20 x 8.00-10	1
16	029160	SPACER	1
17	072102	"V" BELT (Hydrostatic)	1
18	066018	KEY, Square, 1/4" x 1/4" x 1-3/4"	2
19	064029	WASHER, Special	2
20	067027	COTTER, "T" Head	2
21	029173	CAP, Grease	2
22	023077	"U" BOLT & CLAMP ASS'Y	2
23	064002	WASHER, Flat, 5/16"	2
24	029045	RESERVOIR, Oil	1
25	029001	CAP	1
26	029138	CLIP	1
27	029135	HOSE	1
28	029046	SPUR GEAR	1

*The transmission is to be serviced and warrantied by Tecumseh Products.

† Assembly includes Ref. No. 52 thru 62

REF NO.	PART NO.	DESCRIPTION	929002
29	029143	SPACER	1
30	057061	RING, Retaining	1
31	057052	CLAMP, Spring	1
32	069096	CLAMP, Spring	1
33	064110	WASHER	2
34	058016	ROLL PIN, 3/16" x 1"	1
35	059140	CAPSCREW, H.H. 5/16" - 18 x 1-1/2 Grade 5	1
36	063021	LOCKWASHER, 3/8"	6
37	065042	LOCKNUT, 5/16" - 18	1
38	066006	KEY, Woodruff, No. 3	2
39	059132	CAP SCREW, HH, 1/4" - 20 x 1	1
40	063002	LOCKWASHER, 1/4"	1
41	070009	FLANGE WHIZ LOCK SCREW	4
43	059141	CAP SCREW, HH, 3/8" - 16 x 3" Grade 5	4
44	059023	CAP SCREW, HH 3/8" - 16 x 3/4"	2
45	029105	SHEAVE	1
46	066026	KEY, Square, 1/4" x 1/4" x 2-1/2"	1
47	059142	CAP SCREW, HH, 7/16" - 20 x 1"	1
48	063005	LOCKWASHER, 7/16"	1
49	064047	WASHER, Special	1
50	029139	SPACER	1
51	065039	LOCKNUT, 3/8" - 16	1
52	029217	DUMP VALVE	1
53	029215	NUT, W/Gasket	1
54	056078	"O" RING	1
55	056079	OIL SEAL	1
56	029216	GASKET	1
57	029214	ADAPTOR	1
58	057072	SNAP RING	1
59	054071	BEARING	1
60	056095	SEAL	1
61	529014	INPUT SHAFT W/BEARING & SNAP RING	1
62	054071	SNAP RING	1
63	012132	IDLER	1
64	029264	PIVOT PIN	1
65	064123	WASHER	2

REAR WHEELS & AXLE, BELT & DRIVE -GEAR

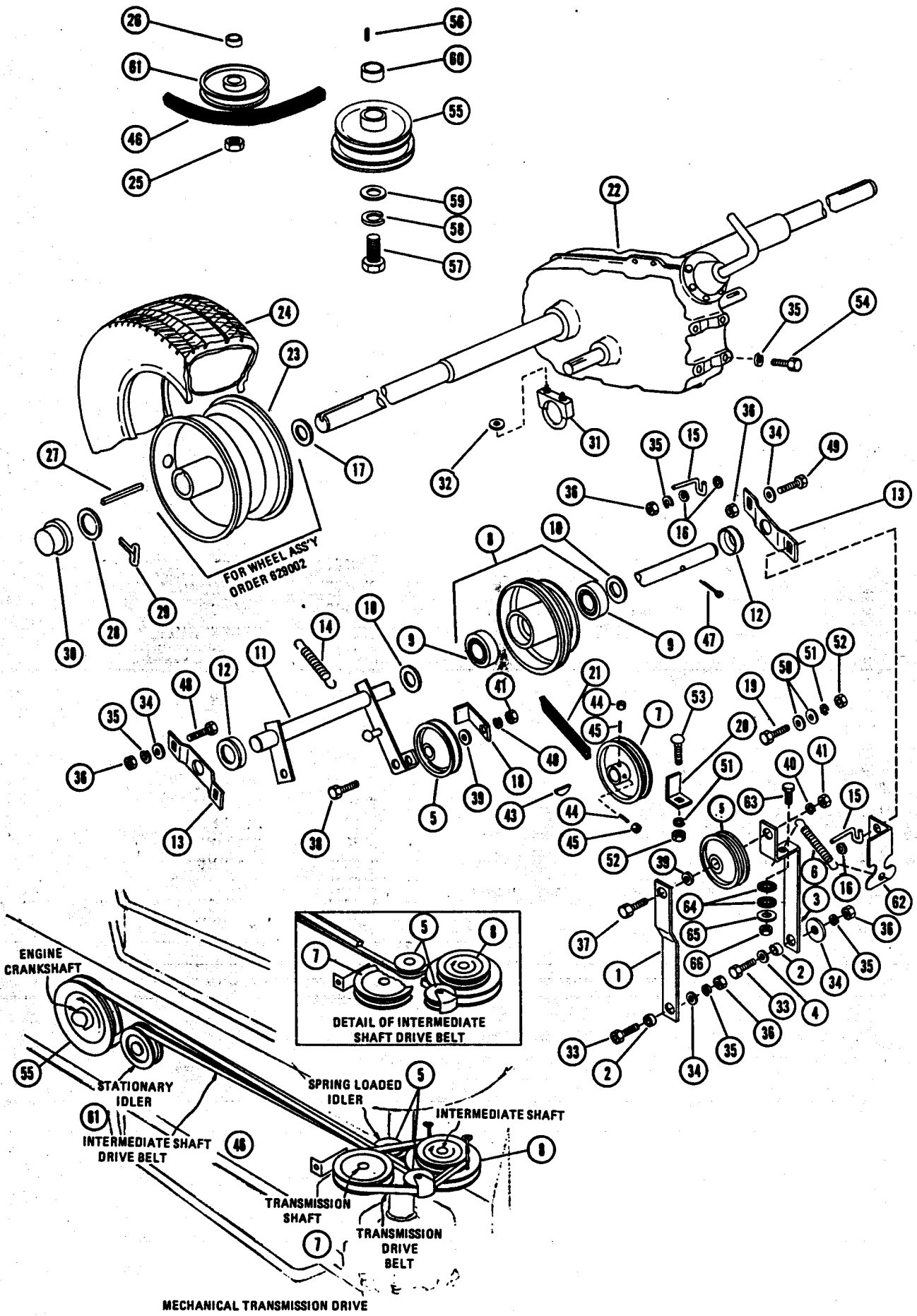

REAR WHEELS & AXLE, BELT & DRIVE -GEAR

REF NO.	PART NO.	DESCRIPTION	929001	REF NO.	PART NO.	DESCRIPTION	929001
1	029028	IDLER ARM	1	33	059005	CAP SCREW, HH, 3/8" - 16 x 1-1/4"	2
2	029140	SPACER	2	34	064008	WASHER, Flat, 3/8"	6
3	029029	IDLER ARM	1	35	063021	LOCKWASHER, 3/8"	8
4	064101	WASHER, Special	1	36	065018	NUT, Hex, 3/8" - 16	8
5	073101	IDLER	2	37	059143	CAP SCREW, HH, 1/2" x 2-1/4" Gr. 5	1
6	083110	SPRING	1	38	059058	CAP SCREW, HH, 1/2" - 13 x 3-1/4"	1
7	073064	SHEAVE	1			Grade 5	
8	629003	SHEAVE W/Ball Bearing	1	39	064120	WASHER, Flat, 1/2"	2
9	054073	BALL BEARING	2	40	063006	LOCKWASHER, 1/2"	2
10	064108	SPACER, Washer	3 (AR)	41	065021	NUT, Hex, 1/2" - 13	2
11	029034	IDLER PIVOT	1	43	066003	KEY, Woodruff, No. 9	1
12	055077	BEARING, Nylon	2	44	060030	SCREW, Hex Socket, 1/4" - 20 x 5/8"	2
13	029035	SUPPORT	2	45	065099	NUT, Hex Jam, 1/4" - 20	2
14	083117	SPRING	1	46	072103	"V" BELT	1
15	029039	BELT GUIDE	2	47	067006	PIN, Cotter, 3/16" x 1-1/4"	1
16	064102	WASHER, Special	4	48	059004	CAP SCREW, 3/8" - 16 x 1"	2
17	064110	WASHER	2	49	059158	BOLT, Tap, 3/8" - 16 x 1-3/4"	2
18	029036	BELT GUIDE	1	50	064002	WASHER, Flat, 5/16"	2
19	059022	CAP SCREW, HH, 5/16" - 18 x 3/4"	1	51	063003	LOCKWASHER, 5/16"	2
20	029031	STRAP	1	52	065015	NUT, Hex, 5/16" - 18	2
21	072100	"V" BELT	1	53	062011	BOLT, Carriage, 5/16" - 18 x 3/4"	1
22		TRANSAXLE Tecumseh No. 1212	1	54	059023	CAP SCREW, HH, 3/8" - 16 x 3/4"	2
	629002	WHEEL ASS'Y, Rear, Consists of		55	029105	SHEAVE	1
23		071102 RIM	1	56	066026	KEY, Square, 1/4" x 1/4" x 2-1/2"	1
24		071101 TIRE, 20 x 8.00 - 10	1	57	059142	CAP SCREW, HH, 7-1/16" - 20 UNF	
25	065039	LOCKNUT, 3/8" - 16	1			x 1"	1
26	029160	SPACER	1	58	063005	LOCKWASHER, 7/16"	1
27	066018	KEY, Square, 1/4" x 1/4" x 1-3/4"	2	59	064047	WASHER, Special	1
28	064029	WASHER, Special	2	60	029139	SPACER	1
29	067027	COTTER, "T" Head	2	61	073054	IDLER	1
30	029173	CAP, Grease	2	62	029263	BRACKET	1
31	023077	CLAMP ASS'Y	2	63	059069	CAPSCREW 5/16" - 18 x 1-1/4	1
32	064002	WASHER, Flat, 5/16"	2	64	075026	GROMMET	2
				65	064007	WASHER	1
				66	065042	LOCKNUT 5/16" - 18	1

*The Transaxle is to be serviced and warranted by Tecumseh Products

SHIFT CONTROL & LINKAGE -HYDROSTATIC

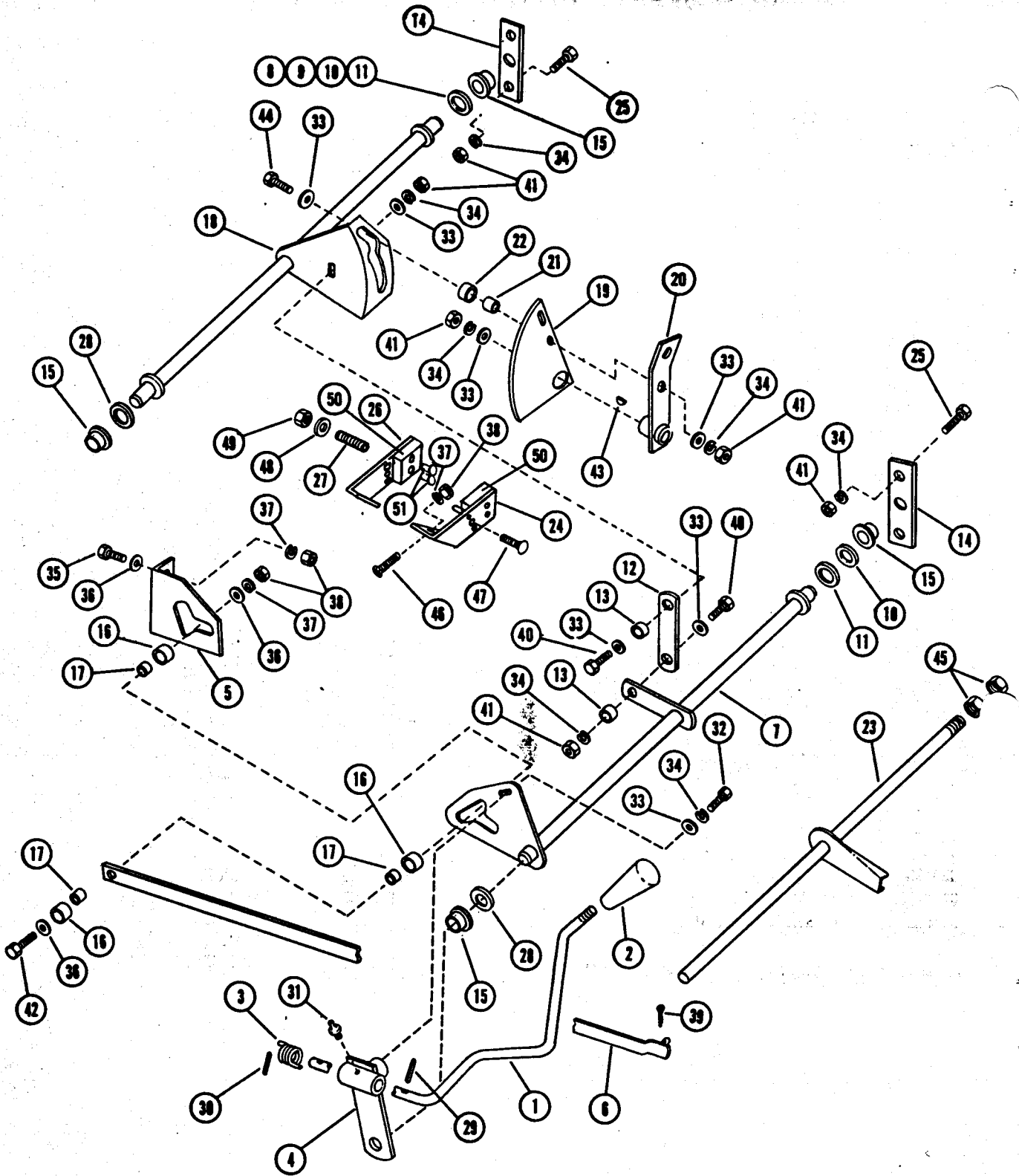

SHIFT CONTROL & LINKAGE -HYDROSTATIC

REF NO.	PART NO.	DESCRIPTION	929002	REF NO.	PART NO.	DESCRIPTION	929002
1	029061	SHIFT LEVER	1	28	064009	WASHER, Flat, 3/4"	2
2	075049	HANDLE	1	29	058019	PIN, Grooved, 3/16" x 1 Type E	1
3	083112	SPRING, Tension	1	30	058049	PIN, Grooved, 3/16" x 1-1/4"	1
4	029055	PIVOT ASS'Y	1			Type E	1
5	029062	BRACKET	1	31	022093	FITTING, Grease, 1/4" - 28	1
6	029057	LINK	1	32	059023	CAP SCREW, HH, 3/8" - 16 x 3/4"	1
7	029053	NEUTRALIZER	1	33	064008	WASHER, Flat, 3/8"	7
8	064117	SHIM, 005 Thick	2	34	063021	LOCKWASHER, 3/8"	9
9	064118	SHIM, 010 Thick	1	35	059003	CAP SCREW, HH, 5/16" - 18 x 1"	2
10	064119	SHIM, 025 Thick	(AR 4)	36	064002	WASHER, Flat, 5/16"	4
11	064108	SHIM, Washer	(AR)	37	063003	LOCKWASHER, 5/16"	5
12	029064	ARM	1	38	065015	NUT, Hex, 5/16" - 18	5
13	029159	SPACER	2	39	067024	PIN, Cotter, 1/8" x 3/4"	1
14	029056	PLATE	2	40	059005	CAP SCREW, HH, 3/8" - 16 x 1-1/4"	2
15	055080	BUSHING	4	41	065018	NUT, Hex, 3/8" - 16	8
16	029066	ROLLER	3	42	059073	CAP SCREW, HH, 5/16" - 18 x 1-3/4"	1
17	029065	SPACER	3				1
18	029052	CAM	1	43	066006	KEY, Woodruff, No. 3	1
19	029063	PLATE	1	44	059027	CAP SCREW, HH, 3/8" - 16 x 1-3/4"	1
20	029060	LEVER	1				1
21	029160	WASHER, Spacer	1	45	065039	LOCKNUT, Hex, 3/8" - 16	2
22	029068	SPACER	1	46	062011	BOLT, Carriage, 5/16" - 18 x 1-3/4"	2
23	029054	LEVER	1				2
24	629033	FRONT DRAG BRKT. w/Lining	1	47	062030	BOLT, Carriage, 1/4" - 20 x 3-1/2"	1
25	059004	CAP SCREW, HH, 3/8" - 16 x 1"	4	48	064007	WASHER, Flat, 1/4"	1
26	629032	REAR DRAG BRKT. w/Lining	1	49	065070	LOCKNUT, Hex, 1/4" - 20	1
27	083115	SPRING	1	50	029220	LINING	2
				51	068053	RIVET	4

SHIFT CONTROL & LINKAGE - GEAR

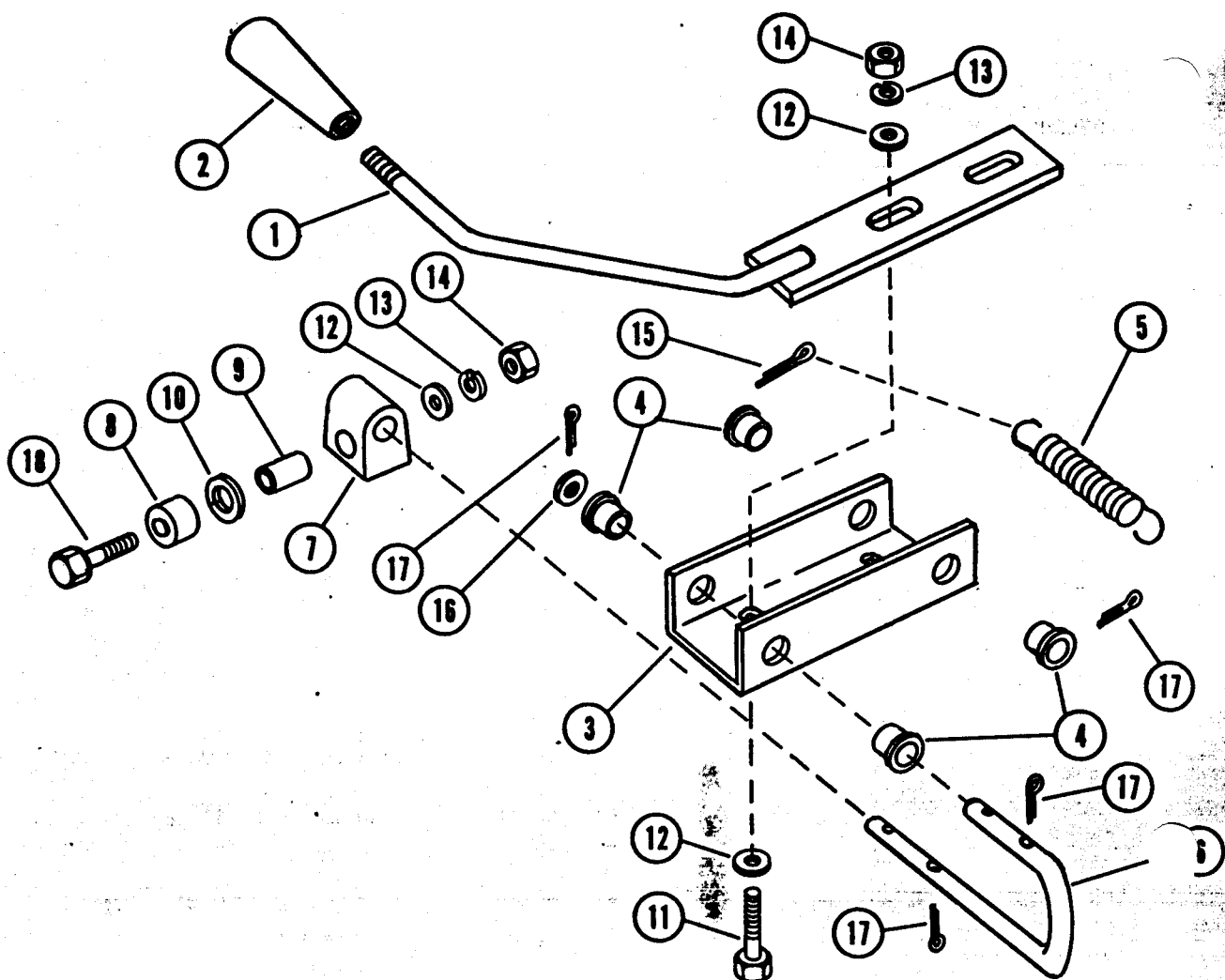

REF NO.	PART NO.	DESCRIPTION	929001
1	029047	LEVER ASSEMBLY	1
2	075049	HANDLE	1
3	029048	CHANNEL	1
4	055078	BUSHING, Nylon	4
5	083116	SPRING	1
6	029049	ROD	1
7	029050	PIVOT	1
8	029051	SPACER	1
9	029025	SPACER, Bushing	1
10	064104	WASHER, Special	1
11	059003	CAP SCREW, HH, 5/16" - 18 x 1"	2
12	064002	WASHER, Flat, 5/16"	5
13	063003	LOCKWASHER, 5/16"	3
14	065015	NUT, Hex, 5/16" - 18	3
15	067021	PIN, Cotter, 1/8" x 1-1/2"	1
16	064121	WASHER, Flat, 7/16"	6
17	067004	PIN, Cotter, 1/8" x 1"	5
18	059074	CAP SCREW, HH, 5/16" - 18 x 2-3/4"	1

BRAKE & PARKING BRAKE

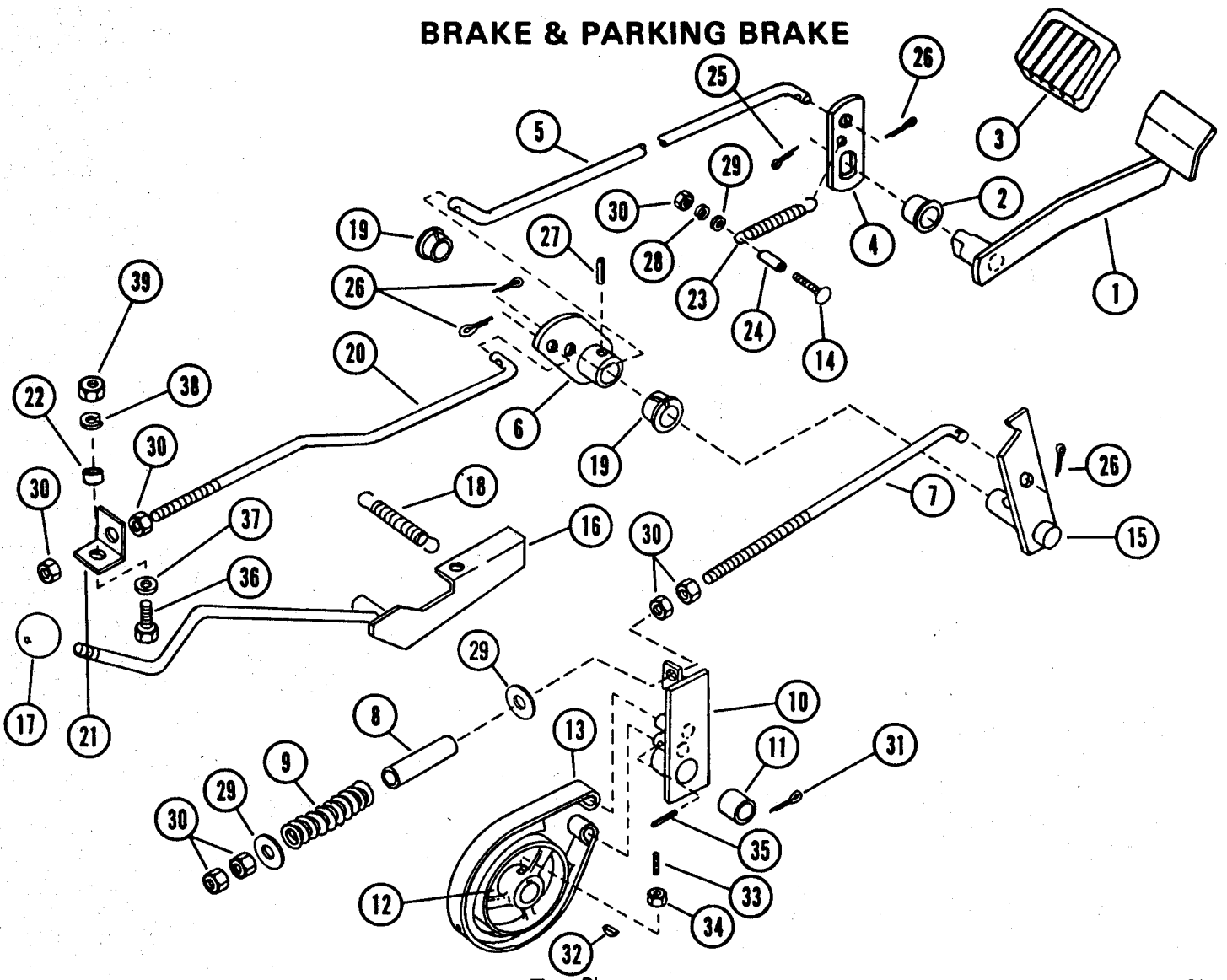

REF NO.	PART NO.	DESCRIPTION			REF NO.	PART NO.	DESCRIPTION		
			929001	929002				929001	929002
1	029067	BRAKE PEDAL	1	1	22	055089	BUSHING	1	
2	055081	BEARING, Nylon	1	1	23	083117	SPRING	1	1
3	075051	PAD, Pedal	1	1	24	029144	SPACER BUSHING	1	1
4	029081	ARM	1	1	25	067021	PIN, cotter, 1/8" x 1-1/2"	1	1
5	029076	ROD	1	1	26	067024	PIN, Cotter, 1/8" x 3/4"	4	3
6	029069	ARM	1	1	27	058049	PIN, Grooved, 3/16" x 1-1/4" Type E	1	1
7	029078	BRAKE ROD	1	1	28	063003	LOCKWASHER, 5/16"	1	1
8	029079	SPACER	1	1	29	064002	WASHER, Flat, 5/16"	2	2
9	083113	SPRING, Compression	1	1	30	065015	NUT, Hex, 5/16" - 18	7	5
10	029070	BRAKE PIVOT (Gear)	1		31	067002	PIN, Cotter, 3/32" x 1"	1	1
	029071	BRAKE PIVOT (Hydrostatic)		1	32	066003	KEY, Woodruff, No. 9	1	1
11	055024	BUSHING	1	1	33	060030	SCREW, Hex Socket, 1/4" - 20 x 5/8"	1	1
12	029037	BRAKE DRUM	1	1	34	065099	NUT, Hex Jam, 1/4" - 20	1	1
13	29252	BRAKE BAND, W/Lining	1	1	35	058019	PIN, Grooved, 3/16" x 1" Type E	2	2
14	062023	BOLT, Carriage 5/16" - 18 x 1-1/2"	1	1	36	059005	CAP SCREW, 3/8" - 16 x 1-1/4"	1	1
15	029072	ARM	1	1	37	064008	WASHER, Flat, 3/8"	1	
16	029073	BRAKE LOCK	1	1	38	063021	LOCKWASHER, 3/8"	1	
17	075052	KNOB	1	1	39	065018	NUT, Hex, 3/8" - 16	1	
18	083109	SPRING	1	1					
19	055077	BEARING, Nylon	2	2					
20	029077	ROD	1						
21	029080	ANGLE	1						

PTO LINKAGE, BELT & SHEAVE

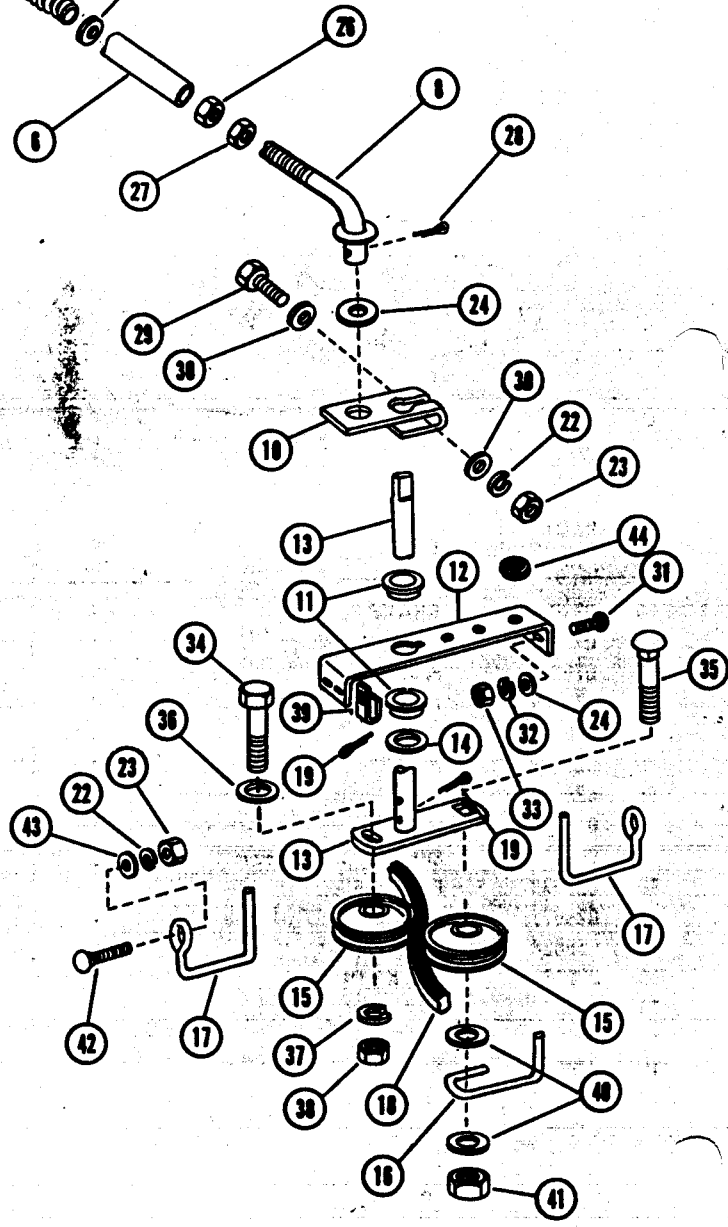
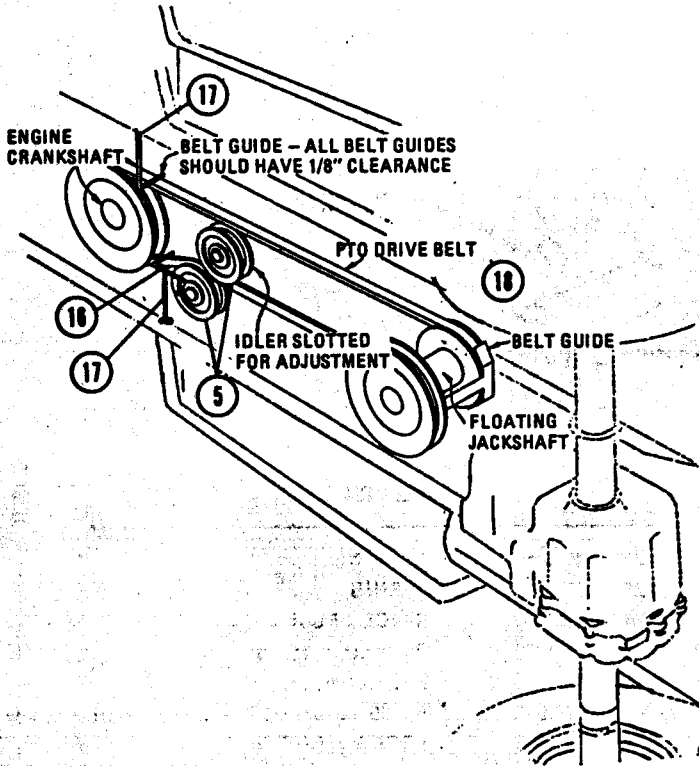
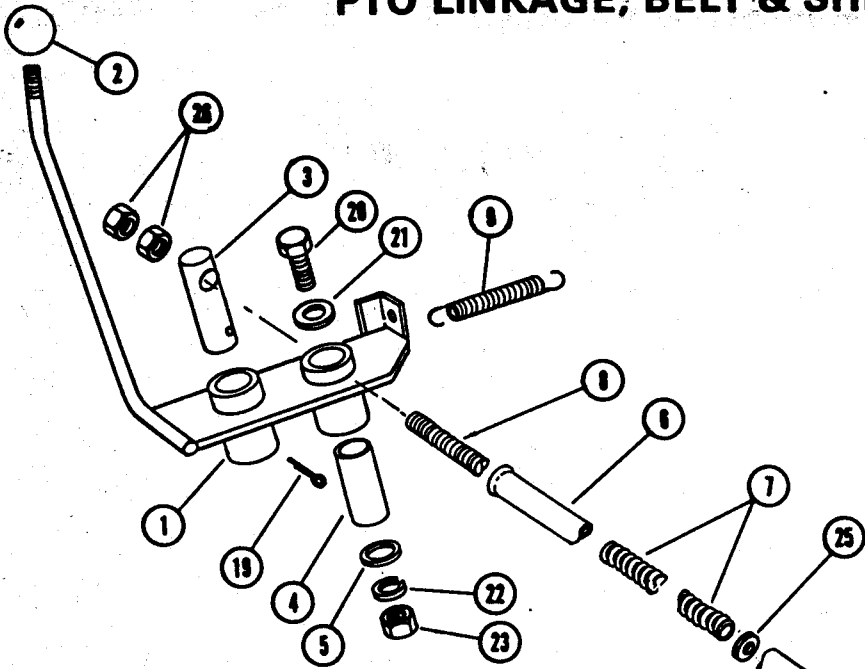

PTO LINKAGE, BELT & SHEAVE

REF NO.	PART NO.	DESCRIPTION	929001	929002
1	029098	HANDLE	1	1
2	075052	KNOB	1	1
3	029104	PIN	1	1
4	029103	SPACER	1	1
5	064105	WASHER, Special	1	1
6	029102	GUIDE TUBE	1	1
7	083114	SPRING	1	1
8	029097	ROD	1	1
9	083118	SPRING	1	1
10	029101	CLEVIS	1	1
11	055084	BUSHING	2	2
12	029100	SUPPORT	1	1
13	029099	IDLER PIVOT	1	1
14	064100	WASHER, Special	1	1
15	073101	IDLER	2	2
16	029136	BELT FINGER	1	1
17	029137	BELT FINGER	2	2
18	072101	"V" BELT	1	1
19	067004	PIN, Cotter, 1/8" x 1"	3	3
20	059149	CAP SCREW, HH, 3/8" - 16 x 2-1/4" Grade 5	1	1
21	064008	WASHER, Flat, 3/8"	1	1
22	063021	LOCKWASHER, 3/8"	4	4
23	065018	NUT, Hex, 3/8" - 16	4	4
24	064007	WASHER, Flat, 1/4"	5	5
25	064002	WASHER, Flat, 5/16"	1	1
26	065015	NUT, Hex, 5/16" - 18	3	3
27	065061	NUT, Hex Jam, 5/16" - 18	1	1
28	067016	PIN, Cotter, 5/32" x 1"	1	1
29	059068	CAP SCREW, HH, 3/8" - 16 x 2"	1	1
30	64043	WASHER, Flat, 3/8"	2	2
31	062012	BOLT, Carriage, 1/4" - 20 x 3/4"	4	4
32	063002	LOCKWASHER, 1/4"	4	4
33	065032	NUT, Hex, 1/4" - 20	4	4
34	059041	CAP SCREW, HH, 1/2" - 13 x 2-1/4"	1	1
35	062006	BOLT, Carriage, 1/2" - 13 x 2-1/2"	1	1
36	064120	WASHER, Flat, 1/2"	1	1
37	063006	LOCKWASHER, 1/2"	1	1
38	065021	NUT, Hex, 1/2"	1	1
39	064094	J-CLAMP	1	1
40	064047	WASHER, Flat, 1/2"	2	2
41	065097	LOCKNUT, Hex, 1/2" - 13	1	1
42	062029	BOLT, Carriage, 3/8" - 16 x 1"	2	2
43	064102	WASHER, Special	2	2
44	075055	GROMMET	1	1

HAND LIFT & SHEAVE

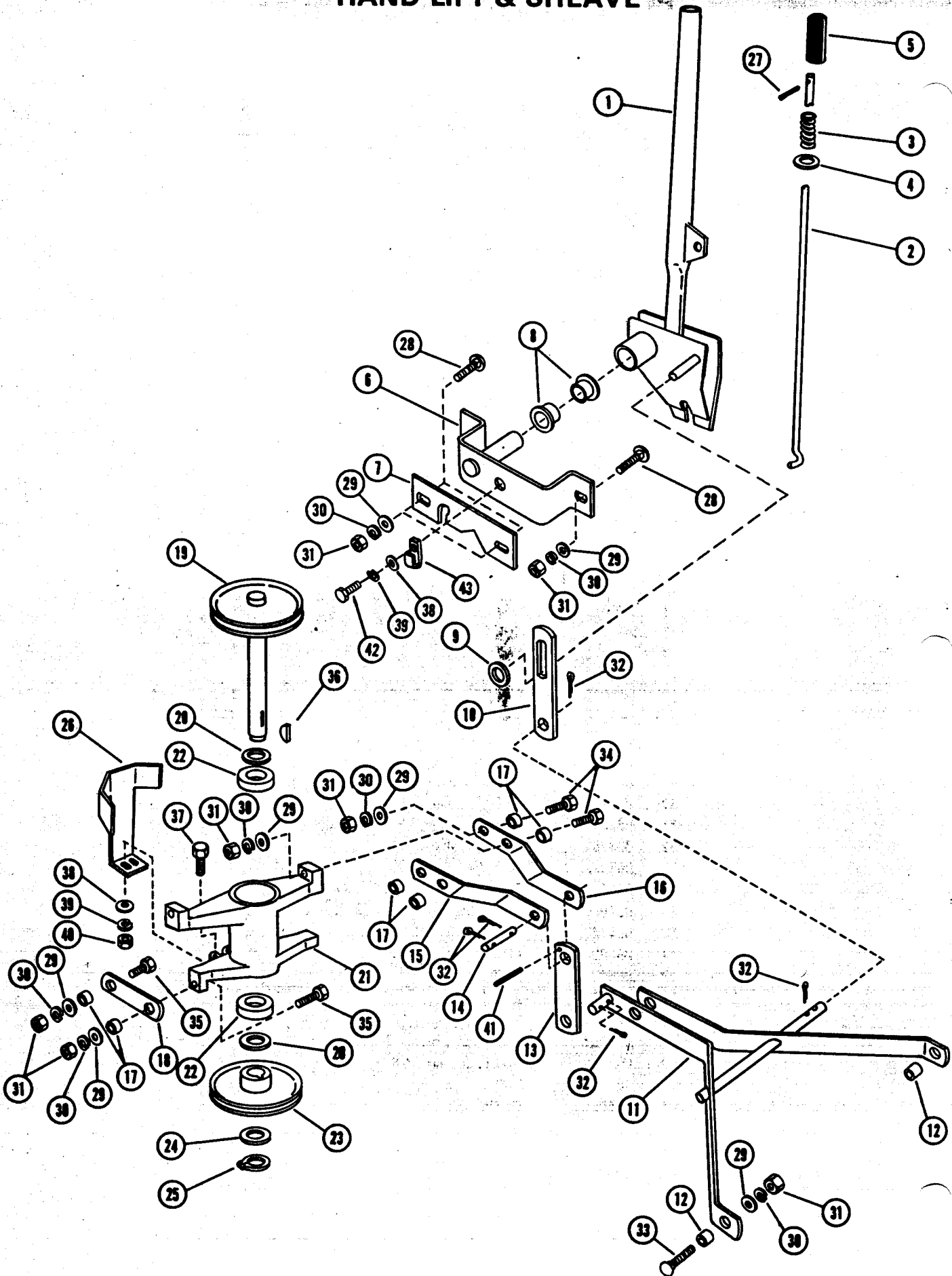

HAND LIFT & SHEAVE

REF NO.	PART NO.	DESCRIPTION	929001	929002
1	029082	LIFT LEVER	1	1
2	029083	ROD	1	1
3	083104	SPRING	1	1
4	064096	WASHER, Special	1	1
5	075053	GRIP	1	1
6	029084	BRACKET	1	1
7	029090	LIFT PLATE	1	1
8	055082	BUSHING, Nylon	2	2
9	064097	WASHER, Special	1	1
10	029091	STRIP	1	1
11	029088	LIFT	1	1
12	029141	SPACER	2	2
13	029092	LINK	1	1
14	029096	PIN	1	1
15	029093	LINK, R.H.	1	1
16	029094	LINK, L.H.	1	1
17	55089	BUSHING	8	8
18	029095	LINK	2	2
19	029085	SHEAVE	1	1
20	64088	WASHER	2	2
21	029089	BEARING HOUSING	1	1
22	054073	BALL BEARING	2	2
23	029086	SHEAVE, PTO	1	1
24	064108	WASHER, Special	(AR)	(AR)
25	057012	SNAP RING	1	1
26	029087	BELT GUIDE	1	1
27	058034	ROLL PIN, 1/8" x 3/4"	1	1
28	062029	BOLT, Carriage 3/8" - 16 x 1"	4	4
29	064008	WASHER, Flat, 3/8"	14	14
30	063021	LOCKWASHER, 3/8"	14	14
31	065018	NUT, Hex, 3/8" - 16	14	14
32	067004	PIN, Cotter, 1/8" x 1"	6	6
33	062016	BOLT, Carriage, 3/8" - 16 x 1-1/4"	2	2
34	059004	CAP SCREW, HH, 3/8" - 16 x 1"	4	4
35	059005	CAP SCREW, HH, 3/8" x 16 x 1-1/4"	4	4
36	066003	KEY, Woodruff, No. 9	1	1
37	059003	CAP SCREW, HH, 5/16" - 18 x 1"	2	2
38	064002	WASHER, Flat, 5/16"	3	3
39	063003	LOCKWASHER, 5/16"	3	3
40	065015	NUT, Hex, 5/16" - 18	2	2
41	058050	PIN, Groove, 1/4" x 1-1/4" Type E	1	1
42	059039	CAPSCREW 5/16" - 18 x 1/2	1	1
43	069094	J-CLAMP	1	1

DASH, DASH CONTROLS & ELECTRICAL

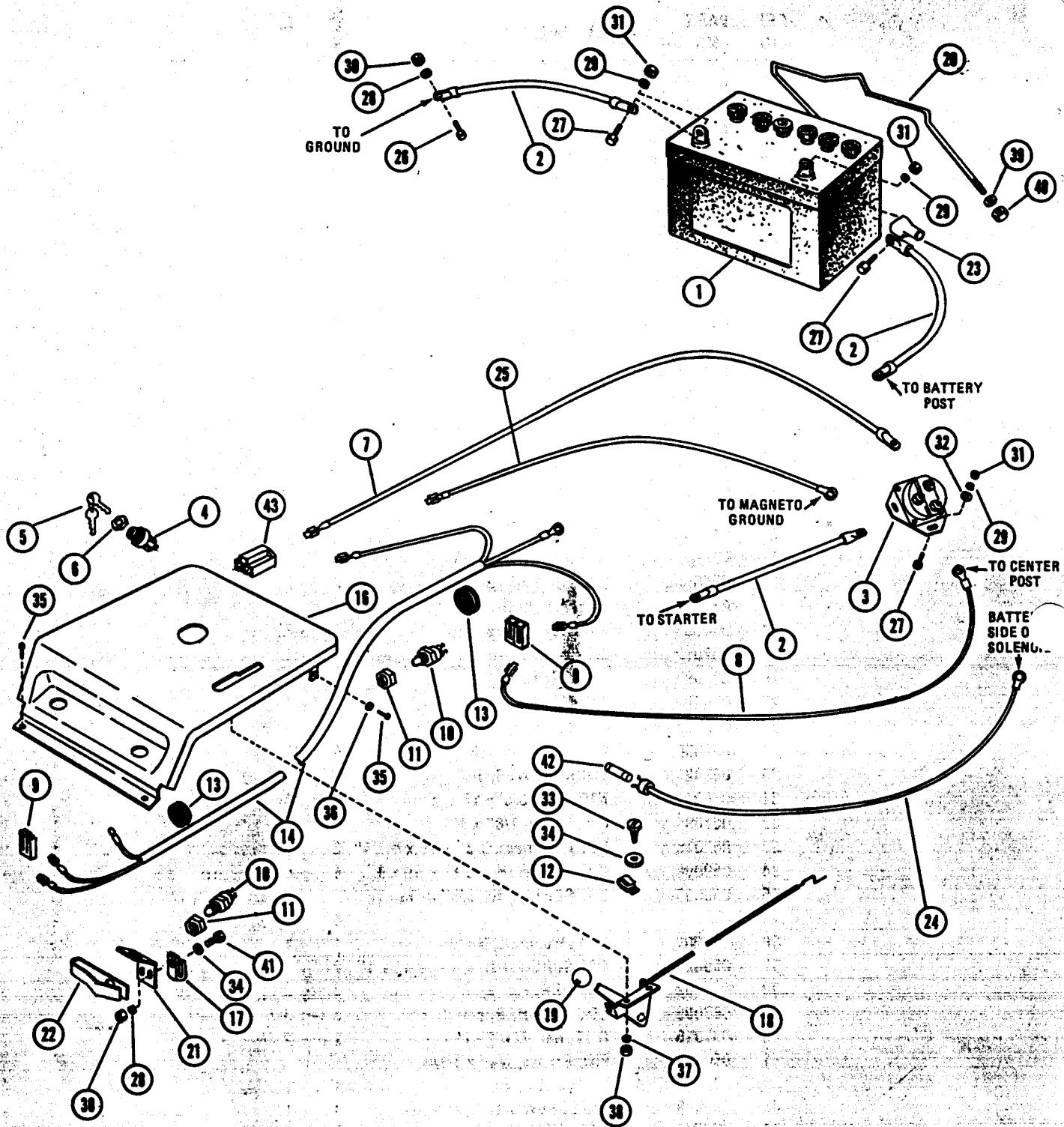

DASH, DASH CONTROLS & ELECTRICAL

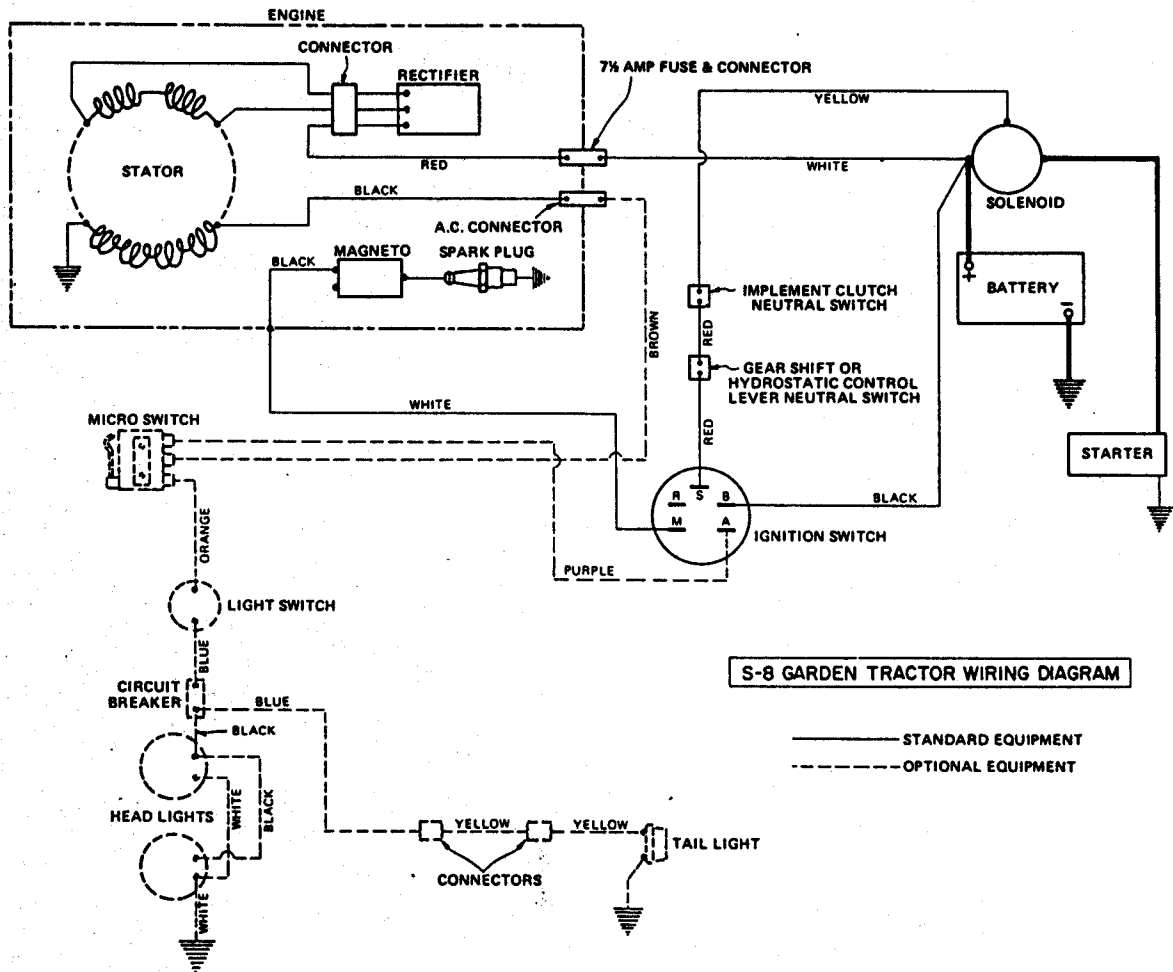

REF NO.	PART NO.	DESCRIPTION	929001	929002	REF NO.	PART NO.	DESCRIPTION	929001	929002
1	029175	BATTERY, 12 Volt	1	1	23	075057	INSULATOR	1	1
2	029026	CABLE	3	3	24	029164	WIRE	1	1
3	029132	SOLENOID	1	1	25	029168	WIRE 14" long, White	1	1
4	029149	SWITCH, Ignition	1	1	26	059022	CAP SCREW, 5/16" - 18 x 3/4"	1	1
5	013157	KEY SET	1	1	27	059001	CAP SCREW, HH, 1/4" - 20 x 3/4"	4	4
6	065106	NUT, Special, 9/16" - 24	1	1	28	063003	LOCKWASHER, 5/16"	3	1
7	029167	WIRE ASS'Y, 29" long Black	1	1	29	063002	LOCKWASHER, 1/4"	4	4
8	029169	WIRE ASS'Y, 24" long, Yellow	1	1	30	065015	NUT, Hex, 5/16" - 18	3	1
9	029170	CONNECTOR HOUSING, 2 Wire	2	2	31	065032	NUT, Hex, 1/4" - 20	4	4
10	029131	SWITCH, Safety	2	2	32	064007	WASHER, Flat, 1/4"	2	2
11	065096	NUT, Special, 9/16" - 18 UNF	2	2	33	074040	SCREW, Self Tapping 5/16" x 1/2"	1	1
12	069094	CLIP	1	1	34	064002	WASHER, Flat, 5/16"	3	1
13	075055	GROMMET	2	2	35	074043	SCREW, Self Tapping, RH, 10 - 29 x 1/2"	5	5
14	029166	WIRE HARNESS (Mechanical)	1		36	064001	WASHER, 3/16" Wrought	2	2
15	029165	WIRE HARNESS (Hydrostatic)		1	37	063011	LOCKWASHER, No. 10	2	2
16	529003	DASH W/Decal	1	1	38	065055	NUT, Hex, No. 10 - 24	2	2
17	069094	J CLAMP	1		39	064123	WASHER, Flat, 5/16"	2	2
18	069095	THROTTLE CONTROL	1	1	40	065095	LOCKNUT, Hex, 5/16" - 18	2	2
19	075019	KNOB	1	1	41	059003	CAP SCREW, HH, 5/16" - 18 x 1"	2	
20	029128	ROD, Battery Hold Down	1	1	42	013198	FUSE	1	1
21	029129	BRACKET, Safety Sw.	1		43	023478	CONNECTOR HOUSING	1	1
22	029130	ACTUATOR, Safety Sw.	1						

ROTARY MOWER - 36RM - 829001

SERIAL NUMBER 000301 AND UP

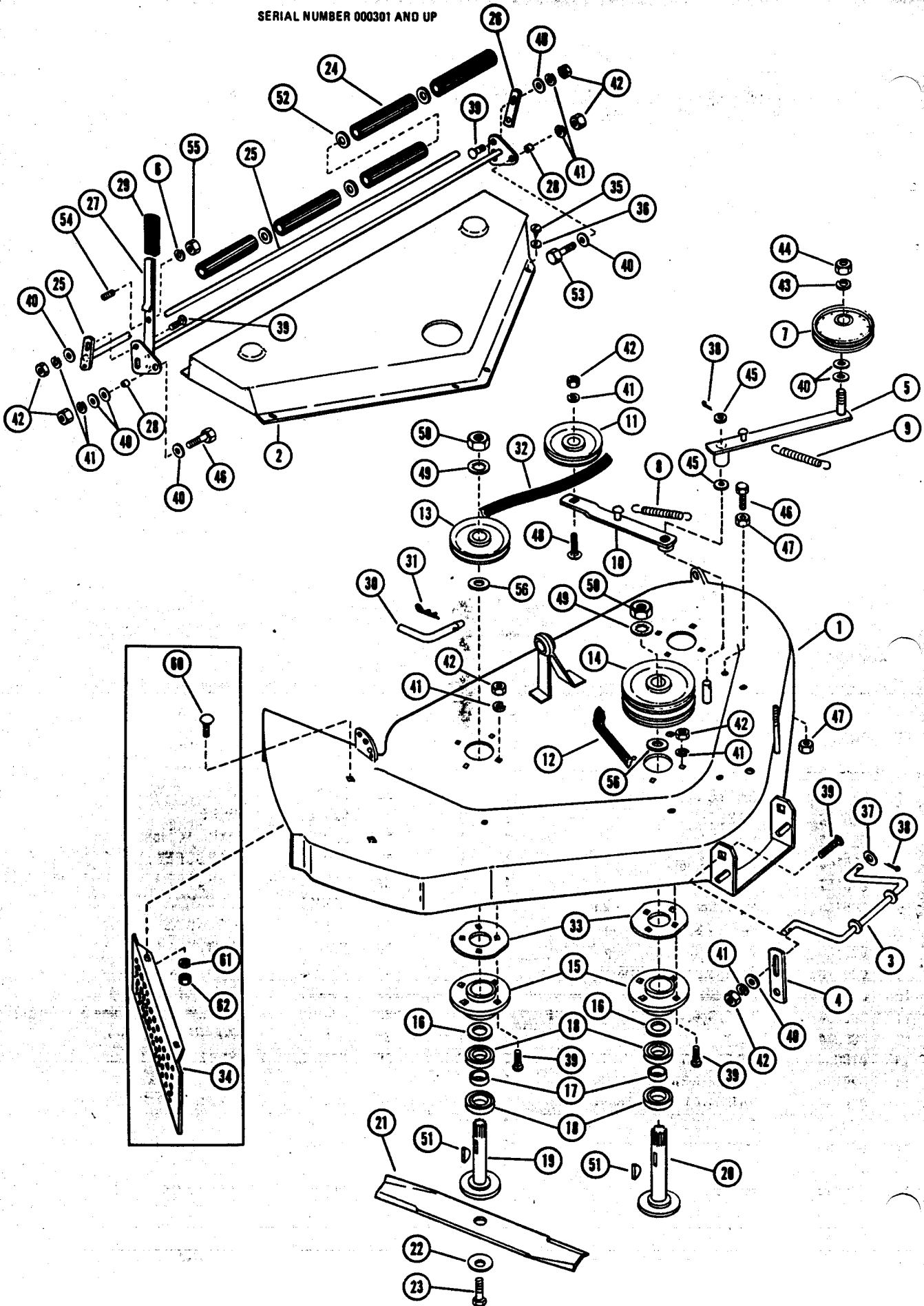

ROTARY MOWER - 36RM - 829001

SERIAL NUMBER 000301 AND UP

REF NO.	PART NO.	DESCRIPTION	REF NO.	PART NO.	DESCRIPTION		
1	529004	MOWER DECK, 36"	1	33	029177	SHIM	9 (AR)
2	029146	SHIELD	1	* 34	729004	MULCHER KIT	
3	029153	SUPPORT	1	35	074046	SCREW, Self Tapping H.H. 1/4" x 1/2"	6
4	029176	LINK	2	36	064007	WASHER, Flat, 1/4"	6
5	029152	IDLER ARM	1	37	064039	WASHER, Special	2
6	063011	LOCKWASHER, No. 10	1	38	067004	PIN, Cotter, 1/8" x 1"	3
7	073059	IDLER	1	39	062029	BOLT, Carriage, 3/8" - 16 x 1"	16
8	083117	SPRING	1	40	064008	WASHER, Flat, 3/8"	10
9	083127	SPRING	1	41	063021	LOCKWASHER, 3/8"	19
10	029151	IDLER ARM	1	42	065018	NUT, Hex, 3/8" - 16	19
11	073054	IDLER	1	43	063006	LOCKWASHER, 1/2"	1
12	072077	"V" BELT	1	44	065021	NUT, Hex, 1/2" - 13	1
13	073053	SHEAVE	2	45	064003	WASHER, Flat, 1/2"	2
14	029154	SHEAVE	1	46	059005	CAP SCREW, H.H. 3/8" - 16 x 1-1/4"	2
15	031044	FLANGE	3	47	065001	NUT, Hex, Jam, 3/8" - 16	2
16	064048	WASHER, Special	3 (AR)	48	062016	BOLT, Carriage, 3/8" - 16 x 1-1/4"	1
17	031144	SPACER, Split (445 Thick)	3	49	063027	LOCKWASHER, Int, Tooth 3/4"	3
18	054120	BEARING, Ball	6	50	065016	NUT, Hex, Jam, 3/4" - 16 UNF	3
19	029156	SHAFT, Outside	2	51	066003	KEY, Woodruff, No. 9	3
20	029155	SHAFT, Center	1	52	064140	WASHER, Flat, 5/8"	4
21	029157	BLADE	3	53	059004	CAP SCREW, HH. 3/8" - 16 x 1"	1
22	031191	WASHER, Special	3	54	059156	CAP SCREW, Socket Hd. No. 10-24 x 3/8"	1
23	059153	CAP SCREW, Hex 7/16" - 20 x 1" UNF Gr. 5	3	55	065055	NUT, Hex, No. 10 - 24	1
24	031141	ROLLER	5	56	064108	WASHER	6
25	029150	SHAFT	1				
26	031156	LINK	1				
27	629019	ADJUSTER, Roller	1				
28	055089	BUSHING	2				
29	075069	GRIP	1				
30	029178	PIN	1				
31	067029	HAIRPIN COTTER	1				
32	072078	"V" BELT	1				

*Mulcher Kit Consists of Mulcher Plate and the Following Hardware:

60	062035	BOLT CARRIAGE, 3/8" x 3/4"	2
61	063021	LOCKWASHER, 3/8"	2
62	065018	NUT, Hex, 3/8" - 16	2

MUFFLER, FUEL LINES & TANK

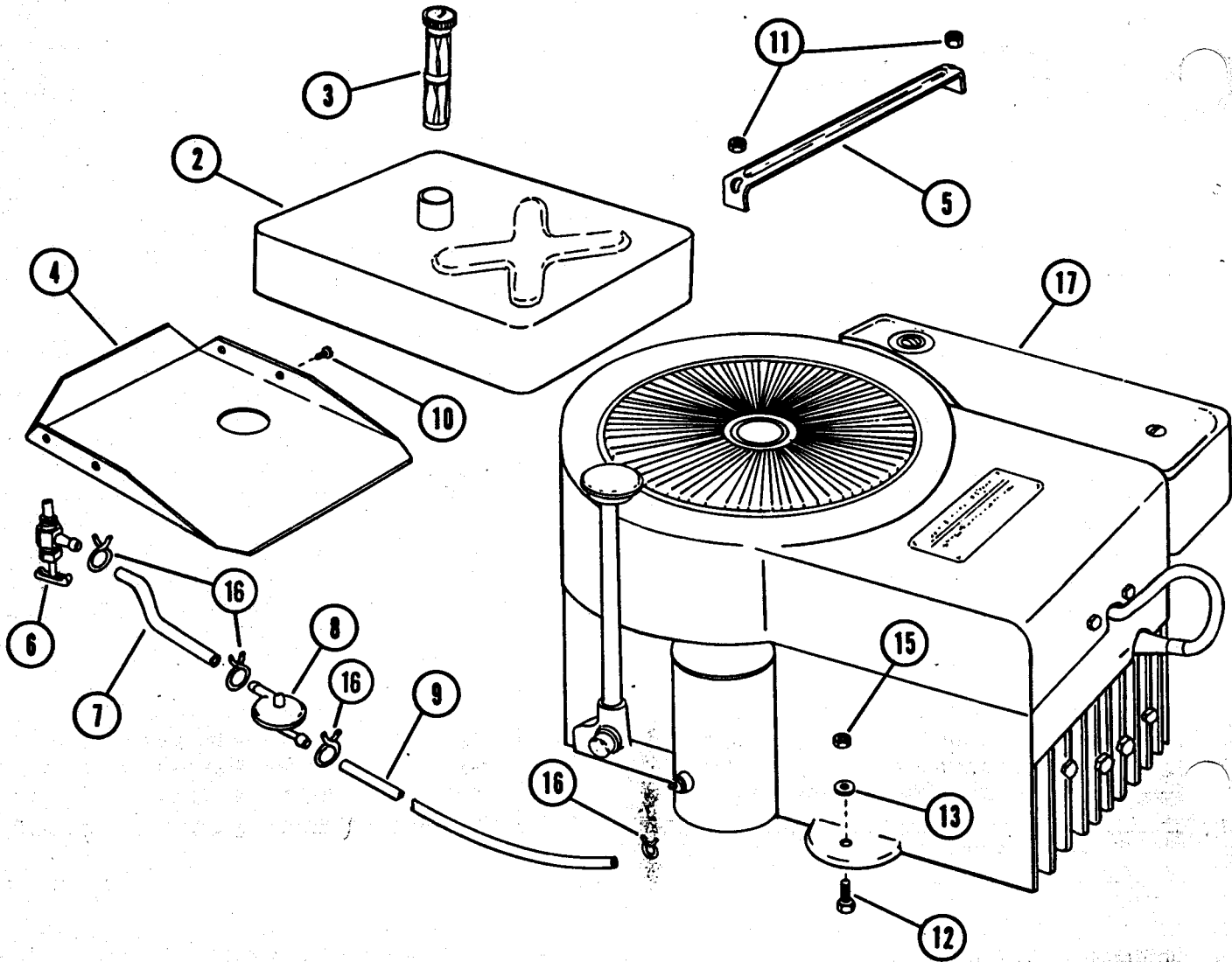

REF NO.	PART NO.	DESCRIPTION	929001	929002
2	029162	FUEL TANK	1	1
3	029110	GUAGE	1	1
4	029114	BRACE	1	1
5	029115	STRAP	1	1
6	031536	VALVE, Shut-Off	1	1
7	029113	HOSE, 4" long, 1/4" ID	1	1
8	029108	FUEL FILTER	1	1
9	029112	HOSE, 8-3/4" long, 1/4" ID	1	1
10	070009	FLANGE WHIZLOCK SCREW	4	4
11	065070	LOCKNUT, Hex, 1/4" - 20	2	2
12	059140	CAP SCREW, HH, 5/16" - 18		
		x 1-1/2" Grade 5	4	4
13	064123	WASHER, Flat, 5/16"	4	4
15	065124	NUT, Hex, 5/16" - 18 Grade C	4	4
16	029172	CLIP	4	4
17		ENGINE BRIGGS *191707 Type	1	1

0636 Order Replacement Engine
and or Engine Replacement Parts
From Respective Engine Manufacturer.

DEALER SET UP AND PRE-SERVICE INSTRUCTIONS

ASSEMBLY

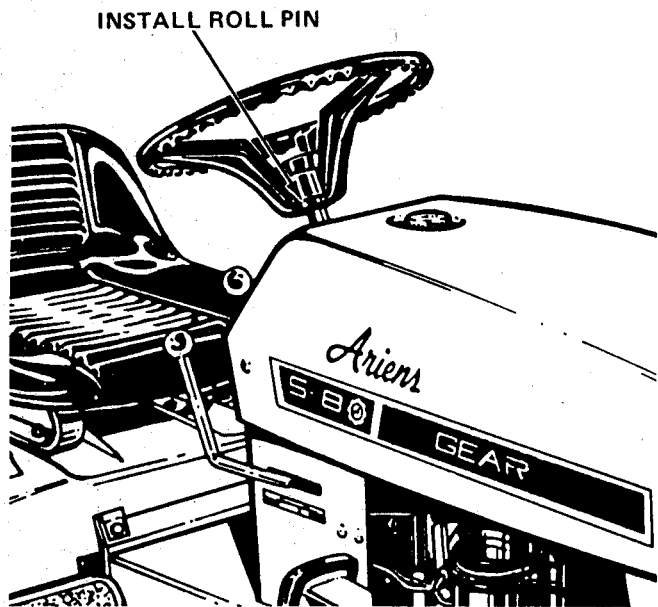

Figure 42

STEERING WHEEL

Install the steering wheel on the column and secure with a roll pin as shown in Figure 42.

SERVICE BATTERY

Remove the battery from the tractor. This will prevent any accidentally spilled electrolyte from damaging the tractor.

Electrolyte is not furnished with the tractor. Use only battery grade sulphuric acid electrolyte with 1.265 specific gravity plus or minus 0.005 corrected to 80° F.

Prepare battery as follows:

1. Remove vent plugs.

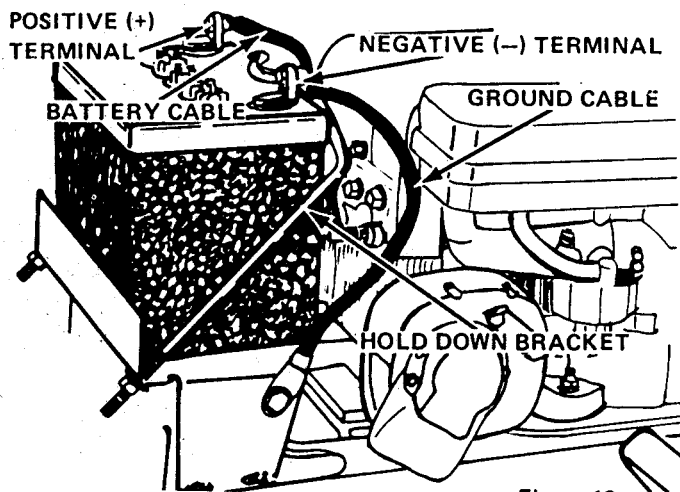

Figure 43

2. With battery removed from the tractor, fill each cell with electrolyte until electrolyte level rises to split ring at the bottom of the filler tube. DO NOT OVERFILL.



BE CAREFUL! ELECTROLYTE CONTAINS SULPHURIC ACID WHICH IS HARMFUL TO SKIN, EYES AND CLOTHING. HANDLE WITH EXTREME CARE. IF SPILLAGE OCCURS ON BODY OR CLOTHING, RINSE AT ONCE WITH WATER.

3. After filling cells, wait five to ten minutes and add additional electrolyte if necessary to bring electrolyte to proper level.
4. Charge battery with a 12 volt charger for 30 minutes at 4 to 6. amps.
5. After charging, add electrolyte until the level is up to the split ring in the filler tube. Thereafter, add only clean, distilled water as use and time requires.
6. Replace vent caps. Clean and dry battery exterior.

INSTALL BATTERY

Place the battery in the battery carrier as shown in Figure 43 with the positive (+) terminal to the right side of the tractor.

Secure the battery in place with the battery hold down as shown in Figure 43. Do not overtighten the hold-down nuts.

Attach the battery cable to the positive (+) terminal and the ground cable to the negative (-) terminal as shown in Figure 43. Tighten the cables to the terminals securely.

Coat the terminals and the battery cable ends with a light coat of grease or petroleum jelly to prevent corrosion.

ENGINE OIL

Fill the engine crankcase (Figure 44). Use Ariens Gard-N-Yard MS 10W-30 oil when using lawn and garden attachments, use Ariens Sno-Thro oil (SAE 5W - 20 MS classification) when using snow removal attachments.

Do not overfill - the oil level must never exceed the full mark.

TRANSMISSION OIL LEVEL (gear shift model 929001)

Check the oil level using the following procedure:

1. Place tractor on a level surface.
2. Raise rear deck to gain access to the transmission check level plug.
3. Remove check plug, Figure 45. Oil should seep out of the check plug hole. If the level is too low, remove the filler

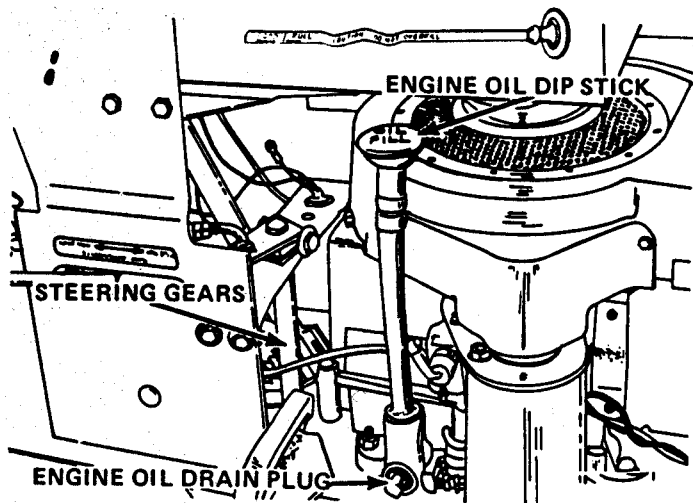

Figure 44

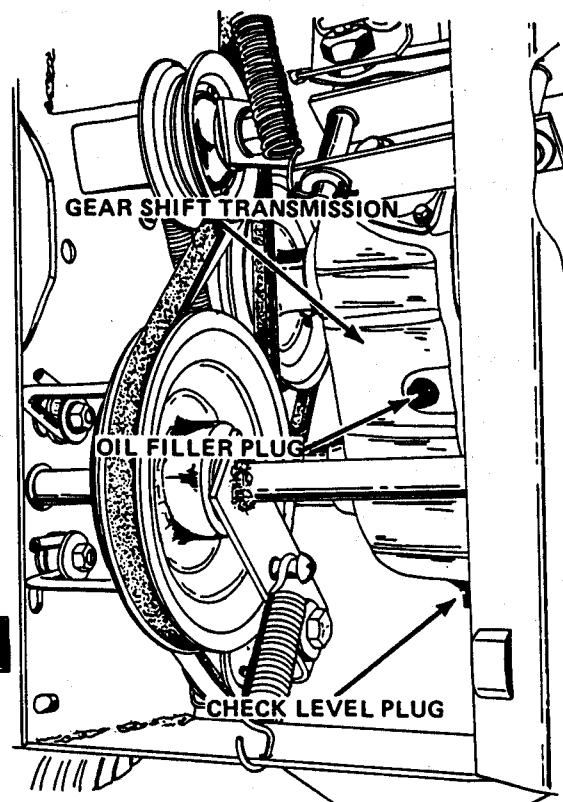

Figure 45

plug and add Ariens MP-90 Premium Gear Lube (SAE 90-EP) weight transmission oil until the level is correct.

4. Replace both the filler and the check plugs.

CAUTION: THE HYDROSTATIC TRANSMISSION AND THE DIFFERENTIAL ASSEMBLIES HAVE SEPARATE OIL RESERVOIRS. TYPE A TRANSMISSION FLUID MUST BE USED IN THE HYDROSTATIC TRANSMISSION AND ARIENS MP 90 PREMIUM GEAR LUBE (SAE 90-EP) MUST BE USED IN THE DIFFERENTIAL. IF IMPROPER OIL IS USED IN EITHER RESERVOIR, SERIOUS DAMAGE COULD OCCUR.



TRANSMISSION OIL LEVEL (hydrostatic models)

Check hydrostatic oil level using the following procedure:

1. Place tractor on a level surface.
2. Raise the rear deck and remove the oil filler cap shown in Figure 46.

CAUTION: THE AREA AROUND THE FILLER CAP MUST BE CLEAN BEFORE REMOVING THE CAP. DO NOT ALLOW ANY DIRT OR FOREIGN MATERIAL TO ENTER THE EXPANSION RESERVOIR.



3. Check oil level. The expansion reservoir should be $\frac{1}{2}$ full at ambient temperature. If required, add type A transmission fluid UNTIL THE RESERVOIR IS $\frac{1}{2}$ FULL.

CAUTION: If overfilled, the oil will expand during operation and may leak out around the filler cap.



If oil cannot be seen in the expansion reservoir, it will be necessary to fill the reservoir to the proper level and bleed (remove air) from the transmission. See Owner's manual for this procedure.

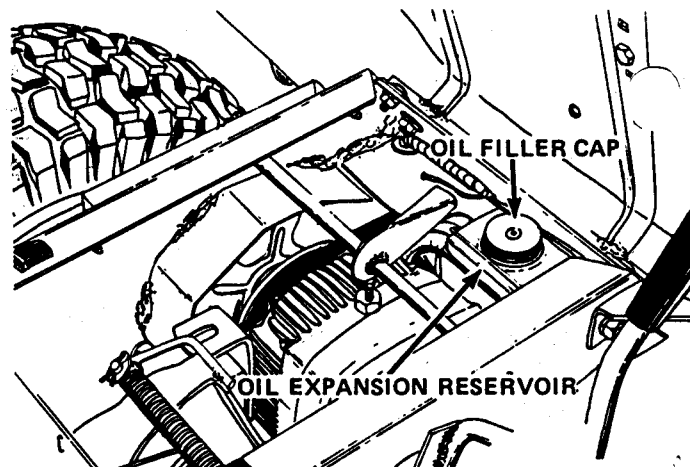

Figure 46

DIFFERENTIAL OIL LEVEL (hydrostatic models)

Check the differential oil level on hydrostatic tractors using the following procedure:

1. Place tractor on a level surface.
2. Remove the oil level and filler plug from the rear of the transmission, Figure 47.
3. Oil should reach the level and filler plug hole. If it does not, add Ariens Premium Gear Lube MP-90 (SAE 90-EP) until the proper level is reached.

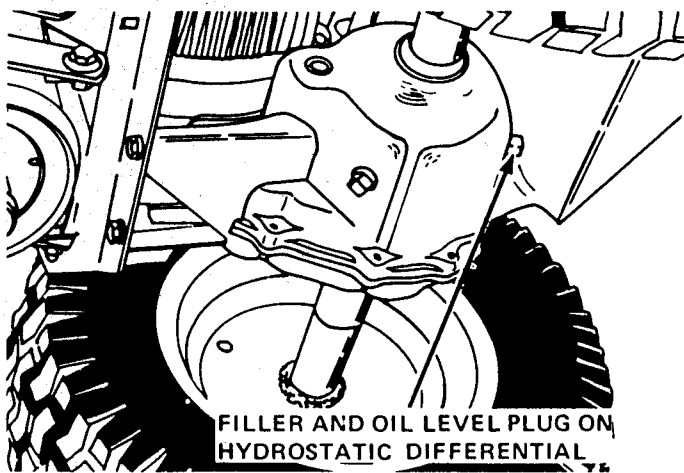

Figure 47

FILL FUEL TANK

Fill fuel tank with clean, fresh, regular grade gasoline. Do not use premium gasoline.

ADJUST TIRE PRESSURE

Tires are over-inflated for shipping purposes. Correct tire pressures are essential for proper handling or attachment performance. Adjust tire pressures as shown in the chart. Use a low pressure gauge for accurate readings.

DESCRIPTION	LAWN WORK	SNOW THROWER AND FRONT BLADE WORK
Front tires (15 x 6.00-6)	10	12
Rear tires (20 x 8.00-10)	6	6

ASSEMBLE MOWER

1. Remove shipping straps from front support bar and belt idler.

ATTACH MOWER TO THE TRACTOR

Use the following procedure to attach the mower to the tractor:

1. Remove ignition key. Place implement power clutch lever in the disengaged position and engage the tractor brake lock.

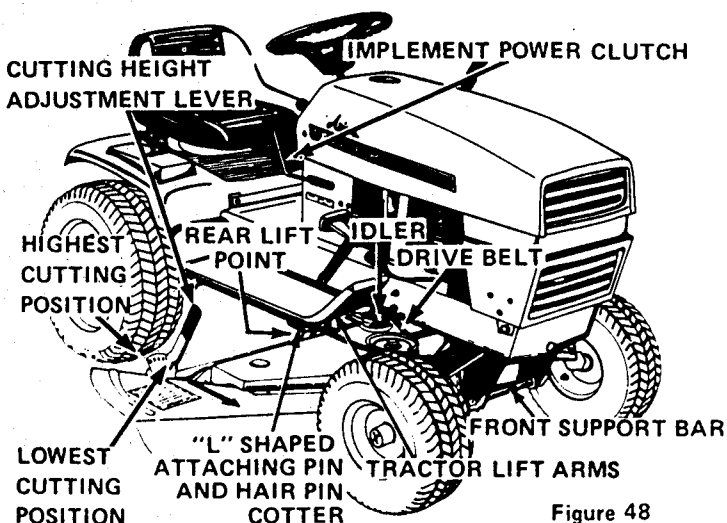

Figure 48

2. Raise the tractor attachment lift lever.
3. Place cutting height adjustment lever in the second lowest cutting position as shown in Figure 48.
4. Raise front support bar to clear the front tractor tire and slide the mower under the tractor from the right side.
5. Place the drive belt over the rear lift point and lower the attachment lift lever. Align ball joint of rear lift point to tractor lift arms and secure with the "L" shape attaching pin and hairpin cotter provided. See Figure 48.
6. Position drive belt over the drive and driven sheaves and place idler to the inside of the belt as shown in Figure 48.
7. Position front support bar in the tractor saddle brackets and secure with the locks and latches as shown in Figure 49.

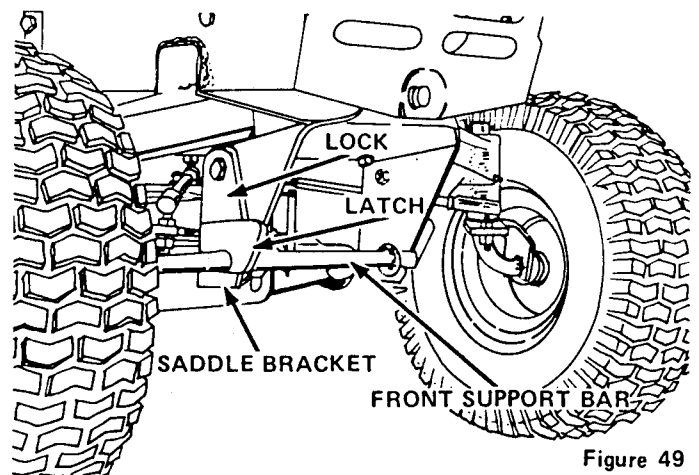

Figure 49

ADJUST BLADE LEVEL AND PITCH

IMPORTANT: ADJUST MOWER BLADE LEVEL AND PITCH AS OUTLINED IN THE OWNER'S MANUAL.

DELIVERY

Using the Owner's Manual as a guide, instruct the customer as follows:

1. Instruct the customer on the operation of the tractor. Emphasize safety and discuss the safety information in the Owner's Manual.
2. Advise customer to change oil in the engine crankcase after the first five hours of operation.
3. Advise customer to change the transmission oil filter after the first five hours operation.
4. Explain how to perform the recommended lubrication and periodic service.
5. Explain maintenance and adjustment instructions.
6. Demonstrate how to mount and dismount attachments.
7. Make certain the customer has his Owner's Manual.
8. Explain Ariens Warranty Policy. Fill out and return Ariens Warranty Registration Card.