

# BUNN®

## *TDS-3S*

## *TDS-5S*

## *ICD-3S*

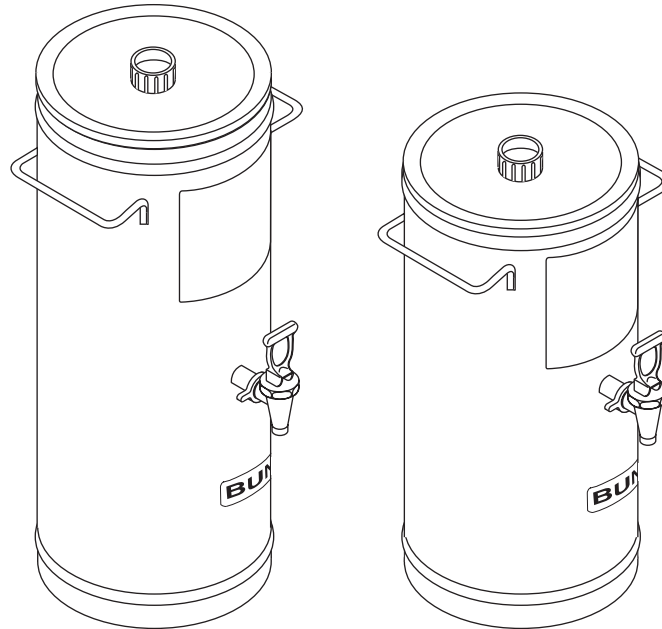

## USE & CARE INFORMATION

### INTRODUCTION

These dispensers are designed to hold and serve either a three or five gallon batch of iced tea or iced coffee, depending on the model. When proper precautions are followed, tea/coffee may be brewed directly into the dispenser and then transported to a remote serving location. The dispenser must be placed on a sturdy counter or shelf.

**NOTICE** - In order to use this dispenser with a Bunn-O-Matic brewer, the guide rails on the base of the brewer will need to be removed, to allow for the width of the TDS-S/ICD-S dispenser. To retain the guide rails on the machine, order BUNN Guide Rail Extension Kit number 32033.0000.

**NOTE** - The TDS-3S & ICD-3S dispensers weigh approximately 40 pounds when full. The TDS-5S weighs approximately 55 pounds when full. **You must be careful when lifting these dispensers. WHEN THE DISPENSER IS HOLDING LIQUID, LIFT THE DISPENSER USING THE HANDLES ONLY. DO NOT LIFT THE DISPENSER FROM THE BOTTOM.**

### BUNN-O-MATIC CORPORATION

POST OFFICE BOX 3227

SPRINGFIELD, ILLINOIS 62708-3227

PHONE: (217) 529-6601 FAX: (217) 529-6644

## DAILY CLEANING

### CAUTION - CLEAN AND SANITIZE YOUR DISPENSER **DAILY**

1. Thoroughly clean the inner surfaces of the dispenser using a mild cleaner/sanitizer and water solution then thoroughly rinse the dispenser with warm water.

**NOTE** - Bunn-O-Matic recommends the use of KAY-5® for this purpose. (Kay-5 is a product of the Kay Chemical Company, Greensboro, NC) Simply pour the cleaner/sanitizer into an empty dispenser. Run a complete brew cycle *of just water* into the dispenser and let it set for a minute. Empty the dispenser and thoroughly rinse with warm water.

2. Remove the faucet handle/stem assembly by unscrewing the faucet bonnet just beneath the faucet handle. Use the enclosed cleaning brush to thoroughly clean the inside of the faucet and the faucet shank from inside the dispenser.

3. Disassemble the faucet/stem assembly. The faucet cleaning procedure requires a 3-compartment sink. Thoroughly wash all faucet parts in a mild detergent and water solution in the first sink. Rinse the parts in hot water in the second sink. Sanitize the parts for one minute in 75°F warm chlorine solution (at least 50 ppm) in the third sink. Do **NOT** use full-strength bleach, but a solution with water, of no more than 50 ppm of chlorine. Reassemble the faucet and attach it to the dispenser.

4. Wash the entire outside surface of the dispenser with a clean damp cloth.

### CAUTION - **NEVER** KEEP BREWED ICED BEVERAGES OVERNIGHT

## REPLACEMENT PARTS

### TDS-5S DISPENSERS

1.	03043.0002	Decal, Fresh Brewed Tea
2.	00651.0000	Decal, Bunn
3.	33843.0000	Decal, Cleaning & Sanitizing
4.	00674.0000	Faucet Cleaning Brush
5.	33829.0000	Lid, Molded
6.	03093.0002	Faucet Wing Nut
7.	01221.0000	C-Ring, Faucet Shank
8.	03260.0001	Faucet Assy (Includes items 9 thru 13)
9.	29163.0001	Faucet Handle, Black
10.	00601.0000	Faucet Spring
11.	00600.0000	Faucet Seat Cup
12.	29164.0000	Faucet Stem
13.	29165.0001	Faucet Bonnet, Black
14.	29166.0001	Faucet Repair Kit (Includes items 9 thru 12)

### TDS-3S & ICD-3S DISPENSERS

1.	03043.0002	Decal, Fresh Brewed Tea
2.	21412.0001	Decal, Fresh Brewed Iced Coffee
3.	00651.0000	Decal, Bunn
4.	33843.0000	Decal, Cleaning & Sanitizing
5.	00674.0000	Faucet Cleaning Brush
6.	33829.0000	Lid, Molded
7.	03093.0002	Faucet Wing Nut
8.	01221.0000	C-Ring, Faucet Shank
9.	03260.0001	Faucet Assy (Includes items 10 thru 14)
10.	29163.0001	Faucet Handle, Black
11.	00601.0000	Faucet Spring
12.	00600.0000	Faucet Seat Cup
13.	29164.0000	Faucet Stem
14.	29165.0001	Faucet Bonnet, Black
15.	29166.0001	Faucet Repair Kit (Includes items 10 thru 13)

### Rail Extension Kit number 32033.0000

This kit allows for the widening of the guide rails on the brewer to accommodate the use of the TDS-S/ICD-S dispenser.

#### Contents:

QTY	PART NUMBER	DESCRIPTION
6	01533.0006	Spacer
6	01320.0000	Screw

#### Instructions:

1. Remove the guide rails attached to the base of the brewer.
2. Attach the guide rails using the spacers and the longer screws as pictured.

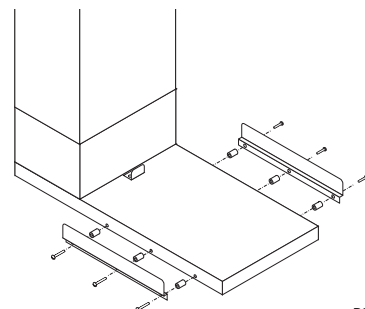

P2397

## WARRANTY

Bunn-O-Matic Corp. ("Bunn") warrants the equipment manufactured by it to be commercially free from defects in material and workmanship existing at the time of manufacture and appearing within one year from the date of installation. In addition:

1.) Bunn warrants electronic circuit and/or control boards to be commercially free from defects in material and workmanship for three years from the date of installation.

2.) Bunn warrants the compressor on refrigeration equipment to be commercially free from defects in material and workmanship for two years from the date of installation.

3.) Bunn warrants that the grinding burrs on coffee grinding equipment will grind coffee to meet original factory screen sieve analysis for three years from date of installation or for 30,000 pounds of coffee, whichever comes first.

This warranty does not apply to any equipment, component or part that was not manufactured by Bunn or that, in Bunn's judgement, has been affected by misuse, neglect, alteration, improper installation or operation, improper maintenance or repair, damage or casualty.

**THE FOREGOING WARRANTY IS EXCLUSIVE AND IS IN LIEU OF ANY OTHER WARRANTY, WRITTEN OR ORAL, EXPRESS OR IMPLIED, INCLUDING, BUT NOT LIMITED TO, ANY IMPLIED WARRANTY OF EITHER MERCHANTABILITY OR FITNESS FOR A PARTICULAR PURPOSE.** The agents, dealers or employees of Bunn are not authorized to make modifications to this warranty or to make additional warranties that are binding on Bunn. Accordingly, statements by such individuals, whether oral or written, do not constitute warranties and should not be relied upon.

The Buyer shall give Bunn prompt notice of any claim to be made under this warranty by telephone at (217) 529-6601 or by writing to Post Office Box 3227, Springfield, Illinois, 62708-3227. If requested by Bunn, the Buyer shall ship the defective equipment prepaid to an authorized Bunn service location. If Bunn determines, in its sole discretion, that the equipment does not conform to the warranty, Bunn shall repair the equipment with no charge for parts during the warranty period and no charge for labor by a Bunn Authorized Service Representative during the warranty period. If Bunn determines that repair is not feasible, Bunn shall, at its sole option, replace the equipment or refund the purchase price for the equipment.

**THE BUYER'S REMEDY AGAINST BUNN FOR THE BREACH OF ANY OBLIGATION ARISING OUT OF THE SALE OF THIS EQUIPMENT, WHETHER DERIVED FROM WARRANTY OR OTHERWISE, SHALL BE LIMITED, AS SPECIFIED HEREIN, TO REPAIR OR, AT BUNN'S SOLE OPTION, REPLACEMENT OR REFUND.**

In no event shall Bunn be liable for any other damage or loss, including, but not limited to, lost profits, lost sales, loss of use of equipment, claims of Buyer's customers, cost of capital, cost of down time, cost of substitute equipment, facilities or services, or any other special, incidental or consequential damages.