

# BUNN®

# *FCD-4*

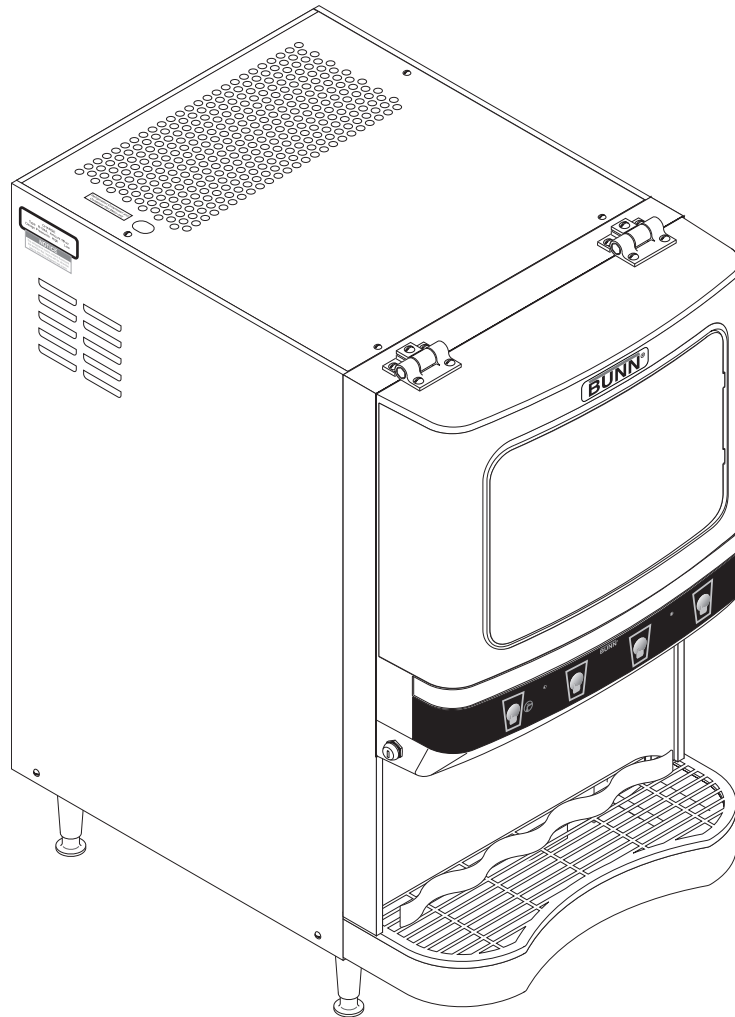

## INSTALLATION & OPERATING MANUAL

**BUNN-O-MATIC CORPORATION**

POST OFFICE BOX 3227

SPRINGFIELD, ILLINOIS 62708-3227

PHONE: (217) 529-6601 FAX: (217) 529-6644

## CONTENTS

Introduction & Warranty .....	2
User Notices .....	3
Initial Set-Up & Electrical Requirements .....	4
Plumbing Requirements .....	5
Operating Controls .....	6
Initial Fill .....	8
Dispenser Use .....	10
Cleaning .....	11
Adjustments & Optional Settings .....	13
Function Lists .....	18
Coolant Diagram .....	19
Schematic Wiring Diagram .....	20

## WARRANTY

Bunn-O-Matic Corp. (“Bunn”) warrants the equipment manufactured by it to be commercially free from defects in material and workmanship existing at the time of manufacture and appearing within one year from the date of installation. In addition:

1.) Bunn warrants electronic circuit and/or control boards to be commercially free from defects in material and workmanship for two years from the date of installation.

2.) Bunn warrants the compressor on refrigeration equipment to be commercially free from defects in material and workmanship for two years from the date of installation.

3.) Bunn warrants that the grinding burrs on coffee grinding equipment will grind coffee to meet original factory screen sieve analysis for three years from date of installation or for 30,000 pounds of coffee, whichever comes first.

This warranty does not apply to any equipment, component or part that was not manufactured by Bunn or that, in Bunn’s judgement, has been affected by misuse, neglect, alteration, improper installation or operation, improper maintenance or repair, damage or casualty.

**THE FOREGOING WARRANTY IS EXCLUSIVE AND IS IN LIEU OF ANY OTHER WARRANTY, WRITTEN OR ORAL, EXPRESS OR IMPLIED, INCLUDING, BUT NOT LIMITED TO, ANY IMPLIED WARRANTY OF EITHER MERCHANTABILITY OR FITNESS FOR A PARTICULAR PURPOSE.** The agents, dealers or employees of Bunn are not authorized to make modifications to this warranty or to make additional warranties that are binding on Bunn. Accordingly, statements by such individuals, whether oral or written, do not constitute warranties and should not be relied upon.

The Buyer shall give Bunn prompt notice of any claim to be made under this warranty by telephone at (217) 529-6601 or by writing to Post Office Box 3227, Springfield, Illinois, 62708-3227. If requested by Bunn, the Buyer shall ship the defective equipment prepaid to an authorized Bunn service location. If Bunn determines, in its sole discretion, that the equipment does not conform to the warranty, Bunn shall repair the equipment with no charge for parts during the warranty period and no charge for labor by a Bunn Authorized Service Representative during the warranty period. If Bunn determines that repair is not feasible, Bunn shall, at its sole option, replace the equipment or refund the purchase price for the equipment.

**THE BUYER’S REMEDY AGAINST BUNN FOR THE BREACH OF ANY OBLIGATION ARISING OUT OF THE SALE OF THIS EQUIPMENT, WHETHER DERIVED FROM WARRANTY OR OTHERWISE, SHALL BE LIMITED, AS SPECIFIED HEREIN, TO REPAIR OR, AT BUNN’S SOLE OPTION, REPLACEMENT OR REFUND.**

In no event shall Bunn be liable for any other damage or loss, including, but not limited to, lost profits, lost sales, loss of use of equipment, claims of Buyer’s customers, cost of capital, cost of down time, cost of substitute equipment, facilities or services, or any other special, incidental or consequential damages.

## USER NOTICES

Carefully read and follow all notices on the equipment and in this manual. They were written for your protection. All notices are to be kept in good condition. Replace any unreadable or damaged labels.

<b>⚠ WARNING</b>
<ul style="list-style-type: none"> <li>• DO NOT OVERLOAD CIRCUIT.</li> <li>• ALWAYS ELECTRICALLY GROUND THE CHASSIS OR ADAPTOR PLUG.</li> <li>• DO NOT DEFORM PLUG OR CORD.</li> <li>• FOLLOW NATIONAL AND LOCAL ELECTRICAL CODES.</li> <li>• KEEP COMBUSTIBLES AWAY.</li> </ul>
<b>FAILURE TO COMPLY RISKS EQUIPMENT DAMAGE, FIRE OR SHOCK HAZARD.</b>
READ THE ENTIRE OPERATING MANUAL BEFORE USING THIS PRODUCT <small>00986.0002E 5/98 ©1994 Bunn-O-Matic Corporation</small>

00986.0002

<b>⚠ WARNING</b>	
<b>Moving Parts.</b>  Do not operate unit with this panel removed.	<b>Risk Of Electrical Shock.</b>  Disconnect power before servicing unit.

27442.0000

**CHARGE**  
 Type R134A, Amount 10 oz  
 Design Pressures: High 335 Low 88

33461.0000

### ⚠ CAUTION

**MAXIMUM RINSE WATER TEMPERATURE: 170°F (76.6°C)**  
 Use Bunn-O-Matic tubing, part number 32759.10XX  
 (See Illustrated Parts Catalog for complete part number)  
 for hot water connection.

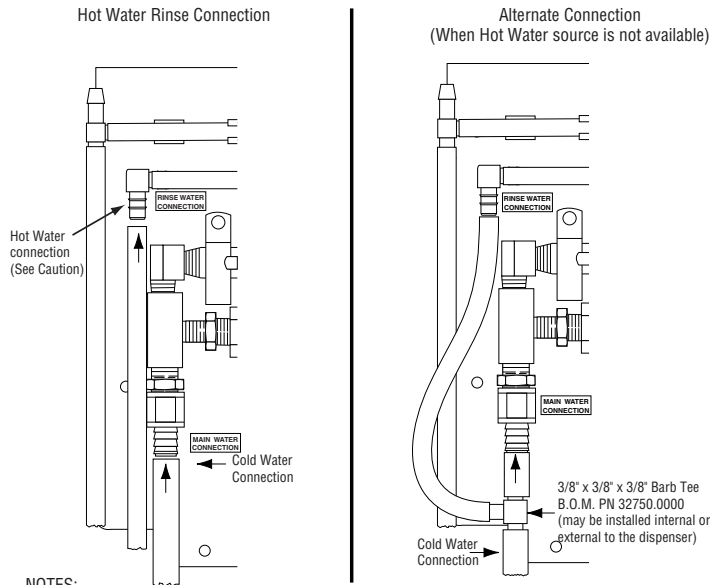

**NOTES:**

- Use Bunn-O-Matic tubing, part number 32759.10XX for all connections. (See Illustrated Parts Catalog for complete part number)
- Clamp all hose connections with Bunn-O-Matic part number 21275.0003 (hose clamp)

33648.0000C 01/01 ©2000 BUNN-O-MATIC CORPORATION

33648.0000

## INITIAL SET-UP

**CAUTION:** The dispenser is very heavy! Use care when lifting or moving it. Use at least two people to lift or move the dispenser. Place the dispenser on a sturdy counter or shelf able to support at least 250 lbs. (113.4 kg). The FCD-4 is designed for indoor use only.

1. Set the dispenser on the counter where it will be used. The FCD-4 requires a minimum of 4 inches (102 mm) of air clearance at the rear and 8 inches (203 mm) of air clearance above the dispenser. Minimal clearance is required between the dispenser sides and the wall or another appliance. For optimum performance, **do not** let warm air from surrounding machines blow on the FCD-4. Leave some space so the dispenser can be moved for cleaning.
2. Assemble the cup stop in the third slot of the drip tray cover as shown in Fig 1.
3. Place the cover/cup stop assembly on the drip tray and install on the dispenser.

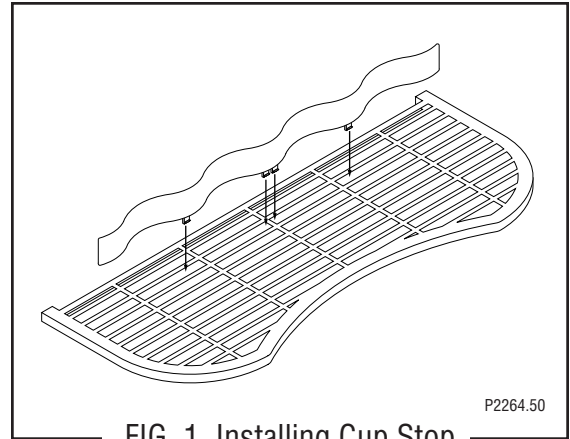

FIG 1 Installing Cup Stop

## ELECTRICAL REQUIREMENTS

**CAUTION:** The dispenser must be disconnected from the power source until specified in *Electrical Hook-Up*. The dispenser has an attached cord set and requires a 2-wire, grounded, individual branch circuit rated 120 volts ac, 15 amp, single phase, 60Hz. The mating connector must be a NEMA5-15R. (Refer to the dataplate for exact electrical requirements.)

### ELECTRICAL HOOK-UP

**CAUTION:** Improper electrical installation will damage electronic components.

1. An electrician must provide electrical service as specified.
2. Using a voltmeter, check the voltage and color coding of each conductor at the electrical source.
3. Connect the dispenser to the power source.
4. If plumbing is to be hooked up later, be sure the dispenser is disconnected from the power source. If plumbing has been hooked up, the dispenser is ready for *Initial Fill*.

## PLUMBING REQUIREMENTS

This dispenser must be connected to a **COLD WATER** system with operating pressure between 20 and 100 psi (138 and 690 kPa). This water source must be capable of producing a minimum flow rate of 3 fluid ounces (88.7 milliliters) per second. A shut off valve should be installed in the line before the dispenser. Install a regulator in the line when pressure is greater than 100 psi (690 kPa) to reduce it to 50 psi (345 kPa). The main water inlet is a 3/8" (9.52 mm) barb connection.

Additionally, the dispenser's rinse connection may be connected to a **HOT WATER** system.

### Caution:

### MAXIMUM RINSE WATER TEMPERATURE: 170 degrees F (76.6 degrees C)

Use BUNN-O-MATIC tubing, part number 32759.10\_\_ (see Illustrated Parts Catalog for complete part number) for hot water connection.

The rinse water operating pressure must be between 20 and 100 psi (138 and 690 kPa). A shut off valve should be installed in the line before the dispenser. Install a regulator in the line when pressure is greater than 100 psi (690 kPa) to reduce it to 50 psi (345 kPa). The rinse water inlet is a 3/8" (9.52 mm) barb connection.

**NOTE-** At least 18 inches (457 mm) of an FDA approved flexible beverage tubing, such as reinforced braided polyethylene or silicone, before the dispenser will facilitate movement to clean the countertop. It can be purchased direct from BUNN-O-MATIC (part number 32759.10\_\_ [see Illustrated Parts Catalog for complete part number.]) BUNN-O-MATIC does not recommend the use of saddle valves to install the dispenser. The size and shape of the hole(s) made in the supply line(s) by saddle valves may restrict water flow.

**Note-** A water strainer (Bunn-O-Matic part number 23720.1000) should be installed in line, prior to the flexible water line.

**This equipment must be installed to comply with the Basic Plumbing Code of the Building Officials and Code Administrators International, Inc. (BOCA) and the Food Service Sanitation Manual of the Food and Drug Administration (FDA).**

## PLUMBING HOOKUP

**CAUTION:** The dispenser must be disconnected from the power source throughout the plumbing hookup.

All plumbing connections are located behind the dispenser's splash panel. Water lines may enter the dispenser through the access holes in either the bottom panel or the rear panel of the dispenser.

To access plumbing connections: remove the drip tray assembly; remove the two screws securing the splash panel to the dispenser; lower the splash panel from the front of the dispenser. *Refer to FIG 2 for proper water hookup.*

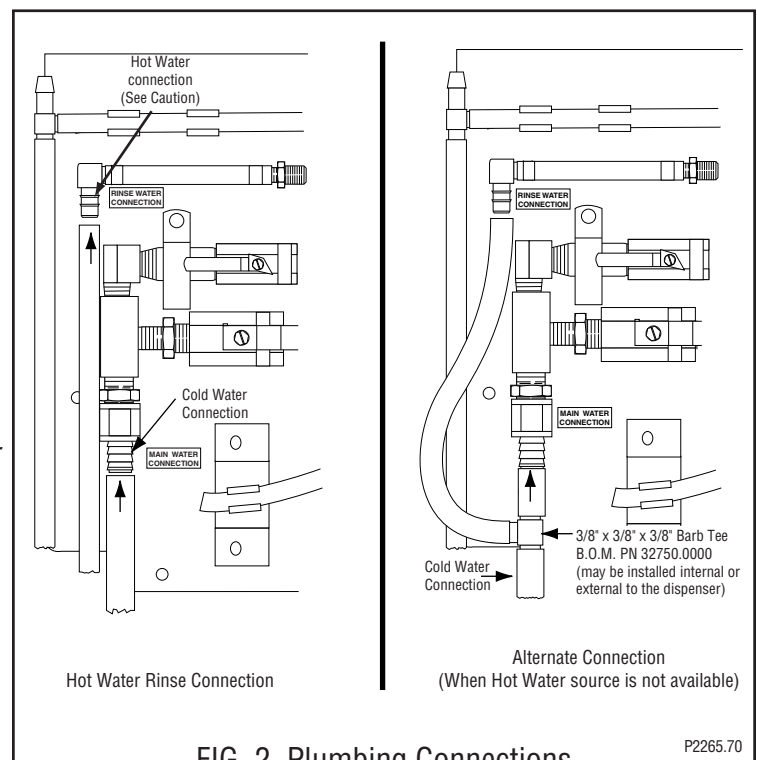

## OPERATING CONTROLS

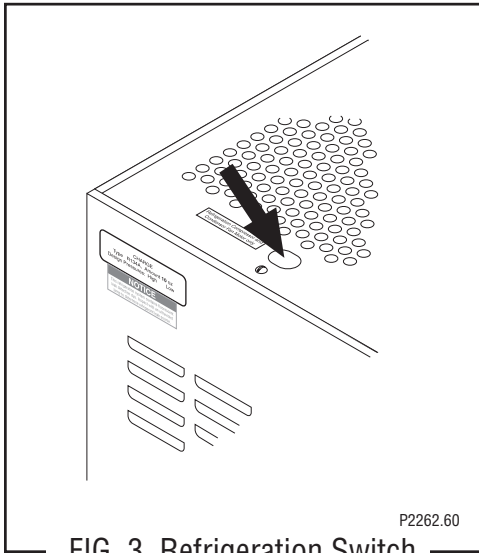

FIG 3 Refrigeration Switch

### Refrigeration Switch

The refrigeration switch is located on the top of the dispenser near the left rear corner. This switch controls power to the compressor and the condenser fan motor.

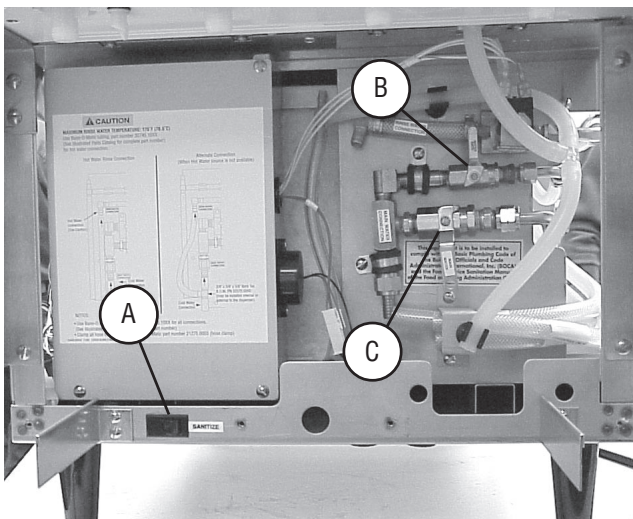

FIG 4 Sanitize Switch & Water Valves

- A. Sanitize Switch
- B. Water Bath Valve
- C. Main Water Valve

### Sanitize Switch

The sanitize switch is located behind the drip tray in the lower left corner of the chassis. The drip tray can be removed to provide easy access to the switch. The sanitize switch is used to enter and exit the sanitize mode and to initiate the sanitize automatic cycle. Refer to Weekly Sanitizing in the Cleaning section for detailed instructions on the use of this switch.

### Water Bath and Main Water Valves

These valves are manually operated and are located above the drip tray, behind the splash panel. The drip tray and splash panel must be removed to gain access to the valves. The upper (small) one is the water bath valve and the lower (large) one is the main water valve. Refer to the Initial Fill section for detailed instructions on the use of these valves.

## OPERATING CONTROLS (cont.)

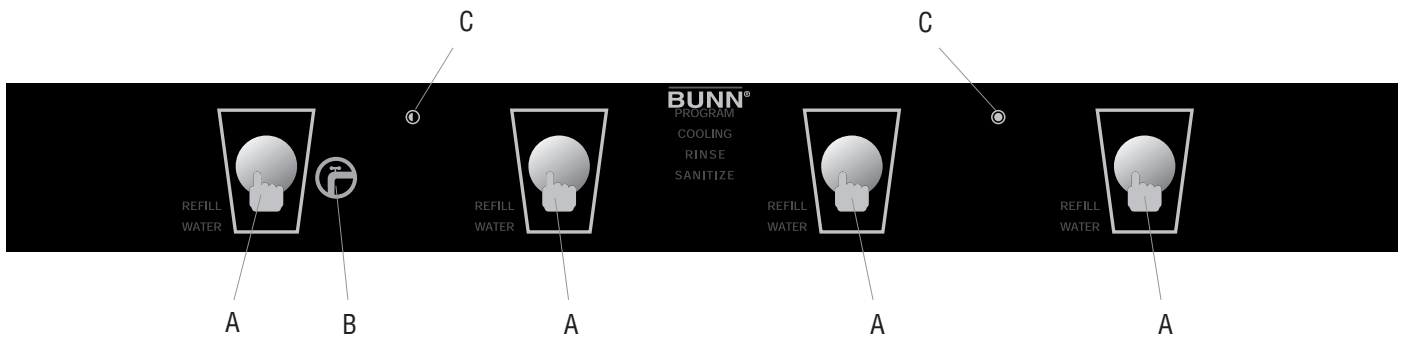

FIG 5 Press and Hold Models

- A. Product Dispense Switch  
Pressing and holding switch will initiate product flow from the respective nozzle; releasing the switch will stop the flow.
- B. Chilled Water Dispense Switch  
Pressing and holding switch will initiate chilled water flow from the nozzle; releasing the switch will stop the flow.
- C. Hidden Switch  
These switches are used to access, change and exit the dispenser program mode.

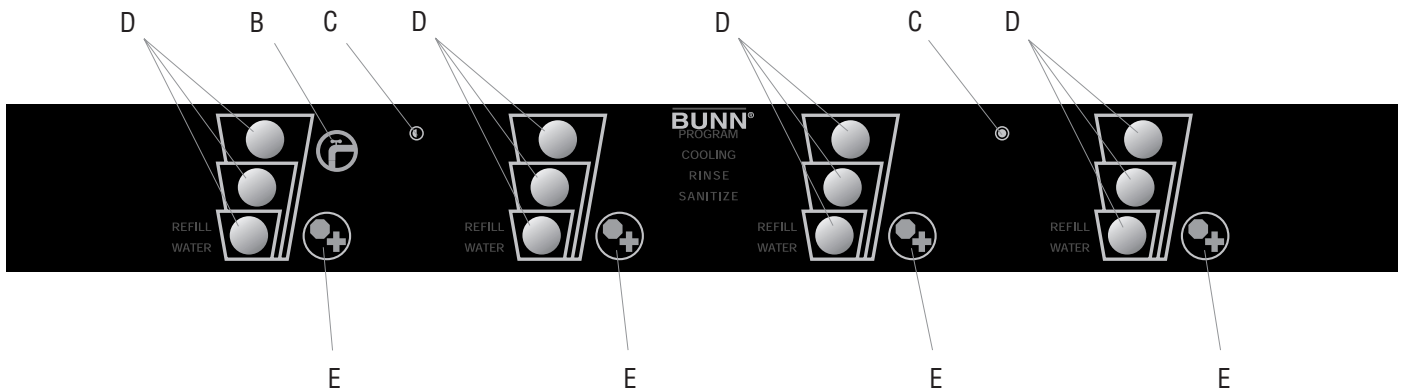

FIG 6 Portion Control Models

- B. Chilled Water Dispense Switch  
Pressing and holding switch will initiate chilled water flow from the nozzle; releasing the switch will stop the flow.
- C. Hidden Switch  
These switches are used to access, change and exit the dispenser program mode.
- D. Product Dispense Switch  
Momentarily pressing and releasing one of the switches will initiate a timed dispense. Each station has three different timed dispenses which are preset at the factory. Refer to DISPENSER USE section for preset volumes and adjustment procedures.
- E. Plus/Stop Switch  
This switch can be used to “top-off” a beverage. Pressing and holding switch will initiate product flow from the respective nozzle; releasing the switch will stop the flow. Momentarily pressing this switch during a timed dispense will stop the flow.

## INITIAL FILL

**CAUTION:** The dispenser must be disconnected from the power source throughout the initial fill except when specified in the instructions.

1. Remove drip tray assembly and splash panel from the dispenser.
2. Pull the overflow tube from its retaining clip and place the end into an empty 64 fluid ounce (2 liter) container.
3. Ensure that the Main Water Valve and the Water Bath Valve Fig 4, are turned off (handles positioned at 6 o'clock and 12 o'clock, respectively,) and that the Refrigeration Switch Fig 3, is in the OFF (rear) position.
4. Turn on the water supply.
5. While observing the water bath sight gauge (the clear tube located just to the left of the plumbing connections,) begin filling the water bath by rotating the handle of the Water Bath Valve counterclockwise to the 9 o'clock position.
6. When the water level in the sight gauge comes within 1 inch (25.4 mm) of the clear plastic tee, reduce the water flow by rotating the handle of the Water Bath Valve clockwise to the 11 o'clock position.
7. When the water in the water bath sight gauge begins to trickle down into the drip tray, turn the Water Bath Valve off by rotating the handle clockwise to the 12 o'clock position.
8. Connect the dispenser to the power source.
9. After approximately 3 minutes (this allows the recirculating pump and cabinet cooling components an opportunity to fill with water,) top off the water bath tank by rotating the handle of the Water Bath Valve counterclockwise to the 11 o'clock position.
10. Again, when the water in the water bath sight gauge begins to trickle down into the drip tray, turn the Water Bath Valve off by rotating the handle clockwise to the 12 o'clock position.
11. Place the Refrigeration Switch ON (forward.)
12. It will take approximately 4 hours at 70 degrees F (21 degrees C) ambient to create the ice bank required for full dispenser performance. During this time, some further trickling from the water bath is expected due to expansion caused by ice bank formation. While the refrigeration system is creating the ice bank, the dispenser may be readied for use as described in *Loading, Priming and Adjustment*.
13. The dispenser will safely store concentrate once the "COOLING" indicator completely extinguishes (not lit steadily or flashing.)
14. After the refrigeration compressor switches off, turn Main Water Valve on by rotating the handle counterclockwise to the 3 o'clock position. Secure the overflow tube into its retaining clip and replace the splash panel and drip tray assembly.

## LOADING

### Frozen Concentrates

1. Thaw the frozen concentrate in a refrigerated 35-40 degrees F (1.6-4.4 degrees C) environment for 36 to 48 hours before use.
2. Thoroughly mix the thawed concentrate by vigorously shaking the product container.
3. Open the dispenser door.
4. Prior to placing the product container in the dispenser, make sure that the o-ring on the container adapter is lubricated. This will ease removal of the container when it becomes necessary.
5. Place the product container in the desired position and press it firmly into the bottle adapter opening.
6. Open the vent hole in the product container.

**Note:** Concentrate in the container must be completely thawed and be within the temperature range of 35-40 degrees F (1.6-4.4 degrees C.) Product outside of this temperature range, especially below, will produce an "out of brix" drink.



## INITIAL FILL (cont)

### Ambient Concentrates (Optional)

1. Install an Ambient Concentrate Conversion Kit (BUNN-O-MATIC part number 33699.0000) per the instructions provided in the kit.
2. Attach the concentrate product hose to the appropriate concentrate line located behind the dispenser's splash panel.
3. Attach the other end of the product hose to the product container through an appropriate fitting.

### PRIMING

1. Open the dispenser door
2. Load concentrate per instructions in section titled *Loading*.
3. Close the dispenser door.  
**Note:** The dispenser will not operate with the door open.
4. Place a large container under the appropriate dispense nozzle.
5. Dispensers with Press and Hold Feature:  
Press and hold the "Product Dispense Switch" Fig 5, until concentrate dispenses from the dispense nozzle.  
Dispensers with Portion Control Feature:  
Press and hold the "+/STOP Switch" Fig 6, until concentrate dispenses from the dispense nozzle.  
**Note:** This may take several seconds, depending on the installation and programmed pump speed.

## DISPENSER USE

### **Press and Hold Models** (Refer to Fig 5)

1. Place a cup on the drip tray beneath the desired dispensing nozzle.
2. Press and hold the “Product Dispense” or “Chilled Water” switch until the beverage/water reaches the desired level, then release.

### **Portion Control Models** (Refer to Fig 6)

1. Place a cup on the drip tray beneath the desired dispensing nozzle.
2. Momentarily press the appropriate cup size switch to dispense the beverage. The dispenser is factory preset to produce the approximate beverage sizes as follows:

Small (4.0 seconds): approximately 7 fl.oz. (207 ml)

Medium (6.9 seconds): approximately 12 fl.oz. (355 ml)

Large (9.1 seconds): approximately 16 fl.oz. (473 ml)

The dispense times can be individually programmed by following the procedures described in *ADJUSTMENT - Cup Size Programming*.

To stop a timed dispense, momentarily press the “+/Stop Switch”.

3. To “top-off” a beverage, press and hold the “+/Stop Switch” until the beverage reaches the desired level, then release.
4. To dispense chilled water, press and hold the “Chilled Water Switch” until the water reaches the desired level, then release.

## CLEANING & PREVENTIVE MAINTENANCE

### General Cleaning and Sanitizing Procedures

Note: The Bunn Juice Dispenser incorporates a rinse reminder feature which lights the rinse led on the front panel when it is time to rinse. See dip switch function list to activate this feature.

### Daily: Rinse Procedure

Tools required: 32 oz. (946 ml) minimum empty container

1. Open the refrigerated compartment's door to access the "DISPENSE/RINSE" Knobs Fig 7.

2. Select the stations that will be rinsed and then rotate the appropriate Knob(s) to the rinse position. It is recommended that ALL dispense heads be rinsed daily.

**Note:** If a station is in service lockout, leave its knob in the Dispense position.

3. Close the refrigerated compartment's door.

4. Place the empty container under the dispense nozzle to catch the rinse water.

**(CAUTION: THE BUNN JUICE DISPENSER CAN BE PLUMBED FOR A HOT WATER RINSE. RINSE WATER CAUGHT IN THIS STEP SHOULD BE HANDLED WITH EXTREME CARE.)**

5. Press and release the appropriate "Product Dispense Switch" Fig 5. This will initiate a timed rinse cycle. Portion control users can press any of the 3 "Product Dispense Switches" Fig 6, to initiate a timed rinse cycle.

6. Repeat for each dispense head.

7. Open the refrigerated compartment's door and return each knob to the dispense position.

8. Actuate the station's Dispense Switch until concentrate appears from the dispense nozzle.

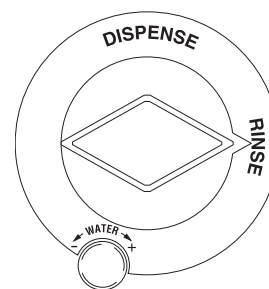

FIG 7 Dispense/Rinse Switch

### Daily: Parts Washing

1. Remove and wash the dispense nozzle(s), mixing element(s), drip tray, drip tray cover, and cup stop in a mild detergent solution. Rinse thoroughly.

2. Wipe splash panel, areas around dispense nozzle(s), and drip trough in refrigerated compartment with a clean, damp cloth.

### Weekly: Sanitizing

Tools required: Nozzle tubing (BUNN-O-MATIC part number 03289.1002) recommended when sanitizing multiple dispense heads simultaneously, 1 empty 5 gallon (18.9 L) bucket, 1 packet of Kay 5 sanitizer, and clean, empty concentrate containers.

Note: The Bunn juice dispenser features a semiautomatic sanitizing program. When sanitizing multiple heads simultaneously, attach Bunn sanitize tubing (BUNN-O-MATIC part number 03289.1002) on the end of each dispense nozzle and run tubing to the 5 gallon (18.9 L) bucket.

1. Remove any juice concentrate from the dispenser and store in a separate refrigerated compartment.

2. Perform the rinse procedures as previously described. (Note: If the dispenser is plumbed for hot water rinse, proceed to step 9.)

3. Fill clean empty concentrate container(s) with approximately 32 oz. (946 ml) of the hot tap water (approximately 140°F (60°C). Load the containers of hot water into the dispenser (just like concentrate). Verify the rinse knobs are in the "DISPENSE" position.

4. Remove the drip tray and verify that the nozzle tubes are positioned within the empty bucket.

5. Press and hold the "Sanitize Switch" Fig 4, located on the front left portion of the base, for 5 seconds. The "SANITIZE" indicator on the front panel will begin to flash and the beeper will sound twice indicating that you have entered the sanitize mode.

6. Select the dispense stations by pressing the "Dispense Switch" for that station. Use the "+/Stop Switch" for

## CLEANING (cont)

portion control dispensers. The “REFILL” indicator will light and the beeper will sound for the dispense head selected.

7. Once the dispense heads have been selected, press and hold the “Sanitize Switch” for 5 seconds again to initiate the automatic cycle. (When the cycle is initiated the “SANITIZE” indicator lights steadily and the “REFILL” indicator for each station being sanitized will flash.)

**Note:** The sanitize routine takes 8 minutes. During the sanitize routine the following steps will occur in sequence:

- A) The pumps at the selected dispense heads will run for 1 minute, or until the bottles filled with hot water empty, whichever occurs first.
- B) The dispenser will sit idle for 5 minutes.
- C) The pumps at the selected dispense heads will run for 2 minutes or until the bottles filled with hot water empty, whichever occurs first.
- D) The beeper will sound once every 3 seconds to indicate completion of the sanitize routine.

**Note:** To terminate a sanitize program mid-cycle, momentarily press and release the “Sanitize Switch” and proceed to step 17. The sanitize program should be restarted from step 1 to ensure proper sanitization.

8. Once the cycle is completed, disconnect the sanitizing hose(s) from the nozzle(s) and empty the bucket.
9. Remove each dispense nozzle and mixing element and run under hot tap water to remove excess pulp.
10. Prepare 2.5 gal. (9.46 L) of sanitizing solution by dissolving 1 packet of Kay 5 sanitizer into 2.5 gal. (9.46 L) of 120°F (48.9°C) water to ensure 100 ppm of available chlorine.
11. Place nozzle(s) and mixing element(s) in a separate 1 quart container of sanitizing solution and mix thoroughly. Allow the part to soak for 2 minutes.
12. Clean the dispense nozzle receptacle(s) (dispense valves) with the sanitizing solution and a soft bristle brush.
13. Clean the concentrate bottle’s inlet adapter(s) using the sanitizing solution and a soft bristle brush.
14. Replace the mixing element(s) and nozzle(s), reattach the sanitizing hose(s) to the nozzle(s), and insert the hoses into the catch bucket.
15. Fill approximately 64 ounces (1.89 L) of clean sanitizing solution into clean, empty concentrate container(s). Do not use the sanitizing solution used in step 11. Load the containers into the dispenser.
16. Repeat steps 5 through 8.

**Note:** The sanitize routine takes 8 minutes. During the sanitize routine the following steps will occur in sequence:

- A) The pumps at the selected dispense heads will run for 1 minute, or until the bottles filled with sanitizing solution empty, whichever occurs first.
- B) The dispenser will sit idle for 5 minutes.
- C) The pumps at the selected dispense heads will run for 2 minutes or until the bottles filled with sanitizing solution empty, whichever occurs first.
- D) The beeper will sound once every 3 seconds to indicate completion of the sanitize routine.

17. Replace the sanitizing solution with concentrate and reattach the drip tray.
18. Activate a rinse cycle at each station as described in DAILY RINSE PROCEDURE.
19. At each station, actuate the Dispense Switch until juice appears. Then pour one 12 ounce (354.9 ml) glass of juice and discard.
20. Wipe internal and external surfaces with a clean, damp cloth.

## **CLEANING (cont)**

### **Monthly: Clean Condenser Air Filter**

1. Remove the condenser air filter located on the rear of the dispenser.
2. Using a water spray, clean the air filter.

### **Annually: Replace Pump Tubing**

1. Open dispenser door.
2. Remove all product containers and place them in a refrigerated (35-40 degrees F [1.6-4.4 degrees C]) environment. Disconnect all connections to ambient products from the bottle adapter.
3. Close the dispenser door and dispense product at each station until the product runs clear.
4. Remove the drip tray assembly and splash panel from the dispenser.
5. Replace the drip tray assembly.
6. Turn the Main Water valve to the 6 o'clock position.
7. Open the dispenser door and remove the product shelf.
8. Remove the DISPENSE/RINSE knobs Fig 7, all dispense nozzles, the 2 screws securing the cover to the dispense platform, and the cover.
9. Disconnect the dispense platform's water lines from the supply lines inside the refrigerated cabinet and disconnect the wiring connections from the cabinet receptacles.
10. Remove the 2 thumb-screws securing the dispense platform to the cabinet .
11. Slowly pull the dispense platform forward to allow access to the rear wiring harness connector.
12. Disconnect the rear wiring harness connector from its receptacle.
13. Pull the dispense platform completely out of the cabinet and place it on a flat work surface.
14. Close the dispenser door.
15. Remove the screw securing the tubing retainer plate to the pump body and set it and the tubing retainer plate aside.
16. Gently pull the socket head screw from its notch in the pump body, releasing the spring tension on the pump band.
17. Gently pull the pump tube from around the pump's rotor.
18. Inspect the pump band for signs of wear. Replace if necessary.
19. Release the clamps securing the old pump tubing to the plastic elbows.
20. Pull the plastic elbows from the old pump tubing, and discard the old pump tubing.
21. Insert the plastic elbows into the new pump tubing and secure it with the clamps.
22. Apply lubricant (BUNN-O-MATIC part number M2548.0000) to the new pump tubing's rotor side.
23. Gently wrap the new pump tubing around the pump's rotor, making sure that the elbows and clamps end up on the top-side of the pump body and don't protrude through the exit slots.
24. Replace the socket-head screw into its notch in the pump body.
25. Replace the tubing retainer plate and its retaining screw.
26. Repeat steps 15 through 24 for the remaining pumps.
27. Replace the dispense platform into the refrigerated cabinet, making sure to reconnect all electrical and water connections.
28. Turn the Main Water Valve to the 3 o'clock position. Check for leaks.
29. Replace the thumb-screws, cover, cover screws, DISPENSE/RINSE knobs and dispense nozzles.
30. Turn all DISPENSE/RINSE knobs to the RINSE positions. Close the door and run a rinse at each station. Check for leaks.
31. Replace product shelf and product containers. Reconnect any connections to ambient product containers.
32. Prime the pumps as described in "PRIMING" in the Initial Fill Section.

## ADJUSTMENT & OPTIONAL SETTINGS

### SETTING THE MIX RATIO/BRUX

#### Ratio Cup Method

1. Adjust the water flow as described in *Water Flow Testing and Adjustment*.
2. Remove the dispense nozzle from the appropriate dispense position.
3. Assemble, lubricate, and install the Flow Separator Assembly (BUNN-O-MATIC part number 32629.0000) into the dispense nozzle receptacle (dispense valve,) making sure to point the arrow on the separator body away from the dispenser.
4. Place an empty container under the Flow Separator Assembly.
5. Dispensers with Press and Hold Feature:  
Press and hold the “Product Dispense Switch” Fig 5, until water and concentrate begin flowing freely from the Flow Separator Assembly nozzles.
- Dispensers with Portion Control Feature:  
Press and hold the “+/Stop Switch” Fig 6, until water and concentrate begin flowing freely from the Flow Separator Assembly nozzles.
6. Place the empty bruxing cup (BUNN-O-MATIC part number 33095.0000) under the Flow Separator Assembly nozzles, small (concentrate) chamber to the left and large (water) chamber to the right.
7. Dispensers with Press and Hold Feature:  
Press and hold the “Product Dispense Switch” until concentrate reaches the 1 oz. (black line) mark.
- Dispensers with Portion Control Feature:  
Press and hold the “+/Stop Switch” until concentrate reaches the 1 oz. (black line) mark.
8. Read the level in the water chamber. This reading directly determines the mix ratio (i.e. If the water level reads 4.0 oz., then the mix ratio is 4 [water] + 1 [concentrate].)
9. Adjust the pump speed (down to increase the ratio, up to decrease the ratio) to achieve the correct mix ratio as described in *Pump Speed Programming*.
10. Remove the Flow Separator Assembly and replace the dispense nozzle assembly into the dispense nozzle receptacle (dispense valve.)

#### Temperature Compensated Refractometer Method

1. Adjust the water flow as described in *Water Flow Testing and Adjustment*.
2. Place an empty container under the appropriate dispense nozzle.
3. Dispensers with Press and Hold Feature:  
Press and hold the “Product Dispense Switch” Fig 5, until water and concentrate begin flowing freely from the dispense nozzle.
- Dispensers with Portion Control Feature:  
Press and hold the “+/Stop Switch” Fig 6, until water and concentrate begin flowing freely from the dispense nozzle.
4. Discard the product caught previously and place the empty container back under the dispense nozzle.
5. Dispensers with Press and Hold Feature:  
Press and hold the “Product Dispense Switch” until the cup is filled.
- Dispensers with Portion Control Feature:  
Press and hold the “+/Stop Switch” until the cup is filled.
6. Stir the contents of the cup, and use the refractometer (according to the manufacturer’s instructions) to check the brix %.
7. Adjust the pump speed (down to decrease the brix %; up to increase the brix %) to achieve the correct brix % as described in *Pump Speed Programming*.

## ADJUSTMENT & OPTIONAL SETTINGS (cont)

### Water Flow Testing and Adjustment

1. Enter the “Pump Speed Programming” mode by simultaneously pressing both “Hidden Switches” Fig 5 or Fig 6. Note that the beeper sounds twice and that the “PROGRAM” indicator begins flashing.
2. Place a graduated measuring cup or the large chamber of the empty brining cup (BUNN-O-MATIC part number 33095.0000) under the appropriate dispense nozzle.
3. Press and hold the desired “Product Dispense Switch” Fig 5 (“+/Stop Switch” Fig 6, for portion control dispensers) for 5 seconds. Note that the beeper sounds once per second (6 times, total) during this period.
4. At the end of the 5 second period, the selected position will dispense water (no concentrate) for only 3 seconds.
5. Measure the water dispensed.
6. Adjust the water flow rate Fig 8, (clockwise to increase flow rate; counterclockwise to decrease flow rate) to the corresponding product mix ratio as follows:

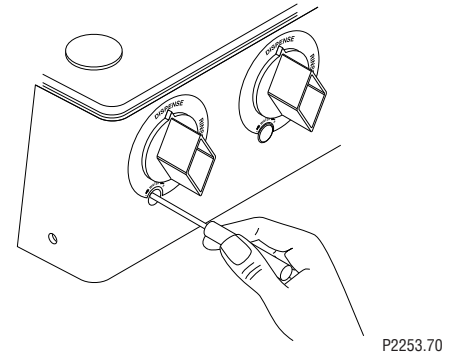

FIG 8 Adjusting Water Flow

Mix Ratio (water + concentrate)	Adjust water flow rate to:	Product	Brix %
2+1	3.75 fluid ounces (111 ml) per 3-second test	Prune Juice	16.0%
		Other	*
4+1	4.5 fluid ounces (133 ml) per 3-second test	Orange Juice	11.8%
		Pineapple Juice	12.8%
		Cranberry Fruit Cocktail	14.0%
		Grapefruit Juice	10.6%
		Lemonade	
		Apple Juice	12.0%
		Fruit Punch	
5+1		Grape Juice	13.0%
3+1 through 7+1		Other	*
Above 7+1	6.0 fluid ounces (177 ml) per 3-second test	Other	*

**Note:** Information for specific products listed in this table is to be used for reference only. Consult the product label for exact mix ratio and/or brix %. See product label for target brix %.

7. Repeat steps 3 through 6 as necessary until the correct water flow rate is achieved.
8. Repeat steps 3 through 7 for the remaining dispense positions.
9. Exit the “Pump Speed Programming” mode by simultaneously pressing both “Hidden Switches”. Note that the beeper sounds twice and the “PROGRAM” indicator extinguishes.

### Pump Speed Programming

1. Enter the “Pump Speed Programming” mode by simultaneously pressing both “Hidden Switches”. Note that the beeper sounds twice and that the “PROGRAM” indicator begins flashing.
2. To increase the pump speed, press and hold the right-hand “Hidden Switch” (filled circle) and then momentarily press the “Product Dispense Switch” Fig 5 (“+/STOP Switch” Fig 6, for portion control dispensers). Each time the “Product Dispense Switch (“+/STOP Switch”) is pressed, the motor speed is increased by one step (5 revolutions per minute [RPM].) Note that each step is confirmed by a single flash of the appropriate “REFILL” indicator and a single tone from the beeper.
3. To decrease the pump speed, press and hold the left-hand “Hidden Switch” (half-filled circle) and then momentarily press the “Product Dispense Switch (“+/STOP Switch” for portion control dispensers). Each time the “Product Dispense” (“+/STOP”) Switch is pressed, the motor speed is decreased by one step (5 RPM.) Note

## ADJUSTMENT & OPTIONAL SETTINGS (cont)

that each step is confirmed by a single flash of the appropriate “REFILL” indicator and a single tone from the beeper.

4. Repeat as necessary at the remaining dispense stations.
5. Exit the “Pump Speed Programming” mode by simultaneously pressing both “Hidden Switches”. Note that the beeper sounds twice and that the “PROGRAM” indicator extinguishes.

### Chilled Water Flow Testing and Adjustment

1. Enter the “Pump Speed Programming” mode by simultaneously pressing both “Hidden Switches”. Note that the beeper sounds twice and that the “PROGRAM” indicator begins flashing.
2. Place a graduated measuring cup or the large chamber of the empty brining cup (BUNN-O-MATIC part number 33095.0000) under the appropriate dispense nozzle.
3. Press and hold the “Chilled Water Switch” Fig 5 or Fig 6, for 5 seconds. Note that the beeper sounds once per second (6 times, total) during this period.
4. At the end of the 5 second period, the chilled water will dispense for 3 seconds.
5. Measure the water dispensed. (Approx. 4.5 fl. oz. [133 ml])
6. If adjustment is required, remove all concentrate bottles from dispenser and disconnect any optional ambient concentrate hoses. Remove product shelf from dispenser.
7. Adjust the Chilled Water Flow Valve Fig 9, clockwise to decrease flow rate; counterclockwise to increase flow rate.
8. Repeat steps 3 through 6 as necessary until the desired water flow rate is achieved.
9. Exit the “Pump Speed Programming” mode by simultaneously pressing both “Hidden Switches”. Note that the beeper sounds twice and that the “PROGRAM” indicator extinguishes.



P2263

FIG 9 Chilled Water Flow Valve

### Cup Size Programming (Portion Control Dispensers Only)

1. Enter the “Cup Size Programming” mode by simultaneously pressing the “LARGE” and “SMALL” cup size switches at any dispense station. Note that the beeper sounds twice and that the “PROGRAM” indicator lights steadily.
2. Press and hold the desired cup size switch at the appropriate dispense position until the correct cup volume is achieved. Top up as necessary by momentarily pressing the same cup size switch. Note that if DIP switch #2 on the control board is set to the “on” position, concentrate must be present in order to dispense or program cup sizes.
3. Repeat as necessary for the remaining cup sizes and dispense stations.
4. Exit the “Pump Speed Programming” mode by pressing any of the “+/STOP Switches”. Note that the beeper sounds twice and that the “PROGRAM” indicator extinguishes.

### Dispenser Lockout

Dispense and Rinse functions of the dispenser can be electronically locked-out to prevent unauthorized use of the dispenser, while keeping the refrigeration system running.

1. Enter the “Pump Speed Programming” mode by simultaneously pressing both “Hidden Switches”. Note that the beeper sounds twice and that the “PROGRAM” indicator begins flashing.
2. Enter a “Lockout” password as follows:
  - a) Press and hold either “Hidden Switch”.



## ADJUSTMENT & OPTIONAL SETTINGS (cont)

- b) In a 5 second period, press and release the “Chilled Water Switch” the number of times that you want the password set to (maximum of 10.) For example: If you want the password set to 3, press and release the “Chilled Water Switch” 3 times in the 5 second period.
- c) Release the “Hidden Switch”.
- d) At the end of the 5 second period, the password will be confirmed by the “REFILL” indicators flashing the password.
3. Exit the “Pump Speed Programming” mode by simultaneously pressing both “Hidden Switches”. Note that the beeper sounds twice and that the “PROGRAM” indicator extinguishes.
4. To lockout the dispenser, proceed as follows:
  - a) Press and hold either “Hidden Switch”.
  - b) In a 5 second period, press and release the “Chilled Water Switch” the “password” number of times. For example: If the password is set to 3, press and release the “Chilled Water Switch” 3 times in the 5 second period.
  - c) Release the “Hidden Switch”.
  - d) At the end of the 5 second period, the dispenser will extinguish the merchandising lamp, and all dispense functions will be disabled.
5. To enable the dispenser, proceed as follows:
  - a) Press and hold either “Hidden Switch”.
  - b) In a 5 second period, press and release the “Chilled Water Switch” the “password” number of times. For example: If the password is set to 3, press and release the “Chilled Water Switch” 3 times in the 5 second period.
  - c) Release the “Hidden Switch”.
  - d) At the end of the 5 second period, the dispenser will light the merchandising lamp, and dispense functions will be enabled.
6. If the password is forgotten, it can be reset to “0” (dispenser lockout disabled) as follows:

**Note:** The following procedure also clears the programming and service lockout password.

- a) Disconnect the dispenser from its power source.
- b) Place the “Refrigeration Switch” Fig 3, in the OFF (reward) position.
- c) While pressing and holding the “Chilled Water Switch”, connect the dispenser to its power source.
- d) Continue to hold the “Chilled Water Switch” until the dispenser beeps three times, then release.
- e) The passwords are now returned to “0” (no programming or service lockout password/dispenser lockout disabled.)
- f) After 3 minutes, place the “Refrigeration Switch” in the ON (forward) position.

### Service Lockout

Should a dispense station become inoperative and require service, the station’s dispense and rinse functions can be independently locked out, while keeping the remaining stations running.

1. To place a single dispense station in “Service Lockout,” open the dispenser door, press and hold either “Hidden Switch” and the desired dispense station “Product Dispense” (“+/Stop”) switch for 10 seconds.
2. At the end of the 10 second period, the beeper will sound a double tone and the dispense position will be disabled. Place the DISPENSE/RINSE Knob to “DISPINSE” and close the dispenser door.
3. To remove a dispense station from “Service Lockout,” open the dispenser door, press and hold either “Hidden Switch” and the desired dispense station “Product Dispense” (“+/Stop”) switch for 10 seconds.
4. At the end of the 10 second period, the beeper will sound a double tone and the dispense position will be enabled. Close the dispenser door.

## ADJUSTMENT & OPTIONAL SETTINGS (cont)

### Password Protection

The programming modes and service lockout function may be password protected to prevent accidental or unauthorized access to these features. The dispenser is shipped from the factory with a password of “0” (no password.)

1. Enter the “Pump Speed Programming” mode by simultaneously pressing both “Hidden switches”. Note that the beeper sounds twice and that the “PROGRAM” indicator begins flashing.
2. Program a password as follows:
  - a) Press and hold either “Hidden Switch”.
  - b) In a 5 second period, press and release the “Sanitize Switch” the number of times that you want the password set to (maximum of 10.) For example: If you want the password set to 3, press and release the “Sanitize Switch” 3 times in the 5 second period.

**Note:** To reset password to “0” (no password) press and hold the “Sanitize Switch”, without either “Hidden Switch” pressed, for the 5 second period. When the password resets to “0”, the beeper will sound and the “Water” indicators will illuminate for approximately 2 seconds.

- c) Release the “Hidden Switch”.
  - d) At the end of the 5 second period, the password will be confirmed by the “WATER” indicators flashing the password.
  - e) From this point forward, the password must be entered before access is allowed to programming modes or the service lockout function.
3. To enter the password, proceed as follows:
  - a) Press and hold either “Hidden Switch”.
  - b) In a 5 second period, press and release the “Sanitize Switch” the password number of times. For example: If the password is set to 3, press and release the “Sanitize Switch” 3 times in the 5 second period.
  - c) Release the “Hidden Switch”.
  - d) Wait for the password to be confirmed by the flashing of the “Water” indicators.
  - e) Enter the desired program mode or select service lockout as normal within the next 5 seconds.

**Note:** If the program mode/service lockout is not selected within 5 seconds, it will be necessary to re-enter the password.

4. If the password is forgotten, it can be reset to “0” (no password) as follows:

**Note:** The following procedure also clears the dispenser lockout password.

- f) Disconnect the dispenser from its power source.
- g) Place the “Refrigeration Switch” in the OFF (rearward) position.
- h) While pressing and holding the “Chilled Water Switch”, connect the dispenser to its power source.
- i) Continue to hold the “Chilled Water Switch” until the dispenser beeps three times, then release.
- j) The passwords are now returned to “0” (no programming or service lockout password/dispenser lockout disabled.)
- k) After 3 minutes, place the “Refrigeration Switch” in the ON (forward) position).

## Dispense Fault List

“REFILL” indicator	Beeper	Fault
2 flashes	2 beeps	Dispense station locked out.
3 flashes	3 beeps	DISPENSE/RINSE sensing fault.
4 flashes	4 beeps	DISPENSE/RINSE knob mis-positioned.
5 flashes	5 beeps	Pump motor stalled/speed sensor inoperative.
All “REFILL” indicators flash 3 times	3 beeps	Dispenser locked out.

## Cooling Fault List

Fault Code	“COOLING” indicator	DBC display (optional)	Fault	Fault Priority
8	8 flashes every 5 seconds	fault 8	Bath water level low. (Also lights all “WATER” indicators)	1
7	7 flashes every 5 seconds	fault 7	Bath temperature probe short circuit.	2
6	6 flashes every 5 seconds	fault 6	Bath temperature probe open circuit.	3
5	5 flashes every 5 seconds	fault 5	Cabinet temperature probe short circuit.	4
4	4 flashes every 5 seconds	fault 4	Cabinet temperature probe open circuit.	5
3	3 flashes every 5 seconds	fault 3	Cooling system failure (disables all dispense functions)	6
0	On steady temperatures	Bath/cabinet	Bath and cabinet temperatures excessive.	7
2	2 flashes every 5 seconds	Bath/cabinet temperatures	Bath temperature excessive.	8
1	1 flash every 5 seconds	Bath/cabinet temperatures	Cabinet temperature excessive.	9

## Dip Switch Function List

Dip Switch	Controls	Off	On
1	“REFILL” indicator when “concentrate out” is detected.	Inactive	Active
2	Lockout dispense components when “concentrate out” is detected.	Inactive	Active ( <b>Note</b> )
3	Number of positions that can dispense/rinse simultaneously.	3	2
4	Rinse timer	Off	On
5	Audio feedback during dispenses.	On	Off
6	Future use.	None	None

**Note:** When dip switch 2 is in the “on” position, the “REFILL” indicator is active, regardless of dip switch 1 position.

# COOLANT SCHEMATIC DIAGRAM

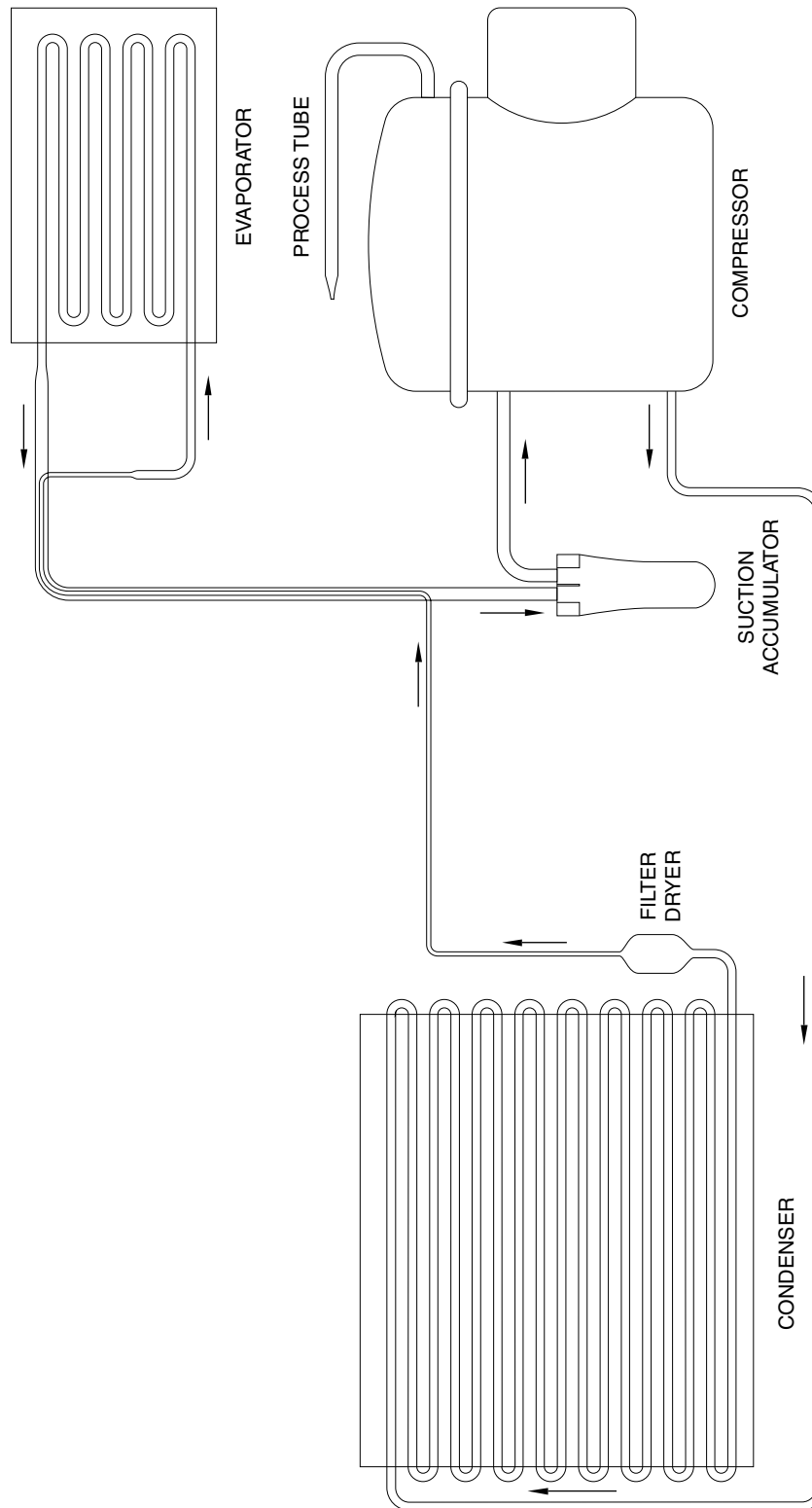

# SCHEMATIC WIRING DIAGRAM

