

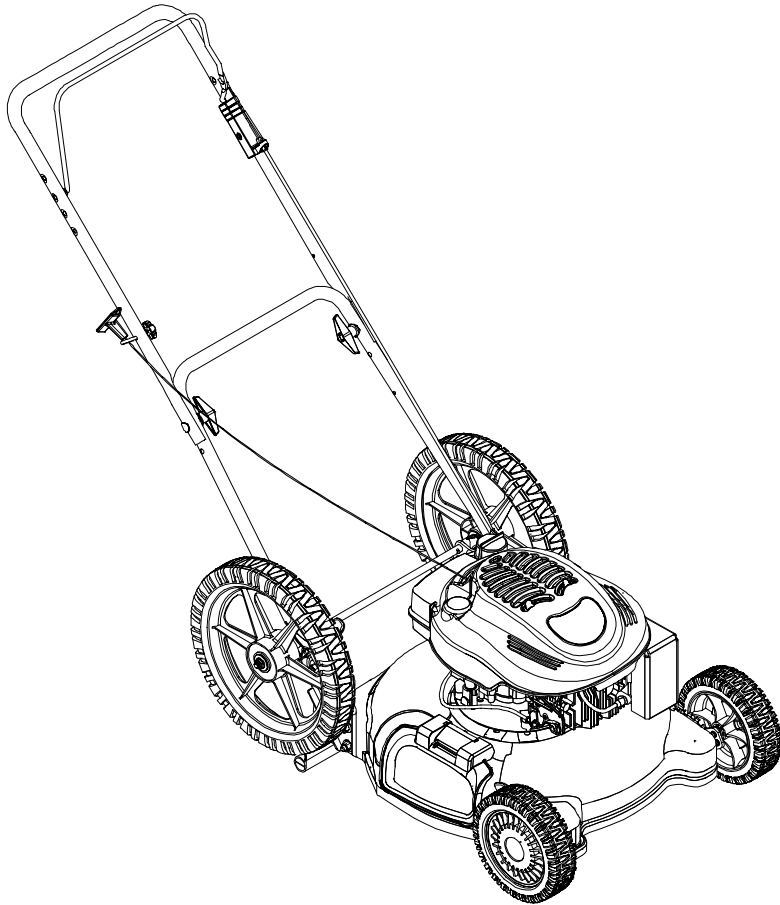

Operator's Manual



20" Mulching Lawn Mower MODEL 573

IMPORTANT: Read safety rules and instructions carefully before operating equipment.

Warning: This unit is equipped with an internal combustion engine and should not be used on or near any unimproved forest-covered, brush-covered or grass-covered land unless the engine's exhaust system is equipped with a spark arrester meeting applicable local or state laws (if any). If a spark arrester is used, it should be maintained in effective working order by the operator. In the State of California the above is required by law (Section 4442 of the California Public Resources Code). Other states may have similar laws. Federal laws apply on federal lands. A spark arrester for the muffler is available through your nearest engine authorized service dealer or contact the service department, P.O. Box 361131 Cleveland, Ohio 44136-0019.

MTD LLC, P.O. BOX 361131 CLEVELAND, OHIO 44136-0019

PRINTED IN U.S.A.

FORM NO. 769-00514
(10/2002)

TABLE OF CONTENTS

Content	Page
Important Safe Operation Practices.....	3
Slope Gauge.....	6
Assembling Your Lawn Mower.....	7
Know Your Lawn Mower.....	8
Operating Your Lawn Mower.....	9
Making Adjustments.....	10
Maintaining Your Lawn Mower.....	10
Off-Season Storage.....	12
Troubleshooting.....	13
Parts List.....	14

FINDING MODEL NUMBER

This Operator's Manual is an important part of your new Lawn Mower. It will help you assemble, prepare and maintain the unit for best performance. Please read and understand what it says.



Before you start assembling your new equipment, please locate the model plate on the equipment and copy the information from it in the space provided below. The information on the model plate is very important if you need help from our Customer Support Department or an authorized dealer.

- You can locate the model number by standing behind the unit in the operating position and looking down at the cutting deck. A sample model plate is explained below. For future reference, please copy the model number and the serial number of the equipment in the space below.

_____	_____
(Model Number)	(Serial Number)
	
www.yardman.com	
MTD, LLC P. O. BOX 361131 CLEVELAND, OH 44136 330-220-4683 800-800-7310	

Copy the model number here: _____

Copy the serial number here: _____

ENGINE INFORMATION

The engine manufacturer is responsible for all engine-related issues with regards to performance, power-rating, specifications, warranty and service. Please refer to the engine manufacturer's Owner's/Operator's Manual packed separately with your unit for more information.

CALLING CUSTOMER SUPPORT

If you have difficulty assembling this product or have any questions regarding the controls, operation or maintenance of this unit, please call the Customer Support Department.



Call 1- (330) 220-4MTD (4683) or 1- (800)-800-7310 to reach a Customer Support representative. Please have your unit's model number and serial number ready when you call. See previous section to locate this information. You will be asked to enter the serial number in order to process your call .

For more details about your unit, visit our website at www.yardman.com

SECTION 1: IMPORTANT SAFE OPERATION PRACTICES



WARNING: This symbol points out important safety instructions which, if not followed, could endanger the personal safety and/or property of yourself and others. Read and follow all instructions in this manual before attempting to operate this machine. Failure to comply with these instructions may result in personal injury. When you see this symbol—HEED ITS WARNING.

WARNING: Engine exhaust, some of its constituents, and certain vehicle components contain or emit chemicals known to State of California to cause cancer and birth defects or other reproductive harm.

WARNING: This machine was built to be operated according to the rules for safe operation in this manual. As with any type of power equipment, carelessness or error on the part of the operator can result in serious injury. This machine is capable of amputating hands and feet and throwing objects. Failure to observe the following safety instructions could result in serious injury or death.

General Operation

1. Read this operator's manual carefully in its entirety before attempting to assemble this machine. Read, understand, and follow all instructions on the machine and in the manual(s) before operation. Be completely familiar with the controls and the proper use of this machine before operating it. Keep this manual in a safe place for future and regular reference and for ordering replacement parts.
2. This machine is a precision piece of power equipment, not a plaything. Therefore, exercise extreme caution at all times. Your unit has been designed to perform one job: to mow grass. Do not use it for any other purpose.
3. Never allow children under 14 years old to operate this machine. Children 14 years old and over should read and understand the operation instructions and safety rules in this manual and should be trained and supervised by a parent. Only responsible individuals who are familiar with these safe operation rules should use this machine.
4. Thoroughly inspect the area where the equipment is to be used. Remove all stones, sticks, wire, bones, toys and other foreign objects which could be tripped over or picked up and thrown by the blade. Thrown objects can cause serious personal injury. Plan your mowing pattern to avoid discharge of material toward roads, sidewalks, bystanders and the like. Also, avoid discharging material against a wall or obstruction which may cause discharged material to ricochet back toward the operator.
5. To help avoid blade contact or a thrown object injury, stay in the operator zone behind the handles and keep bystanders, helpers, children and pets at least 75 feet from the machine while it is in operation. Stop machine if anyone enters the area.
6. Always wear safety glasses or safety goggles during operation and while performing an adjustment or repair to protect your eyes. Thrown objects which ricochet can cause serious injury to the eyes.
7. Wear sturdy, rough-soled work shoes and close-fitting slacks and shirts. Shirts and pants that cover the arms and legs and steel-toed shoes are recommended. Never operate this machine in bare feet, sandals, slippery or light weight (e.g. canvas) shoes.
8. Do not put hands or feet near rotating parts or under the cutting deck. Contact with the blade can amputate hands and feet.
9. A missing or damaged discharge cover can cause blade contact or thrown object injuries.
10. Many injuries occur as a result of the mower being pulled over the foot during a fall caused by slipping or tripping. Do not hold on to the mower if you are falling; release the handle immediately.
11. Never pull the mower back toward you while you are walking. If you must back the mower away from a wall or obstruction first look down and behind to avoid tripping and then follow these steps:
 - a. Step back from the mower to fully extend your arms.
 - b. Be sure you are well balanced with sure footing.
 - c. Pull the mower back slowly, no more than half way toward you.
 - d. Repeat these steps as needed.
5. Do not operate the mower while under the influence of alcohol or drugs.
6. Do not engage the self-propelled mechanism on units so equipped while starting engine.
7. The blade control handle is a safety device. Never attempt to bypass its operation. Doing so makes the safety device inoperative and may result in personal injury through contact with the rotating blade. The blade control handle must operate easily in both directions and automatically return to the disengaged position when released.
8. Never operate the mower in wet grass. Always be sure of your footing. A slip and fall can cause

serious personal injury. If you feel you are losing your footing, release the blade control handle immediately and the blade will stop rotating within three seconds.

9. Mow in daylight or good artificial light. Walk, never run.
10. Stop the blade when crossing gravel drives, walkways or roads.
11. If the equipment should start to vibrate abnormally, stop the engine and check immediately for the cause. Vibration is generally a warning of trouble.
12. Shut the engine off and wait until the blade comes to a complete stop before removing the grass catcher or unclogging the chute. The cutting blade continues to rotate for a few seconds after the engine is shut off. Never place any part of the body in the blade area until you are sure the blade has stopped rotating.
13. Never operate mower without proper trail shield, discharge cover, grass catcher, blade control handle or other safety protective devices in place and working. Never operate mower with damaged safety devices. Failure to do so, can result in personal injury.
14. Muffler and engine become hot and can cause a burn. Do not touch.
15. Only use parts and accessories made for this machine by the original equipment manufacturer (O.E.M). Failure to do so can result in personal injury.
16. If situations occur which are not covered in this manual, use care and good judgment. Contact your dealer for assistance. Telephone 1-800-800-7310 for the name of your nearest dealer.

Slope Operation

Slopes are a major factor related to slip and fall accidents which can result in severe injury. Operation on slopes requires extra caution. If you feel uneasy on a slope, do not mow it. Before operating this unit on a slope or hilly area, use the slope gauge on page 6 to measure slopes. If the slope is greater than 15 degrees, do not mow it.

Do:

1. Mow across the face of slopes; never up and down. Exercise extreme caution when changing direction on slopes.
2. Watch for holes, ruts, rocks, hidden objects, or bumps which can cause you to slip or trip. Tall grass can hide obstacles.
3. Always be sure of your footing. A slip and fall can cause serious personal injury. If you feel you are losing your balance, release the blade control handle immediately, and the blade will stop rotating within 3 seconds.

Do Not:

1. Do not mow near drop-offs, ditches or embankments, you could lose your footing or balance.
2. Do not mow slopes greater than 15 degrees as shown on the slope gauge.
3. Do not mow on wet grass. Unstable footing could cause slipping.

Children

Tragic accidents can occur if the operator is not alert to the presence of children. Children are often attracted to the mower and the mowing activity. They do not understand the dangers. Never assume that children will remain where you last saw them.

1. Keep children out of the mowing area and under the watchful care of a responsible adult other than the operator.
2. Be alert and turn mower off if a child enters the area.
3. Before and while moving backwards, look behind and down for small children.
4. Use extreme care when approaching blind corners, doorways, shrubs, trees, or other objects that may obscure your vision of a child who may run into the mower.
5. Keep children away from hot or running engines. They can suffer burns from a hot muffler.
6. Never allow children under 14 years old to operate a power mower. Children 14 years old and over should read and understand the operation instructions and safety rules in this manual and should be trained and supervised by a parent.

Service

Safe Handling Of Gasoline:

1. To avoid personal injury or property damage use extreme care in handling gasoline. Gasoline is extremely flammable and the vapors are explosive. Serious personal injury can occur when gasoline is spilled on yourself or your clothes which can ignite.
2. Wash your skin and change clothes immediately.
3. Use only an approved gasoline container.
4. Never fill containers inside a vehicle or on a truck or trailer bed with a plastic liner. Always place containers on the ground away from your vehicle before filling.
5. If possible, remove gas-powered equipment from the truck or trailer and refuel it on the ground. If this is not possible, then refuel such equipment on a trailer with a portable container, rather than from a gasoline dispenser nozzle.
6. Keep the nozzle in contact with the rim of the fuel tank or container opening at all times until fueling is complete. Do not use a nozzle lock-open device.

7. Extinguish all cigarettes, cigars, pipes and other sources of ignition.
8. Never fuel machine indoors because flammable vapors will accumulate in the area.
9. Never remove gas cap or add fuel while the engine is hot or running. Allow engine to cool at least two minutes before refueling.
10. Never over fill fuel tank. Fill tank to no more than ½ inch below bottom of filler neck to provide space for fuel expansion.
11. Replace gasoline cap and tighten securely.
12. If gasoline is spilled, wipe it off the engine and equipment. Move unit to another area. Wait 5 minutes before starting the engine.
13. Never store the machine or fuel container inside where there is an open flame, spark or pilot light as on a water heater, space heater, furnace, clothes dryer or other gas appliances.
14. To reduce fire hazard, keep mower free of grass, leaves, or other debris build-up. Clean up oil or fuel spillage and remove any fuel soaked debris.
15. Allow a mower to cool at least 5 minutes before storing.

General Service:

1. Never run an engine indoors or in a poorly ventilated area. Engine exhaust contains carbon monoxide, an odorless and deadly gas.
2. Before cleaning, repairing, or inspecting, make certain the blade and all moving parts have stopped. Disconnect the spark plug wire and ground against the engine to prevent unintended starting.
3. Check the blade and engine mounting bolts at frequent intervals for proper tightness. Also, visually inspect blade for damage (e.g., bent, cracked, worn) Replace blade with the original equipment manufacture’s (O.E.M.) blade only, listed in this manual. “Use of parts which do not

meet the original equipment specifications may lead to improper performance and compromise safety!”

4. Mower blades are sharp and can cut. Wrap the blade or wear gloves, and use extra caution when servicing them.
5. Keep all nuts, bolts, and screws tight to be sure the equipment is in safe working condition.
6. Never tamper with safety devices. Check their proper operation regularly.
7. After striking a foreign object, stop the engine, disconnect the spark plug wire and ground against the engine. Thoroughly inspect the mower for any damage. Repair the damage before starting and operating the mower.
8. Never attempt to make a wheel or cutting height adjustment while the engine is running.
9. Grass catcher components, discharge cover, and trail shield are subject to wear and damage which could expose moving parts or allow objects to be thrown. For safety protection, frequently check components and replace with original equipment manufacturer’s (O.E.M.) parts only, listed in this manual. Use of parts which do not meet the original equipment specifications may lead to improper performance and compromise safety.
10. Do not change the engine governor setting or overspeed the engine. The governor controls the maximum safe operating speed of the engine.
11. Maintain or replace safety and instruction labels, as necessary.
12. Observe proper disposal laws and regulations. Improper disposal of fluids and materials can harm the environment.

Your Responsibility

- Restrict the use of this power machine to persons who read, understand and follow the warnings and instructions in this manual and on the machine.



SECTION 2: SLOPE GAUGE

USE THIS PAGE AS A GUIDE TO DETERMINE SLOPES WHERE YOU MAY NOT OPERATE SAFELY.

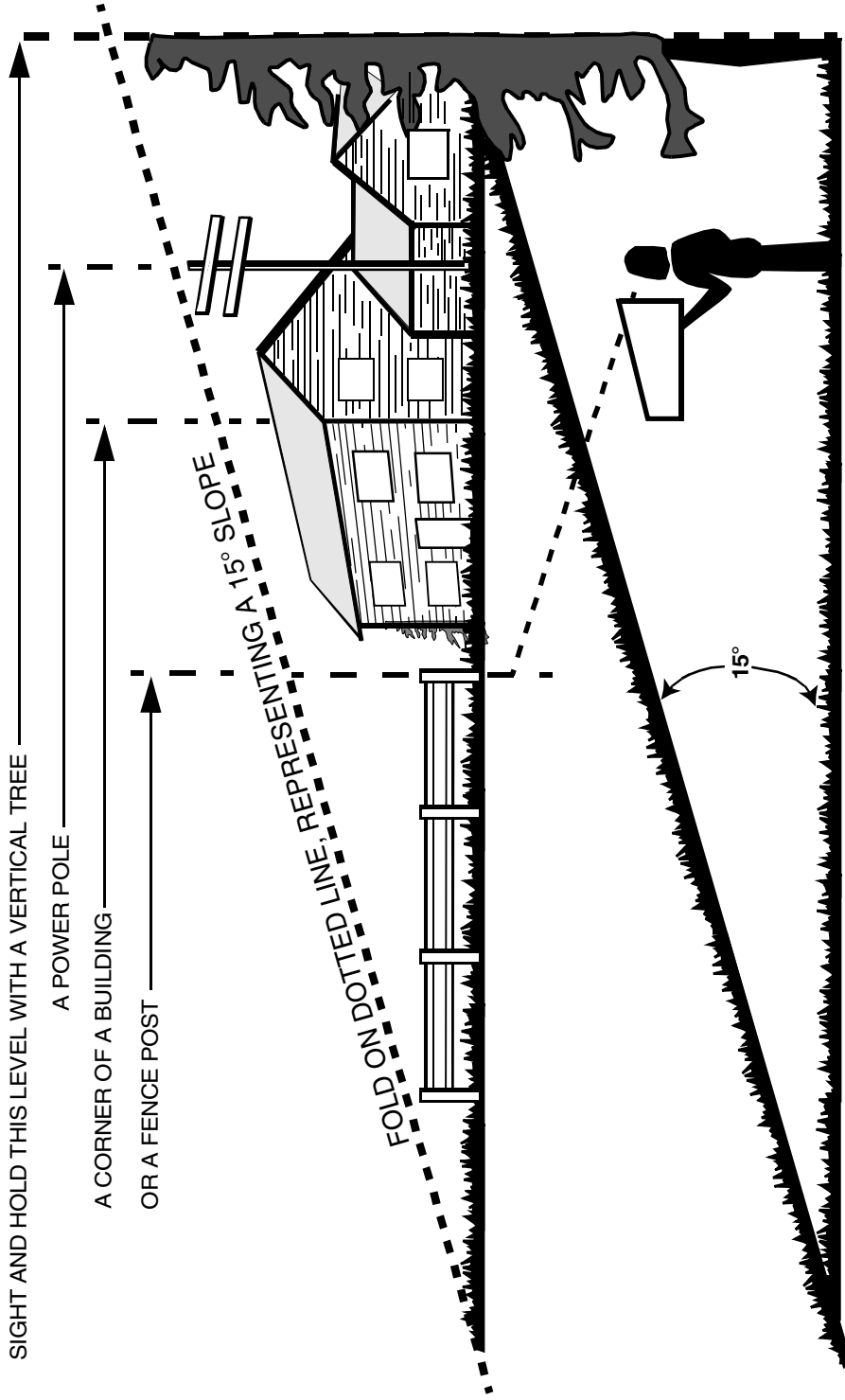

WARNING

Do not mow on inclines with a slope in excess of 15 degrees (a rise of approximately 2-1/2 feet every 10 feet). A riding mower could overturn and cause serious injury. If operating a walk-behind mower on such a slope, it is extremely difficult to maintain your footing and you could slip, resulting in serious injury. Operate RIDING mowers up and down slopes, never across the face of slopes. Operate WALK-BEHIND mowers across the face of slopes, never up and down slopes.

SECTION 3: ASSEMBLING YOUR LAWN MOWER

To Remove Unit From Carton

- Remove staples, break glue on top flaps, or cut tape at carton end and peel along top flap to open carton.
- Remove loose parts included with your unit (i.e., operator's manual, etc.).
- Cut along corners and lay carton down flat. Remove packing material.
- Roll or slide unit out of carton.

IMPORTANT: This unit is shipped without gasoline. Make sure to service engine with gasoline and oil as instructed in the separate engine manual before operating your mower.

NOTE: Reference to right or left side of the mower is observed from the operating position.

Tools Required

Pair of pliers (not necessary, but helpful)

Disconnect Spark Plug Wire

- Disconnect spark plug wire from the spark plug and attach rubber boot to a bolt on the engine to ground. See Figure 1.

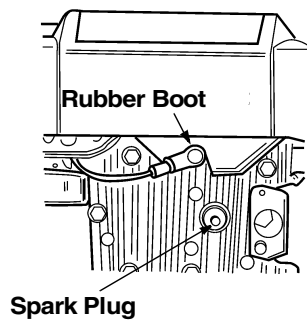
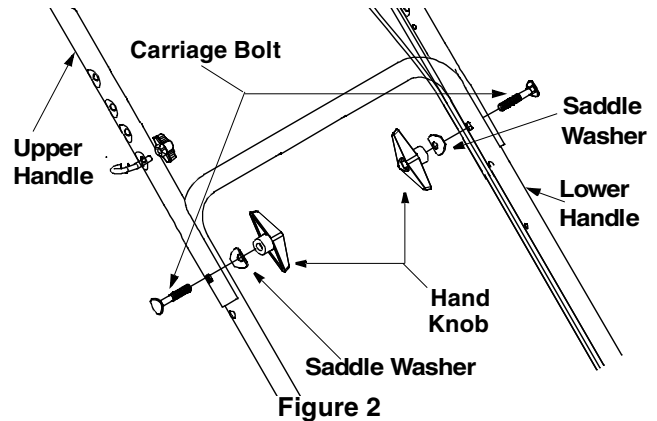

Figure 1

Attaching Handle

- Pull up and back on the upper handle to raise the handle into the operating position. Make certain the lower handle is seated securely into the handle mounting brackets. Tighten the hand knobs on each side of the handle (carriage bolts and saddle washers must be seated properly into the handle as shown). See Figure 2.

NOTE: Your mower is shipped with the handle in the higher height position. If you wish to lower the height of the handle, refer to the instructions for handle height adjustment on page 10.



- Remove the hairpin clips from the outer holes in the weld pins on the handle mounting brackets.
- Using a pair of pliers, squeeze one leg of the lower handle against the handle mounting bracket. Insert the hairpin clip into the inner hole on the weld pin. See Figure 3. Repeat on other side.

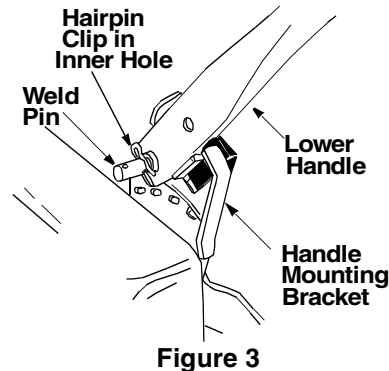

Attaching Starter Rope

- The rope guide is attached to the right side of the upper handle. Loosen the wing nut which secures the rope guide. For location of the wing nut, see Figure 4.

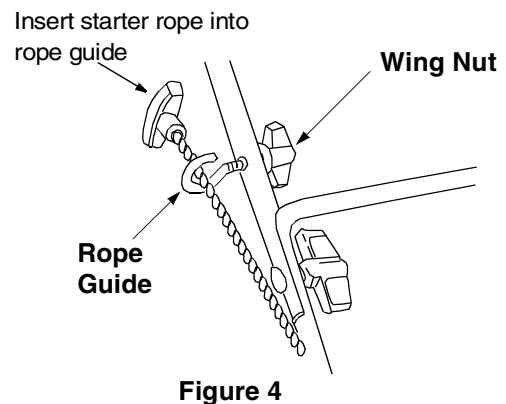

- With the spark plug wire disconnected and grounded, hold the blade control handle against the

upper handle, and pull the starter rope out of the engine. Release the blade control handle. Slip the starter rope into the rope guide. Tighten the wing nut. See Figure 4.

- Make certain all nuts and bolts are tightened securely.
- Attach cables to the lower handle with the two cable ties already on the lower handle, insert pegs on cable ties into the holes on the lower handle. Pull cable ties tight and cut off the extra. See Figure 5.

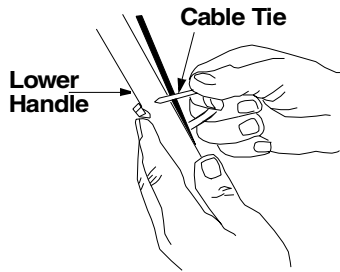

Figure 5

Converting to Side Discharge

- Your mower has been shipped as a mulcher. To convert it to a side-discharge mower, lift the mulching plug. Slide the two hooks on the side-discharge chute under the hinge pin on the mulching plug assembly. Lower the mulching plug. See Figure 6.

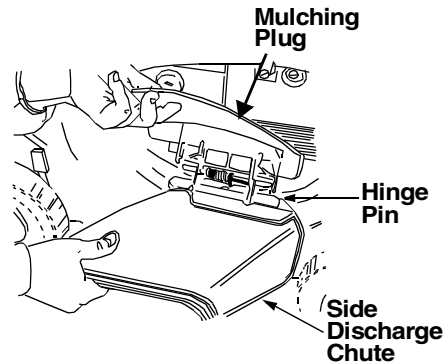

Figure 6

SECTION 4: KNOW YOUR LAWN MOWER

Compare Figure 7 with your equipment to get familiar with the mower controls before operating it.

Blade Control Handle

The blade control handle is located on the upper handle of the mower. The blade control handle must be depressed in order to operate the unit. Release the blade control handle to stop the engine and blade.



WARNING: This control mechanism is a safety device. Never attempt to bypass its operations. The blade will be rotating whenever the engine is running.

Throttle Control

Your engine is equipped with a constant speed throttle, which is set at full throttle for best performance.

Starter Rope

The starter rope is attached to the handle. Stand behind the unit and pull the starter rope to start the unit.

Primer

The primer is used to pump gas into the carburetor. Use it to start a cold engine, but do not use it to restart a warm engine after a short shutdown.

Mulching Plug

The mulching plug is used only for mulching purposes. This process recirculates the clippings back to the lawn. Do not operate the mower if the mulching plug is not firmly situated on the unit.

Cutting Height Adjustment Lever

This lever, located at each wheel, lets you adjust cutting height of the grass. Remember to put all four levers at the same height position to avoid uneven cut.

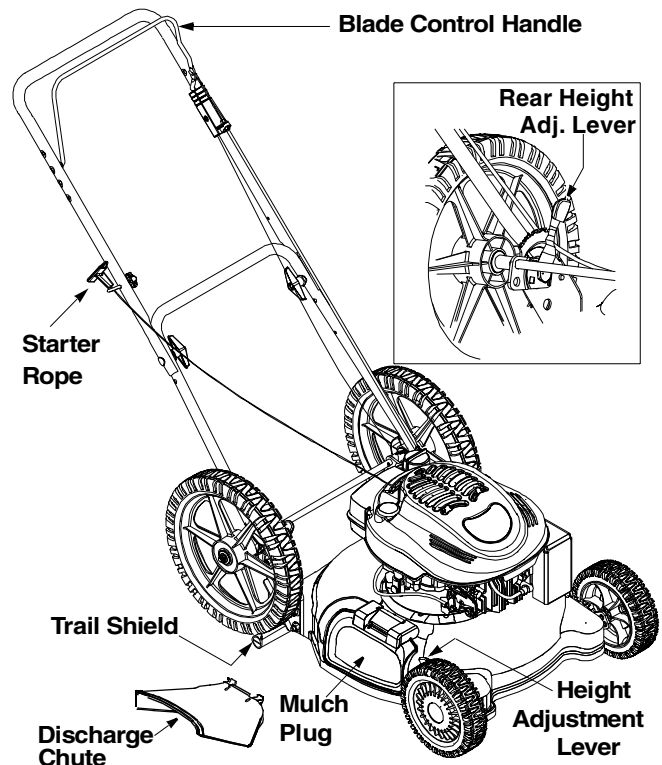

Figure 7

SECTION 5: OPERATING YOUR LAWN MOWER



WARNING: Keep hands and feet away from the chute area on cutting deck. The blade will be rotating whenever the engine is running.

WARNING: Be sure no one other than the operator is standing near the lawn mower while starting the engine or operating the mower.

WARNING: Never run engine indoors or in enclosed, poorly ventilated areas. Engine exhaust contains carbon monoxide, an odorless and deadly gas.

Gas and Oil Fill-Up

- Service the mower engine with gasoline and oil following instructions in the engine manual. If your mower was shipped with oil in the engine, fill up the required amount of gasoline only. Always make sure there is adequate oil in the engine before starting the engine. Fill up as necessary.



WARNING: Never fill fuel tank indoors, with engine running or until the engine has been allowed to cool for at least two minutes after running.

Adjusting Cutting Height

- Your mower was shipped at the lowest cutting height. For best results in mowing, keep the cutting height position high until it is determined which height is best for your lawn.
- Refer to height adjustments section of this manual on page 10 for instruction on how to adjust the cutting height and the handle height.

Before Starting

- Attach spark plug wire to spark plug. Make certain the metal cap on the end of the spark plug wire (inside the rubber boot) is fastened securely over the metal tip on the spark plug.

To Start Engine and Engage Blade

- Prime engine as instructed in the engine manual.
- Standing behind the unit, depress the blade control handle and hold it against the upper handle.

- Grasp starter handle and pull rope out slowly until engine reaches start of compression cycle (rope will pull slightly harder at this point). Let the rope rewind slowly.
- Pull rope with a rapid, continuous, full arm stroke. Keep a firm grip on starter handle. Return it slowly to the rope guide. If you encounter any problems, refer to the Trouble Shooting Guide for helpful information.

Stopping Engine and Blade

- Release the blade control handle to stop the engine and the blade.



WARNING: The blade continues to rotate for a few seconds after the engine is shut off. Do not touch the blade in any way while it is still rotating.

- Disconnect spark plug wire and ground it against the engine to prevent accidental starting while equipment is unattended.

Using Your Rotary Mower

- Be sure that lawn is clear of stones, sticks, wire, or other objects which could damage lawn mower or engine. Such objects could be accidentally thrown by the mower in any direction and cause serious personal injury to the operator and others.
- For best results, do not cut wet grass because it tends to stick to the underside of the mower, preventing proper discharge of grass clippings, and could cause you to slip and fall. New grass, thick grass or wet grass may require a narrower cut. Speed of the mower should be adjusted to the condition of the lawn.
- For a healthier lawn, always cut off one-third or less of the total length of grass. Lawn should be mowed in the fall season as long as there is growth.



WARNING: If you strike a foreign object, stop the engine. Remove wire from spark plug, thoroughly inspect the mower for any damage, and repair the damage before restarting and operating the mower. Extensive vibration of the mower during operation is an indication of damage. The unit should be promptly inspected and repaired

SECTION 6: MAKING ADJUSTMENTS



WARNING: Do not at any time make any adjustment to your lawn mower without first stopping the engine and disconnecting the spark plug wire.

Handle Height

Your mower is shipped with the handle in the higher height position. To lower the handle height for your convenience, proceed as follows.

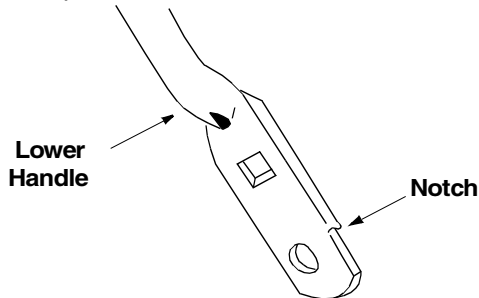

Figure 8

- Remove the starter rope from the rope guide.
- Remove the upper handle by removing the hand knobs and carriage bolts. Lay the upper handle out of the way, being careful not to bend or kink cables.
- Remove the hairpin clips from the weld pins on the handle brackets. Press outward on the legs of the lower handle, and remove it from the mower.
- Turn the lower handle around so the notches on the bottom of the lower handle are facing forward as shown in Figure 8. Reassemble, placing the bottom holes in the handle over the weld pins in the handle mounting bracket.
- Reassemble the upper handle.
- Place the hairpin clips in the inner holes in the weld pins. Reattach the starter rope.

Carburetor

Minor carburetor adjustments may be required to compensate for differences in fuel, temperature, altitude and load. To adjust carburetor, refer to the engine manual.

NOTE: A dirty air cleaner will cause an engine to run rough. Make sure air cleaner is clean and attached to the carburetor before adjusting carburetor.



WARNING: If any adjustments are made to the engine while the engine is running (e.g. carburetor), keep clear of all moving parts and heated surfaces (e.g. muffler).

Cutting Height

An adjusting plate and thumb lever at each wheel position provides cutting height adjustment. Each adjusting plate has nine height positions. Height of cut will be changed when the thumb lever is moved from one hole to another.

- Simply depress the lever towards wheel and move wheel and lever assembly to desired position. All wheels must be placed in the same relative position. See Figure 9.

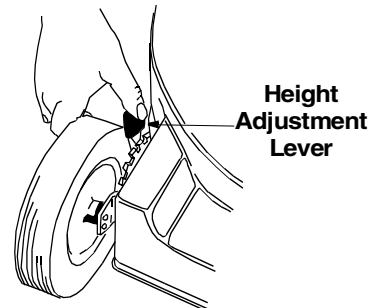

Figure 9

SECTION 7: MAINTAINING YOUR LAWN MOWER



WARNING: Always stop engine and disconnect spark plug wire before cleaning, lubricating or doing any kind of maintenance work on lawn mower.

Lubrication

Blade Control

- Lubricate the pivot points on the blade control handle and the brake cable at least once a season

with light oil. See Figure 10. The blade control must operate freely in both directions.

Wheels

- Lubricate the wheel bearings (if so equipped) at least once a season with light oil (or engine oil). Also, if the wheels are removed for any reason, lubricate the surface of the axle bolt and the inner surface of the wheel with light oil. See Figure 10.

Engine

- Follow engine manual for lubrication instructions.

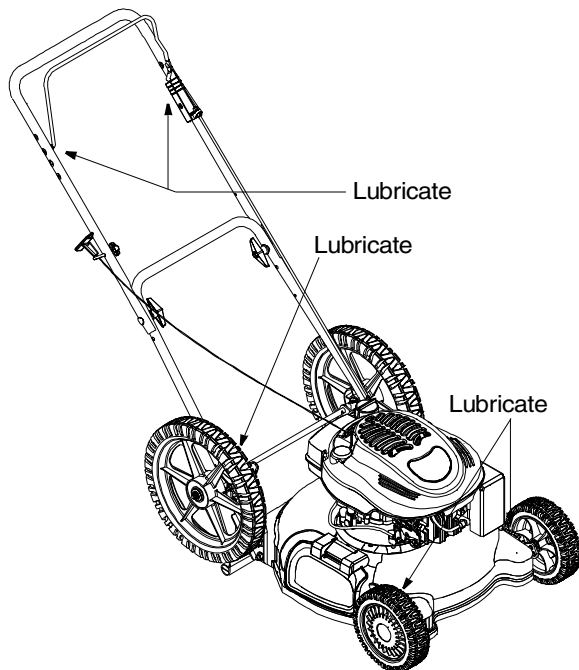

Figure 10

NOTE: When tipping the unit, empty fuel tank and keep engine spark plug side up.

Cutting Blade



WARNING: When removing the cutting blade for sharpening or replacement, protect hands by using heavy gloves or a rag to grasp the cutting blade.

To remove blade:

- Remove the bolt and blade bell support which hold the blade and adapter to the engine crankshaft. See Figure 11. Remove the blade and the adapter from the crankshaft.



WARNING: Periodically inspect the blade adapter for cracks, especially if you strike a foreign object. Replace when necessary.

- When sharpening the blade, follow the original angle of grind as a guide. It is extremely important that each cutting edge receives an equal amount of grinding to prevent an unbalanced blade. An unbalanced blade will cause excessive vibration when rotating at high speeds, may damage the mower and/or cause personal injury.
- The blade can be tested by balancing it on a round shaft screwdriver. Remove metal from the heavy side until it balances evenly. It is recommended that the blade always be removed from the adapter for the best test of balance.

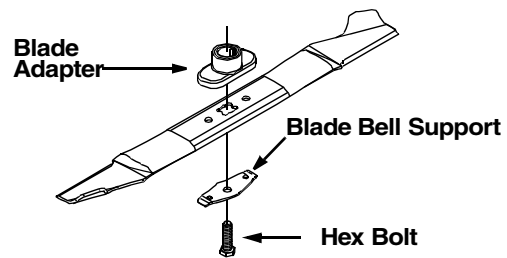

Figure 11

- Before reinstalling the blade and the blade adapter to the unit, lubricate the engine crankshaft and the inner surface of the blade adapter with light oil (or engine oil). Also lubricate the bolt holes and bolts.

To Reinstall Blade:

- Be sure to install the blade with the side of the blade marked "Bottom" (or with part number) facing the ground when the mower is in the operating position.
- Make sure the blade is aligned with and seated onto the blade adapter flanges.
- Place blade bell support on blade. Make sure the notches on the blade bell support are aligned with the small holes in the blade. See Figure 11.
- Replace hex bolt. Tighten to recommended torque.

Blade Torque: 450 in. lbs. min., 600 in. lbs. max.

- To ensure safe operation of mower, check all nuts and bolts periodically for correct torque.

Cutting Deck

- The underside of the mower deck should be cleaned after each use to prevent a build-up of grass clippings, leaves, dirt or other matter. If this debris is allowed to accumulate, it will invite rust and corrosion, and may prevent proper mulching.
- The deck may be cleaned by tilting the mower and scraping clean with a suitable tool (make certain the spark plug wire is disconnected).

NOTE: We do not recommend the use of pressure washers or garden hose to clean your unit. They may cause damage to electric components, spindles, pulleys, bearings or the engine. The use of water will shorten life and reduce serviceability.

Engine

- Refer to the engine manual for all engine maintenance instructions.
- Maintain engine oil as instructed in the engine manual.
- Service air cleaner every 25 hours of operation under normal conditions. Clean every few hours under extremely dusty conditions. Poor engine

performance and flooding usually indicates that the air cleaner should be serviced. To service the air cleaner, refer to the engine manual.

- The spark plug should be cleaned and the gap reset once a season. Spark plug replacement is recommended at the start of each mowing season; check engine manual for correct plug type and gap specifications.

- Clean engine regularly with a cloth or brush. Keep the cooling system (blower housing area) cleaned to permit proper air circulation which is essential to engine performance and life. Make sure to remove all grass, dirt and combustible debris from muffler area.

SECTION 8: OFF-SEASON STORAGE

The following steps should be taken to prepare lawn mower for storage.

- Clean and lubricate mower thoroughly as described in the lubrication instructions.

NOTE: *We do not recommend the use of pressure washers or garden hose to clean your unit. They may cause damage to electric components, spindles, pulleys, bearings or the engine. The use of water will result in shortened life and reduce serviceability.*

- Refer to engine manual for correct engine storage instructions.
- Coat mower's cutting blade with chassis grease to prevent rusting.
- Store mower in a dry, clean area. Do not store next to corrosive materials, such as fertilizer.

NOTE: *When storing any type of power equipment in an unventilated or metal storage shed, care should be taken to rust-proof the equipment. Using a light oil or silicone, coat the lawn mower, especially cables and all moving parts, before storing it for the off-season.*

SECTION 9: TROUBLE SHOOTING GUIDE

Trouble	Possible Cause(s)	Corrective Action
Engine fails to start	<ol style="list-style-type: none"> 1. Blade control handle disengaged. 2. Spark plug wire disconnected. 3. Fuel tank empty, or stale fuel. 4. Blocked fuel line. 5. Faulty spark plug. 6. Engine flooded. 	<ol style="list-style-type: none"> 1. Engage blade control handle. 2. Connect wire to spark plug. 3. Fill tank with clean, fresh gasoline. 4. Clean fuel line. 5. Clean, adjust gap or replace. 6. Wait a few minutes to restart. Do not prime.
Engine runs erratic	<ol style="list-style-type: none"> 1. Spark plug wire loose. 2. Blocked fuel line or stale fuel. 3. Vent in gas cap plugged. 4. Water or dirt in fuel system. 5. Dirty air cleaner. 6. Carburetor out of adjustment. 	<ol style="list-style-type: none"> 1. Connect and tighten spark plug wire. 2. Clean fuel line; fill tank with fresh gasoline. 3. Clear vent. 4. Drain fuel tank. Refill with fresh fuel. 5. Clean air cleaner. 6. Adjust carburetor.
Engine overheats	<ol style="list-style-type: none"> 1. Engine oil level low. 2. Air flow restricted. 3. Carburetor not adjusted properly. 	<ol style="list-style-type: none"> 1. Fill crankcase with proper oil. 2. Remove blower housing and clean. 3. Adjust carburetor.
Occasional skip (hesitates) at high speed	<ol style="list-style-type: none"> 1. Spark plug gap too close. 	<ol style="list-style-type: none"> 1. Adjust gap to .030".
Idles poorly	<ol style="list-style-type: none"> 1. Spark plug fouled, faulty or gap too wide. 2. Carburetor improperly adjusted. 3. Dirty air cleaner. 	<ol style="list-style-type: none"> 1. Reset gap to .030" or replace spark plug. 2. Adjust carburetor. 3. Clean air cleaner.
Excessive vibration	<ol style="list-style-type: none"> 1. Cutting blade loose or unbalanced. 2. Bent cutting blade. 	<ol style="list-style-type: none"> 1. Tighten blade and adapter. Balance blade. 2. Replace blade.
Mower will not mulch grass	<ol style="list-style-type: none"> 1. Wet grass. 2. Excessively high grass. 3. Dull blade. 	<ol style="list-style-type: none"> 1. Wait until later to cut. 2. Mow once at a high cutting height, then mow again at desired height or make a narrower cutting swath (1/2 width). 3. Sharpen or replace blade.
Uneven cut	<ol style="list-style-type: none"> 1. Wheels not positioned correctly. 2. Dull blade. 	<ol style="list-style-type: none"> 1. Place all four wheels in same height position. 2. Sharpen or replace blade.

SECTION 10: PARTS LIST FOR MODEL 573

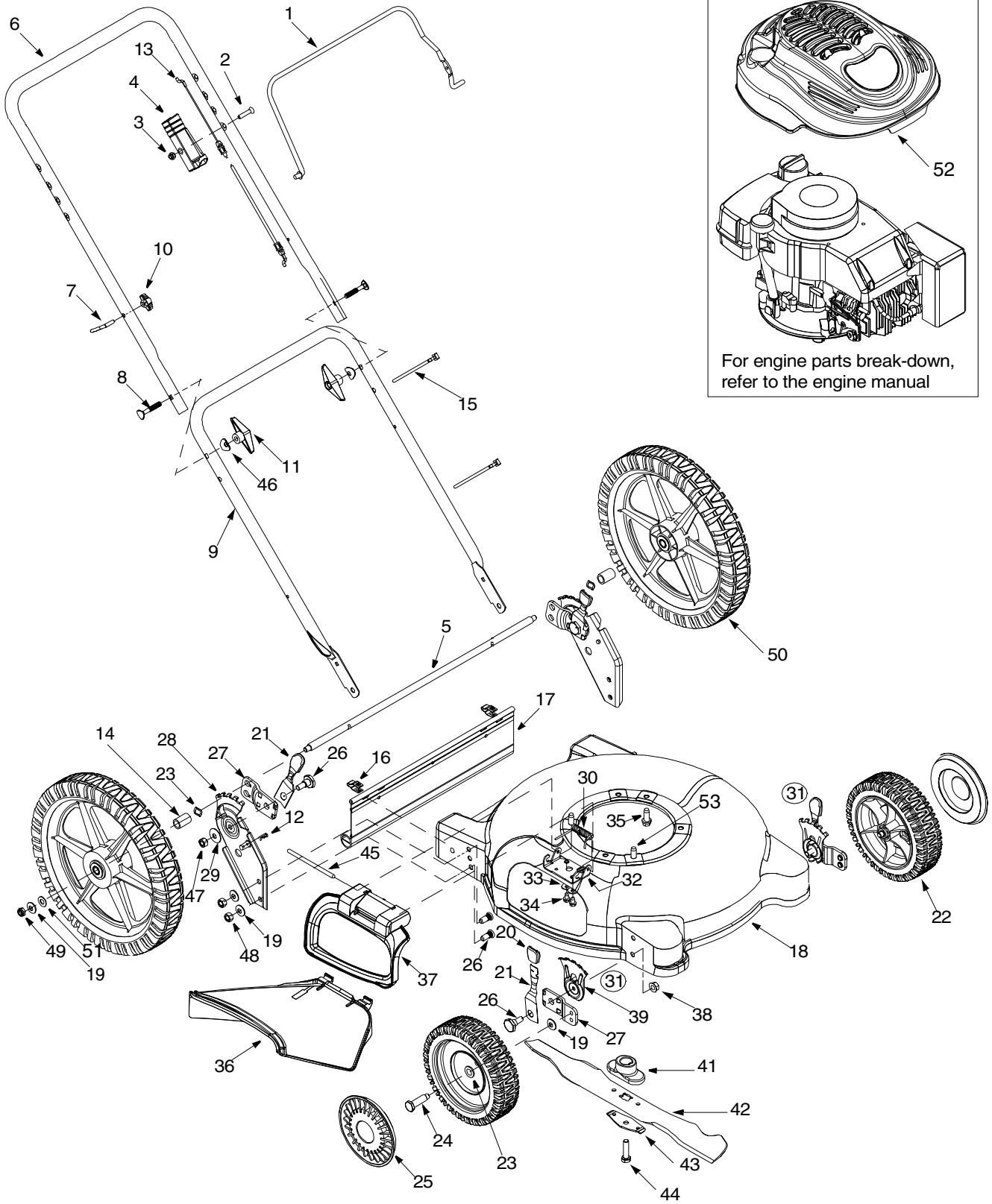

Model 573

Ref. No.	Part No.	Description	Ref. No.	Part No.	Description
1.	747-0824	Control Handle		682-0517	Handle Bracket Assembly LH
2.	710-1270	Oval C-Sunk Screw	29.	736-0331	Bell Washer
3.	712-0324	Hex Lock Nut	30.	732-0731	Torsion Spring
4.	746-0883	Control Housing	31.	14578	Height Adjust. Assembly RH
5.	738-0878	Rear Axle		14579	Height Adjust. Assembly LH*
6.	749-0705A	Upper Handle	32.	782-7006	Mounting Bracket
7.	710-1205	Rope Guide	33.	736-0270	Bell Washer
8.	710-1174	Carriage Bolt	34.	710-0599	Hex Washer Hd. TT Screw
9.	749-0928A	Lower Handle	35.	710-0654A	TT Sems Screw
10.	720-0279	Wing Nut	36.	731-1409	Chute Deflector
11.	720-0284	Hand Knob	37.	682-7002	Mulching Plug Assembly
12.	714-0104	Hairpin Clip	38.	712-0431	Hex Lock Nut
13.	746-0555	Control Cable 55"	39.	15261A	Height Adjustment Plate
14.	750-0151	Spacer	41.	748-0376C	Blade Adapter
15.	726-0240	Cable Tie		753-0588	Blade Adapter Kit (for service)
16.	17098	Hinge Clip	42.	742-0740	20" Mulching Blade
17.	731-0872A	Trail Shield	43.	736-0524A	Blade Bell Support
18.	682-0139	Cutting Deck Assembly: 20"	44.	710-1044	Hex Bolt
19.	736-0105	Bell Washer	45.	747-0710	Hinge Pin
20.	720-0426	Knob: Height Adjustment	46.	736-0451	Saddle Washer
21.	732-0404	Lever: Spring	47.	712-0798	Lock Nut
22.	734-2005A	Front Wheel Assy. 8 x 2.125"	48.	712-0328	Hex Nut 3/8-24
23.	736-0504	Wave Washer	49.	712-3020	Lock Nut
24.	738-0102	Axle Bolt: Front	50.	734-2043	Rear Wheel 14 x 2.125"
25.	731-1426	Hubcap: Radial Spoke, Yellow	51.	736-3050	Flat Washer
26.	738-0507B	Shoulder Bolt	52.	731-04123	Engine Shroud
27.	15262B	Pivot Bar	53.	738-04032	Hex Bolt #10-32 x 0.30"
28.	682-0518	Handle Bracket Assembly RH			

NOTE: For **painted parts**, please refer to the list of color codes below. Please add the applicable color code, wherever needed, to the part number to order a replacement part. For instance, if a part numbered 700-xxxx is painted Yard-Man Green, the part number to order would be 700-xxxx-0665.

Yard-Man Green: 0665

Yard-Man Yellow: 0674

Powder Black: 0637

MANUFACTURER'S LIMITED WARRANTY FOR:



The limited warranty set forth below is given by MTD LLC with respect to new merchandise purchased and used in the United States, its possessions and territories.

MTD LLC warrants this product against defects for a period of two (2) years commencing on the date of original purchase and will, at its option, repair or replace, free of charge, any part found to be defective in materials or workmanship. This limited warranty shall only apply if this product has been operated and maintained in accordance with the Operator's Manual furnished with the product, and has not been subject to misuse, abuse, commercial use, neglect, accident, improper maintenance, alteration, vandalism, theft, fire, water, or damage because of other peril or natural disaster. Damage resulting from the installation or use of any accessory or attachment not approved by MTD LLC for use with the product(s) covered by this manual will void your warranty as to any resulting damage.

Normal wear parts or components thereof are subject to separate terms as follows: All normal wear parts or component failures will be covered on the product for a period of 90 days regardless of cause. After 90 days, but within the two year period, normal wear part failures will be covered ONLY IF caused by defects in materials or workmanship of OTHER component parts. Normal wear parts and components include, but are not limited to: batteries, belts, blades, blade adapters, grass bags, rider deck wheels, seats, snow thrower skid shoes, shave plates, auger spiral rubber, and tires.

HOW TO OBTAIN SERVICE: Warranty service is available, WITH PROOF OF PURCHASE, through your local authorized service dealer. To locate the dealer in your area, check your Yellow Pages, or contact MTD LLC at P.O. Box 361131, Cleveland, Ohio 44136-0019, or call 1-800-800-7310 or log on to our Web site at www.mtdproducts.com.

This limited warranty does not provide coverage in the following cases:

- a. The engine or component parts thereof. These items carry a separate manufacturer's warranty. Refer to applicable manufacturer's warranty for terms and conditions.
- b. Log splitter pumps, valves, and cylinders have a separate one year warranty.
- c. Routine maintenance items such as lubricants, filters, blade sharpening, tune-ups, brake adjustments, clutch adjustments, deck

adjustments, and normal deterioration of the exterior finish due to use or exposure.

- d. MTD LLC does not extend any warranty for products sold or exported outside of the United States, its possessions and territories, except those sold through MTD LLC's authorized channels of export distribution.
- e. Parts that are not genuine MTD parts are not covered by this warranty.
- f. Service completed by someone other than an authorized service dealer is not covered by this warranty.
- g. Transportation charges and service calls are not covered.

No implied warranty, including any implied warranty of merchantability of fitness for a particular purpose, applies after the applicable period of express written warranty above as to the parts as identified. No other express warranty, whether written or oral, except as mentioned above, given by any person or entity, including a dealer or retailer, with respect to any product, shall bind MTD LLC. During the period of the warranty, the exclusive remedy is repair or replacement of the product as set forth above.

The provisions as set forth in this warranty provide the sole and exclusive remedy arising from the sale. MTD LLC shall not be liable for incidental or consequential loss or damage including, without limitation, expenses incurred for substitute or replacement lawn care services or for rental expenses to temporarily replace a warranted product.

Some states do not allow the exclusion or limitation of incidental or consequential damages, or limitations on how long an implied warranty lasts, so the above exclusions or limitations may not apply to you.

In no event shall recovery of any kind be greater than the amount of the purchase price of the product sold.

Alteration of safety features of the product shall void this warranty. You assume the risk and liability for loss, damage, or injury to you and your property and/or to others and their property arising out of the misuse or inability to use the product.

This limited warranty shall not extend to anyone other than the original purchaser or to the person for whom it was purchased as a gift.

HOW STATE LAW RELATES TO THIS WARRANTY: This limited warranty gives you specific legal rights, and you may also have other rights which vary from state to state.